

In-house development

Own manufacturing

Sole distributor in Germany

Working with distributors worldwide

TAS
SCHÄFER



External
Clamping devices

Overview



3073 Mini-Range

For very low torque transmission
Very small profile
Very light weight

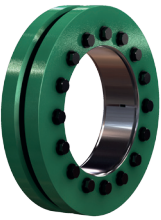

3051 Light-Range

For low torque transmission
Small profile
Lightweight



3071 Standard-Range

For Medium torque transmission
Average profile
Average weight



3081 Standard-Range strengthened

Like 3071, but with screws class 12.9
For higher quality shaft and hub materials
Higher transmissible torque than 3071



3091 Heavy-Range

For high torque transmission
Heavy duty construction



3093 Heavy-Range strengthened

Like 3091, but with screws class 12.9
For very high transmissible torque
Heavy duty construction



Type 52

Suitable for Stiebel - helical-bevel gears
With bolt protection against contact (guard)

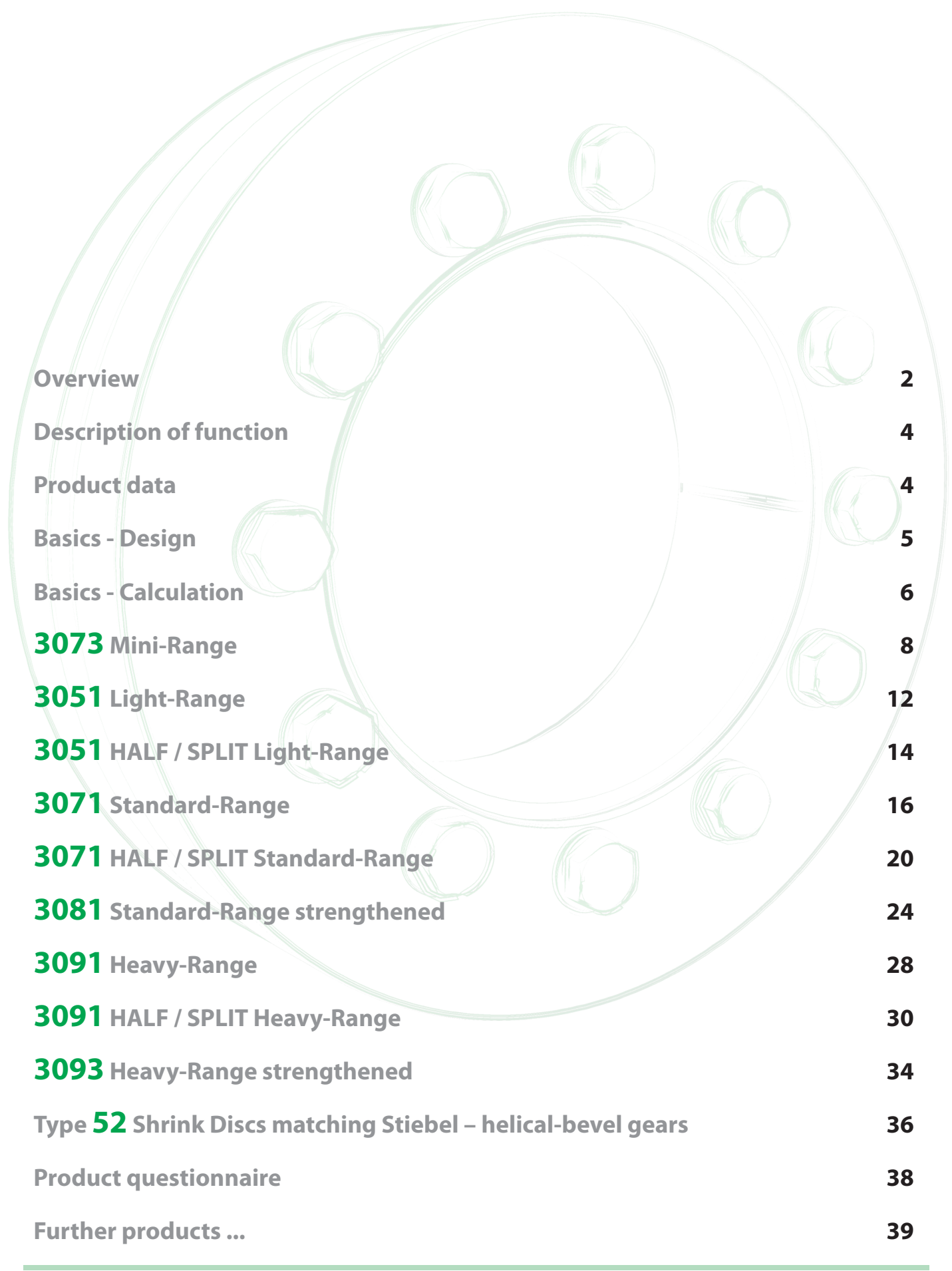

Overview	2
Description of function	4
Product data	4
Basics - Design	5
Basics - Calculation	6
3073 Mini-Range	8
3051 Light-Range	12
3051 HALF / SPLIT Light-Range	14
3071 Standard-Range	16
3071 HALF / SPLIT Standard-Range	20
3081 Standard-Range strengthened	24
3091 Heavy-Range	28
3091 HALF / SPLIT Heavy-Range	30
3093 Heavy-Range strengthened	34
Type 52 Shrink Discs matching Stiebel – helical-bevel gears	36
Product questionnaire	38
Further products ...	39

Description of function

Three part shrink disc of the types TAS 30.. & TAS 52..

The main function of a shrink disc is the safe connection of a shaft with a hub by means of friction. For example, between a drive shaft and a transmission hollow shaft. The shrink disc generates a backlash-free connection by pressing the hub onto the shaft. This connection is mainly used to transmit torque.

The shrink disc only provides the required forces, and transfers no forces or moments between shaft and hub by itself. Therefore, the force flow does not pass through it.

It is installed by sliding the shrink disc onto the hollow shaft and the subsequent tightening of the screws. By using conical surfaces the inner diameter reduces and the radial pressure is built up. The 30xx range of shrink discs are not self-locking. The clamping forces are provided and controlled through the screws.

This allows the direct compensation of the clearance between the shaft and hub, without an overload that may occur on path controlled shrink discs, due to small or over sized clearance.

The supplied shrink discs are ready for installation.

To achieve proper operation with a sufficiently high coefficient of friction, the contact surfaces between shaft and hub must be dry, clean and free of grease. The functional surfaces of the shrink disc, the thread and head rests of the screws, are equipped at the factory with lubricant. The contact surfaces between the hub and shrink disc must be provided with grease before installation.

A detailed installation manual is available on the Internet.

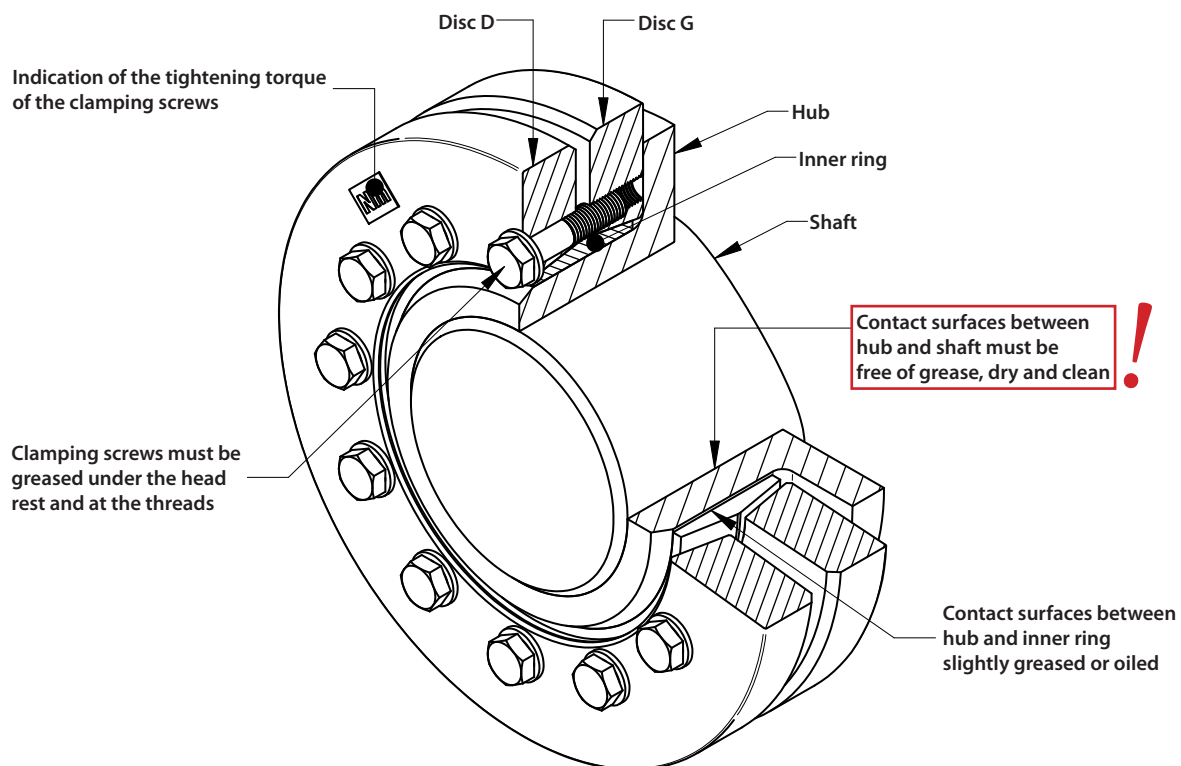

Product data

Data sheets

- Contact us if a data sheet for an individual product is required.

CAD data

- We provide CAD data for our products in various formats. These can be found online at www.traceparts.com. If the desired product is not available, please contact us directly.

Basics - Design

Clamping length for shrink discs

The clamping length l of the shrink disk at the junction l_K (between shaft and hub), should be chosen to be somewhat wider to minimize the stress concentration at this point. An excessively wide connection increases the tendency to fretting corrosion, because the pressure decreases outward. The pressure is distributed approximately at an angle between $15^\circ - 20^\circ$ through the hub. This is largely dependent on the hub wall thickness and stiffness of the shaft. A good approximation can be made from the following equation:

$$Clamping\ length\ of\ the\ contact\ area: \quad l_K = 0,316(d - d_w) + l$$

The cylindrical surfaces should be located symmetrically under the shrink disc! With a slightly different clamping length the transmissible torque M will not change, because a smaller contact surface results in a higher pressure - ergo a larger contact surface causes lower pressure.

Tightening torque of the clamping screws

The given tightening torque values in the tables for the screws are based on a friction coefficient $\mu_{ges} = 0,1$. In principle, the specified tightening torque M_A can be reduced to M_{Agew} to reduce stresses in the components. This may be necessary for soft materials and bored shafts. The reduction of M_A also reduced the pressure p_N and transmissible torque M . The ratio is approximately proportional and can be calculated according to:

$$M_{gew} = \frac{M_{Agew}}{M_A} M \quad \text{also} \quad p_{Ngew} = \frac{M_{Agew}}{M_A} p_N$$

The tightening torques can not be reduced arbitrary, therefore apply the following limits:

$$M_{Agew} \geq \begin{pmatrix} \text{Class 8.8 : } 0,85 M_A \\ \text{Class 10.9 : } 0,70 M_A \\ \text{Class 12.9 : } 0,60 M_A \end{pmatrix} \leq M_A$$

A further reduction requires additional screw locks!

Tolerances and surfaces

The values found in the product data based on surface quality and tolerances according to the table below. These values are given as recommendations.

Higher values for the surface roughness reduces the transmissible torque and promote unwanted settling. Larger clearance also reduces the transmissible torque and heightened tensions in the hub.

In the case of significantly different values, please contact us!

Recommended tolerances and surface roughness				
>	≤	FS _{max} mm	Clearance Hub/Shaft	Rz µm
9	18	0,022	H6/h6	10
18	30	0,026	H6/h6	10
30	50	0,032	H6/h6	10
50	80	0,049	H7/h6	10
80	120	0,057	H7/h6	16
120	150	0,065	H7/h6	16
150	180	0,079	H7/g6	16
180	250	0,090	H7/g6	16
250	315	0,101	H7/g6	16
315	400	0,111	H7/g6	16
400	500	0,123	H7/g6	25
500	630	0,136	H7/g6	25
630	800	0,154	H7/g6	25
800	1000	0,172	H7/g6	25

Technical drawing showing a cross-section of a shrink disc assembly. The drawing includes a table of material and mechanical properties, and a list of technical specifications.

Alle Werte beziehen sich auf M_{Agew} !	All values refer to M_{Agew} !	Zeichnung ist unmaßstäblich!	Drawing is not to scale!
Elastizitätsmodul Nabe	E-modulus hub	$E_h = 210\,000\text{ N/mm}^2$	
Elastizitätsmodul Welle	E-modulus shaft	$E_w = 210\,000\text{ N/mm}^2$	
Reibwert Schraube	Friction coefficient screw	$\mu_s = 0,10$	
Reibwert Konus	Friction coefficient cone	$\mu_k = 0,05$	
Reibwert Nabe/Welle	Friction coefficient hub/shaft	$\mu_w = 0,15$	
Sicherheitsfaktor	Safety factor	SF = 1,1	
Max. übertragbares Drehmoment	Max. transmittable torque	$M_{t,max} = 81\,700\text{ Nm}$	
Max. Drehzahl	Max. RPM	$n_{max} = 1\,600\text{ min}^{-1}$	
Trägheitsmoment	Moment of inertia	$I = 0,7921875\text{ kgm}^2$	
Übermaß nach DIN 7190	Over-size acc. to DIN 7190	$U_{Wj} = 0,191\text{ mm}$	
Anpressdruck Nabe/Welle	Contact pressure hub/shaft	$P_W = 224\text{ N/mm}^2$	
Anpressdruck Schrumpfscheibe/Nabe	Contact pressure shrink disc/hub	$P_K = 252\text{ N/mm}^2$	

Additional parameters from the drawing:

- Material: DIN 931
- $M_{Amax} = 250\text{ Nm}$
- $M_{Agew} = 250\text{ Nm}$
- Tolerance_{min} = -7%
- $T_{WIN} = H7/g6$
- $S_{max} = 0,079$
- $S_{min} = 0,014$

Customer: Ch. Müller
 Drawing no: 3071-200
 Description: Schrumpfscheibe / Shrink disc
 Weight: 39 kg
 Version: 1.41 - 14.12.2011

Basics - Calculation

The calculation of the values, given in the catalogue, are based on the following assumptions and simplifications:

Transmissible torque

A shrink disc connection is capable of transmitting torque, bending moment and axial force. Alternatively, the transmissible torque M_{max} is specified in the product data. If such loads occur simultaneously then they must be added vectorially to the resultant moment M_{res} . The formula below applies to the resulting moment:

$$M_{res} \leq M_{max}$$

At different load cases, these are individually checked against M_{max} !

M_{res} is determined for combined loads as follows:

$$M_{res} = \sqrt{M_T^2 + M_B^2 + (F_{AX} \frac{d_W}{2})^2}$$

with $M_B \leq 0,3 M_T$ as the limit* for the the bending moment

*In principle, the maximum bending moment corresponds to the maximum transmittable torque. The limitation to $0,3 M_T$ is due to the change of the surface pressure at the edges of the connection. (see also „Bending moment“)

This results in the following relationships:

Torque only:

The maximum torque is equivalent to M_{max} .

Bending moment only:

The maximum bending moment corresponds to $0,3 M_T$.

Axial force only:

The maximum axial force is $M_{max} \frac{2}{d_W}$.

A different equation applies for very small shrink discs (3073):

$$M_B \leq 0,2 M_T$$

Depending on the application, additional safety factors need to be considered for the individual loads!

Calculation of transmissible torques and forces

The catalogue data relates to specific shaft diameters which we recommend using. If the shaft diameter is between two sizes, the larger shrink disc should be selected. A deviation is possible within certain limits but the predetermined tolerances and surface roughness should be considered.

The shaft diameter and transmissible torque behave approximately proportional to each other. The transmissible torque increases with greater shaft diameter and vice versa. In contrast, the transmissible axial force changes only slightly. This is not due to the shaft diameter but because of the change in stiffness of the hub when the inner diameter changes.

Within certain limits, the changes can be linearly approximated. Information about the range of the respective shaft diameter can be found in the product data.

The determination of the deviating values is explained below. Please contact us if the shaft diameter must be outside the indicated range.

The formula below calculates the torque for specific shaft diameters:

$$M = M_{max(Catalog)} \frac{d_{W(target)}}{d_{W(Catalog)}}$$

The corresponding axial force which is transmitted instead of the torque, results as follows:

$$F_{ax} = M \frac{2}{d_{W(table)}}$$

Radial force

Radial forces cause a change in pressure at the contact surface. In the force direction, the pressure increases on the one side and is reduced accordingly on the other side. This depends on the amount of radial force and the rigidity of the parts.

The following equation can be used to approximate the pressure change:

$$\Delta p_W = 0,75 \frac{F_{AX}}{d_W I_K}$$

The modified pressures $p_{Wmin,max}$ results from the following equation:

$$p_{Wmin,max} = p_W \pm \Delta p_W$$

The minimum pressure p_{Wmin} should be at least 50 N/mm² to avoid gap corrosion. In addition, the material must be designed for a maximum pressure p_{Wmax} .

Basics - Calculation

Bending moment

Here the situation is similar to the radial forces. However the pressure is greatest at the ends of the connection in this case. Again, the amount and stiffness are important. This leads to the following approximation:

$$\Delta p_w = 4,5 \frac{M_B}{d_w l_K^2}$$

As before, the modified pressures results from:

$$p_{wmin,max} = p_w \pm \Delta p_w$$

The conditions for minimum and maximum pressure are the same as before. It should be noted that there could be a change in pressure due to radial force!

Shaft and hub calculation

The catalogue contains information on the generated surface pressure for each shrink disc. The hub will be deformed due to the applied radial force. In addition to the clearance between shaft and hub, shaft stiffness and surface finish should be considered. For solid shafts the flexibility can be ignored, but with hollow shafts (see „Bore in the shaft (hollow shaft)“) there is greater deformation and thus greater stresses in the components. This must be considered in addition to other loads.

The stresses in the hub can be determined by various hypotheses, such as GEH. We will not make a presentation and analyse results at this point because we would only be able to cover a very limited range of static applications. Various calculation methods for different cases can be found in engineering literature or using specialised software. However, for complex geometry often only a calculation by FEM gives reliable results.

The information on the minimum yield strength of shafts and hubs are suggested recommendations, based on typical values for such applications. They are provided as guidelines and are not a replacement for a proper calculation for a given application!

Notch effect

Generally there is a notch effect on the components, caused by the radial pressure of the shrink disc. This depends mainly on the applied pressure. The notch effect is generally higher on the hub than on the shaft, because here the inner ring of the shrink disc is directly pressed onto the hub, while the stresses are distributed through the hub before reaching the shaft. The notch factors range from 2,5 to 3,5 for the hub and it is between 1,5 and 2 for the shaft. This can be mitigated by suitable design features, such as relief notches.

Some standards provide the possibility of a notch factor to be determined by a fit pairing for a shrink-connection. A similar method also can be used for a shrink disc connection. To this end an oversize can be calculated from the applied surface pressures. As a result, a matching fit pair can be determine and thus a resultant notch factor found.

Bore in the shaft (hollow shaft)

A large bore d_b in the shaft or the use of a hollow shaft, reduces the stiffness of this component against radial pressure. This leads to a decrease in pressure p_w , a reduced transmissible torque M , a contraction Δd_b within the shaft and an increase of stresses in these components. Basically, a bore should not be greater than $0,3 d_w$.

The screenshot displays the TAS SCHÄFER software interface, which includes a technical drawing of a shrink disc assembly and a detailed calculation table. The drawing shows a shaft with diameter $d_w = 200$ mm and length $l = 71$ mm, connected to a hub with inner diameter $d_h = 224$ mm and outer diameter $D = 350$ mm. The drawing also indicates a fit of $H7/g6$ and a surface finish of $R_{t0.02} = 10 \mu\text{m}$ and $R_{t0.1} = 16 \mu\text{m}$. The calculation table provides the following data:

Parameter	Value	Unit
E-modulus hub	210000	N/mm ²
E-modulus shaft	210000	N/mm ²
Friction coefficient screw	0.1	
Friction coefficient cone	0.05	
Friction coefficient hub/shaft	0.15	
Safety factor	1.1	
Max. transmittable torque	81700	Nm
Max. RPM	1600	min ⁻¹
Moment of inertia	0.7921875	kgm ²
Oversize according to DIN 7190	0.191	mm
Contact pressure hub/shaft	224	N/mm ²
Contact pressure shrink disc/hub	252	N/mm ²
Weight	39	kg

The software interface also shows a list of technical data on the left, including: **3071**, **12 Stk/Pcs**, **M 16 X 70**, **10.9 - DIN 931**, **M_{max} = 250 Nm**, **M_{dyn} = 250 Nm**, and **Torsionskennwert = 7%**. The bottom of the interface displays the company name **TAS SCHÄFER**, the product name **Schrumpfscheibe**, and the part number **3071-200**.

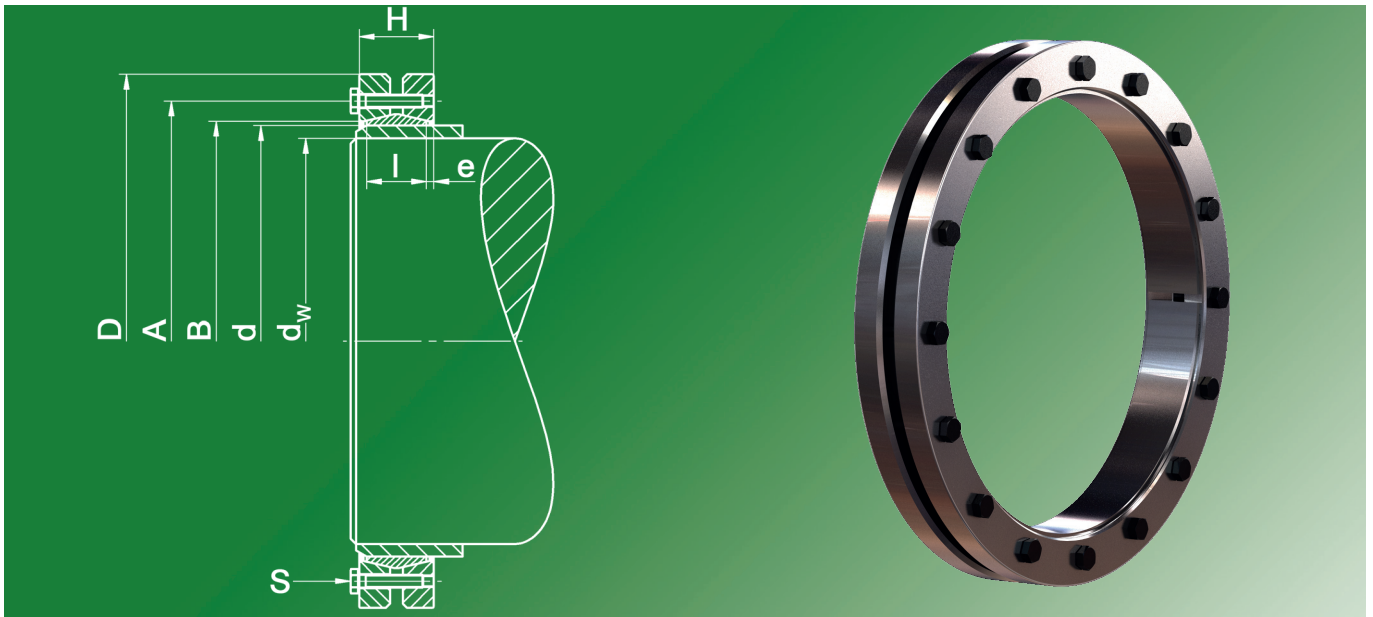

Used symbols

d	[mm]	Nominal diameter of the shrink disc
d_w	[mm]	Shaft diameter
M_{max}	[mm]	Maximal transmittable torque
D	[mm]	Outer diameter
l	[mm]	Length of the inner ring
e	[mm]	Excess length
H	[mm]	Width of the shrink disc
A	[mm]	Pitch circle diameter
B	[mm]	Attachment size
M_A	[Nm]	Tightening torque of the clamping screws
Z		Number of clamping screws
S		Size of the clamping screws
n_{max}	[min ⁻¹]	Permitted rotational frequency
p_N	[N/mm ²]	Moderate pressure to the hub
I	[kgm ²]	Moment of inertia

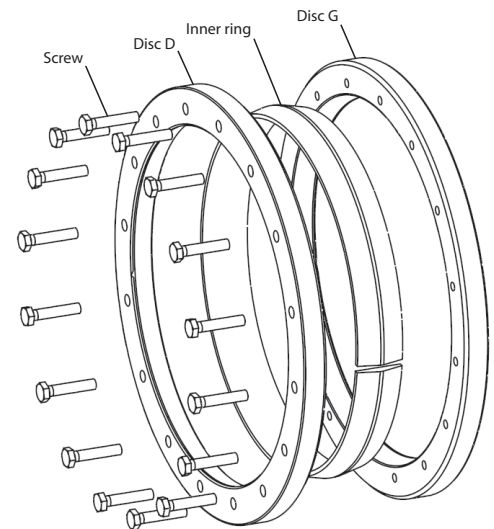

Design of the shrink disc

Discs galvanized

without washers

Dimensions H & e in unlocked position

Variation from the standard shaft diameter d_w

> mm	≤ mm	minimal - mm	maximal + mm
20	60	-2	1
60	100	-2	2
100	160	-3	2
160	220	-4	2
220	300	-5	2

$$M = M_{max(Catalog)} \frac{d_w(target)}{d_w(Catalog)}$$

(see Basics - Calculation)

min. yield strength $R_{p0,2}$	N/mm ²
Solid shaft	290
Hub	350

Ordering information: TAS 3073-d (Further sizes on request)

3073 Mini-Range

<i>d</i> mm	<i>d_w</i> mm	<i>M_{max}</i> Nm	<i>D</i> mm	<i>l</i> mm	<i>e</i> mm	<i>H</i> mm	<i>A</i> mm	<i>B</i> mm	<i>M_A</i> Nm	<i>Z</i> Pcs.	<i>S</i>	<i>DIN</i>	<i>Class</i>	<i>n_{max}</i> min ⁻¹	<i>p_N</i> N/mm ²	<i>I</i> kgm ²	<i>Weight</i> kg
20	18	78	47	10	2	14	34	22	3	4	M 5 x 12	933	8.8	12100	155	0,000424	0,13
24	20	80	52	10	2,5	15	39,5	26	3	5	M 5 x 12	933	8.8	11000	161	0,000697	0,17
25	21	88	56	10	2,5	15	43	30	3	5	M 5 x 12	933	8.8	10200	155	0,000940	0,20
28	24	110	56	10	2,5	15	43	30	3	5	M 5 x 12	933	8.8	10200	138	0,000931	0,19
29	25	110	58	10	2,5	15	44,5	31,5	3	5	M 5 x 12	933	8.8	9800	133	0,001051	0,20
30	26	120	58	10	2,5	15	44,5	31,5	3	5	M 5 x 12	933	8.8	9800	129	0,001066	0,20
31	28	160	60	10	2,5	15	46	33	3	5	M 5 x 12	933	8.8	9500	125	0,001197	0,21
35	30	180	64	10	2,5	15	50	36,5	3	6	M 5 x 12	933	8.8	8900	133	0,001530	0,23
36	31	170	66	10	2,5	15	52	38,5	3	6	M 5 x 12	933	8.8	8600	129	0,001766	0,25
37	32	180	66	10	2,5	15	52	38,5	3	6	M 5 x 12	933	8.8	8600	125	0,001718	0,24
38	33	290	68	10	2,5	15	55	41,5	4	6	M 5 x 12	933	8.8	8400	163	0,001972	0,26
40	35	310	68	10	2,5	15	55	41,5	4	6	M 5 x 12	933	8.8	8400	155	0,001867	0,24
42	37	370	75	14	2,5	19	58	44	4	7	M 5 x 12	933	8.8	7600	123	0,003510	0,38
46	40	460	80	14	2,5	19	63	49	4	8	M 5 x 16	933	8.8	7100	128	0,004471	0,42
47	42	530	80	14	2,5	19	63	49	4	8	M 5 x 16	933	8.8	7100	125	0,004412	0,41
48	43	550	86	14	2,5	19	68,5	53,5	4	8	M 5 x 16	933	8.8	6600	123	0,006062	0,50
51	45	550	86	14	2,5	19	68,5	53,5	4	8	M 5 x 16	933	8.8	6600	115	0,005873	0,47
55	49	710	91	14	2,5	19	73	59	4	9	M 5 x 16	933	8.8	6200	120	0,007349	0,52
56	50	730	91	14	2,5	19	73	59	4	9	M 5 x 16	933	8.8	6200	118	0,007278	0,51
58	52	710	93	14	2,5	19	74	60	4	9	M 5 x 16	933	8.8	6100	114	0,007808	0,52
59	53	840	96	14	2,5	19	77	63	4	10	M 5 x 16	933	8.8	5900	125	0,009047	0,57
60	54	860	96	14	2,5	19	77	63	4	10	M 5 x 16	933	8.8	5900	123	0,008811	0,55
61	55	880	96	14	2,5	19	77	63	4	10	M 5 x 16	933	8.8	5900	121	0,008732	0,54
65	59	970	100	14	2,5	19	82	68	4	10	M 5 x 16	933	8.8	5700	113	0,010135	0,57
66	60	990	100	14	2,5	19	82	68	4	10	M 5 x 16	933	8.8	5700	112	0,010049	0,56
69	63	1500	105	18	3	24	87	73	6	10	M 5 x 20	933	10.9	5400	117	0,015194	0,77
70	65	1600	110	18	3	24	90	76	6	10	M 5 x 20	933	10.9	5200	115	0,018912	0,89
72	67	1600	110	18	3	24	90	76	6	10	M 5 x 20	933	10.9	5200	112	0,018364	0,85
73	68	1700	110	18	3	24	90	76	6	10	M 5 x 20	933	10.9	5200	110	0,018300	0,84
75	70	1700	114	18	3	24	93	78,5	6	10	M 5 x 20	933	10.9	5000	107	0,021181	0,91
78	70	1900	120	18	3	24	101	86	6	12	M 5 x 20	933	10.9	4700	124	0,025605	1,0
81	73	2000	120	18	3	24	101	86	6	12	M 5 x 20	933	10.9	4700	119	0,026201	1,0
83	75	2100	120	18	3	24	101	86	6	12	M 5 x 20	933	10.9	4700	116	0,024748	0,93
85	77	2400	128	22	3	28	105	88,5	12	8	M 6 x 25	933	10.9	4400	103	0,038365	1,3
88	80	2500	130	22	3	28	108	91,5	12	8	M 6 x 25	933	10.9	4400	99	0,040046	1,3
94	85	2500	140	22	3	28	119	102,5	12	8	M 6 x 25	933	10.9	4000	93	0,053318	1,5
95	86	2500	140	22	3	28	119	102,5	12	8	M 6 x 25	933	10.9	4000	92	0,053672	1,5
98	90	2800	140	22	3	28	119	102,5	12	8	M 6 x 25	933	10.9	4000	89	0,051107	1,4
99	91	2800	140	22	3	28	119	102,5	12	8	M 6 x 25	933	10.9	4000	88	0,051452	1,4
100	92	2900	140	22	3	28	119	102,5	12	8	M 6 x 25	933	10.9	4000	87	0,051800	1,4
103	95	3400	150	22	3	28	128	111,5	12	9	M 6 x 25	933	10.9	3800	95	0,070357	1,7
104	96	3500	150	22	3	28	128	111,5	12	9	M 6 x 25	933	10.9	3800	95	0,070796	1,7
105	97	3500	150	22	3	28	128	111,5	12	9	M 6 x 25	933	10.9	3800	94	0,067050	1,6
108	100	3700	150	22	3	28	128	111,5	12	9	M 6 x 25	933	10.9	3800	91	0,064058	1,5
112	104	3800	158	22	3	28	135	118,5	12	9	M 6 x 25	933	10.9	3600	88	0,084393	1,8
115	107	4000	158	22	3	28	135	118,5	12	9	M 6 x 25	933	10.9	3600	85	0,081152	1,7

3073 Mini-Range

d mm	d_w mm	M_{max} Nm	D mm	l mm	e mm	H mm	A mm	B mm	M_A Nm	Z Pcs.	S	DIN	Class	n_{max} min ⁻¹	p_N N/mm ²	I kgm ²	Weight kg
120	110	4300	164	25	3,5	32	141	123,5	12	10	M 6 x 25	933	10.9	3400	80	0,0103240	2,0
125	115	4600	169	25	3,5	32	146	128,5	12	10	M 6 x 25	933	10.9	3300	77	0,0115988	2,1
130	120	6000	179	25	3,5	32	156	138,5	12	12	M 6 x 25	933	10.9	3200	89	0,0146823	2,4
135	125	6200	179	25	3,5	32	156	138,5	12	12	M 6 x 25	933	10.9	3200	85	0,0138232	2,2
138	128	6400	182	25	3,5	32	161	143,5	12	12	M 6 x 25	933	10.9	3100	84	0,0149983	2,3
140	130	6500	182	25	3,5	32	161	143,5	12	12	M 6 x 25	933	10.9	3100	82	0,0144991	2,2
145	135	6800	194	25	3,5	32	171	153,5	12	12	M 6 x 25	933	10.9	2900	80	0,0197981	2,7
150	140	7100	194	25	3,5	32	171	153,5	12	12	M 6 x 25	933	10.9	2900	77	0,0180408	2,4
160	150	7700	204	25	3,5	32	181	163,5	12	12	M 6 x 25	933	10.9	2800	72	0,0218452	2,6
166	156	7900	210	25	3,5	32	187	169,5	12	12	M 6 x 25	933	10.9	2700	69	0,0241839	2,7
167	157	9500	214	25	3,5	32	191	173,5	12	14	M 6 x 25	933	10.9	2600	81	0,0267108	2,9
170	160	9700	214	25	3,5	32	191	173,5	12	14	M 6 x 25	933	10.9	2600	79	0,0252099	2,7
173	163	9900	220	25	3,5	32	196	178,5	12	14	M 6 x 25	933	10.9	2600	78	0,0293734	3,0
175	165	10100	220	25	3,5	32	196	178,5	12	14	M 6 x 25	933	10.9	2600	77	0,0286466	2,9
180	170	10400	225	25	3,5	32	201	183,5	12	14	M 6 x 25	933	10.9	2500	75	0,0300966	2,9
185	175	11600	230	25	3,5	32	206	188,5	12	15	M 6 x 25	933	10.9	2400	78	0,0326719	3,0
192	180	11500	240	28	3,5	35	220	200,5	12	15	M 6 x 30	933	10.9	2300	67	0,0436896	3,7
195	183	11600	240	28	3,5	35	220	200,5	12	15	M 6 x 30	933	10.9	2300	66	0,0418359	3,5
198	186	12700	250	28	3,5	35	225	206	12	16	M 6 x 30	933	10.9	2200	69	0,0533946	4,2
202	190	13100	250	28	3,5	35	225	206	12	16	M 6 x 30	933	10.9	2200	68	0,0503607	3,9
212	200	13900	260	28	3,5	35	235	216	12	16	M 6 x 30	933	10.9	2200	65	0,0576788	4,1
214	202	16000	270	28	3,5	35	245	226	12	18	M 6 x 30	933	10.9	2100	72	0,0727013	4,9
215	203	16100	270	28	3,5	35	245	226	12	18	M 6 x 30	933	10.9	2100	72	0,0714750	4,8
220	208	16600	270	28	3,5	35	245	226	12	18	M 6 x 30	933	10.9	2100	70	0,0667150	4,4
222	210	16700	270	28	3,5	35	245	226	12	18	M 6 x 30	933	10.9	2100	70	0,0641466	4,2
230	218	17500	280	28	3,5	35	255	236	12	18	M 6 x 30	933	10.9	2000	67	0,0754975	4,6
232	220	17700	280	28	3,5	35	255	236	12	18	M 6 x 30	933	10.9	2000	67	0,0727232	4,4
235	223	17900	290	28	3,5	35	265	246	12	18	M 6 x 30	933	10.9	1900	66	0,0905613	5,2
236	224	18000	290	28	3,5	35	265	246	12	18	M 6 x 30	933	10.9	1900	65	0,0891199	5,1
242	230	18600	290	28	3,5	35	265	246	12	18	M 6 x 30	933	10.9	1900	64	0,0820318	4,6
252	240	19500	300	28	3,5	35	276	256	12	18	M 6 x 30	933	10.9	1900	61	0,0901836	4,7
257	245	22400	310	28	3,5	35	286	266	12	20	M 6 x 30	933	10.9	1800	67	0,1094506	5,4
262	250	22900	310	28	3,5	35	286	266	12	20	M 6 x 30	933	10.9	1800	66	0,1009057	4,9
266	254	25600	325	28	3,5	35	291	271	12	22	M 6 x 30	933	10.9	1700	71	0,1366953	6,2
278	265	28900	352	32	4	40	304	284	12	24	M 6 x 30	933	10.9	1600	65	0,2389108	9,5
280	267	29200	352	32	4	40	304	286	12	24	M 6 x 30	933	10.9	1600	64	0,2351784	9,3
298	283	30600	370	32	4	40	322	302	12	24	M 6 x 30	933	10.9	1500	60	0,2764874	9,8
300	285	30900	370	32	4	40	324	304	12	24	M 6 x 30	933	10.9	1500	60	0,2722800	9,6
310	285	31000	385	32	4	40	334	314	12	26	M 6 x 30	933	10.9	1400	63	0,3359469	11
335	300	51800	410	34	5	44	365	340	30	20	M 8 x 35	933	10.9	1300	88	0,3854469	11
350	320	23700	405	28	4,5	37	374,7	357	18	15	M 8 x 30	933	10.9	1400	46	0,2650356	7,4
360	330	71400	450	40	5	50	390	366	30	24	M 8 x 40	933	10.9	1200	83	0,7472250	18
370	340	53500	455	42	5	52	400	376	30	18	M 8 x 40	933	10.9	1200	58	0,7738312	18
380	340	52000	455	32	6	44	410	386	30	18	M 8 x 30	933	10.9	1200	74	0,6149938	14



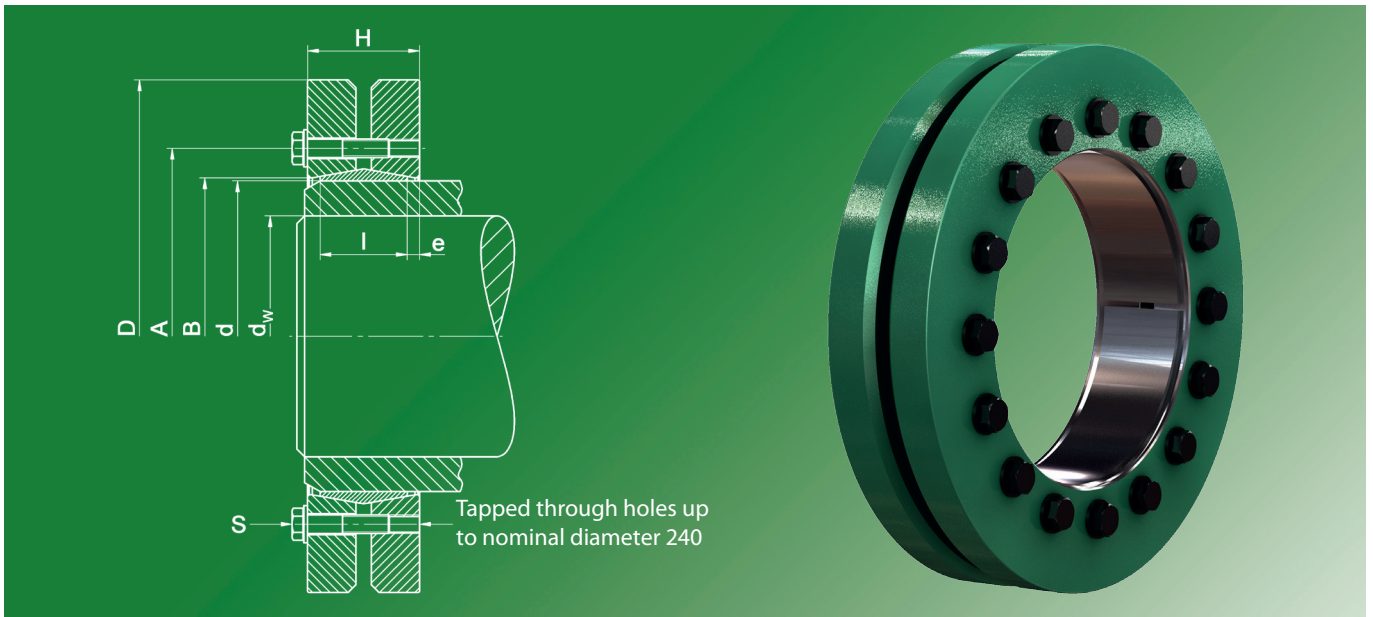

Used symbols

d	[mm]	Nominal diameter of the shrink disc
d_w	[mm]	Shaft diameter
M_{max}	[mm]	Maximal transmittable torque
D	[mm]	Outer diameter
l	[mm]	Length of the inner ring
e	[mm]	Excess length
H	[mm]	Width of the shrink disc
A	[mm]	Pitch circle diameter
B	[mm]	Attachment size
M_A	[Nm]	Tightening torque of the clamping screws
Z		Number of clamping screws
S		Size of the clamping screws
n_{max}	[min ⁻¹]	Permitted rotational frequency
p_N	[N/mm ²]	Moderate pressure to the hub
I	[kgm ²]	Moment of inertia

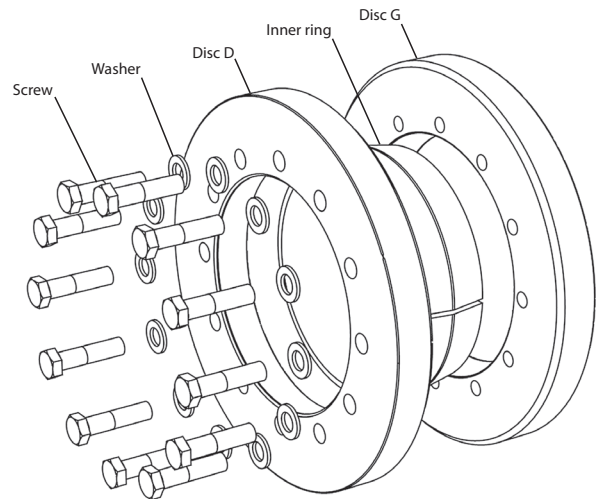

Design of the shrink disc

$d < 140$ - Discs galvanized - without washers

$d \geq 140$ - Discs painted - with washers

Dimensions **H** & **e** in unlocked position

Hexagon head bolts are used as standard.

Upon request we provide all sized shrink discs with hexagon socket head bolts (Inbus). (See ordering information)

Variation from the standard shaft diameter d_w

> mm	≤ mm	minimal - mm	maximal + mm
100	170	-5	5
170	230	-10	5
230	320	-10	10
320	480	-15	10
480	510	-20	10

$$M = M_{max (Catalog)} \frac{d_w (target)}{d_w (Catalog)}$$

(see Basics - Calculation)

min. yield strength $R_{p0,2}$	N/mm ²
Solid shaft	290
Hub	350

Ordering information: TAS 3051 - d (e.g.: TAS 3051-200 ... further sizes on request)
with Inbus: TAS 3051 - d - Inbus (e.g.: TAS 3051-200-Inbus)

3051 Light-Range

d mm	d_w mm	M_{max} Nm	D mm	l mm	e mm	H mm	A mm	B mm	M_A Nm	Z Stk	S	DIN	Class	n_{max} min ⁻¹	p_N N/mm ²	I kgm ²	Weight kg
120	100	11900	185	39	6	51	158	129	59	8	M 10 x 40	931	10.9	3000	169	0,0328219	5,4
125	100	10900	185	39	6	51	158	129	59	8	M 10 x 40	931	10.9	3000	163	0,0317794	5,1
140	120	17300	220	39	6	51	175	144	59	9	M 10 x 40	931	10.9	2600	163	0,0663000	7,8
155	135	24800	245	39	6	51	192	159	59	11	M 10 x 40	931	10.9	2300	180	0,1029612	9,8
165	140	33100	260	46	8	62	210	169	100	10	M 12 x 50	931	10.9	2200	190	0,1540906	13
175	150	40000	275	46	8	62	220	179	100	11	M 12 x 50	931	10.9	2000	198	0,1859375	14
185	160	47000	295	46	8	62	225	189	100	12	M 12 x 50	931	10.9	1900	204	0,2576562	17
195	170	63400	315	56	8	72	237	199	100	15	M 12 x 55	931	10.9	1800	199	0,3945938	23
200	180	75700	330	56	8	72	242	204	100	16	M 12 x 55	931	10.9	1700	207	0,4839250	26
220	190	96500	345	66	9	84	265	224	250	10	M 16 x 70	931	10.9	1600	205	0,6487719	31
240	210	132000	370	66	9	84	290	244	250	12	M 16 x 70	931	10.9	1500	226	0,8509	35
260	230	172000	395	72	10	92	310	265	250	14	M 16 x 70	931	10.9	1400	223	1,2299	44
280	240	196000	425	84	10	104	333	285	250	16	M 16 x 75	931	10.9	1300	203	1,8779	58
300	260	243000	460	84	10	104	358	305	250	18	M 16 x 75	931	10.9	1200	213	2,6013	69
320	280	297000	495	84	11	106	378	325	250	20	M 16 x 75	931	10.9	1100	222	3,6914	85
340	300	339000	535	84	11	106	402	345	250	21	M 16 x 75	931	10.9	1000	219	5,0730	101
350	300	388000	545	100	11	122	413	360	490	16	M 20 x 90	931	10.9	1000	213	6,0831	116
360	310	404000	555	100	11	122	423	365	490	16	M 20 x 90	931	10.9	1000	207	6,5097	119
380	330	487000	585	112	12	136	442	387	490	18	M 20 x 100	931	10.9	970	197	8,94	147
390	340	564000	595	112	12	136	452	397	490	20	M 20 x 100	931	10.9	960	214	9,49	150
400	350	614000	615	112	12	136	462	407	490	21	M 20 x 100	931	10.9	930	219	10,90	162
420	360	643000	630	120	12	144	485	427	490	22	M 20 x 100	931	10.9	900	204	12,47	174
440	380	751000	660	120	12	144	505	447	490	24	M 20 x 100	931	10.9	860	212	15,02	191
460	400	934000	685	132	13	158	527	468	490	28	M 20 x 110	931	10.9	830	215	19,23	226
480	420	981000	715	132	13	158	547	488	490	28	M 20 x 110	931	10.9	800	206	22,80	246
500	440	1113000	750	132	13	158	567	508	490	30	M 20 x 110	931	10.9	760	212	27,83	274
530	470	1319000	800	150	12,5	175	600	540	490	33	M 20 x 120	931	10.9	710	194	39,83	346
560	500	1550000	850	150	12,5	175	630	570	490	36	M 20 x 120	931	10.9	670	200	51,03	394
590	530	1652000	870	150	12,5	175	676	602	490	36	M 20 x 130	931	10.9	650	190	54,42	394
620	560	1759000	880	150	12,5	175	686	624	490	36	M 20 x 130	931	10.9	650	181	54,46	376

3051 HALF / SPLIT Light-Range

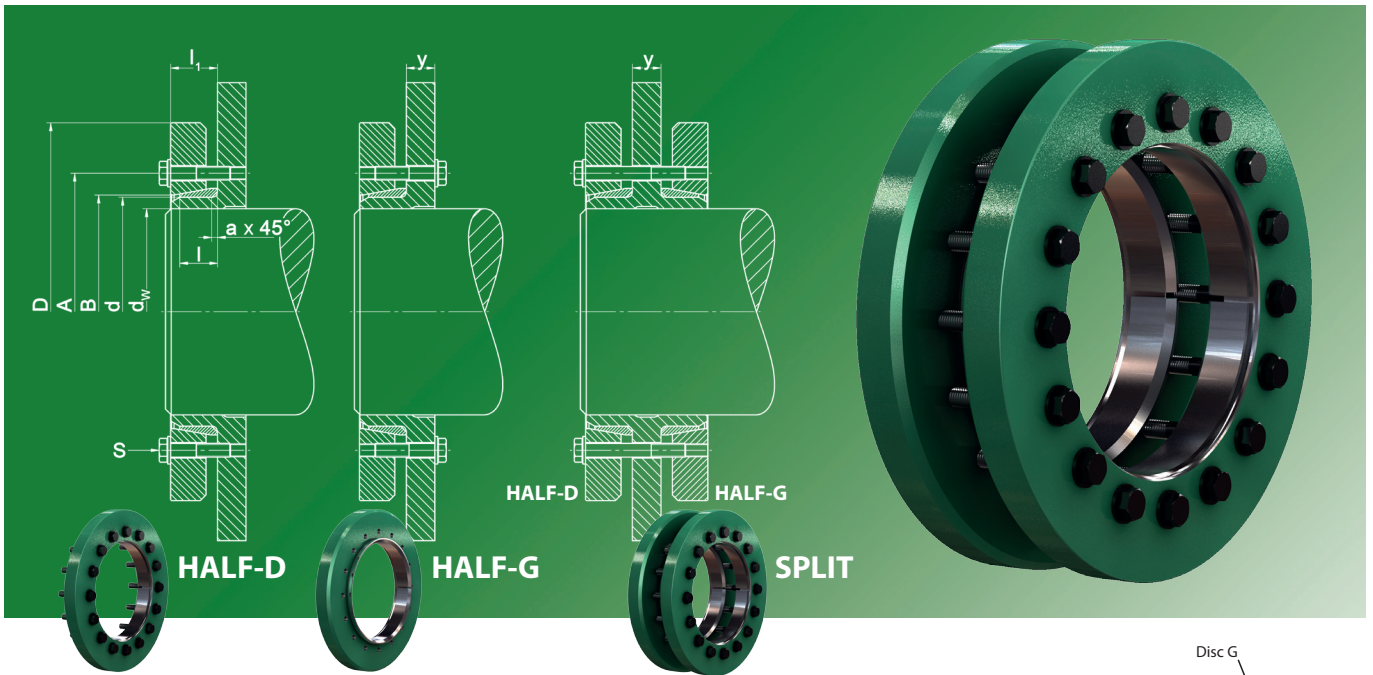

Used symbols

d	[mm]	Nominal diameter of the shrink disc
d_w	[mm]	Shaft diameter
M_{max}	[mm]	Maximal transmittable torque
D	[mm]	Outer diameter
l	[mm]	Length of the inner ring
a	[mm]	Width of the chamfer on the inner ring
l_1	[mm]	Width of the shrink disc
A	[mm]	Pitch circle diameter
B	[mm]	Attachment size
M_A	[Nm]	Tightening torque of the clamping screws
Z		Number of clamping screws
S		Size of the clamping screws
n_{max}	[min ⁻¹]	Permitted rotational frequency
p_N	[N/mm ²]	Moderate pressure to the hub
I	[kgm ²]	Moment of inertia

Design of the shrink disc

$d < 140$ - Discs galvanized - without washers

$d \geq 140$ - Discs painted - with washers

Dimensions **H** & **e** in unlocked position

Deviation from the standard shaft diameter d_w
see the table „3051 Light-Range“
and „Calculation of transmissible torques and forces“

Hexagon head bolts are used as standard.
Upon request we provide all sized shrink discs with hexagon socket head bolts (Inbus). (See ordering information)

For **Typ** in ordering information:
GET means **SPLIT**
HALB means **HALF**

min. yield strength $R_{p0.2}$	N/mm ²
Solid shaft	290
Hub	350

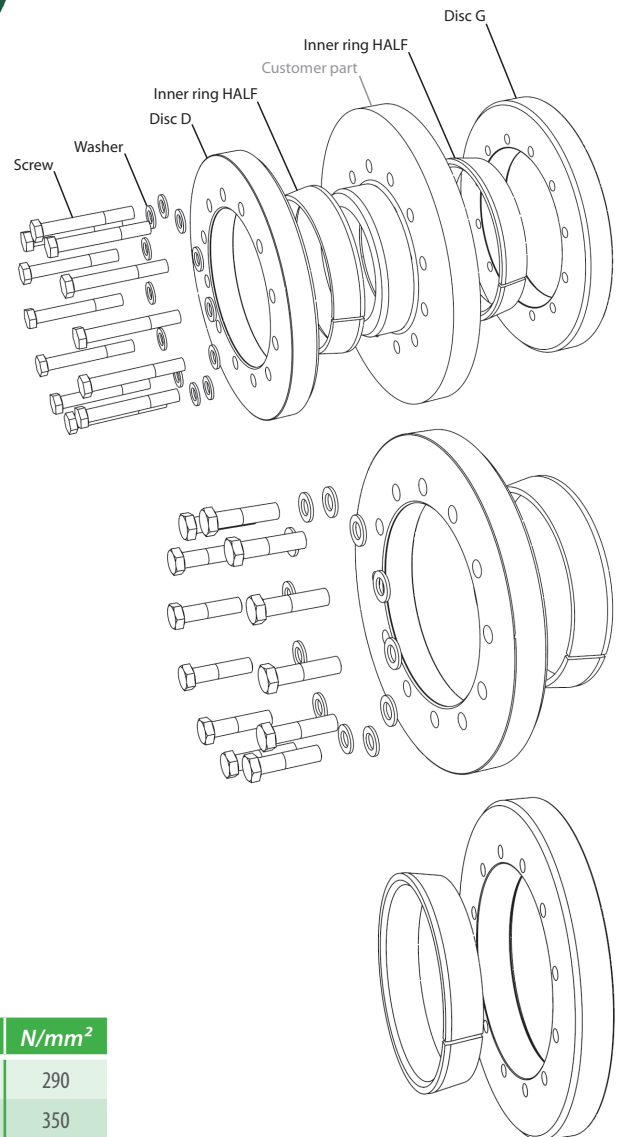

Ordering information: TAS 3051Type - d - y (e.g.: TAS 3051GET-200-Y60 or TAS 3051HALB-G-200-Y30 or TAS 3051HALB-D-200)

with Inbus: TAS 3051Type - d - y - Inbus (e.g.: TAS 3051GET-200-Y60-Inbus etc.)

(Further sizes on request)

3051 HALF / SPLIT Light-Range

Please note:

All values refer to shrink disk design **HALF!**

Please provide us the dimension of „y“ or the length of screws. Otherwise we can not provide appropriate screws!
(see ordering information)

Applies to shrink disc design **HALF-G:**

- The required screw length is: $Screw\ length\ (3051\ Light-Range) - l_1 + 2a + y$ (rounded up to standard lengths)

Applies to shrink disc design **SPLIT:**

- The design consists of 1x **HALF-D** + 1x **HALF-G**
- Delivery is possible with or without screws
- Maximum transmittable torque: $M_{ges} = 2 M_{max}$
- The required screw length: $Screw\ length\ (3051\ Light-Range) + 2a + y$ (rounded up to standard lengths)

d mm	d _w mm	M _{max} Nm	D mm	l mm	a mm	l ₁ mm	A mm	B mm	M _A Nm	Z Stk	HALF-D only				n _{max} min ⁻¹	p _N N/mm ²	I kgm ²	Weight kg
											d _B mm	S	DIN	Class				
120	100	5900	185	24,5	5	30,5	158	129	59	8	11	M 10 x 40	931	10.9	3000	169	0,0164109	2,7
125	100	5400	185	24,5	5	30,5	158	129	59	8	11	M 10 x 40	931	10.9	3000	163	0,0155781	2,5
140	120	8600	220	24,5	5	30,5	175	144	59	9	11	M 10 x 40	931	10.9	2600	163	0,0331500	3,9
155	135	12400	245	24,5	5	30,5	192	159	59	11	11	M 10 x 40	931	10.9	2300	180	0,0514806	4,9
165	140	16500	260	28	5	36	210	169	100	10	13,5	M 12 x 50	931	10.9	2200	190	0,0770453	6,5
175	150	20000	275	28	5	36	220	179	100	11	13,5	M 12 x 50	931	10.9	2000	198	0,0956250	7,2
185	160	23500	295	28	5	36	225	189	100	12	13,5	M 12 x 50	931	10.9	1900	204	0,1288281	8,5
195	170	31700	315	33	5	41	237	199	100	15	13,5	M 12 x 55	931	10.9	1800	199	0,2058750	12
200	180	37800	330	33	5	41	242	204	100	16	13,5	M 12 x 55	931	10.9	1700	207	0,2419625	13
220	190	48200	345	41	6	50	265	224	250	10	17,5	M 16 x 70	931	10.9	1600	205	0,3348500	16
240	210	66100	370	41	6	50	290	244	250	12	17,5	M 16 x 70	931	10.9	1500	226	0,4376250	18
260	230	86200	395	44	6	54	310	265	250	14	17,5	M 16 x 70	931	10.9	1400	223	0,6149687	22
280	240	98100	425	52	8	62	333	285	250	16	17,5	M 16 x 80	931	10.9	1300	203	0,9390	29
300	260	121000	460	52	8	62	358	305	250	18	17,5	M 16 x 80	931	10.9	1200	213	1,3195	35
320	280	148000	495	52	8	63	378	325	250	20	17,5	M 16 x 80	931	10.9	1100	222	1,8240	42
340	300	169000	535	52	8	63	402	345	250	21	17,5	M 16 x 80	931	10.9	1000	219	2,5616	51
350	305	202000	545	60	10	71	413	360	490	16	22	M 20 x 90	931	10.9	1000	213	3,0416	58
360	310	202000	555	60	10	71	423	365	490	16	22	M 20 x 90	931	10.9	1000	207	3,2275	59
380	330	243000	585	69	12	81	442	387	490	18	22	M 20 x 100	931	10.9	970	197	4,4405	73
390	340	282000	595	69	12	81	452	397	490	20	22	M 20 x 100	931	10.9	960	214	4,7449	75
400	350	307000	615	69	12	81	462	407	490	21	22	M 20 x 100	931	10.9	930	219	5,4495	81
420	360	321000	630	73	12	85	485	427	490	22	22	M 20 x 110	931	10.9	900	204	6,2346	87
440	380	375000	660	73	12	85	505	447	490	24	22	M 20 x 110	931	10.9	860	212	7,5504	96
460	400	467000	685	79	14	92	527	468	490	28	22	M 20 x 120	931	10.9	830	215	9,6167	113
480	420	490000	715	81	14	94	547	488	490	28	22	M 20 x 120	931	10.9	800	206	11,40	123
500	440	556000	750	81	14	94	567	508	490	30	22	M 20 x 120	931	10.9	760	212	13,91	137
530	470	659000	800	90	14	102,5	600	540	490	33	22	M 20 x 120	931	10.9	710	194	19,91	173
560	500	775000	850	90	14	102,5	630	570	490	36	22	M 20 x 120	931	10.9	670	200	25,51	197
590	530	826000	870	90	14	102,5	676	602	490	36	22	M 20 x 130	931	10.9	650	190	27,21	197
620	560	879000	880	90	14	102,5	686	624	490	36	22	M 20 x 130	931	10.9	650	181	27,23	188

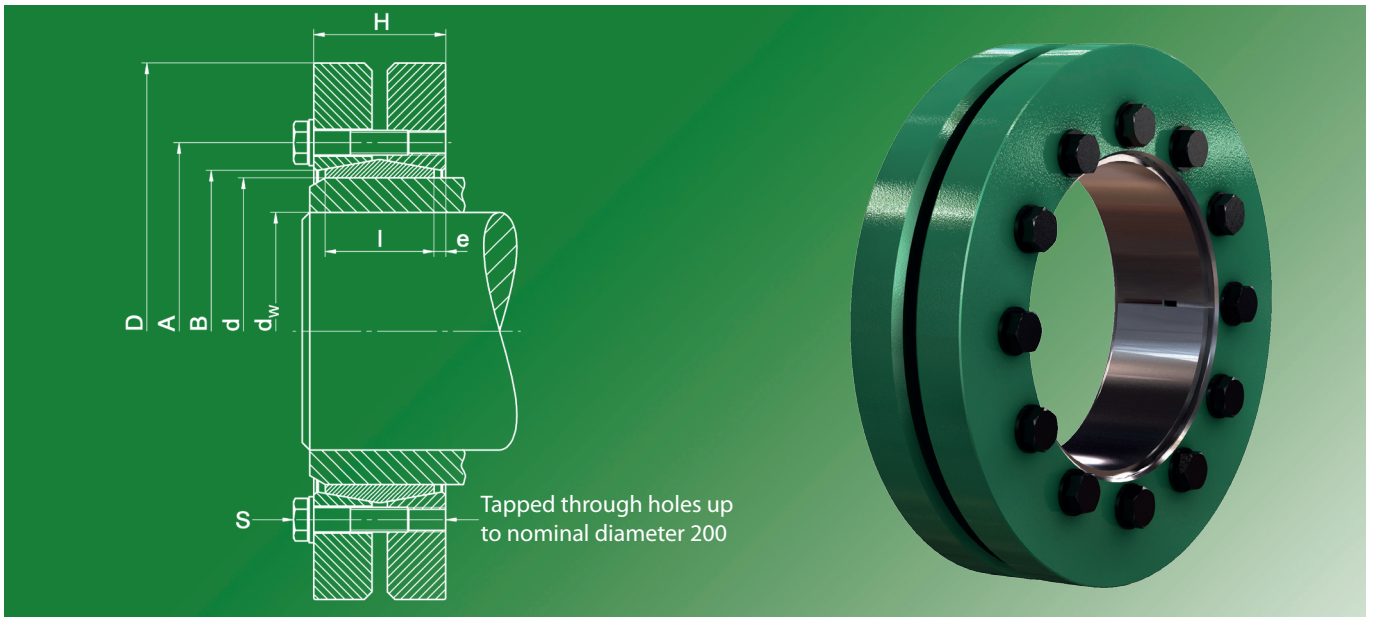

Used symbols

d	[mm]	Nominal diameter of the shrink disc
d_w	[mm]	Shaft diameter
M_{max}	[mm]	Maximal transmittable torque
D	[mm]	Outer diameter
l	[mm]	Length of the inner ring
e	[mm]	Excess length
H	[mm]	Width of the shrink disc
A	[mm]	Pitch circle diameter
B	[mm]	Attachment size
M_A	[Nm]	Tightening torque of the clamping screws
Z		Number of clamping screws
S		Size of the clamping screws
n_{max}	[min ⁻¹]	Permitted rotational frequency
p_N	[N/mm ²]	Moderate pressure to the hub
I	[kgm ²]	Moment of inertia

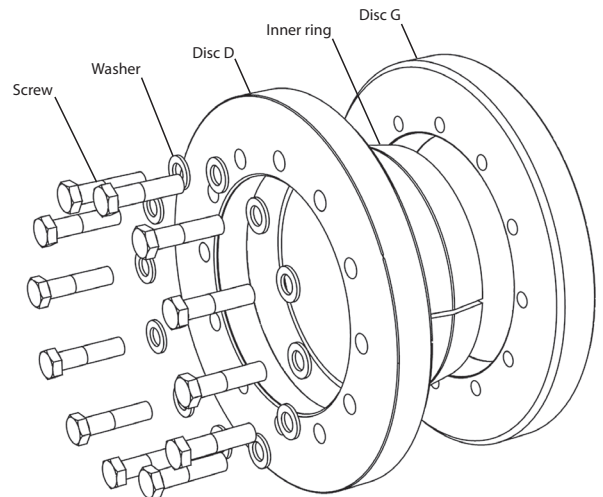

Design of the shrink disc

$d < 115$ - Discs galvanized - without washers

$d \geq 115$ - Discs painted - with washers

Dimensions **H** & **e** in unlocked position

Hexagon head bolts are used as standard.

Upon request we provide all sized shrink discs with hexagon socket head bolts (Inbus). (See ordering information)

Variation from the standard shaft diameter d_w

> mm	≤ mm	minimal - mm	maximal + mm
10	30	-1	1
30	50	-3	2
50	140	-5	5
140	180	-10	5
180	320	-15	10
320	500	-20	10
500	700	-30	20
700	820	-40	20

min. yield strength $R_{p0,2}$	N/mm ²
Solid shaft	290
Hub	350

$$M = M_{max(Katalog)} \frac{d_w(soll)}{d_w(Katalog)}$$

(see Basics - Calculation)

Ordering information: TAS 3071 - d (e.g.: TAS 3071-200 ... further sizes on request)
with Inbus: TAS 3071 - d - Inbus (e.g.: TAS 3071-200-Inbus)

3071 Standard-Range

<i>d</i> mm	<i>d_w</i> mm	<i>M_{max}</i> Nm	<i>D</i> mm	<i>l</i> mm	<i>e</i> mm	<i>H</i> mm	<i>A</i> mm	<i>B</i> mm	<i>M_A</i> Nm	<i>Z</i> Stk	<i>S</i>	<i>DIN</i>	<i>Class</i>	<i>n_{max}</i> min ⁻¹	<i>p_N</i> N/mm ²	<i>I</i> kgm ²	<i>Weight</i> kg
14	11	27	37	9	1,5	12	24	15	2,4	3	M 4 x 10	933	8.8	15400	254	0,000137	0,07
16	13	59	41	12	1,5	15	27	17	4,8	3	M 5 x 12	933	8.8	13900	240	0,000266	0,11
18	15	110	43	12	1,5	15	29	19	4,8	4	M 5 x 12	933	8.8	13300	285	0,000326	0,12
20	17	220	48	14	2,75	19,5	34	24	6	5	M 5 x 18	933	10.9	11900	322	0,000642	0,19
21	18	240	48	14	2,75	19,5	34	24	6	5	M 5 x 18	933	10.9	11900	307	0,000618	0,18
22	19	250	48	14	2,75	19,5	36	26	6	5	M 5 x 18	933	10.9	11900	293	0,000627	0,18
24	20	300	50	14	2,5	19	36	26	6	6	M 5 x 18	933	10.9	11400	322	0,000731	0,19
30	25	360	60	16	2,75	21,5	44	32	6	6	M 5 x 18	931	10.9	9500	225	0,001687	0,30
36	30	640	72	18	2,75	23,5	52	38	12	5	M 6 x 20	933	10.9	7900	231	0,003888	0,48
38	31	910	80	20	3	26	56	41	12	7	M 6 x 25	933	10.9	7100	275	0,006569	0,67
40	32	740	75	19	2,75	24,5	57	43	12	6	M 6 x 20	933	10.9	7600	236	0,004967	0,55
41	33	940	80	20	2,75	25,5	61	46	12	7	M 6 x 20	933	10.9	7100	255	0,006465	0,64
44	35	970	80	20	2,75	25,5	61	47	12	7	M 6 x 20	933	10.9	7100	238	0,006356	0,61
50	40	1200	90	22	3	28	70	53	12	8	M 6 x 25	933	10.9	6300	217	0,010998	0,83
55	45	1500	100	23	3,75	30,5	75	58	12	8	M 6 x 25	933	10.9	5700	189	0,017909	1,1
62	50	2100	110	23	3,75	30,5	86	66	12	10	M 6 x 25	933	10.9	5200	210	0,025909	1,3
68	55	2200	115	23	3,75	30,5	86	72	12	10	M 6 x 25	933	10.9	4900	191	0,031236	1,4
75	60	3600	138	25	3,75	32,5	100	79	30	7	M 8 x 30	933	10.9	4100	233	0,070923	2,3
80	65	4100	145	25	3,75	32,5	100	84	30	7	M 8 x 30	933	10.9	3900	218	0,085703	2,5
90	70	6000	155	30	4,5	39	114	94	30	10	M 8 x 35	931	10.9	3600	231	0,132516	3,3
100	75	7300	170	34	5	44	124	104	30	12	M 8 x 35	931	10.9	3300	220	0,213950	4,4
110	80	8900	185	39	5,5	50	136	114	59	9	M 10 x 40	931	10.9	3000	208	0,347437	6,0
115	80	9300	200	40	5	50	150	124	59	10	M 10 x 40	931	10.9	2800	215	0,0485678	7,3
120	85	9600	200	40	5	50	150	124	59	10	M 10 x 40	931	10.9	2800	206	0,0476000	7,0
125	90	13100	215	42	6	54	160	134	59	12	M 10 x 40	931	10.9	2600	226	0,0672619	8,7
140	100	17900	230	46	7,25	60,5	175	146	100	10	M 12 x 45	931	10.9	2400	224	0,0996875	11
155	110	23900	265	50	7,25	64,5	192	165	100	12	M 12 x 50	931	10.9	2100	224	0,1885000	16
165	120	38700	290	56	7,5	71	210	175	250	8	M 16 x 55	931	10.9	1900	258	0,3061438	22
175	130	42600	300	56	7,5	71	220	185	250	8	M 16 x 55	931	10.9	1900	243	0,3467969	23
185	140	59000	330	71	7,5	86	236	195	250	10	M 16 x 70	931	10.9	1700	227	0,6261719	35
195	150	79500	350	71	7,5	86	246	210	250	12	M 16 x 70	931	10.9	1600	258	0,8026250	40
200	155	81700	350	71	7,5	86	246	210	250	12	M 16 x 70	931	10.9	1600	252	0,7921875	39
220	165	103000	370	88	8	104	270	230	250	15	M 16 x 80	931	10.9	1500	231	1,1813	51
240	180	144000	405	92	8,5	109	295	248	490	12	M 20 x 80	931	10.9	1400	254	1,7730	64
245	185	147000	410	95	8	111	298	251	490	12	M 20 x 80	931	10.9	1300	241	1,9105	67
260	190	170000	440	103	8,5	120	321	268	490	14	M 20 x 90	931	10.9	1300	244	2,7426	84
280	210	224000	460	114	10	134	346	288	490	16	M 20 x 100	931	10.9	1200	234	3,5888	99
300	230	287000	485	122	10	142	364	308	490	18	M 20 x 100	931	10.9	1100	230	4,6751	115
320	240	326000	520	122	10	142	386	328	490	20	M 20 x 100	931	10.9	1100	239	6,1978	133
340	250	401000	570	134	11	156	408	348	490	24	M 20 x 110	931	10.9	1000	246	10,08	183
350	270	456000	580	140	11	162	432	358	490	24	M 20 x 110	931	10.9	980	229	11,07	193
360	290	519000	590	140	11	162	432	368	490	24	M 20 x 110	931	10.9	970	222	11,76	197
380	300	635000	645	144	12	168	458	387	840	20	M 24 x 120	931	10.9	880	245	17,86	255
390	310	697000	660	144	12	168	468	397	840	21	M 24 x 120	931	10.9	860	251	19,54	266
400	320	722000	680	144	12	168	480	407	840	21	M 24 x 120	931	10.9	840	245	22,10	284
420	340	891000	690	164	12	188	504	427	840	24	M 24 x 130	931	10.9	830	234	25,94	318

3071 Standard-Range

<i>d</i> mm	<i>d_w</i> mm	<i>M_{max}</i> Nm	<i>D</i> mm	<i>l</i> mm	<i>e</i> mm	<i>H</i> mm	<i>A</i> mm	<i>B</i> mm	<i>M_A</i> Nm	<i>Z</i> Stk	<i>S</i>	<i>DIN</i>	<i>Class</i>	<i>n_{max}</i> min ⁻¹	<i>p_N</i> N/mm ²	<i>I</i> kgm ²	<i>Weight</i> kg
440	350	891000	750	177	12,5	202	527	447	840	24	M 24 x 140	931	10.9	760	207	39,13	414
460	370	1127000	770	177	12,5	202	547	468	840	28	M 24 x 140	931	10.9	740	231	43,04	428
480	390	1290000	800	188	12,5	213	570	488	840	30	M 24 x 140	931	10.9	710	223	52,77	485
500	410	1431000	850	188	12,5	213	590	508	1250	24	M 27 x 150	931	10.9	670	225	68,08	560
530	440	1961000	900	215	12,5	240	620	538	1250	30	M 27 x 180	931	10.9	630	232	93,54	686
560	460	2165000	950	215	12,5	240	650	568	1250	32	M 27 x 180	931	10.9	600	234	116	763
590	480	2514000	980	235	15	265	685	600	1250	36	M 27 x 180	931	10.9	580	229	142	869
620	510	2856000	1020	235	15	265	715	630	1250	38	M 27 x 180	931	10.9	560	230	166	931
660	540	3676000	1100	260	15	290	760	670	1700	38	M 30 x 200	931	10.9	520	238	246	1195
700	580	4232000	1200	260	15	290	800	710	1700	40	M 30 x 200	931	10.9	470	236	354	1466
720	600	4639000	1230	260	15	290	820	730	1700	42	M 30 x 200	931	10.9	460	241	390	1535
750	620	4967000	1230	280	17,5	315	855	762	1700	44	M 30 x 220	931	10.9	460	225	420	1619
800	660	5501000	1310	280	17,5	315	905	812	1700	46	M 30 x 220	931	10.9	430	220	540	1833
850	700	6322000	1330	310	17,5	345	965	862	1700	50	M 30 x 250	931	10.9	430	204	604	1938
900	740	6950000	1400	310	17,5	345	1015	912	1700	52	M 30 x 250	931	10.9	400	200	738	2130
950	780	8421000	1550	340	20	380	1075	962	2800	42	M 36 x 260	931	10.9	370	199	1285	3111
1000	820	10562000	1620	340	20	380	1125	1012	2800	50	M 36 x 260	931	10.9	350	225	1526	3369

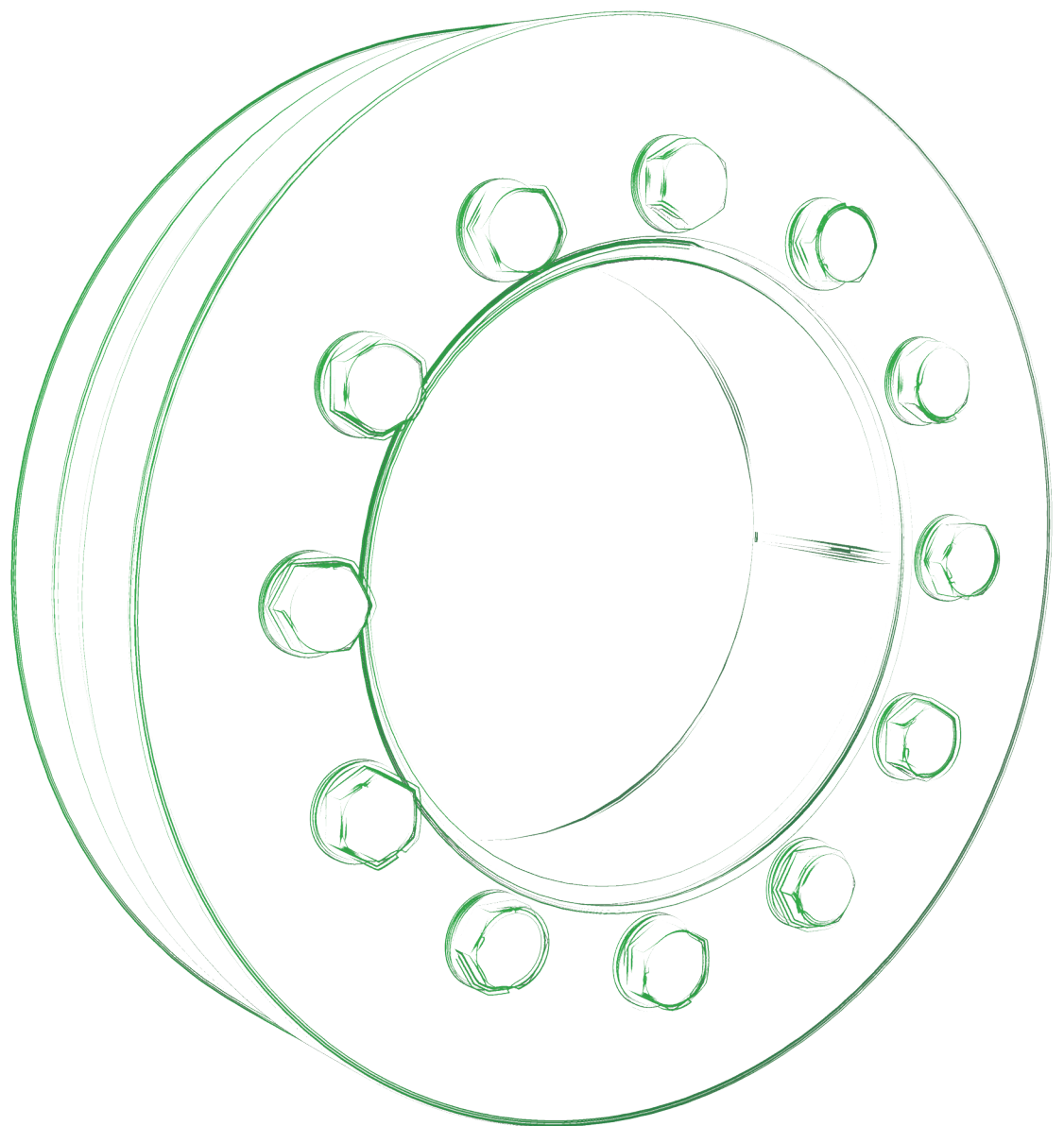

3071 HALF / SPLIT Standard-Range

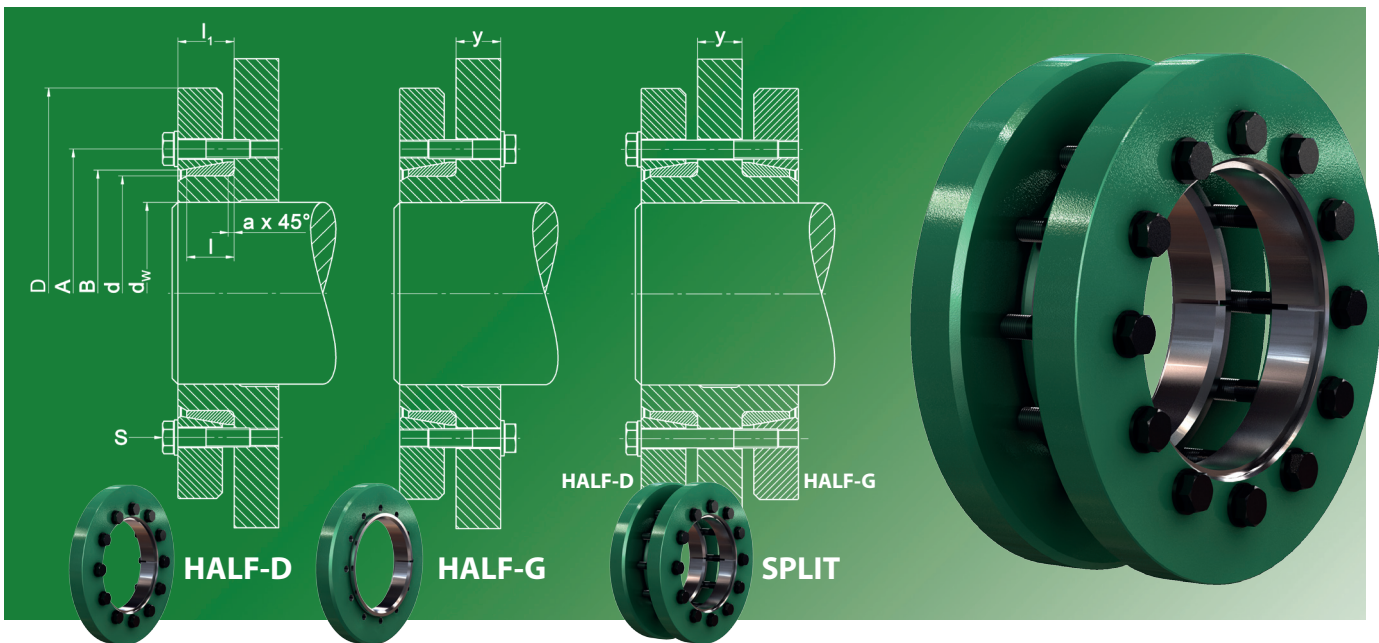

Used symbols

d	[mm]	Nominal diameter of the shrink disc
d_w	[mm]	Shaft diameter
M_{max}	[mm]	Maximal transmittable torque
D	[mm]	Outer diameter
l	[mm]	Length of the inner ring
a	[mm]	Width of the chamfer on the inner ring
l_1	[mm]	Width of the shrink disc
A	[mm]	Pitch circle diameter
B	[mm]	Attachment size
M_A	[Nm]	Tightening torque of the clamping screws
Z		Number of clamping screws
S		Size of the clamping screws
n_{max}	[min ⁻¹]	Permitted rotational frequency
p_N	[N/mm ²]	Moderate pressure to the hub
I	[kgm ²]	Moment of inertia

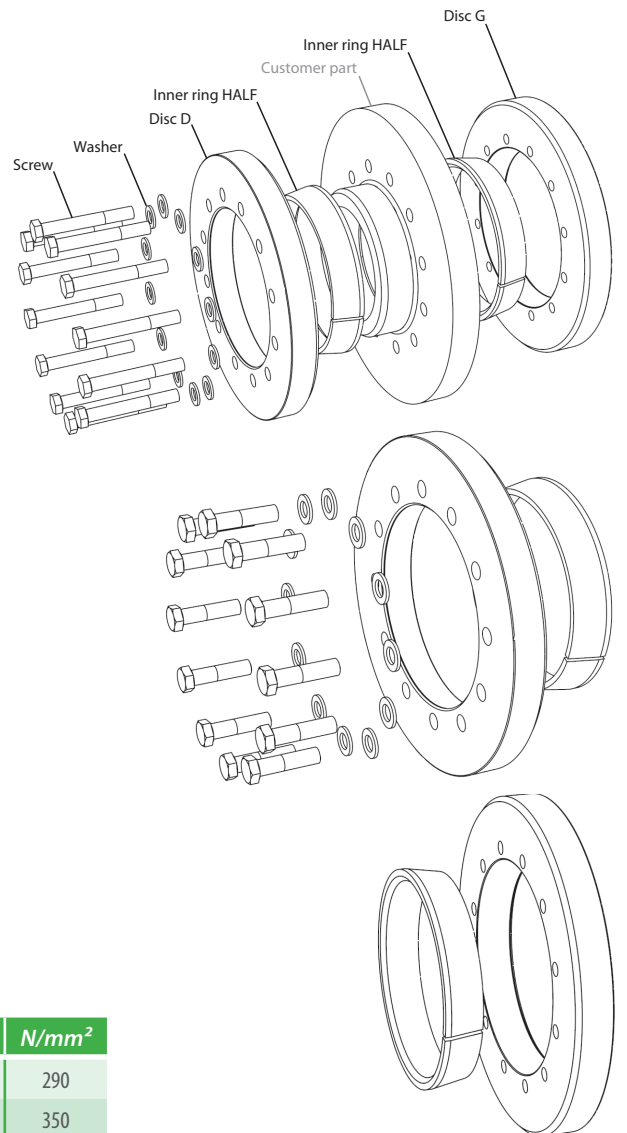

Design of the shrink disc

- $d < 115$ - Discs galvanized - without washers
- $d \geq 115$ - Discs painted - with washers

Dimensions **H** & **e** in unlocked position

Deviation from the standard shaft diameter d_w
see the table „3071 Standard-Range“
and „Calculation of transmissible torques and forces“

Hexagon head bolts are used as standard.
Upon request we provide all sized shrink discs with hexagon socket head bolts (Inbus). (See ordering information)

For **Typ** in ordering information:
GET means **SPLIT**
HALB means **HALF**

min. yield strength $R_{p0.2}$	N/mm ²
Solid shaft	290
Hub	350

Ordering information: **TAS 3071Type - d - y** (e.g.: TAS 3071GET-200-Y60 or TAS 3071HALB-G-200-Y30 or TAS 3071HALB-D-200)

with Inbus: **TAS 3071Type - d - y - Inbus** (e.g.: TAS 3071GET-200-Y60-Inbus etc.)

(Further sizes on request)

3071 HALF / SPLIT Standard-Range

Please note:

All values refer to shrink disk design **HALF!**

Please provide us the dimension of „y“ or the length of screws. Otherwise we can not provide appropriate screws!
(see ordering information)

Applies to shrink disc design **HALF-G:**

- The required screw length is: $Screw\ length\ (3071\ Standard-Range) - l_1 + 2 a + y$ (rounded up to standard lengths)

Applies to shrink disc design **SPLIT:**

- The design consists of 1x **HALF-D** + 1x **HALF-G**
- Delivery is possible with or without screws
- Maximum transmittable torque: $M_{ges} = 2 M_{max}$
- The required screw length: $Screw\ length\ (3071\ Standard-Range) + 2 a + y$ (rounded up to standard lengths)

d mm	d _w mm	M _{max} Nm	D mm	l mm	a mm	l ₁ mm	A mm	B mm	M _A Nm	Z Stk	HALF-D only				n _{max} min ⁻¹	p _N N/mm ²	I kgm ²	Weight kg
											d _B mm	S	DIN	Class				
14	11	14	37	6	0,8	7,5	24	15	3	3	4,5	M 4 x 12	933	10.9	15400	257	0,0000078	0,04
16	13	39	41	7,5	0,8	9	27	17	6	3	5,5	M 5 x 14	933	10.9	13900	282	0,0000121	0,05
18	15	59	43	7,5	0,8	9	29	19	4,8	4	5,5	M 5 x 14	933	8.8	13300	285	0,0000163	0,06
20	17	110	48	8,5	1,5	11,25	34	24	6	5	5,5	M 5 x 18	933	10.9	11900	322	0,0000304	0,09
21	18	120	48	8,5	1,5	11,25	34	24	6	5	5,5	M 5 x 18	933	10.9	11900	307	0,0000309	0,09
22	19	120	48	8,5	1,5	11,25	36	26	6	5	5,5	M 5 x 18	933	10.9	11900	293	0,0000314	0,09
24	20	150	50	9	1,5	11,5	36	26	6	6	5,5	M 5 x 18	933	10.9	11400	322	0,0000366	0,09
30	25	180	60	10	2	12,75	44	32	6	6	5,5	M 5 x 18	931	10.9	9500	225	0,0000844	0,15
36	30	320	72	11	2	13,75	52	38	12	5	6,6	M 6 x 20	933	10.9	7900	231	0,0001944	0,24
38	31	450	80	12	2	15	56	41	12	7	6,6	M 6 x 22	933	10.9	7100	275	0,0003334	0,34
40	32	370	75	11,5	2	14,25	57	43	12	6	6,6	M 6 x 20	933	10.9	7600	236	0,0002438	0,27
41	33	470	80	12	2	14,75	61	46	12	7	6,6	M 6 x 22	933	10.9	7100	255	0,0003232	0,32
44	35	480	80	12	2	14,75	61	47	12	7	6,6	M 6 x 22	933	10.9	7100	238	0,0003126	0,30
50	40	640	90	13	2	16	70	53	12	8	6,6	M 6 x 25	933	10.9	6300	217	0,0005432	0,41
55	45	750	100	14	2,5	17,75	75	58	12	8	6,6	M 6 x 25	933	10.9	5700	189	0,0009118	0,56
62	50	1000	110	14	2,5	17,75	86	66	12	10	6,6	M 6 x 25	933	10.9	5200	210	0,0013154	0,66
68	55	1100	115	14	2,5	17,75	86	72	12	10	6,6	M 6 x 25	933	10.9	4900	191	0,0015395	0,69
75	60	1800	138	16,5	3	20,25	100	79	30	7	9	M 8 x 30	933	10.9	4100	233	0,0037004	1,2
80	65	2000	145	16,5	3	20,25	100	84	30	7	9	M 8 x 30	933	10.9	3900	218	0,0044566	1,3
90	70	3000	155	20	4	24,5	114	94	30	10	9	M 8 x 35	931	10.9	3600	231	0,0068266	1,7
100	75	3600	170	22	4	27	124	104	30	12	9	M 8 x 35	931	10.9	3300	220	0,0106975	2,2
110	80	4400	185	24,5	4	30	136	114	59	9	11	M 10 x 40	931	10.9	3000	208	0,0173719	3,0
115	80	4600	200	25	4	30	150	124	59	10	11	M 10 x 40	931	10.9	2800	215	0,0239512	3,6
120	85	4800	200	25	4	30	150	124	59	10	11	M 10 x 40	931	10.9	2800	206	0,0238000	3,5
125	90	6500	215	26	5	32	160	134	59	12	11	M 10 x 45	931	10.9	2600	226	0,0332444	4,3
140	100	8900	230	28	5	35,25	175	146	100	10	13,5	M 12 x 50	931	10.9	2400	224	0,0480312	5,3
155	110	11900	265	30	5	37,25	192	165	100	12	13,5	M 12 x 50	931	10.9	2100	224	0,0942500	8,0
165	120	19300	290	33	5	40,5	210	175	250	8	17,5	M 16 x 55	931	10.9	1900	258	0,1530719	11
175	130	21300	300	33	5	40,5	220	185	250	8	17,5	M 16 x 55	931	10.9	1900	243	0,1658594	11
185	140	29500	330	40,5	5	48	236	195	250	10	17,5	M 16 x 70	931	10.9	1700	227	0,3220312	18

3071 HALF / SPLIT Standard-Range

d mm	d _w mm	M _{max} Nm	D mm	l mm	a mm	l ₁ mm	A mm	B mm	M _A Nm	Z Stk	HALF-D only				n _{max} min ⁻¹	p _N N/mm ²	I kgm ²	Weight kg
											d _B mm	S	DIN	Class				
195	150	39700	350	40,5	5	48	246	210	250	12	17,5	M 16 x 70	931	10.9	1600	258	0,4013125	20
200	155	40800	350	40,5	5	48	246	210	250	12	17,5	M 16 x 70	931	10.9	1600	252	0,3859375	19
220	165	51800	370	52	8	60	270	230	250	15	17,5	M 16 x 80	931	10.9	1500	231	0,6022250	26
240	180	72400	405	54	8	62,5	295	248	490	12	22	M 20 x 90	931	10.9	1400	254	0,8865000	32
245	185	73900	410	55,5	8	63,5	298	251	490	12	22	M 20 x 90	931	10.9	1300	241	0,9410156	33
260	190	85300	440	59,5	8	68	321	268	490	14	22	M 20 x 90	931	10.9	1300	244	1,3713	42
280	210	112000	460	67	10	77	346	288	490	16	22	M 20 x 100	931	10.9	1200	234	1,7762	49
300	230	143000	485	71	10	81	364	308	490	18	22	M 20 x 100	931	10.9	1100	230	2,3172	57
320	240	163000	520	71	10	81	386	328	490	20	22	M 20 x 100	931	10.9	1100	239	3,0756	66
340	250	163000	570	77	10	88	408	348	490	20	22	M 20 x 110	931	10.9	1000	205	5,0658	92
350	270	228000	580	80	10	91	432	358	490	24	22	M 20 x 110	931	10.9	980	229	5,5068	96
360	290	259000	590	80	10	91	432	368	490	24	22	M 20 x 110	931	10.9	970	222	5,8518	98
380	300	317000	645	85	13	97	458	387	840	20	26	M 24 x 120	931	10.9	880	245	8,8967	127
390	310	348000	660	85	13	97	468	397	840	21	26	M 24 x 120	931	10.9	860	251	9,7705	133
400	320	361000	680	85	13	97	480	407	840	21	26	M 24 x 120	931	10.9	840	245	11,05	142
420	340	445000	690	95	13	107	504	427	840	24	26	M 24 x 130	931	10.9	830	234	12,97	159
440	350	445000	750	101,5	13	114	527	447	840	24	26	M 24 x 140	931	10.9	760	207	19,56	207
460	370	478000	770	101,5	13	114	547	468	840	24	26	M 24 x 140	931	10.9	740	198	21,52	214
480	390	599000	800	109	15	121,5	570	488	840	28	26	M 24 x 150	931	10.9	710	208	26,44	243
500	410	715000	850	109	15	121,5	590	508	1250	24	30	M 27 x 150	931	10.9	670	225	34,04	280
530	440	980000	900	122,5	15	135	620	538	1250	30	30	M 27 x 170	931	10.9	630	232	46,77	343
560	460	1082000	950	122,5	15	135	650	568	1250	32	30	M 27 x 170	931	10.9	600	234	58,07	382
590	480	1257000	980	132,5	15	147,5	685	600	1250	36	30	M 27 x 180	931	10.9	580	229	71,15	435
620	510	1428000	1020	132,5	15	147,5	715	630	1250	38	30	M 27 x 180	931	10.9	560	230	82,99	466
660	540	1838000	1100	145	15	160	760	670	1700	38	33	M 30 x 200	931	10.9	520	238	123	598
700	580	2116000	1200	145	15	160	800	710	1700	40	33	M 30 x 200	931	10.9	470	236	177	733
720	600	2319000	1230	145	15	160	820	730	1700	42	33	M 30 x 200	931	10.9	460	241	195	767
750	620	2483000	1230	155	15	172,5	855	762	1700	44	33	M 30 x 220	931	10.9	460	225	210	810
800	660	2750000	1310	155	15	172,5	905	812	1700	46	33	M 30 x 220	931	10.9	430	220	270	917
850	700	3161000	1330	170	15	187,5	965	862	1700	50	33	M 30 x 230	931	10.9	430	204	302	969
900	740	3475000	1400	170	15	187,5	1015	912	1700	52	33	M 30 x 230	931	10.9	400	200	369	1065
950	780	4210000	1550	185	15	205	1075	962	2800	42	39	M 36 x 250	931	10.9	370	199	643	1556
1000	820	5281000	1620	185	15	205	1125	1012	2800	50	39	M 36 x 250	931	10.9	350	225	763	1685

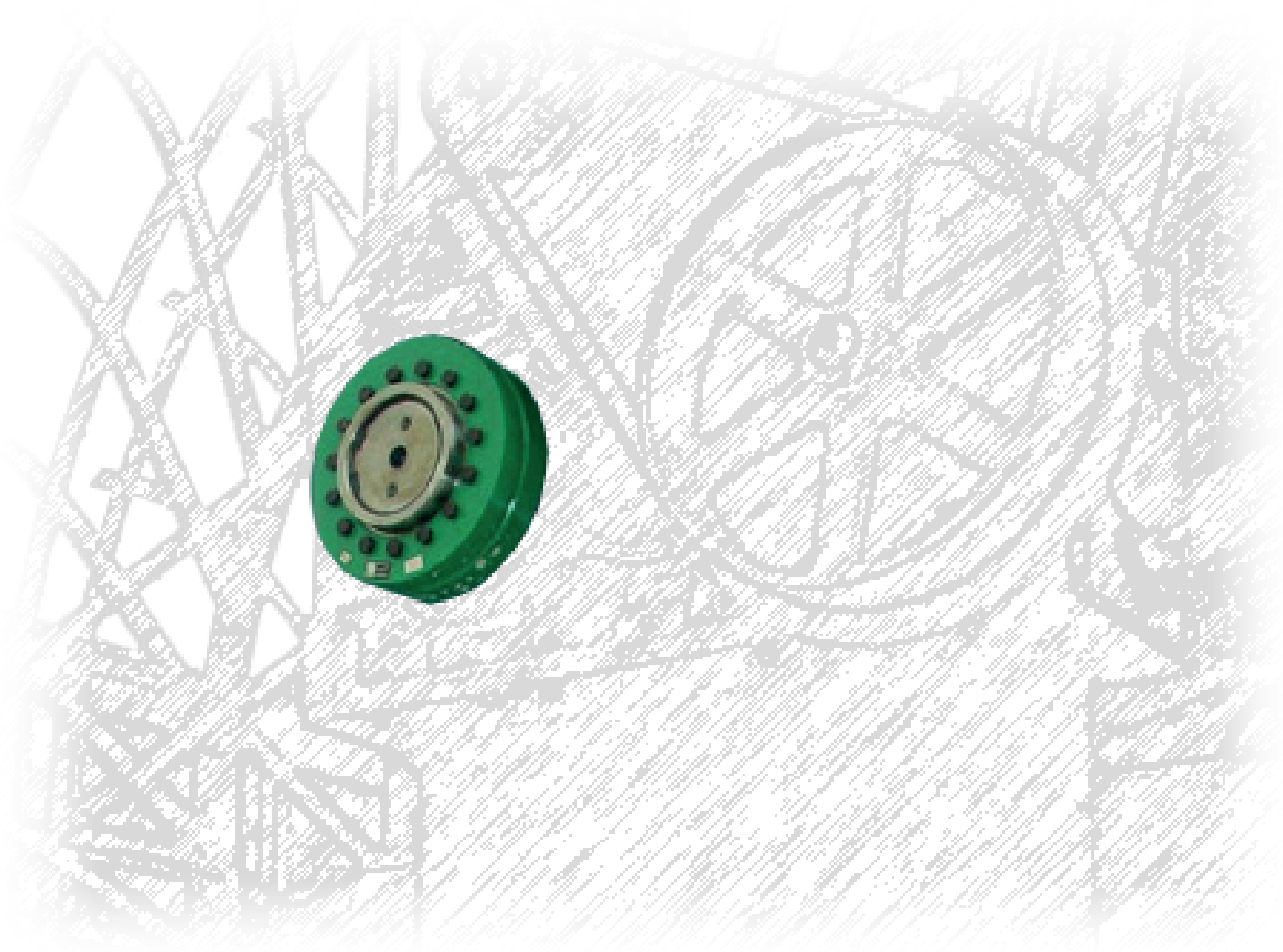

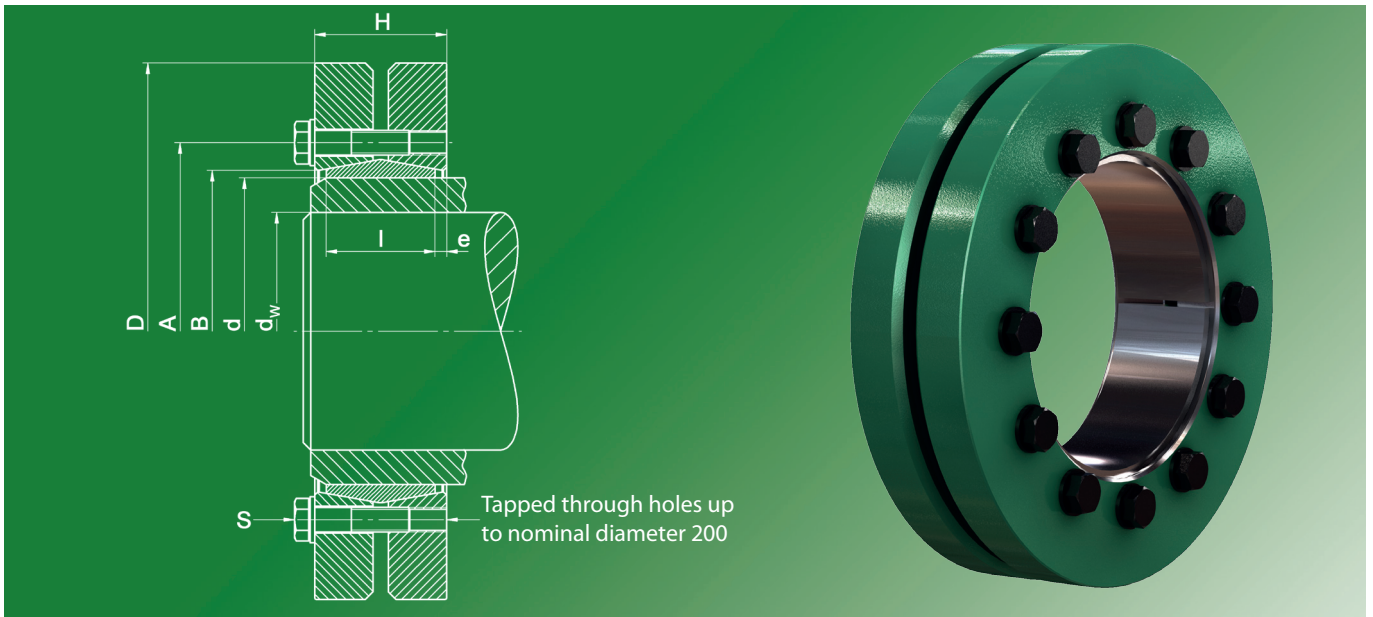

Used symbols

d	[mm]	Nominal diameter of the shrink disc
d_w	[mm]	Shaft diameter
M_{max}	[mm]	Maximal transmittable torque
D	[mm]	Outer diameter
l	[mm]	Length of the inner ring
e	[mm]	Excess length
H	[mm]	Width of the shrink disc
A	[mm]	Pitch circle diameter
B	[mm]	Attachment size
M_A	[Nm]	Tightening torque of the clamping screws
Z		Number of clamping screws
S		Size of the clamping screws
n_{max}	[min ⁻¹]	Permitted rotational frequency
p_N	[N/mm ²]	Moderate pressure to the hub
I	[kgm ²]	Moment of inertia

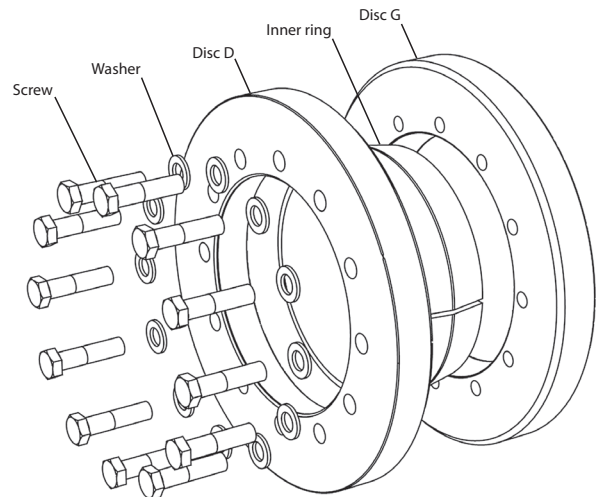

Design of the shrink disc

$d < 115$ - Discs galvanized - without washers

$d \geq 115$ - Discs painted - with washers

Dimensions **H** & **e** in unlocked position

Hexagon head bolts are used as standard.

Upon request we provide all sized shrink discs with hexagon socket head bolts (Inbus). (See ordering information)

Variation from the standard shaft diameter d_w

> mm	≤ mm	minimal - mm	maximal + mm
10	30	-1	1
30	50	-3	2
50	140	-5	5
140	180	-10	5
180	320	-15	10
320	500	-20	10
500	700	-30	20
700	820	-40	20

min. yield strength $R_{p0,2}$	N/mm ²
Solid shaft	350
Hub	450

$$M = M_{max(Katalog)} \frac{d_w(soll)}{d_w(Katalog)}$$

(see Basics - Calculation)

Ordering information: TAS 3081 - d (e.g.: TAS 3081-200 ... further sizes on request)
with Inbus: TAS 3081 - d - Inbus (e.g.: TAS 3081-200-Inbus)

3081

Standard-Range strengthened

<i>d</i> mm	<i>d_w</i> mm	<i>M_{max}</i> Nm	<i>D</i> mm	<i>l</i> mm	<i>e</i> mm	<i>H</i> mm	<i>A</i> mm	<i>B</i> mm	<i>M_A</i> Nm	<i>Z</i> Stk	<i>S</i>	<i>DIN</i>	<i>Class</i>	<i>n_{max}</i> min ⁻¹	<i>p_N</i> N/mm ²	<i>I</i> kgm ²	<i>Weight</i> kg
14	11	48	37	9	1,5	12	24	15	4	3	M 4 x 10	933	12.9	15400	344	0,000137	0,07
30	25	520	60	16	2,75	21,5	44	32	8	6	M 5 x 18	931	12.9	9500	300	0,001687	0,30
36	30	780	72	18	2,75	23,5	52	38	14	5	M 6 x 20	933	12.9	7900	271	0,0003888	0,48
38	31	1100	80	20	3	26	56	41	14	7	M 6 x 25	933	12.9	7100	324	0,0006569	0,67
40	32	910	75	19	2,75	24,5	57	43	14	6	M 6 x 20	933	12.9	7600	277	0,0004967	0,55
50	40	1500	90	22	3	28	70	53	14	8	M 6 x 25	933	12.9	6300	255	0,0010998	0,83
55	45	1800	100	23	3,75	30,5	75	58	14	8	M 6 x 25	933	12.9	5700	222	0,0017909	1,1
62	50	2600	110	23	3,75	30,5	86	66	14	10	M 6 x 25	933	12.9	5200	246	0,0025909	1,3
68	55	2700	115	23	3,75	30,5	86	72	14	10	M 6 x 25	933	12.9	4900	225	0,0031236	1,4
75	60	4400	138	25	3,75	32,5	100	79	35	7	M 8 x 30	933	12.9	4100	272	0,0070923	2,3
80	65	4900	145	25	3,75	32,5	100	84	35	7	M 8 x 30	933	12.9	3900	255	0,0085703	2,5
90	70	7200	155	30	4,5	39	114	94	35	10	M 8 x 35	931	12.9	3600	269	0,0132516	3,3
100	75	8800	170	34	5	44	124	104	35	12	M 8 x 35	931	12.9	3300	257	0,0213950	4,4
110	80	10800	185	39	5,5	50	136	114	69	9	M 10 x 40	931	12.9	3000	243	0,0347437	6,0
115	80	11400	200	40	5	50	150	124	69	10	M 10 x 40	931	12.9	2800	252	0,0485678	7,3
120	85	11700	200	40	5	50	150	124	69	10	M 10 x 40	931	12.9	2800	241	0,0476000	7,0
125	90	15900	215	42	6	54	160	134	69	12	M 10 x 40	931	12.9	2600	265	0,0672619	8,7
140	100	21700	230	46	7,25	60,5	175	146	120	10	M 12 x 45	931	12.9	2400	263	0,0996875	11
155	110	28900	265	50	7,25	64,5	192	165	120	12	M 12 x 50	931	12.9	2100	262	0,1885000	16
165	120	46400	290	56	7,5	71	210	175	290	8	M 16 x 55	931	12.9	1900	303	0,3061438	22
175	130	51200	300	56	7,5	71	220	185	290	8	M 16 x 55	931	12.9	1900	286	0,3467969	23
185	140	70700	330	71	7,5	86	236	195	290	10	M 16 x 70	931	12.9	1700	266	0,6261719	35
195	150	94900	350	71	7,5	86	246	210	290	12	M 16 x 70	931	12.9	1600	303	0,8026250	40
200	155	97700	350	71	7,5	86	246	210	290	12	M 16 x 70	931	12.9	1600	296	0,7921875	39
220	165	124000	370	88	8	104	270	230	290	15	M 16 x 80	931	12.9	1500	271	1,1813	51
240	180	171000	405	92	8,5	109	295	248	570	12	M 20 x 80	931	12.9	1400	296	1,7730	64
245	185	175000	410	95	8	111	298	251	570	12	M 20 x 80	931	12.9	1300	281	1,9105	67
260	190	203000	440	103	8,5	120	321	268	570	14	M 20 x 90	931	12.9	1300	285	2,7426	84
280	210	266000	460	114	10	134	346	288	570	16	M 20 x 100	931	12.9	1200	273	3,5888	99
300	230	340000	485	122	10	142	364	308	570	18	M 20 x 100	931	12.9	1100	268	4,6751	115
320	240	386000	520	122	10	142	386	328	570	20	M 20 x 100	931	12.9	1100	279	6,1978	133
340	250	474000	570	134	11	156	408	348	570	24	M 20 x 110	931	12.9	1000	287	10,08	183
350	270	539000	580	140	11	162	432	358	570	24	M 20 x 110	931	12.9	980	267	11,07	193
360	290	613000	590	140	11	162	432	368	570	24	M 20 x 110	931	12.9	970	259	11,76	197
380	300	750000	645	144	12	168	458	387	980	20	M 24 x 120	931	12.9	880	287	17,86	255
390	310	824000	660	144	12	168	468	397	980	21	M 24 x 120	931	12.9	860	294	19,54	266
400	320	853000	680	144	12	168	480	407	980	21	M 24 x 120	931	12.9	840	286	22,10	284
420	340	1052000	690	164	12	188	504	427	980	24	M 24 x 130	931	12.9	830	274	25,94	318
440	350	1054000	750	177	12,5	202	527	447	980	24	M 24 x 140	931	12.9	760	242	39,13	414
460	370	1331000	770	177	12,5	202	547	468	980	28	M 24 x 140	931	12.9	740	270	43,04	428
480	390	1523000	800	188	12,5	213	570	488	980	30	M 24 x 140	931	12.9	710	261	52,77	485
500	410	1691000	850	188	12,5	213	590	508	1450	24	M 27 x 150	931	12.9	670	263	68,08	560
530	440	2314000	900	215	12,5	240	620	538	1450	30	M 27 x 180	931	12.9	630	272	93,54	686
560	460	2554000	950	215	12,5	240	650	568	1450	32	M 27 x 180	931	12.9	600	274	116	763
590	480	2967000	980	235	15	265	685	600	1450	36	M 27 x 180	931	12.9	580	268	142	869
620	510	3370000	1020	235	15	265	715	630	1450	38	M 27 x 180	931	12.9	560	269	166	931

3081

Standard-Range strengthened

<i>d</i> mm	<i>d_w</i> mm	<i>M_{max}</i> Nm	<i>D</i> mm	<i>l</i> mm	<i>e</i> mm	<i>H</i> mm	<i>A</i> mm	<i>B</i> mm	<i>M_A</i> Nm	<i>Z</i> Stk	<i>S</i>	<i>DIN</i>	<i>Class</i>	<i>n_{max}</i> min ⁻¹	<i>p_N</i> N/mm ²	<i>I</i> kgm ²	<i>Weight</i> kg
660	540	4329000	1100	260	15	290	760	670	1950	38	M 30 x 200	931	12.9	520	278	246	1195
700	580	4980000	1200	260	15	290	800	710	1950	40	M 30 x 200	931	12.9	470	276	354	1466
720	600	5456000	1230	260	15	290	820	730	1950	42	M 30 x 200	931	12.9	460	282	390	1535
750	620	5844000	1230	280	17,5	315	855	762	1950	44	M 30 x 220	931	12.9	460	263	420	1619
800	660	6475000	1310	280	17,5	315	905	812	1950	46	M 30 x 220	931	12.9	430	258	540	1833
850	700	7443000	1330	310	17,5	345	965	862	1950	50	M 30 x 250	931	12.9	430	238	604	1938
900	740	8180000	1400	310	17,5	345	1015	912	1950	52	M 30 x 250	931	12.9	400	234	738	2130
950	780	10005000	1550	340	20	380	1075	962	3300	42	M 36 x 260	931	12.9	370	234	1285	3111
1000	820	12541000	1620	340	20	380	1125	1012	3300	50	M 36 x 260	931	12.9	350	265	1526	3369

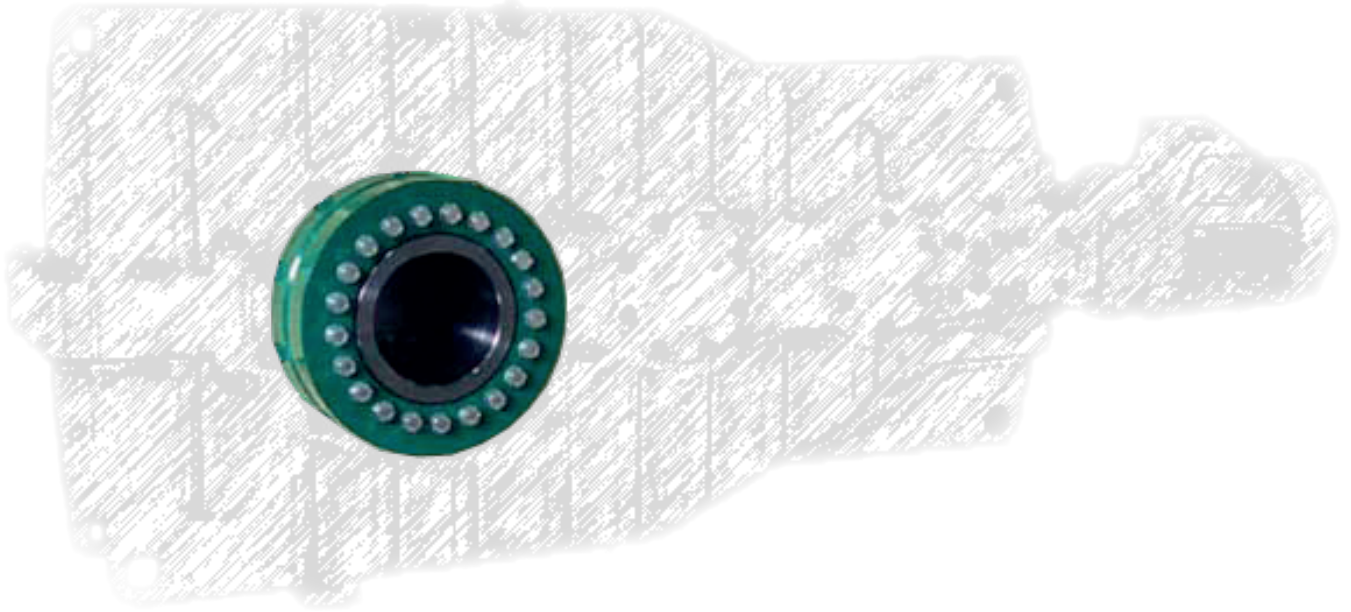

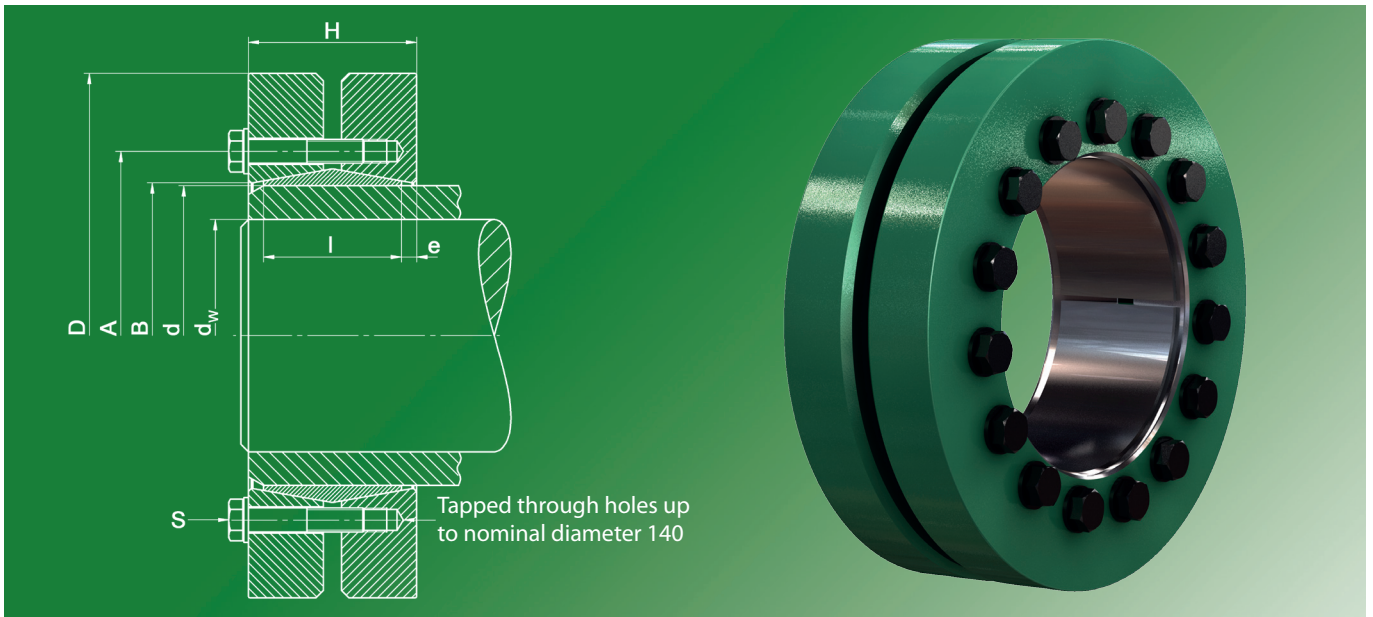

Used symbols

d	[mm]	Nominal diameter of the shrink disc
d_w	[mm]	Shaft diameter
M_{max}	[mm]	Maximal transmittable torque
D	[mm]	Outer diameter
l	[mm]	Length of the inner ring
e	[mm]	Excess length
H	[mm]	Width of the shrink disc
A	[mm]	Pitch circle diameter
B	[mm]	Attachment size
M_A	[Nm]	Tightening torque of the clamping screws
Z		Number of clamping screws
S		Size of the clamping screws
n_{max}	[min ⁻¹]	Permitted rotational frequency
p_N	[N/mm ²]	Moderate pressure to the hub
I	[kgm ²]	Moment of inertia

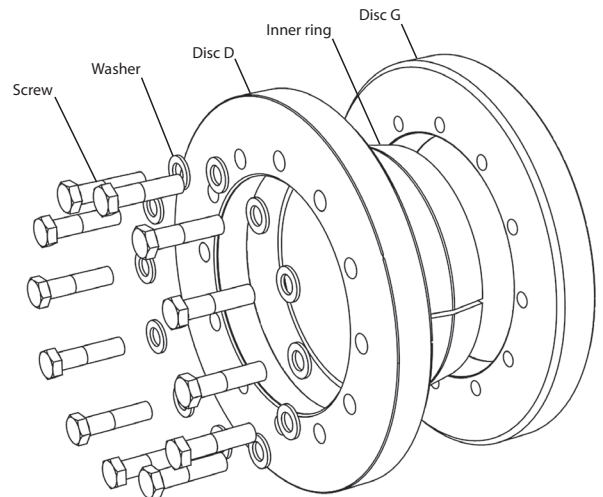

Design of the shrink disc

$d < 120$ - Discs galvanized - without washers

$d \geq 120$ - Discs painted - with washers

Dimensions **H** & **e** in unlocked position

Hexagon head bolts are used as standard.

Upon request we provide all sized shrink discs with hexagon socket head bolts (Inbus). (See ordering information)

Variation from the standard shaft diameter d_w

> mm	≤ mm	minimal - mm	maximal + mm
40	50	-3	2
50	140	-5	5
140	180	-10	5
180	320	-15	10
320	440	-20	10
440	600	-30	10

$$M = M_{max (Katalog)} \frac{d_w (soll)}{d_w (Katalog)}$$

(see Basics - Calculation)

min. yield strength $R_{p0,2}$	N/mm ²
Solid shaft	290
Hub	350

Ordering information: TAS 3091 - d (e.g.: TAS 3091-200 ... further sizes on request)
with Inbus: TAS 3091 - d - Inbus (e.g.: TAS 3091-200-Inbus)

3091 Heavy-Range

d mm	d_w mm	M_{max} Nm	D mm	l mm	e mm	H mm	A mm	B mm	M_A Nm	Z Stk	S	DIN	Class	n_{max} min ⁻¹	p_N N/mm ²	I kgm ²	Weight kg
40	30	890	80	25	3,5	32	62	43	30	4	M 8 x 30	933	10.9	7100	249	0,0008300	0,83
44	34	1300	85	28	3	34	66	47	30	5	M 8 x 30	933	10.9	6700	253	0,0011451	1,0
50	40	2500	95	30	4,5	39	73	54	30	7	M 8 x 35	933	10.9	6000	291	0,0020169	1,4
55	45	2900	105	30	4,5	39	78	59	30	7	M 8 x 35	933	10.9	5400	264	0,0029856	1,7
62	50	3200	115	30	4,5	39	85	66	30	7	M 8 x 35	933	10.9	4900	235	0,0042672	2,0
68	55	3900	120	30	4,5	39	92	72	30	8	M 8 x 35	933	10.9	4700	244	0,0049938	2,1
75	60	5900	145	36	5	46	105	84	59	7	M 10 x 40	933	10.9	4100	257	0,0101760	3,3
80	65	6600	145	36	5	46	105	84	59	7	M 10 x 40	933	10.9	3900	241	0,0123412	3,6
90	70	7600	160	40	5	50	116	94	59	8	M 10 x 40	933	10.9	3500	220	0,0202200	4,8
100	75	9800	170	44	5	54	126	104	59	10	M 10 x 45	931	10.9	3300	225	0,0262575	5,4
110	80	12000	185	50	5	60	138	114	59	12	M 10 x 45	931	10.9	3000	216	0,0411134	7,1
120	85	14300	210	55	5	65	155	125	100	10	M 12 x 50	931	10.9	2700	219	0,0731250	10
125	90	15600	215	55	5	65	160	129	100	10	M 12 x 50	931	10.9	2600	210	0,0850438	11
140	100	21000	230	60	7	74	175	144	100	12	M 12 x 55	931	10.9	2400	207	0,1178125	13
155	110	29500	265	66	7	80	198	164	100	15	M 12 x 60	931	10.9	2100	212	0,2356250	20
165	120	48100	290	72	8	88	210	174	250	10	M 16 x 70	931	10.9	1900	251	0,3757219	27
175	130	53100	300	72	8	88	220	184	250	10	M 16 x 70	931	10.9	1900	237	0,4221875	28
185	140	83500	330	92	10	112	236	194	250	14	M 16 x 80	931	10.9	1700	245	0,8229688	46
200	150	95400	350	92	10	112	246	204	250	15	M 16 x 80	931	10.9	1600	243	1,0359000	51
220	165	138000	370	114	10	134	270	224	250	20	M 16 x 90	931	10.9	1500	238	1,5287	66
240	180	180000	405	120	12	144	295	244	490	15	M 20 x 100	931	10.9	1400	243	2,3548	85
260	200	247000	430	136	12	160	321	265	490	18	M 20 x 110	931	10.9	1300	238	3,2825	104
280	220	330000	460	148	12	172	346	285	490	21	M 20 x 120	931	10.9	1200	237	4,6400	128
300	240	388000	485	152	12	176	364	305	490	22	M 20 x 120	931	10.9	1100	225	5,8134	143
320	250	428000	520	160	12	184	386	325	490	24	M 20 x 130	931	10.9	1100	219	7,9220	170
340	260	546000	570	176	12	200	420	345	840	21	M 24 x 130	931	10.9	1000	236	13,10	238
350	280	626000	580	176	12	200	425	355	840	21	M 24 x 130	931	10.9	980	229	13,94	243
360	290	687000	590	180	12	204	432	365	840	22	M 24 x 140	931	10.9	970	228	14,81	248
380	305	719000	645	180	12	204	458	387	840	22	M 24 x 140	931	10.9	880	216	21,65	309
390	310	789000	660	188	12	212	468	397	840	24	M 24 x 140	931	10.9	860	220	24,68	336
400	320	817000	680	188	12	212	480	407	840	24	M 24 x 140	931	10.9	840	214	27,85	358
420	340	1110000	690	214	12	238	504	427	840	30	M 24 x 150	931	10.9	830	224	33,52	411
440	350	1173000	750	224	14	252	527	448	1250	24	M 27 x 170	931	10.9	760	215	49,52	524
460	370	1483000	770	224	14	252	547	468	1250	28	M 27 x 170	931	10.9	740	240	54,40	541
480	390	1694000	800	246	14	274	580	488	1250	30	M 27 x 180	931	10.9	710	224	70,39	647
500	410	1910000	850	246	14	274	600	508	1250	32	M 27 x 180	931	10.9	670	229	90,81	747
530	440	2207000	910	275	14	303	630	538	1250	34	M 27 x 200	931	10.9	630	206	130	939
660	540	4116000	1070	310	15	340	780	670	2800	30	M 36 x 240	931	10.9	530	224	263	1331

3091 HALF / SPLIT Heavy-Range

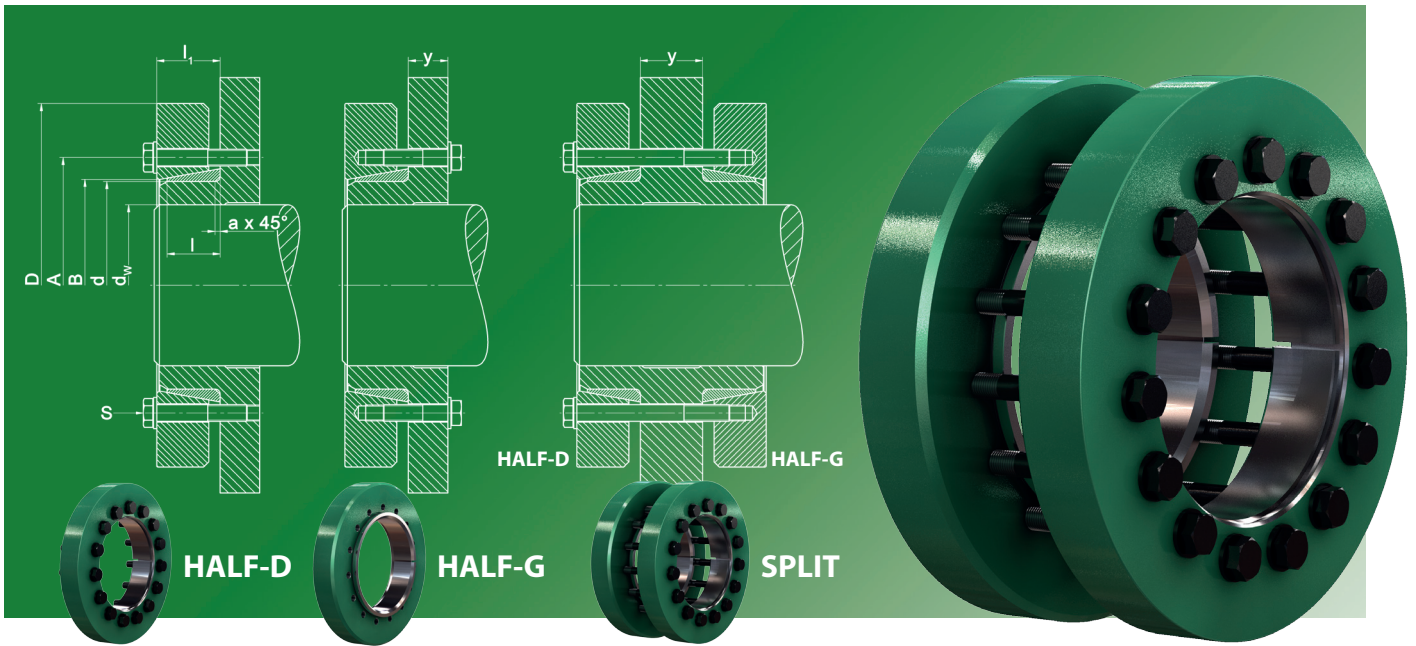

Used symbols

d	[mm]	Nominal diameter of the shrink disc
d_w	[mm]	Shaft diameter
M_{max}	[mm]	Maximal transmittable torque
D	[mm]	Outer diameter
l	[mm]	Length of the inner ring
a	[mm]	Width of the chamfer on the inner ring
l_1	[mm]	Width of the shrink disc
A	[mm]	Pitch circle diameter
B	[mm]	Attachment size
M_A	[Nm]	Tightening torque of the clamping screws
Z		Number of clamping screws
S		Size of the clamping screws
n_{max}	[min ⁻¹]	Permitted rotational frequency
p_N	[N/mm ²]	Moderate pressure to the hub
I	[kgm ²]	Moment of inertia

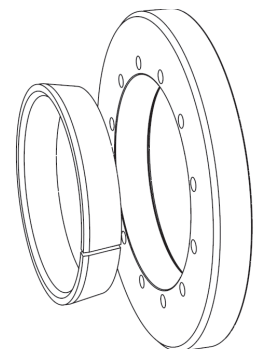
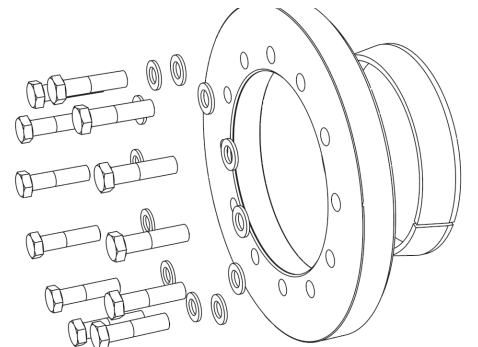
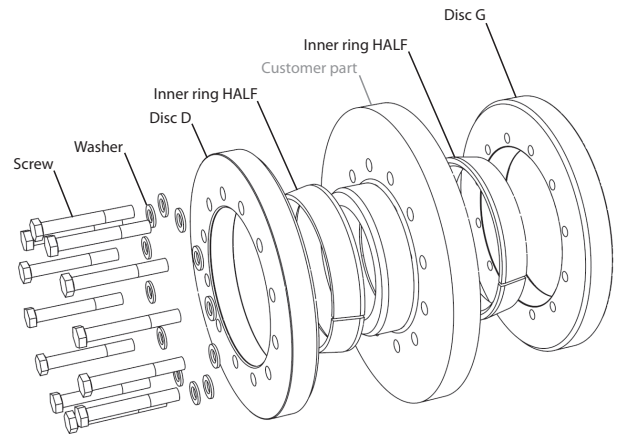

Design of the shrink disc

$d < 120$ - Discs galvanized - without washers

$d \geq 120$ - Discs painted - with washers

Dimensions **H** & **e** in unlocked position

Deviation from the standard shaft diameter d_w
see the table „3091 Standard-Range“
and „Calculation of transmissible torques and forces“

Hexagon head bolts are used as standard.
Upon request we provide all sized shrink discs with hexagon socket head bolts (Inbus). (See ordering information)

For **Typ** in ordering information:
GET means **SPLIT**
HALB means **HALF**

min. yield strength $R_{p0.2}$	N/mm ²
Solid shaft	290
Hub	350

Ordering information: TAS 3091Type - d - y (e.g.: TAS 3091GET-200-Y60 or TAS 3091HALB-G-200-Y30 or TAS 3091HALB-D-200)

with Inbus: TAS 3091Type - d - y - Inbus (e.g.: TAS 3091GET-200-Y60-Inbus etc.)

(Further sizes on request)

3091 HALF / SPLIT Heavy-Range

Please note:

All values refer to shrink disk design **HALF!**

Please provide us the dimension of „y“ or the length of screws. Otherwise we can not provide appropriate screws!
(see ordering information)

Applies to shrink disc design **HALF-G:**

- The required screw length is: $\text{Screw length (3091 Heavy-Range)} - l_1 + 2 a + y$ (rounded up to standard lengths)

Applies to shrink disc design **SPLIT:**

- The design consists of 1x **HALF-D** + 1x **HALF-G**
- Delivery is possible with or without screws
- Maximum transmittable torque: $M_{ges} = 2 M_{max}$
- The required screw length: $\text{Screw length (3091 Heavy-Range)} + 2 a + y$ (rounded up to standard lengths)

d mm	d _w mm	M _{max} Nm	D mm	l mm	a mm	l ₁ mm	A mm	B mm	M _A Nm	Z Stk	HALF-D only				n _{max} min ⁻¹	p _N N/mm ²	I kgm ²	Weight kg
											d _B mm	S	DIN	Class				
40	30	440	80	14,5	2	18	62	43	30	4	9	M 8 x 30	933	10.9	7100	249	0,0004100	0,41
44	34	670	85	16	2	19	66	47	30	5	9	M 8 x 30	933	10.9	6700	253	0,0005611	0,49
50	40	960	95	17	2	21,5	73	54	24	7	9	M 8 x 35	933	10.9	6000	233	0,0009796	0,68
55	45	1300	105	17,5	2,5	22	78	59	27	7	9	M 8 x 35	933	10.9	5400	238	0,0014752	0,84
62	50	1600	115	17,5	2,5	22	85	66	30	7	9	M 8 x 35	933	10.9	4900	235	0,0021336	1,0
68	55	1900	120	17,5	2,5	22	92	72	30	8	9	M 8 x 35	933	10.9	4700	244	0,0023780	1,0
75	60	2900	145	22	4	27	105	84	59	7	11	M 10 x 40	933	10.9	4100	257	0,0052422	1,7
80	65	3300	145	22	4	27	105	84	59	7	11	M 10 x 40	933	10.9	3900	241	0,0061706	1,8
90	70	3800	160	25	4	30	116	94	59	8	11	M 10 x 40	933	10.9	3500	220	0,0101100	2,4
100	75	4900	170	27	4	32	126	104	59	10	11	M 10 x 45	931	10.9	3300	225	0,0131288	2,7
110	80	6000	185	30	5	35	138	114	59	12	11	M 10 x 45	931	10.9	3000	216	0,0208462	3,6
120	85	7100	210	32,5	5	37,5	155	125	100	10	13,5	M 12 x 50	931	10.9	2700	219	0,0372938	5,1
125	90	7800	215	32,5	5	37,5	160	129	100	10	13,5	M 12 x 50	931	10.9	2600	210	0,0409756	5,3
140	100	10500	230	35	5	42	175	144	100	12	13,5	M 12 x 55	931	10.9	2400	207	0,0598125	6,6
155	110	14700	265	38	5	45	198	164	100	15	13,5	M 12 x 60	931	10.9	2100	212	0,1178125	10
165	120	24000	290	41	5	49	210	174	250	10	17,5	M 16 x 70	931	10.9	1900	251	0,1809031	13
175	130	26500	300	41	5	49	220	184	250	10	17,5	M 16 x 70	931	10.9	1900	237	0,2110938	14
185	140	41700	330	51	5	61	236	194	250	14	17,5	M 16 x 80	931	10.9	1700	245	0,4114844	23
200	150	47700	350	51	5	61	246	204	250	15	17,5	M 16 x 80	931	10.9	1600	243	0,5078125	25
220	165	69300	370	65	8	75	270	224	250	20	17,5	M 16 x 90	931	10.9	1500	238	0,7643625	33
240	180	90100	405	68	8	80	295	244	490	15	22	M 20 x 100	931	10.9	1400	243	1,1912	43
260	200	123000	430	76	8	88	321	265	490	18	22	M 20 x 110	931	10.9	1300	238	1,6412	52
280	220	165000	460	84	10	96	346	285	490	21	22	M 20 x 120	931	10.9	1200	237	2,3200	64
300	240	194000	485	86	10	98	364	305	490	22	22	M 20 x 120	931	10.9	1100	225	2,9270	72
320	250	214000	520	90	10	102	386	325	490	24	22	M 20 x 130	931	10.9	1100	219	3,9610	85
340	260	273000	570	98	10	110	420	345	840	21	26	M 24 x 140	931	10.9	1000	236	6,5524	119
350	280	313000	580	98	10	110	425	355	840	21	26	M 24 x 140	931	10.9	980	229	6,9409	121
360	290	343000	590	100	10	112	432	365	840	22	26	M 24 x 140	931	10.9	970	228	7,4044	124
380	300	345000	645	103	13	115	458	387	840	22	26	M 24 x 140	931	10.9	880	216	10,79	154
390	310	394000	660	107	13	119	468	397	840	24	26	M 24 x 150	931	10.9	860	220	12,34	168

3091 HALF / SPLIT Heavy-Range

<i>d</i> mm	<i>d_w</i> mm	<i>M_{max}</i> Nm	<i>D</i> mm	<i>l</i> mm	<i>a</i> mm	<i>l₁</i> mm	<i>A</i> mm	<i>B</i> mm	<i>M_A</i> Nm	<i>Z</i> Stk	HALF-D only				<i>n_{max}</i> min ⁻¹	<i>p_N</i> N/mm ²	<i>I</i> kgm ²	Weight kg
											<i>d_B</i> mm	<i>S</i>	<i>DIN</i>	<i>Class</i>				
400	320	408000	680	107	13	119	480	407	840	24	26	M 24 x 150	931	10.9	840	214	13,93	179
420	340	555000	690	120	13	132	504	427	840	30	26	M 24 x 160	931	10.9	830	224	16,72	205
440	350	586000	750	125	13	139	527	448	1250	24	30	M 27 x 170	931	10.9	760	215	24,76	262
460	370	741000	770	125	13	139	547	468	1250	28	30	M 27 x 170	931	10.9	740	240	27,25	271
480	390	847000	800	138	15	152	580	488	1250	30	30	M 27 x 180	931	10.9	710	224	35,25	324
500	410	955000	850	138	15	152	600	508	1250	32	30	M 27 x 180	931	10.9	670	229	45,34	373
530	440	1103000	910	152,5	15	166,5	630	538	1250	34	30	M 27 x 200	931	10.9	630	206	65,15	470
660	540	2058000	1070	170	15	185	780	670	2800	30	39	M 36 x 240	931	10.9	530	224	132	666



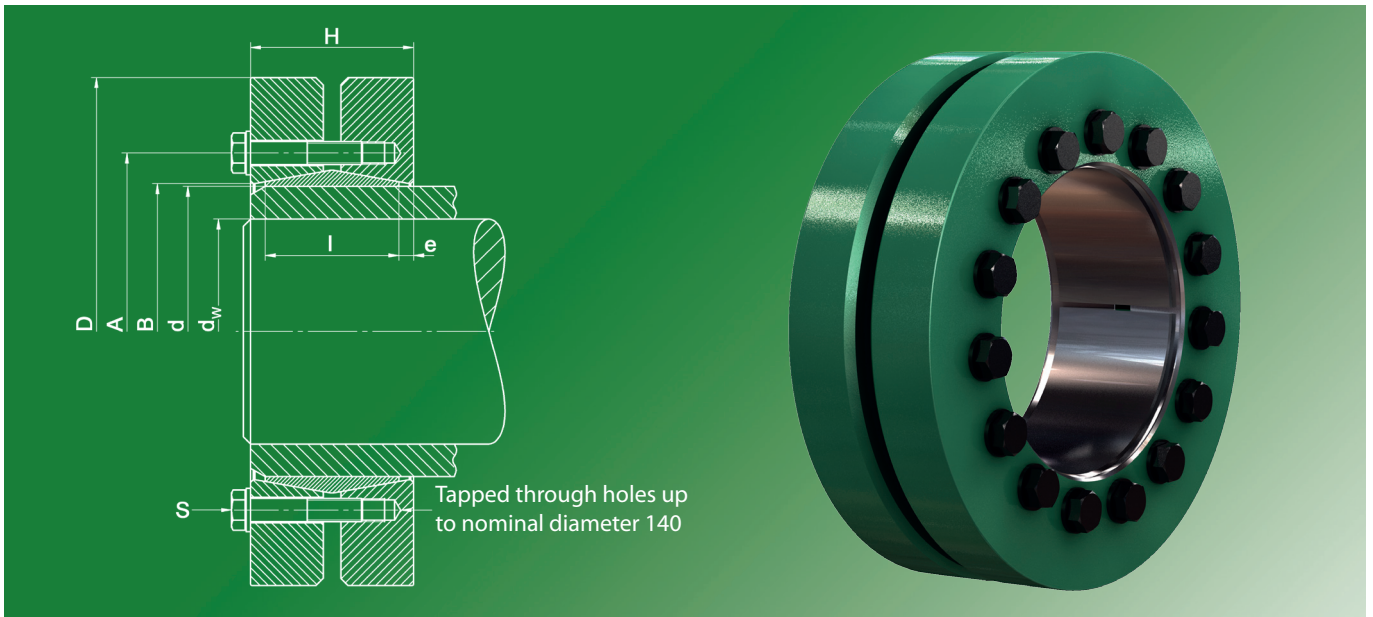

Used symbols

d	[mm]	Nominal diameter of the shrink disc
d_w	[mm]	Shaft diameter
M_{max}	[mm]	Maximal transmittable torque
D	[mm]	Outer diameter
l	[mm]	Length of the inner ring
e	[mm]	Excess length
H	[mm]	Width of the shrink disc
A	[mm]	Pitch circle diameter
B	[mm]	Attachment size
M_A	[Nm]	Tightening torque of the clamping screws
Z		Number of clamping screws
S		Size of the clamping screws
n_{max}	[min ⁻¹]	Permitted rotational frequency
p_N	[N/mm ²]	Moderate pressure to the hub
I	[kgm ²]	Moment of inertia

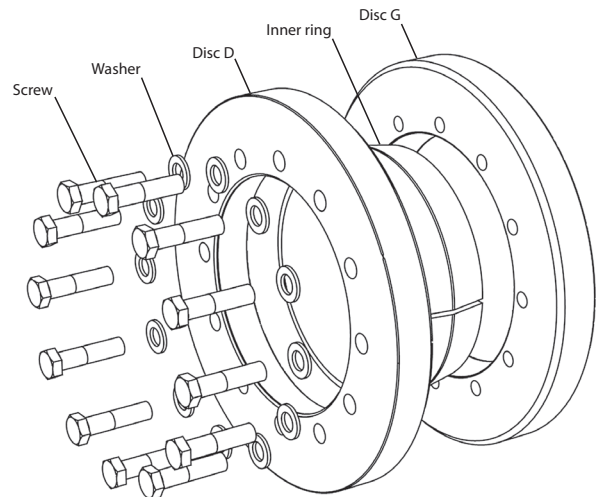

Design of the shrink disc

$d < 120$ - Discs galvanized - without washers

$d \geq 120$ - Discs painted - with washers

Dimensions **H** & **e** in unlocked position

Hexagon head bolts are used as standard.

Upon request we provide all sized shrink discs with hexagon socket head bolts (Inbus). (See ordering information)

Variation from the standard shaft diameter d_w

> mm	≤ mm	minimal - mm	maximal + mm
40	50	-3	2
50	140	-5	5
140	180	-10	5
180	320	-15	10
320	440	-20	10
440	600	-30	10

$$M = M_{max (Katalog)} \frac{d_w (soll)}{d_w (Katalog)}$$

(see Basics - Calculation)

min. yield strength $R_{p0,2}$	N/mm ²
Solid shaft	350
Hub	450

Ordering information: TAS 3093 - d (e.g.: TAS 3093-200 ... further sizes on request)
with Inbus: TAS 3093 - d - Inbus (e.g.: TAS 3093-200-Inbus)

3093 Heavy-Range strengthened

d mm	d _w mm	M _{max} Nm	D mm	l mm	e mm	H mm	A mm	B mm	M _A Nm	Z Stk	S	DIN	Class	n _{max} min ⁻¹	p _N N/mm ²	I kgm ²	Weight kg
40	30	1000	80	25	3,5	32	62	43	35	4	M 8 x 30	933	12.9	7100	291	0,0008300	0,83
44	34	1600	85	28	3	34	66	47	35	5	M 8 x 30	933	12.9	6700	295	0,0011451	1,0
55	45	3500	105	30	4,5	39	78	59	35	7	M 8 x 35	933	12.9	5400	309	0,0029856	1,7
62	50	3800	115	30	4,5	39	85	66	35	7	M 8 x 35	933	12.9	4900	274	0,0042672	2,0
68	55	4700	120	30	4,5	39	92	72	35	8	M 8 x 35	933	12.9	4700	285	0,0049938	2,1
75	60	7200	145	36	5	46	105	84	69	7	M 10 x 40	933	12.9	4100	300	0,0101760	3,3
80	65	8000	145	36	5	46	105	84	69	7	M 10 x 40	933	12.9	3900	282	0,0123412	3,6
90	70	9100	160	40	5	50	116	94	69	8	M 10 x 40	933	12.9	3500	258	0,0202200	4,8
100	75	11800	170	44	5	54	126	104	69	10	M 10 x 45	931	12.9	3300	263	0,0262575	5,4
110	80	14500	185	50	5	60	138	114	69	12	M 10 x 45	931	12.9	3000	253	0,0411134	7,1
120	85	17500	210	55	5	65	155	125	120	10	M 12 x 50	931	12.9	2700	257	0,0731250	10
125	90	19000	215	55	5	65	160	129	120	10	M 12 x 50	931	12.9	2600	246	0,0850438	11
140	100	25600	230	60	7	74	175	144	120	12	M 12 x 55	931	12.9	2400	242	0,1178125	13
155	110	35800	265	66	7	80	198	164	120	15	M 12 x 60	931	12.9	2100	248	0,2356250	20
165	120	57800	290	72	8	88	210	174	290	10	M 16 x 65	931	12.9	1900	295	0,3757219	27
175	130	63800	300	72	8	88	220	184	290	10	M 16 x 65	931	12.9	1900	278	0,4221875	28
185	140	99900	330	92	10	112	236	194	290	14	M 16 x 80	931	12.9	1700	288	0,8229688	46
200	150	114000	350	92	10	112	246	204	290	15	M 16 x 80	931	12.9	1600	285	1,0359	51
220	165	166000	370	114	10	134	270	224	290	20	M 16 x 90	931	12.9	1500	279	1,5287	66
240	180	213000	405	120	12	144	295	244	570	15	M 20 x 100	931	12.9	1400	284	2,3548	85
260	200	294000	430	136	12	160	321	265	570	18	M 20 x 110	931	12.9	1300	277	3,2825	104
280	220	390000	460	148	12	172	346	285	570	21	M 20 x 120	931	12.9	1200	276	4,6400	128
300	240	458000	485	152	12	176	364	305	570	22	M 20 x 120	931	12.9	1100	263	5,8100	143
320	250	506000	520	160	12	184	386	325	570	24	M 20 x 130	931	12.9	1100	255	7,9200	170
340	260	648000	570	176	12	200	420	345	980	21	M 24 x 130	931	12.9	1000	276	13,10	238
350	280	741000	580	176	12	200	425	355	980	21	M 24 x 130	931	12.9	980	268	13,94	243
360	290	812000	590	180	12	204	432	365	980	22	M 24 x 140	931	12.9	970	267	14,81	248
380	305	850000	645	180	12	204	458	387	980	22	M 24 x 140	931	12.9	880	253	21,65	309
390	310	934000	660	188	12	212	468	397	980	24	M 24 x 140	931	12.9	860	257	24,68	336
420	340	1312000	690	214	12	238	504	427	980	30	M 24 x 150	931	12.9	830	262	33,52	411
440	350	1388000	750	224	14	252	527	448	1450	24	M 27 x 170	931	12.9	760	251	49,52	524
460	370	1752000	770	224	14	252	547	468	1450	28	M 27 x 170	931	12.9	740	280	54,40	541
480	390	2001000	800	246	14	274	580	488	1450	30	M 27 x 180	931	12.9	710	262	70,39	647
500	410	2256000	850	246	14	274	600	508	1450	32	M 27 x 180	931	12.9	670	268	90,81	747
530	440	2607000	910	275	14	303	630	538	1450	34	M 27 x 200	931	12.9	630	241	130	939
660	540	4897000	1070	310	15	340	780	670	3300	30	M 36 x 240	931	12.9	530	264	263	1331

Type 52 Shrink Discs matching Stiebel – helical-bevel gears

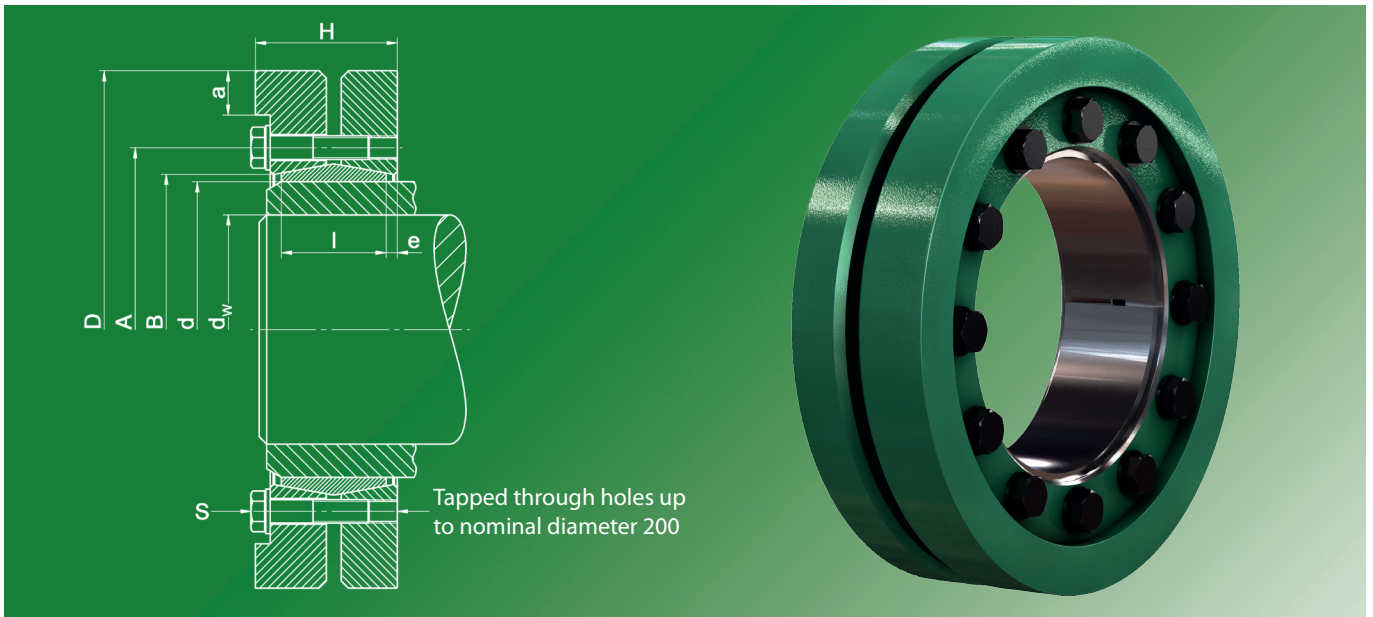

Used symbols

d	[mm]	Nominal diameter of the shrink disc
d_w	[mm]	Shaft diameter
M_{max}	[mm]	Maximal transmittable torque
D	[mm]	Outer diameter
l	[mm]	Length of the inner ring
e	[mm]	Excess length
H	[mm]	Width of the shrink disc
a	[mm]	Width of the protection against contact (guard)
A	[mm]	Pitch circle diameter
B	[mm]	Attachment size
M_A	[Nm]	Tightening torque of the clamping screws
Z		Number of clamping screws
S		Size of the clamping screws
n_{max}	[min ⁻¹]	Permitted rotational frequency
p_N	[N/mm ²]	Moderate pressure to the hub
I	[kgm ²]	Moment of inertia

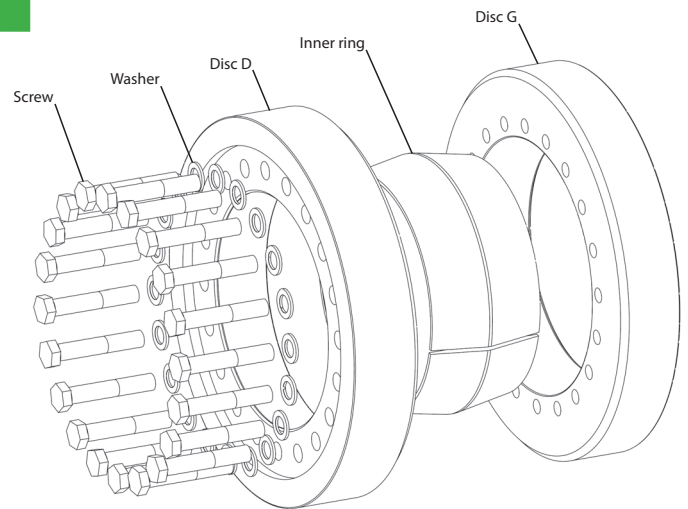

Design of the shrink disc

$d < 120$ - Discs galvanized - without washers

$d \geq 120$ - Discs painted - with washers

Dimensions H & e in unlocked position

min. yield strength $R_{p0.2}$	N/mm ²
Solid shaft	290
Hub	350

Ordering information: TAS Type (e.g.: TAS 5226 ... further sizes on request)

Type 52 Shrink Discs matching Stiebel – helical-bevel gears

Typ	d mm	d _w mm	M _{max} Nm	D mm	l mm	e mm	H mm	a mm	A mm	B mm	M _A Nm	Z Stk	S	DIN	Class	n _{max} min ⁻¹	p _N N/mm ²	I kgm ²	Weight kg
5206	50	40	1200	90	22	2,75	31,5	2	70	53	12	8	M 6 x 25	931	10.9	6300	217	0,0010600	0,8
5208	62	50	2100	110	23	4,25	35,5	3	86	66	12	10	M 6 x 25	931	10.9	5200	210	0,0025909	1,3
5210	75	60	3600	138	25	3,75	38	8	100	79	30	7	M 8 x 30	931	10.9	4100	233	0,0070923	2,3
5212	88	70	6300	155	30	4,5	44,5	9,5	114	94	30	10	M 8 x 35	931	10.9	3600	236	0,0135018	3,4
5214	90	75	7300	155	30	4,5	44,5	9,5	114	94	30	10	M 8 x 35	931	10.9	3600	231	0,0132516	3,3
5216	110	85	10000	185	39	5,5	57	9,5	136	114	59	9	M 10 x 40	931	10.9	3000	208	0,0347437	6,0
5218	138	100	18300	230	46	7,25	68,5	10	175	146	100	10	M 12 x 45	931	10.9	2400	228	0,0989230	11
5220	155	120	30000	265	50	7,25	72,5	19	192	165	100	12	M 12 x 50	931	10.9	2100	224	0,1885000	16
5222	165	120	38700	290	56	7,5	81	20	210	175	250	8	M 16 x 55	931	10.9	1900	258	0,3061438	22
5224	175	135	58400	300	72	8	98	20	220	184	250	10	M 16 x 65	931	10.9	1900	237	0,4221875	28
5226	200	150	95400	350	92	10	122	30	246	204	250	15	M 16 x 80	931	10.9	1600	243	1,0359	51
5228	220	170	149000	370	114	10	144	27,5	270	224	250	20	M 16 x 90	931	10.9	1500	238	1,5287	66

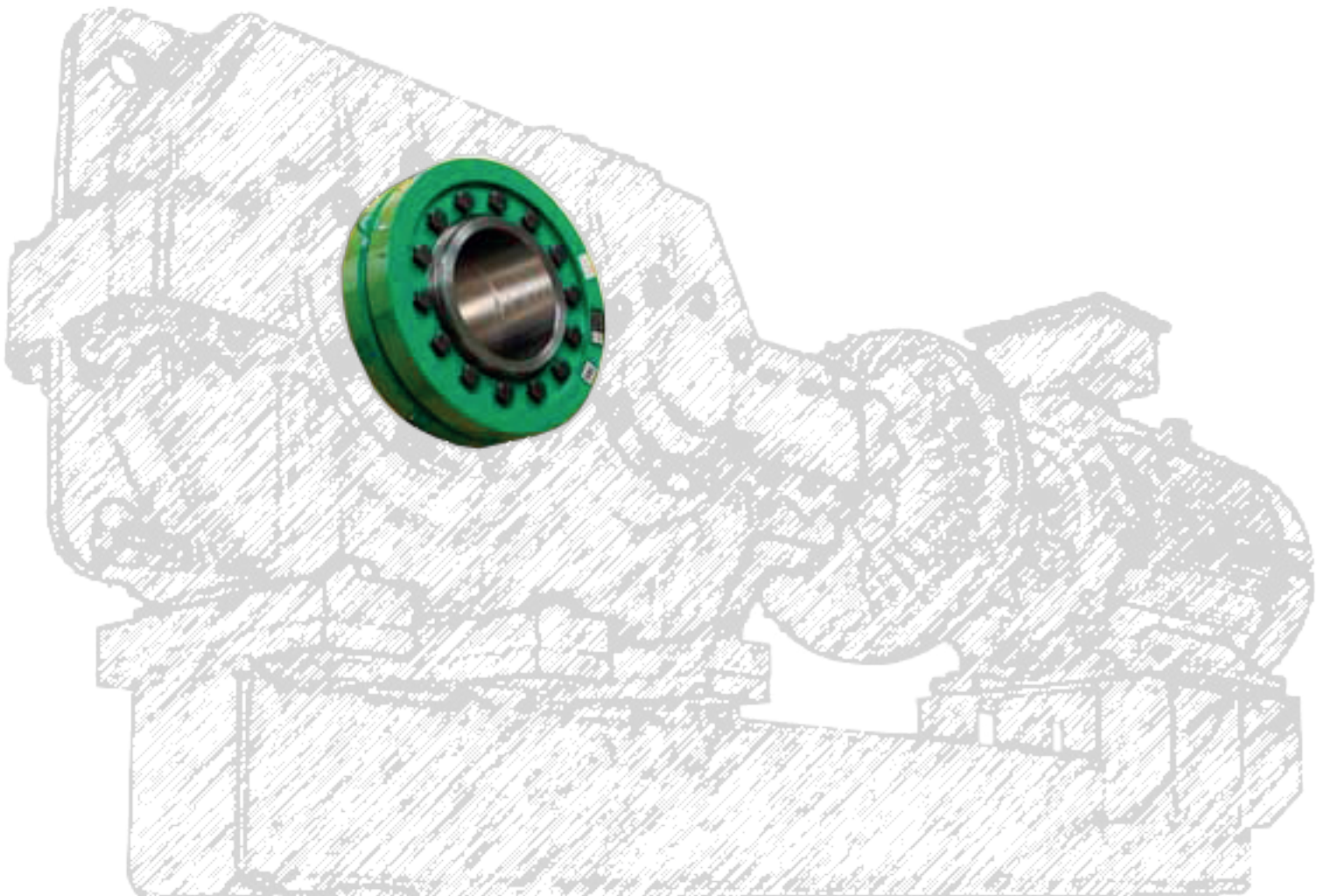

Further products from our company

Clamping devices



TAS 110

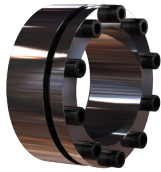

TAS 130

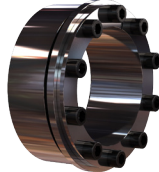

TAS 131



TAS 3003

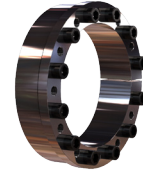

TAS 3006

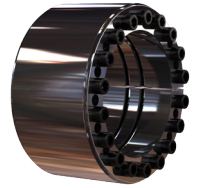

TAS 3012



TAS 3013



TAS 3015



TAS 3015DK



TAS 3020



TAS 4006

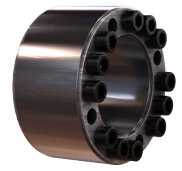

TAS 7014

Shrink discs in two-parts design



TAS 3173

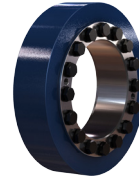

TAS 3171, 3181, 3191, 3193

Shaft couplings

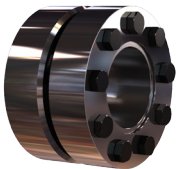

TAS W



TAS WK

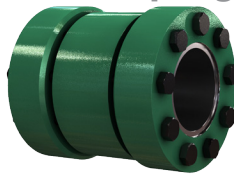

TAS WLA

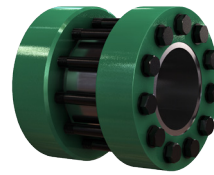

TAS WLB

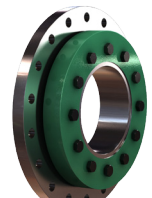

TAS AFS

Flange couplings



TAS FK

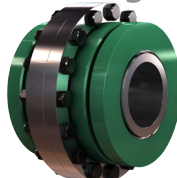

TAS FKB

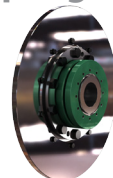

TAS FKBS

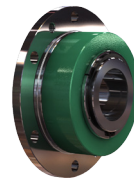

TAS FKH

Hydraulic actuated shrink discs

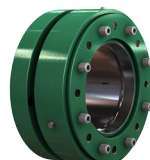
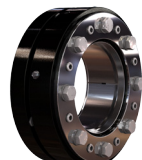

TAS SHS



TAS Schäfer GmbH

Osterfeldstraße 75

58300 Wetter (Ruhr)

Phone: +49 (0) 2335 9781-0

FAX: +49 (0) 2335 72956

E-Mail: info@tas-schaefer.de

Internet: www.tas-schaefer.de