

Motorbases in galvanized steel for motors IEC 56 to 225. Rosta motorbases with automatic pretension for motors IEC 90 to 355.

initial assembly. When installing v-belt for example, no new alignment is needed.

The motorbase is equipped with an adjusting screw which the motor is move with. Motorbase and motor are aligned during

Rails in galvanized steel for motors IEC 56 to 400. Rails can be used to advantage for larger electric motors and heavier

Type TC																				
Item no [Jens S]	Product type	Execution type	Motor size IEC	Power 2-poles kW	Power 4-poles kW	A [mm]	B [mm]	C [mm]	D [mm]	E [mm]	F [mm]	I [mm]	L [mm]	a x b x h [mm]	P [mm]	Ch [mm]	V [mm]	Z [mm]	U [mm]	Weight [kg]
TC80	Slide frame	C	56-80	0,12 to 1,1	0,1 to 0,75	240	154	22	220	85	25	50	16	60 x 110 x 9	113	15	90	25	40	1,5
TC90	Slide frame	C	71-90	0,37 to 2,2	0,25 to 1,5	293	180	25	270	90	45	70	20	45 x 135 x 9	134	16	110	25	40	2,0
TC112	Slide frame	C	80-112	0,75 to 4	0,55 to 4	365	220	30	340	110	43,5	85	23	66,5 x 153,5 x 13	163	17	130	25	50	3,5
TC132	Slide frame	C	90-132	1,5 to 9	1,1 to 7,5	430	250	35	400	134	47,5	100	26	86,5 x 181,5 x 13	185	22	150	25	60	5,8
TC180	Slide frame	C	160-180	15 to 25	11 to 22	532	380	40	500	220	60	125	35	160 x 280 x 15	305	24	260	25	60	12,0
TC225	Slide frame	C	200-225	30 to 45	30 to 45	635	448	50	600	280	55	160	50	225 x 335 x 18	338	27	300	30	70	22,5

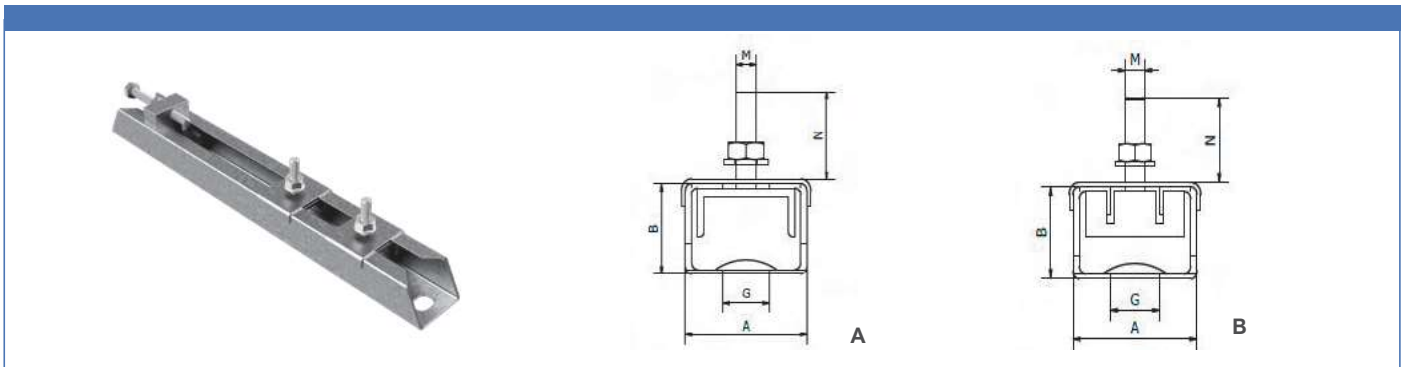

Type TT – Execution A																		
Item no [Jens S]	Product type	Execution type	Motor size IEC	A [mm]	B [mm]	C [mm]	D [mm]	E [mm]	F [mm]	L [mm]	G [mm]	H	M	N [mm]	X max [mm]	Y max [mm]	Weight [kg]	
TT71/6	Slide rails	A	56-71	47	31	312	280	38	13	80	18	M8	M6	25	180	220	2,4	
TT80/8	Slide rails	A	80	47	31	375	343	38	13	80	18	M8	M8	30	240	280	2,7	
TT90/8	Slide rails	A	80-90	59	36	395	355	45	13	100	21	M10	M8	35	245	300	4,3	
TT100/10	Slide rails	A	100	59	36	395	355	45	13	100	21	M10	M10	40	245	300	4,4	
TT112/10	Slide rails	A	100-112	59	36	495	455	45	13	100	21	M10	M10	40	345	400	5,2	

TYPE TT – Execution B																		
Item no [Jens S]	Product type	Execution type	Motor size IEC	A [mm]	B [mm]	C [mm]	D [mm]	E [mm]	F [mm]	L [mm]	G [mm]	H	M	N [mm]	O [mm]	X max [mm]	Y max [mm]	Weight [kg]
TT132/10	Slide rails	B	100-132	65	40	530	480	52	17	120	26	M12	M10	45		360	420	7,8
TT160/12	Slide rails	B	160	65	40	630	580	52	17	120	26	M12	M12	50		460	520	8,8
TT180/12	Slide rails	B	160-180	75	42	700	630	57	17	120	26	M12	M12	50		520	580	12,0
TT225/16	Slide rails	B	200-225	82	50	864	800	68	17	140	27	M16	M16	65	17	670	740	20,4
TT280/20	Slide rails	B	250-280	116	70	1072	1000	90	20	150	27	M18	M20	80	20	870	940	43,0
TT355/24	Slide rails	B	315-355	116	70	1330	1250	90	24	150	27	M18	M24	100	25	1130	1200	52,0
TT400/30	Slide rails	B	400	116	70	1430	1350	90	24	150	30	M18	M30	100	25	1230	1300	58,0