

SIEMENS

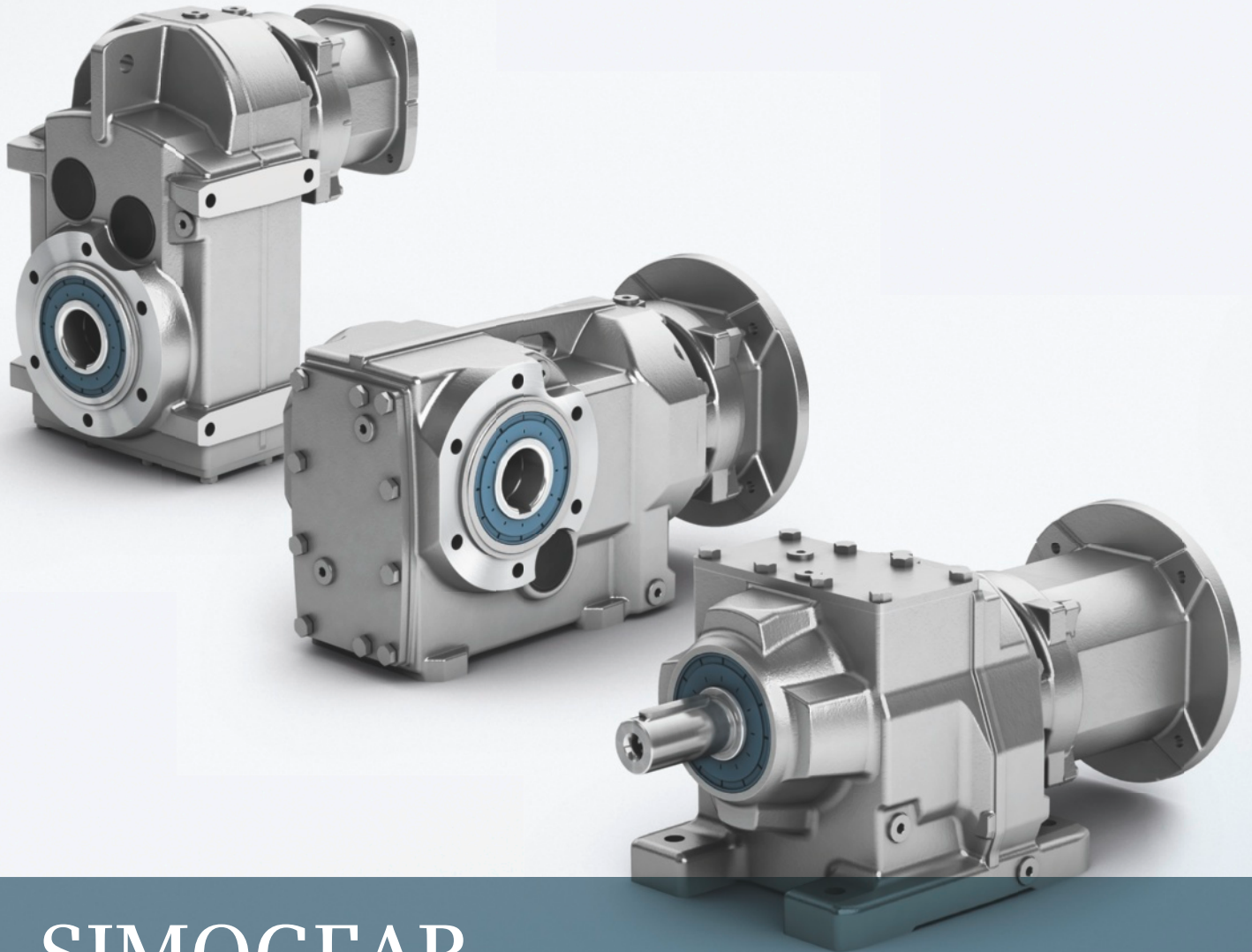

SIMOGEAR

Gearboxes with adapter

Mounting of IEC, NEMA and servo motors



Related catalogs

<p>SIMOGEAR Geared Motors</p> <p>MD 50.1</p> <p>E86060-K5250-A111-A4-7600</p>	
<p>MOTOX Geared Motors</p> <p>D 87.1</p> <p>E86060-K5287-A111-A4-7600</p>	
<p>SIMOTICS Low-Voltage Motors Type series 1LE1, 1MB1 and 1PC1 Frame sizes 71 to 315 Power range 0.18 to 200 kW</p> <p>D 81.1</p> <p>E86060-K5581-A111-A7-7600</p>	
<p>FLENDER Couplings Standard Couplings</p> <p>MD 10.1</p> <p>E86060-K5710-A111-A5-7600</p>	
<p>FLENDER SIG Standard industrial gear units</p> <p>MD 30.1</p> <p>E86060-K5730-A111-A3-7600</p>	
<p>FLENDER SIP Standard Industrial Planetary Gear Units</p> <p>MD 31.1</p> <p>E86060-K5731-A111-A3-7600</p>	
<p>Motion Control Drives SINAMICS Inverters for Single-Axis Drives and SIMOTICS Motors</p> <p>D 31</p> <p>E86060-K5531-A101-A2-7600</p>	

<p>Industrial Communication SIMATIC NET</p> <p>IK PI</p> <p>E86060-K6710-A101-B8-7600</p>	
<p>SIMOTICS NEMA Motors Low Voltage AC Motors Selection and Pricing Guide</p> <p>D 81.2</p> <p>Further details available on the Internet at: www.usa.siemens.com/motors</p>	
<p>SIMOGEAR Konfigurator SIMOGEAR Konfigurator Information/Configuration (CD)</p> <p>SIMOGEAR</p> <p>E86060-D5750-A100-A2-7400</p>	

Additional documentation

You will find all information material, such as brochures, catalogs, manuals and operating instructions for standard drive systems up-to-date on the Internet at the address:

<http://www.siemens.com/gearedmotors>

You can order the listed documentation or download it in common file formats (PDF, ZIP).

SIEMENS

SIMOGEAR Geared motors

Catalog MD 50.11 · 2015

Dear customer,

We are happy to present you with the new Catalog MD 50.11 Edition 2015. This catalog supersedes Catalog MD 50.11 · 2013.



The catalog has been revised and expanded:

- The series of helical, parallel shaft and bevel gearboxes have been expanded with five further sizes with torques up to 19 500 Nm.
- Worm gearboxes of series S with torques of up to 116 Nm have now been added.
- The adapters K2, K3, K4, K5 and K8 for mounting IEC, NEMA and servo motors have been expanded in the power range up to 200 kW.

We hope that you often use our new Catalog MD 50.11 and find it helpful. We will be glad to receive your suggestions and recommendations for improvement under catalogs.industry@siemens.com (please make reference to the catalog name).

As a supplement to this catalog, our SIMOGEAR Configurator electronic catalog helps you when selecting the optimum geared motor. You can call up the 2D and 3D data in all of the usual file formats and directly process it further. Using the integrated ARCHIMEDES engineering tool, you can simply determine the optimum geared motor for frequently occurring applications – such as travel and hoisting drives – in just a few steps.

The SIMOGEAR Configurator software is available as CD-ROM that can be installed on your PC. Please contact your local Siemens office if you would like to obtain this software.

Up-to-date information about SIMOGEAR geared motors is available on the Internet at: www.siemens.com/gearedmotors

You can access our online version of the SIMOGEAR Configurator and online ordering system on the Internet at: www.siemens.com/gearedmotors

With kind regards,

Volker Schacher
Head of Product Management

Siemens AG, Digital Factory, Motion Control, Geared Motors

SIMOGEAR

Gearboxes with adapter

Motion Control

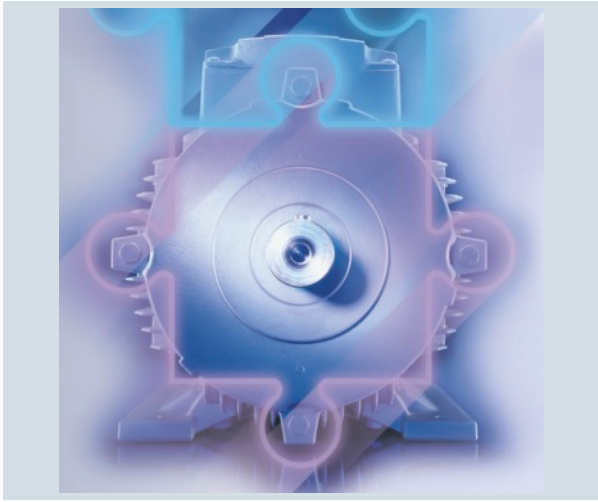

Catalog MD 50.11 · 2015

Supersedes:
Catalog MD 50.11 · 2013

Refer to the Industry Mall for current updates of
this catalog:

www.siemens.com/industrymall

The products contained in this catalog can also be found
in the electronic catalog SIMOGEAR Configurator 2.0.
Article No.:

E86060-D5750-A100-A2-7400 (CD-ROM)

Please contact your local Siemens branch.

© Siemens AG 2015

Introduction	1
Configuring guide	2
Helical gearboxes	3
Parallel shaft gearboxes	4
Bevel gearboxes	5
Helical worm gearboxes	6
Worm gearboxes	7
Adapters	8
Gearbox options	9
Adapter options	10
General options	11
Appendix	12



Printed on paper from
sustainably managed forests and
controlled sources.

www.pefc.org



The products and systems described in
this catalog are manufactured/distributed
under application of a certified quality
management system in accordance with
DIN EN ISO 9001 (Certified Registration
No. DE-409908 QM08). The certificate is
recognized by all IQNet countries.

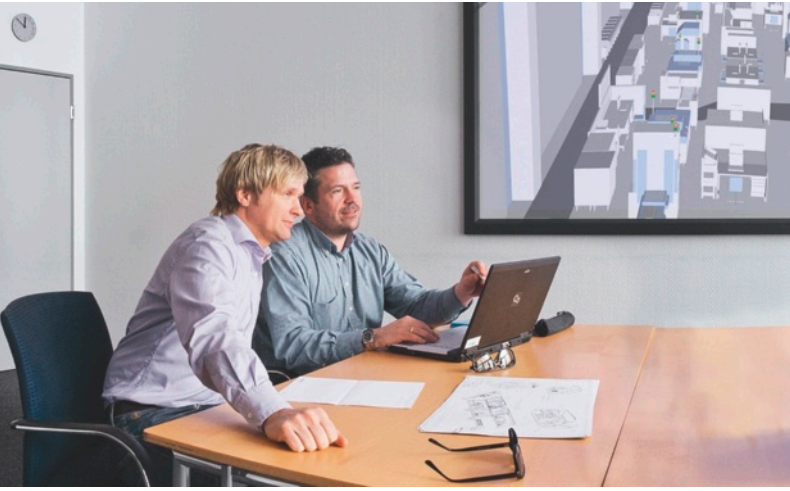



Answers for industry.

Integrated technologies, vertical market expertise and services for greater productivity, energy efficiency, and flexibility.

Siemens is the world's leading supplier of innovative and environmentally friendly products and solutions for industrial companies. End-to-end automation technology and industrial software, solid market expertise, and technology-based services are the levers we use to increase our customers' productivity, efficiency and flexibility.

We consistently rely on integrated technologies and, thanks to our bundled portfolio, we can respond more quickly and flexibly to our customers' wishes. With our globally unmatched range of automation technology, industrial control and drive technology as well as industrial software, we equip companies with exactly what they need over their entire value chain – from product design and development to production, sales and service. Our industrial customers benefit from our comprehensive portfolio, which is tailored to their market and their needs.

Market launch times can be reduced by up to 50% due to the combination of powerful automation technology and industrial software. At the same time, the costs for energy or waste water for a manufacturing company can be reduced significantly. In this way, we increase our customers' competitive strength and make an important contribution to environmental protection with our energy-efficient products and solutions.

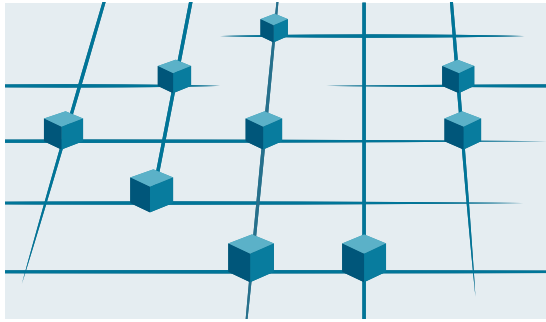

Totally Integrated Automation
Efficient interoperability of all automation components



■ PROFINET
■ Industrial Ethernet
■ PROFIBUS
■ AS-Interface
■ KNX GAMMA instabus

Totally
Integrated
Power

A unique complete approach for all industries

As one of the world's leading automation suppliers, Siemens provides an integrated, comprehensive portfolio for all requirements in process and manufacturing industries. All components are mutually compatible and system-tested. This ensures that they reliably perform their tasks in industrial use and interact efficiently, and that each automation solution can be implemented with little time and effort based on standard products. The integration of many separate individual engineering tasks into a single engineering environment, for example, provides enormous time and cost savings.

With its comprehensive technology and industry-specific expertise, Siemens is continuously driving progress in manufacturing industries – and Totally Integrated Automation plays a key role.

Totally Integrated Automation creates real value added in all automation tasks, especially for:

- **Integrated engineering**
Consistent, comprehensive engineering throughout the entire product development and production process
- **Industrial data management**
Access to all important data occurring in productive operation – along the entire value chain and across all levels
- **Industrial communication**
Integrated communication based on international cross-vendor standards that are mutually compatible
- **Industrial security**
Systematic minimization of the risk of an internal or external attack on plants and networks
- **Safety Integrated**
Reliable protection of personnel, machinery, and the environment thanks to seamless integration of safety technologies into the standard automation

Making things right with Totally Integrated Automation

Totally Integrated Automation, industrial automation from Siemens, stands for the efficient interoperability of all automation components. The open system architecture covers the entire production process and is based on end-to-end shared characteristics: consistent data management, global standards, and uniform hardware and software interfaces.

Totally Integrated Automation lays the foundation for comprehensive optimization of the production process:

- Time and cost savings due to efficient engineering
- Minimized downtime due to integrated diagnostic functions
- Simplified implementation of automation solutions due to global standards
- Better performance due to interoperability of system-tested components

Introduction

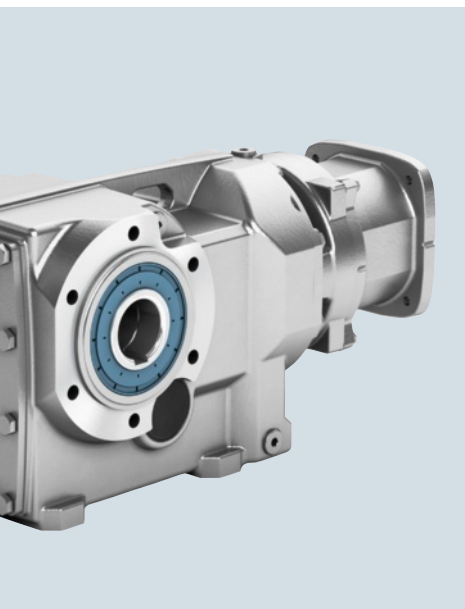

1/2	Orientation
1/2	Overview
1/2	• Gearboxes
1/3	• Torque classes
1/4	• Adapters
1/5	Benefits
1/6	Integration
1/7	Configuration
1/7	• SIMOGEAR Configurator (CD-ROM)
1/8	Guidelines for selection and ordering
	<u>Article No. code</u>
1/8	Overview
1/8	• Ordering data
1/9	• Ordering example
	<u>Type designations</u>
1/10	Overview
	<u>Designs</u>
1/11	Overview
	<u>Notes on selection tables</u>
1/17	Structure of the tables for transmission ratios and torques
1/17	Structure of efficiency tables
	<u>Notes on dimensional drawings</u>
1/18	Overview
1/19	General technical specifications
	<u>Geared motors for use worldwide</u>
1/19	Explosion protection according to ATEX
	<u>Noise</u>
1/19	Geared motor noise
	<u>Direction of rotation</u>
1/20	Overview
1/20	Direction of rotation, input to output

Introduction

Orientation

Overview

Gearboxes

SIMOGEAR gearboxes are available as helical, parallel shaft, bevel, helical worm and worm gearboxes.

State-of-the-art production technology and improved testing methods ensure the highest degree of quality and reliability.

Gearbox type	Gearbox designation	Number of sizes	Maximum output torque	Transmission ratio	Maximum motor power ¹⁾
			T_{2N} Nm	i -	P_1 kW
Helical gearbox					
	Z29 ... Z189 (2-stage)	12	100 ... 19 000	3.4 ... 57	200
	D29 ... D189 (3-stage)	12	100 ... 19 000	36 ... 328	200

Fig. 1/1 Helical gearboxes D/Z

Parallel shaft gearbox					
	FZ29 ... FZ189 (2-stage)	11	150 ... 19 000	4 ... 48	200
	FD29 ... FD189 (3-stage)	11	150 ... 19 000	58 ... 377	200

Fig. 1/2 Parallel shaft gearboxes FD/FZ

Bevel gearboxes					
	B29 ... B49 (2-stage)	3	50 ... 450	3.6 ... 59	9.2

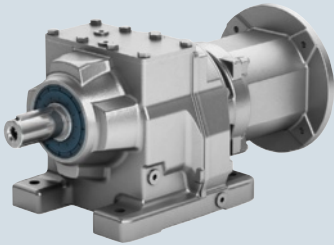
Fig. 1/3 Bevel gearbox B

	K39 ... K189 (3-stage)	10	150 ... 19 500	5.7 ... 237	200

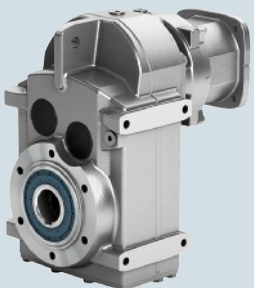
Fig. 1/4 Bevel gearbox K

¹⁾ With 4-pole motor for a 50 Hz line frequency

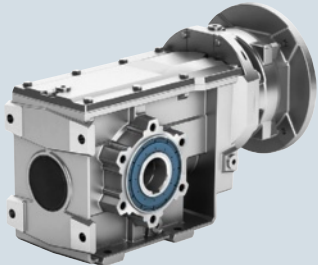
Gearboxes (continued)

Gearbox type	Gearbox designation	Number of sizes	Maximum output torque	Transmission ratio	Maximum motor power ¹⁾
			T_{2N} Nm	i -	P_1 kW
Helical worm gearbox					
	C29 ... C89 (2-stage)	5	61 ... 1 450	6.5 ... 363	7.5

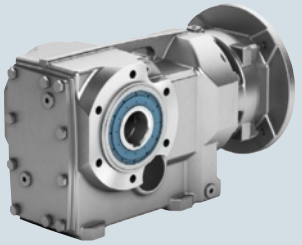
Fig. 1/5 Helical worm gearbox C

Worm gearbox					
	S09 ... S29 (1-stage)	3	33 ... 116	5.0 ... 100	0.75

Fig. 1/6 Worm gearbox S

¹⁾ With 4-pole motor for a 50 Hz line frequency

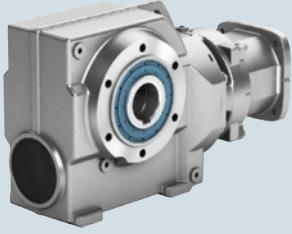
Torque classes

SIMOGEAR gearboxes are classified according to fixed torque steps. Within a torque class, for the various gearbox types, almost the same output torques are achieved.

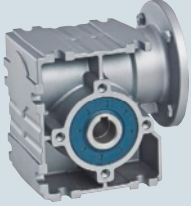
Helical gearboxes Z and D (2-stage and 3-stage)															
Size	-	-	29	39	49	59	69	79	89	109	129	149	169	189	
Maximum output torque	Nm	-	140	200	320	450	600	840	1 680	3 100	5 000	8 000	14 000	19 000	
Parallel shaft gearboxes FZ and FD (2-stage and 3-stage)															
Size	-	-	29	39	-	49	69	79	89	109	129	149	169	189	
Maximum output torque	Nm	-	150	290	-	480	600	1 000	1 850	3 100	4 850	8 000	13 600	19 000	
Bevel gearbox B (2-stage)															
Size	-	-	29	39	-	49	-	-	-	-	-	-	-	-	
Maximum output torque	Nm	-	110	250	-	450	-	-	-	-	-	-	-	-	
Bevel gearbox K (3-stage)															
Size	-	-	-	39	-	49	69	79	89	109	129	149	169	189	
Maximum output torque	Nm	-	-	220	-	420	600	820	1 600	2 900	4 400	8 000	13 000	19 500	
Helical worm gearbox C (2-stage)															
Size	-	-	29	39	-	49	69	-	89	-	-	-	-	-	
Maximum output torque	Nm	-	110	235	-	400	675	-	1 450	-	-	-	-	-	
Worm gearbox S (single-stage)															
Size	-	09	19	29	-	-	-	-	-	-	-	-	-	-	
Maximum output torque	Nm	33	72	116	-	-	-	-	-	-	-	-	-	-	

Introduction

Orientation

Overview

1

Adapters

With directly mounted, highly efficient motors from the LE range, SIMOGEAR offers a broad spectrum of geared motors for the most common drive applications.

Gearboxes of size 29 and larger can be supplied with a variety of mounting adapters which allow the attachment of motors from virtually all Siemens motor ranges in order to meet the requirements of special applications.

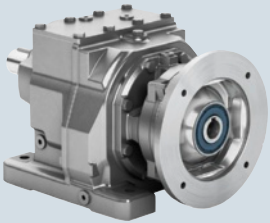
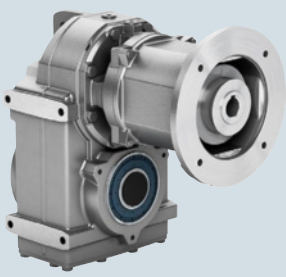
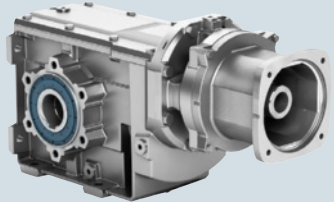
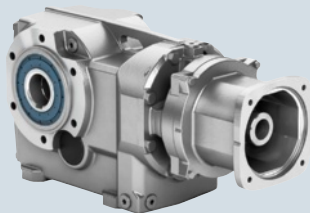
Adapters	Field of application	Options		
		Backstop	Slip clutch with proximity switch	Condensation drain hole
Adapters for mounting an IEC motor				
K4 Short adapter with plug-in connection				
	<ul style="list-style-type: none"> • Universal solution • Short design 			
K2 Coupling adapter with flexible coupling				
	<ul style="list-style-type: none"> • Rugged solution • Harsher environmental conditions • Torsionally flexible cam coupling 	✓	✓	✓
Adapters for mounting a servo motor				
KQ Coupling adapter for mounting a servo motor from the SIMOTICS S-1FK7/-1FT7 ranges				
	<ul style="list-style-type: none"> • Coupling adapter with feather key (KQ) • Coupling adapter without feather key (KQS) • Square shape • Zero-backlash coupling 			
K8 Coupling adapter with flexible coupling for mounting a servo motor from the SIMOTICS M-1PH8 range				
	<ul style="list-style-type: none"> • Square or round shape • Version for motor shafts with feather key • Zero-backlash coupling 			

Adapters (continued)

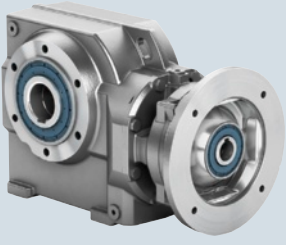
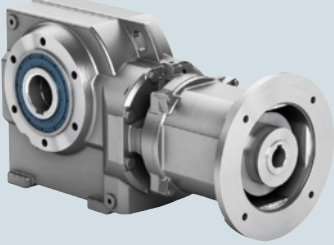
Adapters	Fields of application	Options		
		Backstop	Slip clutch with proximity switch	Condensation drain hole
Adapters for mounting a NEMA motor				
K5 Short adapter with plug-in connection				
	<ul style="list-style-type: none"> • Universal solution • Short design 			
K3 Coupling adapter with flexible coupling				
	<ul style="list-style-type: none"> • Rugged solution • Harsher environmental conditions • Torsionally flexible cam coupling 	✓	✓	✓

Benefits

**High efficiency
for a fast return on investment**

When developing SIMOGEAR gearboxes, significant emphasis was placed on achieving the highest possible energy efficiency.

Using the plug-on pinion principle in the first SIMOGEAR gearbox stage, higher transmission ratios are achieved when compared to gearboxes with slip-on pinion.

This means that frequently instead of 3-stage gearboxes with an efficiency of approx. 94 %, 2-stage helical and parallel shaft gearboxes with a high efficiency of ≥ 96 % can be used.

2-stage SIMOGEAR bevel gearboxes B have a mechanical efficiency of ≥ 96 %. With a range of transmission ratios from $i = 3.5$ to 60, they have been specifically designed to address the requirements in conveyor technology.

**Extremely compact and low weight
for easy handling in the machine or system in the smallest space**

An integrated end shield instead of an adapter plate and end shield reduces the weight and space required in your machine or system.

In addition, interfaces and sealing joints are reduced as a result of the integrated end shield.

With the SIMOGEAR bevel gearboxes, the length was able to be significantly reduced through an optimized bearing design.

SIMOGEAR helical gearboxes D/Z29 to D/Z39 (200 Nm), parallel shaft gearboxes F29 (150 Nm), bevel gearboxes B29 to B49 (450 Nm) and helical worm gearboxes C29 (100 Nm) have an aluminum gearbox housing.

**Harmoniously coordinated modular system
to provide the optimum solution for your particular drive task**

The fine size graduations of SIMOGEAR gearboxes provide you the optimum drive for every application regarding gearbox type, rated output torque and transmission ratio.

When developing SIMOGEAR gearboxes, significant emphasis was placed on achieving well-balanced gearbox properties.

With SIMOGEAR gearboxes you can depend on harmonized and coordinated properties regarding:

- Maximum output torque
- Permissible radial force
- Output shaft diameter
- Bearing service life
- Housing stiffness
- Gearing reliability (fatigue endurable)
- Shaft strength (fatigue endurable)

**Fine ratio stages
to always obtain the output speed required**

With their wide range of transmission ratios, from very low up to very high, SIMOGEAR gearboxes provide the necessary flexibility for your drive application.

As a result of the wide ratio range, 4-pole induction motors can be mainly used – the most cost-effective solution.

Further, the gearboxes are quieter as a result of the lower circumferential velocity of the first gearbox stage.

Introduction

Orientation

1

Benefits (continued)

Intelligent sealing concept for a high degree of maintenance friendliness

An optimally coordinated sealing concept is available for the SIMOGEAR gearbox output shaft to address the various application areas and ambient conditions.

Gearbox size 29 is lubricated for life.

All SIMOGEAR gearboxes with venting have as standard a pressure breather valve.

Modular adapters for connection to many different Siemens motor models

The modular adapters available for SIMOGEAR gearboxes allow the attachment of numerous different motor models from the Siemens motor spectrum.

For example, the following types of motor can be mounted:

- Standard IEC motors
- Synchronous servo motors
- Asynchronous servo motors

Integration

SIMOGEAR geared motors are part of the Siemens Integrated Drive System (IDS).

The Siemens Integrated Drive System (IDS) stands for standardized, tailored and modular components, systems and services. It encompasses the world's most extensive portfolio – from geared motors through motor starters and inverters, identification systems and switchgear up to the automation.

The complete portfolio is exhaustively tested – also in the field – for maximum availability. The components are harmonized and

coordinated with one another with standard interfaces and power bus systems.

Siemens Integrated Drive System (IDS) therefore allows you to reduce your installation and commissioning costs, and at the same time increase flexibility and system availability.

Energy-efficient motors, motor starters, soft-starters and inverters as well as the Power Management system based on SIMATIC PCS 7, SIMATIC WinCC and multi-function measuring devices ensure a high energy saving potential.

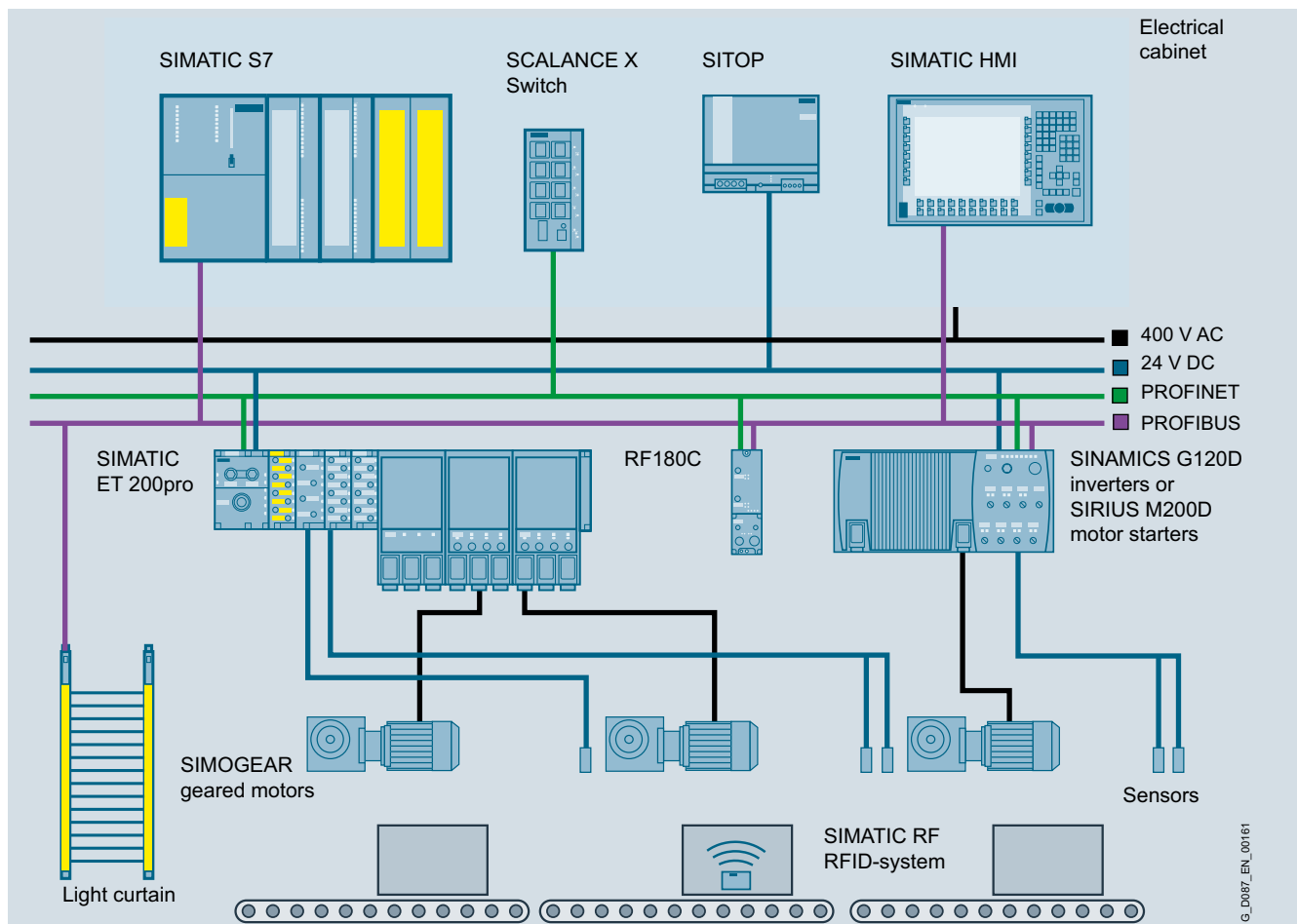

Fig. 1/7 Example of the Siemens Integrated Drive System (IDS) for sophisticated conveyor applications

Configuration

SIMOGEAR Configurator (CD-ROM)

The selection tables list an optimized selection of geared motor combinations regarding size, service factor and number of poles. The SIMOGEAR Configurator contains all of the technically possible combinations and provides you with various wizards to select the optimum drive.

The SIMOGEAR Configurator makes it easy to select the optimum SIMOGEAR geared motor, and in addition to the technical specifications, also supplies the correct article No. and the prices of the geared motors.

Data sheets, circuit diagrams, dimensional drawings to scale and 3D models in the usual formats can be generated for the various products.

Note:

Utilize the new functionality of our SIMOGEAR Configurator electronic catalog.

For the selected mounting position, the 3D dimensional drawings show the exact position of the oil valves.

The ARCHIMEDES engineering tool integrated in the SIMOGEAR Configurator supports you when selecting and dimensioning geared motors for your particular application.

The SIMOGEAR Configurator can be accessed in the Internet at: www.siemens.com/gearedmotors

You can order a version of the SIMOGEAR Configurator that you can install on your PC from your local Siemens office or in the Internet.

Description	Article No.
SIMOGEAR Configurator (CD-ROM)	E86060-D5750-A100-A2-7400
Version 2.0 German/English	

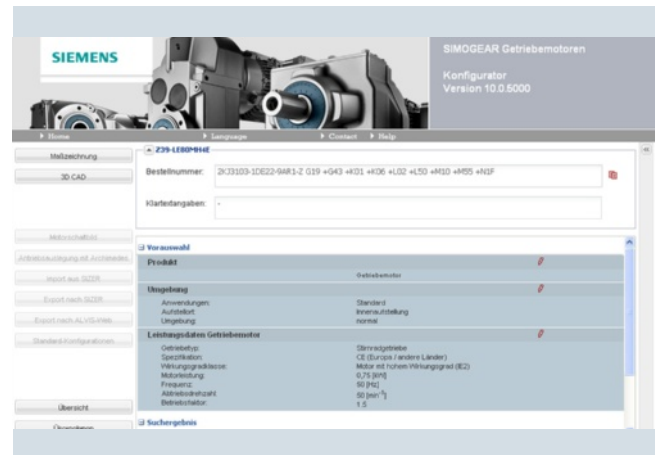

Fig. 1/8 SIMOGEAR Configurator

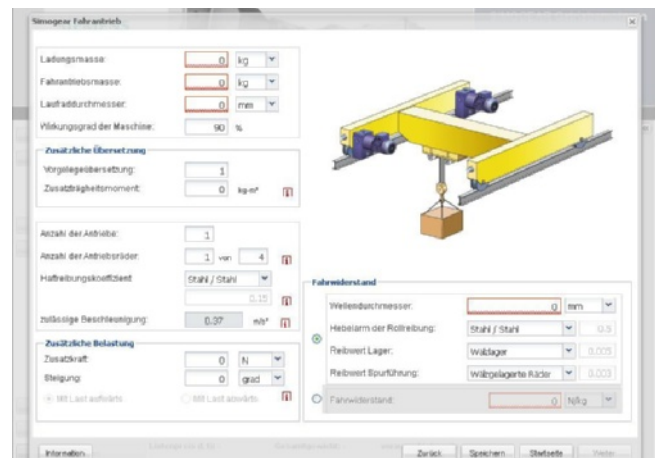

Fig. 1/9 ARCHIMEDES configuration tool

Introduction

Guidelines for selection and ordering

Article No. code

Overview

The article number comprises a combination of digits and letters. To obtain a better overview, the article number is split up into three, hyphenated blocks.

Example:

2KJ3105-1EA04-0AS1+D01

The first block (data positions 1 to 7) designates the gearbox type; the second (data positions 8 to 12) designates the output shaft and the adapter type and size; and additional design characteristics are coded in the third block (data positions 13 to 16).

Structure of the article No.

Position of the article No.	1	2	3	4	5	6	7	-	8	9	10	11	12	-	13	14	15	16	-	Z	
SIMOGEAR geared motors																					
1st to 5th position:	Helical gearbox Z, 2-stage					2	K	J	3	1											
Digit, letter,	Helical gearbox D, 3-stage					2	K	J	3	2											
Letter, digit, digit	Parallel shaft gearbox FZ, 2-stage					2	K	J	3	3											
	Parallel shaft gearbox FD, 3-stage					2	K	J	3	4											
	Bevel gearbox B, 2-stage					2	K	J	3	5											
	Bevel gearbox K, 3-stage					2	K	J	3	5											
	Helical worm gearbox C, 2-stage					2	K	J	3	6											
	Worm gearbox S, single-stage					2	K	J	3	7											
6th to 7th position:	Gearbox size																				
Digit, digit																					
8th position:	Output shaft																				
Digit																					
9th position:	Motor size																				
Letter																					
10th position:	Performance indicator (customs tariff number) for gearbox without motor																			A	
Letter																					
11th position:	Delivery without motor																			0	
Letter																					
12th position:	Short adapter K4 with plug-in connection for mounting an IEC motor																			4	
Digit, digit																					
	Coupling adapter K2 with flexible coupling for mounting an IEC motor																			2	
	Coupling adapter KQ for mounting a servo motor from the SIMOTICS S-1FK7/-1FT7 ranges																			7	
	Coupling adapter K8 for mounting a servo motor from the SIMOTICS M-1PH8 range																			8	
	Short adapter K5 with plug-in connection for mounting a NEMA motor																			5	
	Coupling adapter K3 with flexible coupling for mounting a NEMA motor																			3	
13th position:	Frequency, voltage																			- 0	
Digit																					
14th position:	Foot-mounted design																			A	
Letter	Foot/flange-mounted design																			B	
	Torque arm																				D
	Flange-mounted design																				F
	Housing flange design																				H
15th to 16th position:	Transmission ratio																				
Letter, digit																					
Special designs																					
Coded	Order code required																			- Z	
Non-coded	Plain text required																				

Ordering data

- Complete article No., with a **-Z** suffix, and order code(s) or plain text.
- If a quotation is available, please specify the quotation number in addition to the article No.
- When ordering a complete gearbox as a replacement unit, the serial number of the original gearbox must be specified.

To order the correct adapter design, the input speed of the gearbox and the motor power must be specified with order code Y00 and in plain text (see Table "Additional order codes").

Overview (continued)

Additional order codes

Information	Input speed in continuous operation	Input power Rated motor power
when ordering	rpm	kW
Order code	Y00	Y00
Plain text specification	Y00:*AND@input speed*	Y00:*ANL@input power*
Example of plain text specification	Y00:*AND@1450* (input speed 1 450 rpm)	Y00:*ANL@1.5* (input power 1.5 kW)
Information required	Always	Always

Ordering example

A helical geared motor is required:

- Gearbox type, size Z59
- Adapter type and size K4-90
- Input power 1.5 kW
- Input speed 1500
- Output speed 49, transmission ratio $i = 28.89$
- Solid shaft V35 x 70
- Mounting position M1

This results in the following article No. with order codes

Position of the article No.		1	2	3	4	5	6	7	8	9	10	11	12	13	14	15	16	-	+	Order codes	Plain text specification					
Selection criteria	Requirements																									
Gearbox type, gearbox size	Helical gearbox Z, size 59	2	K	J	3	1	0	5	-	■	.	.	■	■	-	■	■	■	■	-	■	+	.	.	+	.
Output shaft	Solid shaft V35 x 70	2	K	J	3	1	0	5	-	1																
Adapter size	Size 90	2	K	J	3	1	0	5	-	1	E	A														
Gearbox without motor		2	K	J	3	1	0	5	-	1	E	A	0													
Adapter type	K4 for mounting a standard IEC motor	2	K	J	3	1	0	5	-	1	E	A	0	4												
Voltage	Not relevant	2	K	J	3	1	0	5	-	1	E	A	0	4	-	0										
Mounting type	Foot-mounted design	2	K	J	3	1	0	5	-	1	E	A	0	4	-	0	A									
Transmission ratio	$i = 28.89$	2	K	J	3	1	0	5	-	1	E	A	0	4	-	0	A	S	1							
Mounting position	M1	2	K	J	3	1	0	5	-	1	E	A	0	4	-	0	A	S	1	-	Z	+	D01			
Input power, input speed	1.5 kW, 1 500 rpm	2	K	J	3	1	0	5	-	1	E	A	0	4	-	0	A	S	1	-	Z	+	D01	+	Y00	Y00:*ANL@1.5* *AND@1500*

Introduction

Guidelines for selection and ordering

Type designations

Overview

Type designation of the gearbox

Gearbox type	
Helical gearbox	-
Parallel shaft gearbox	F
Bevel gearbox, 2-stage	B
Bevel gearbox, 3-stage	K
Helical worm gearbox 2-stage	C
Worm gearbox, single-stage	S
Stage	
2-stage	Z
3-stage	D
Type	
Shaft	
Solid shaft	-
Hollow shaft	A
Plug-in shaft	E
Mounting	
Foot-mounted design	-
Foot/flange-mounted design	B
Flange-mounted design (A type)	F
Housing flange (C type)	Z
Torque arm	D
Connection	
Feather key / without feather key	-
Shrink disk	S
Splined shaft	T
SIMOLOC assembly system	R
Special features	
Reduced-backlash version	W

Type designation of the adapters

Adapters	
Short adapter with plug-in connection for mounting an IEC motor	K4
Coupling adapter with flexible coupling for mounting an IEC motor	K2
Coupling adapter for mounting a servo motor from the SIMOTICS S-1FK7/-1FT7 ranges	KQ
Coupling adapter for mounting a servo motor from the SIMOTICS M-1PH8 range	K8
Short adapter with plug-in connection for mounting a NEMA motor	K5
Coupling adapter with flexible coupling for mounting a NEMA motor	K3
Special features	
Backstop	X
Variant for coupling adapter KQ	
with feather key	-
without feather key	S

Example:

F	D	F	89	-	K4	X	(132)
↓	↓	↓	↓	↓	↓	↓	↓
(1)	(2)	(3)	(4)	(5)	(6)	(7)	

- (1) Gearbox type
- (2) Stage
- (3) Mounting
- (4) Gearbox size
- (5) Adapter
- (6) Backstop
- (7) Motor size

Overview
Helical gearbox

Fig. 1/10 Modular system, helical gearbox

SIMOGEAR helical gearboxes are available in the following versions for mounting in any position:

- 2 or 3 stages
- Foot-mounted design
- Flange-mounted design
- Design with integrated housing flange
- Combined foot/flange-mounted design
- Solid shaft design with and without feather key

Introduction

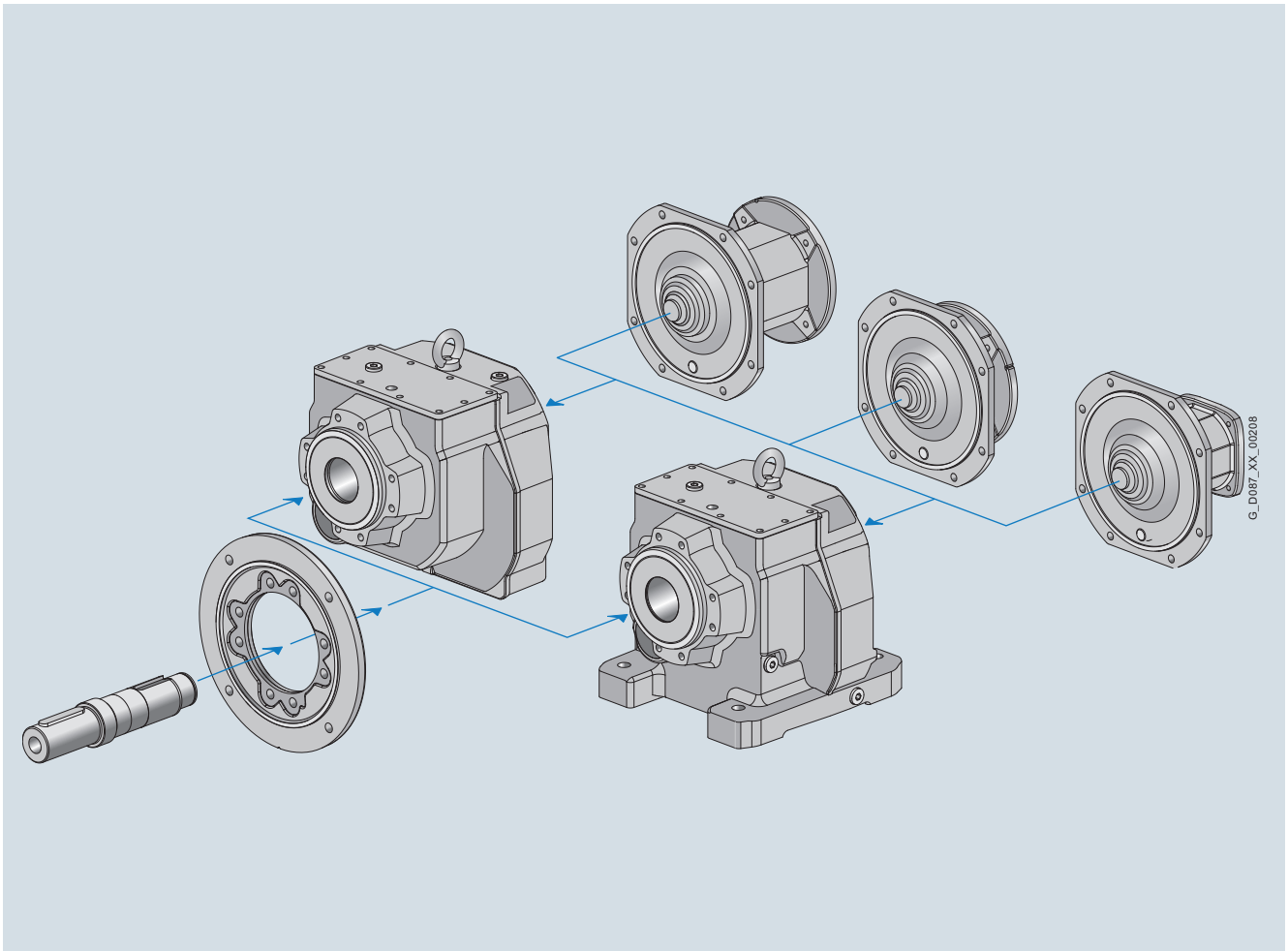
Guidelines for selection and ordering

Designs

Overview (continued)

Parallel shaft gearbox

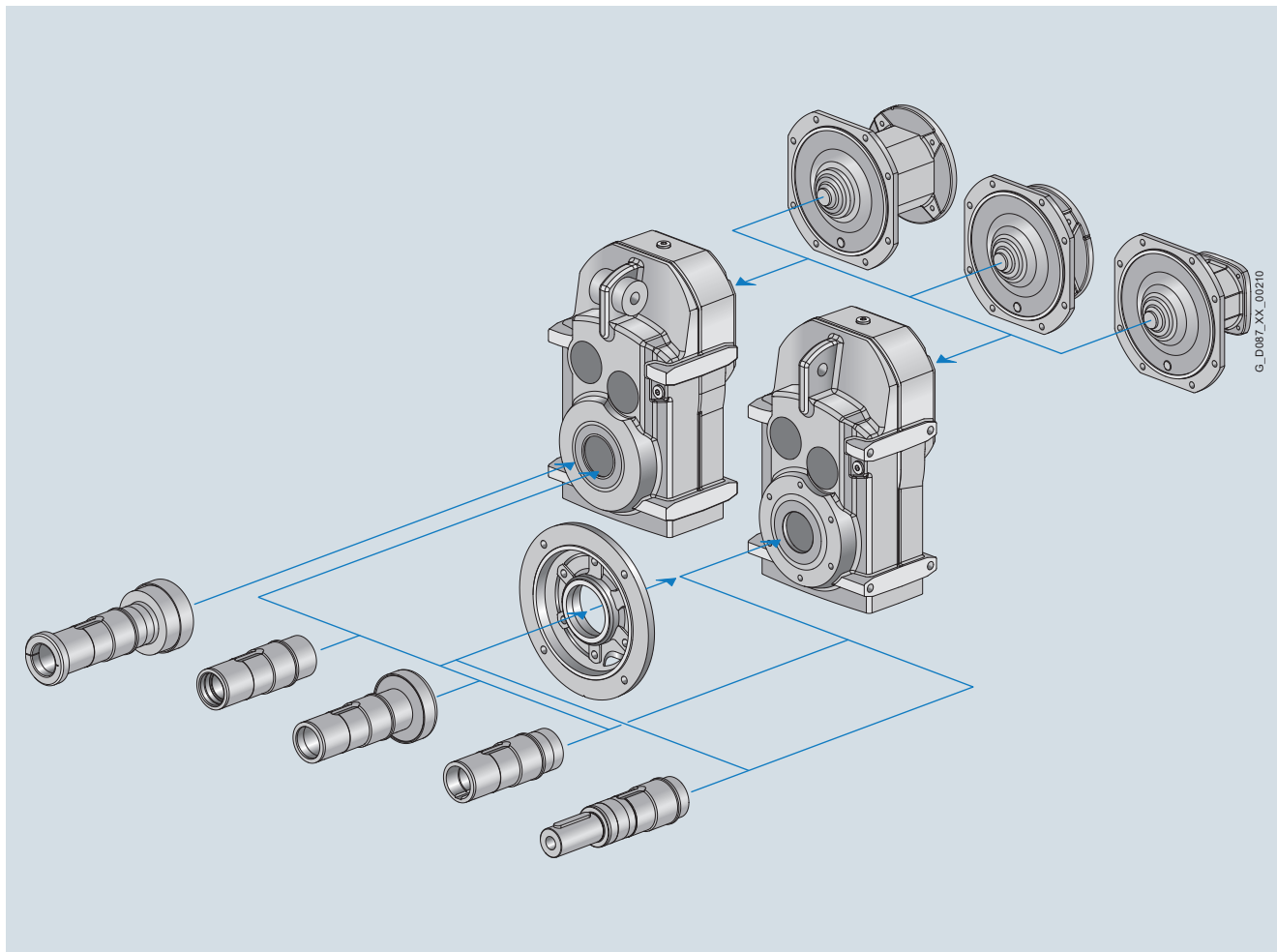

Fig. 1/11 Modular system, parallel shaft gearbox

SIMOGEAR parallel shaft gearboxes are available in the following versions for mounting in any position:

- 2 or 3 stages
- Shaft-mounted design with torque arm
- Flange-mounted design
- Design with integrated housing flange
- Foot-mounted design
- Hollow-shaft design with feather key, splined shaft, shrink disk or SIMOLOC assembly system
- Solid shaft design with and without feather key

Overview (continued)

Bevel gearbox B

Fig. 1/12 Modular system, bevel gearbox B

SIMOGEAR bevel gearboxes B are available in the following versions for mounting in any position:

- 2 stages
- Shaft-mounted design with torque arm
- Flange-mounted design
- Design with integrated housing flange
- Foot-mounted design
- Hollow-shaft design with feather key, splined shaft, shrink disk or SIMOLOC assembly system
- Solid shaft design with feather key (at one end or both ends)

For 2-stage bevel gearboxes B, the torque arm is supplied loose to enable it to be mounted as required on site. The position of the torque arm can be freely selected.

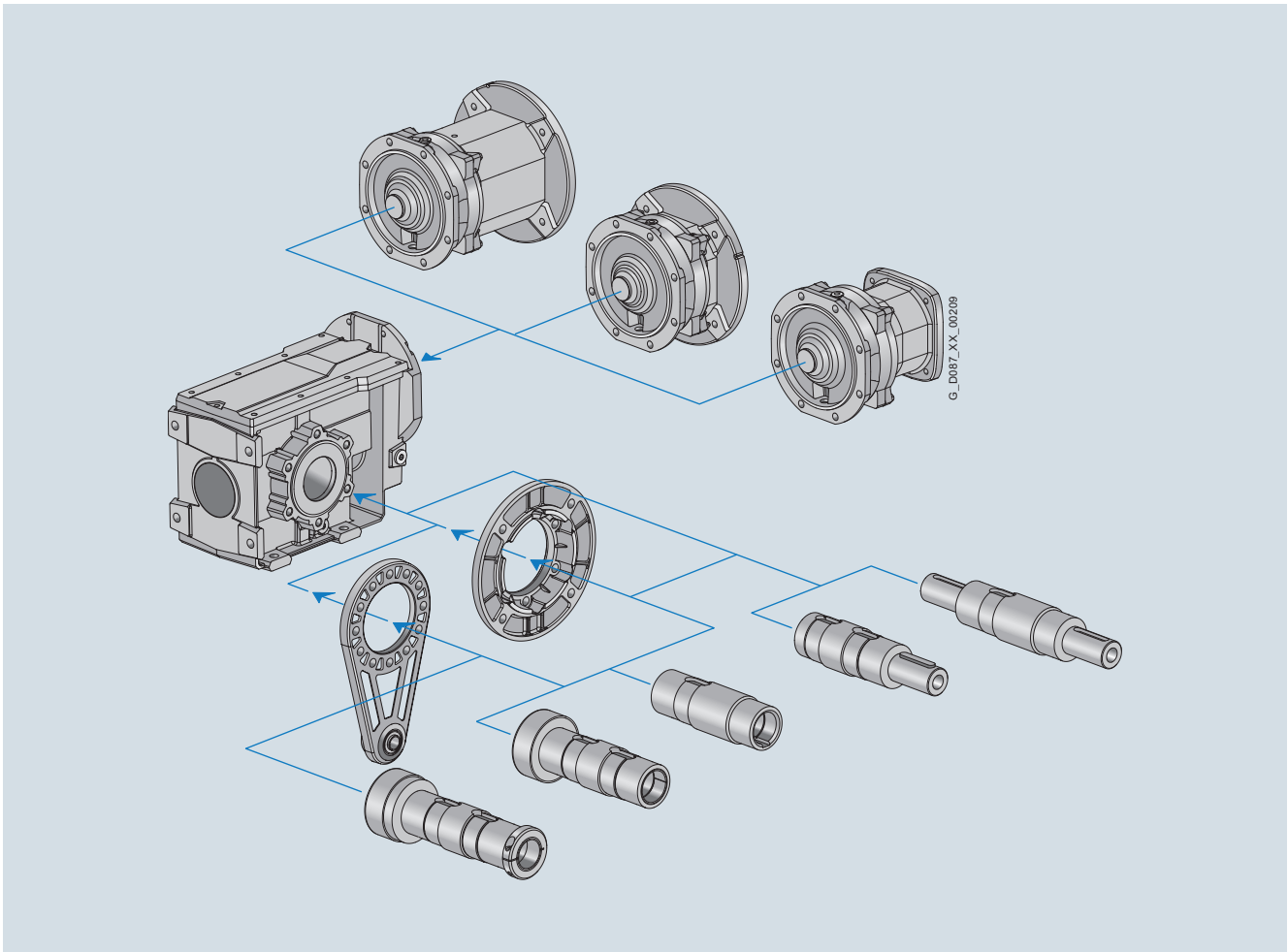
Introduction

Guidelines for selection and ordering

Designs

Overview (continued)

Bevel gearbox K

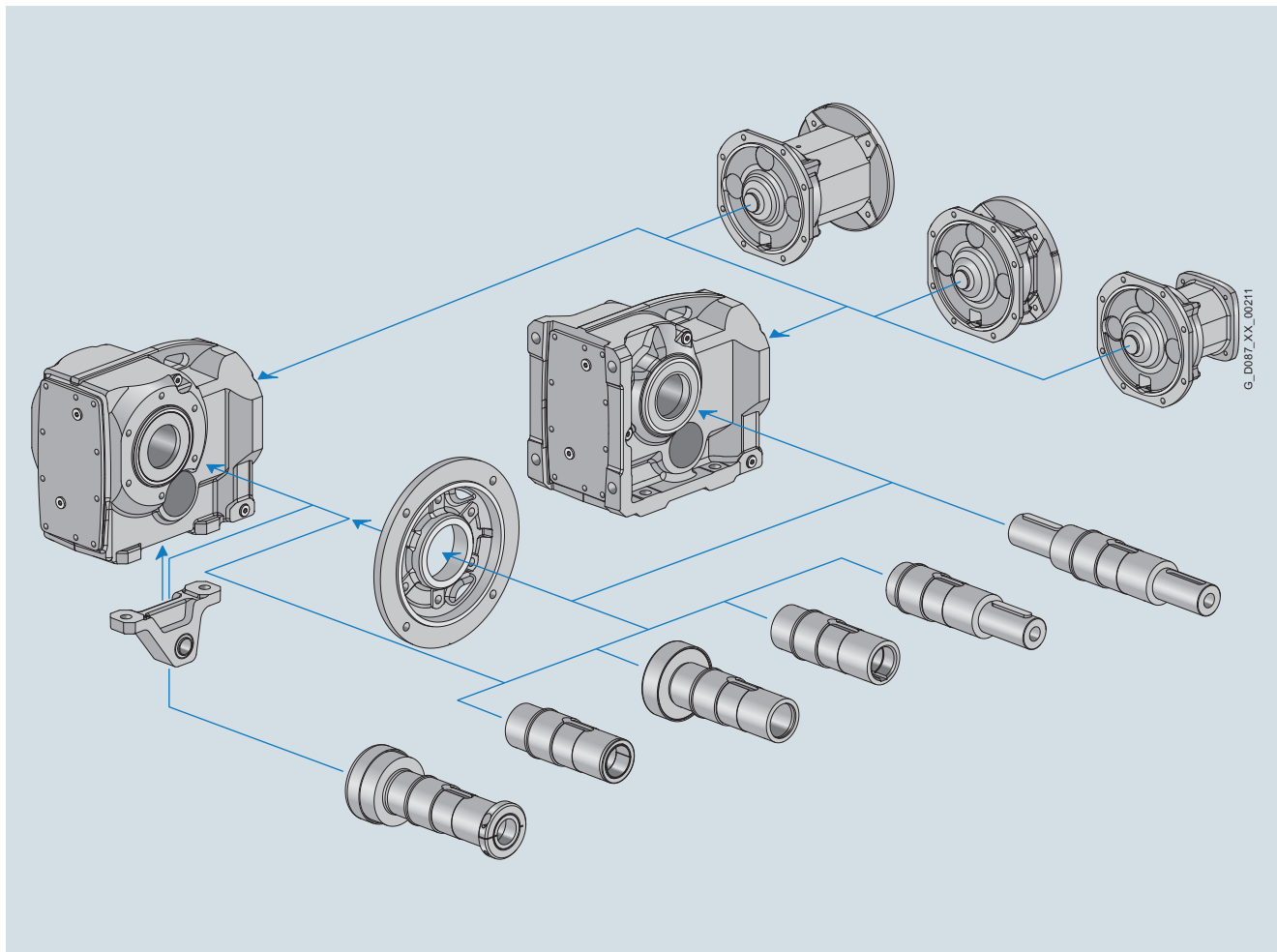

Fig. 1/13 Modular system, bevel gearbox K

SIMOGEAR bevel gearboxes K are available in the following versions for mounting in any position:

- 3 stages
- Shaft-mounted design with torque arm
- Flange-mounted design
- Design with integrated housing flange
- Foot-mounted design
- Hollow-shaft design with feather key, splined shaft, shrink disk or SIMOLOC assembly system
- Solid shaft design with feather key (at one end or both ends)

Overview (continued)**Helical worm gearbox**

Fig. 1/14 Modular system, helical worm gearbox

SIMOGEAR helical worm gearboxes are available in the following versions for mounting in any position:

- 2 stages
- Shaft-mounted design with torque arm
- Flange-mounted design
- Design with integrated housing flange
- Foot-mounted design
- Hollow-shaft design with feather key, shrink disk or SIMOLOK assembly system
- Solid shaft design with feather key (at one end or both ends)

For helical worm gearboxes, the torque arm is supplied loose to enable it to be mounted as required on site. The position of the torque arm can be freely selected.

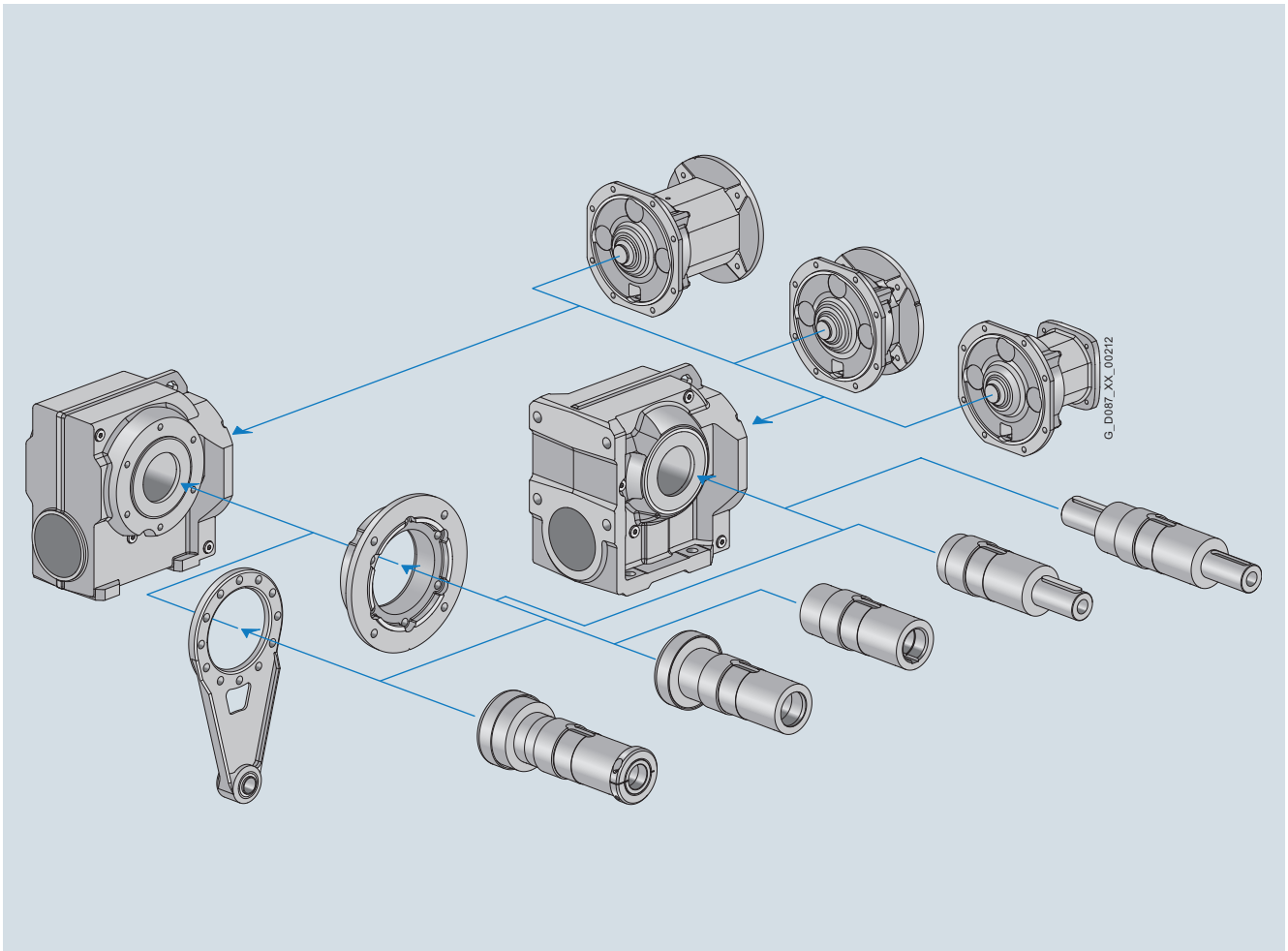
Introduction

Guidelines for selection and ordering

Designs

Overview (continued)

Worm gearbox

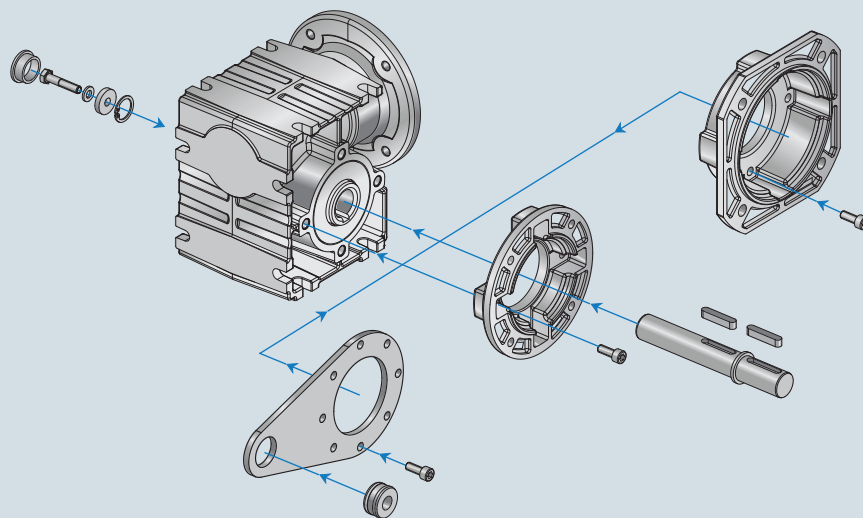

Fig. 1/15 Modular system, worm gearbox

SIMOGEAR worm gearboxes are available in the following versions for mounting in any position:

- 1 stage
- Shaft-mounted design with torque arm
- Flange-mounted design
- Design with integrated housing flange
- Foot-mounted design
- Solid shaft design with feather key (at one end or both ends)
- Hollow-shaft design with feather key or with plug-in shaft

For worm gearboxes, the torque arm is supplied loose to enable it to be mounted as required on site. The position of the torque arm can be freely selected.

Structure of the tables for transmission ratios and torques

In the selection tables for transmission ratios and torques, the gearboxes are sorted according to gearbox type and ratio.

The check marks indicate the permissible combinations of adapters and gearboxes.

Gearbox							Adapter										Article No.					
i	n_2	T_{2N}	F_{R2}	$\phi^{1)}$	J_G	R_{ex}	K4	63	71	80	90	100	112	132	160	180	200	225	250			(Article No. supplement → below)
-	rpm	Nm	N		10^{-4}	-	K2			80	90	100	112	132	160	180	200	225	250	280	315	
							KQ	703	704	706			708	710								
							K8						808	810		813		816		818	822	
							K5	56		140	180		210	250			280	320	360			
							K3	56		140	180		210	250			280	320	360			

D.29																								
217.89	6.7	140	3 710	21	0.02	7626/35	✓	✓																2KJ3202 - A 0 - 0 Q1
↓	↓	↓	↓	↓	↓	↓	↓	↓																↓
(1)	(2)	(3)	(4)	(5)	(6)	(7)	(8)	(9)																(10)

Article No. supplement																				
Shaft design → page 9/39							1 or 9													
Adapter size							K4	B	C	D	E	F	G	H	J					4
							K2			D	E	F	G	H	J				2	
							KQ	A	B	C		D	E						7	
							K8					A	B						8	
							K5	A		B	C		D	E					5	
							K3	A		B	C		D	E					3	
Adapter type																				
Gearbox mounting type → page 9/34							A, B, F or H													

- | | |
|--|---|
| (1) Transmission ratio | (6) Moment of inertia of the gearbox reduced to the input shaft |
| (2) Geared motor output speed at a motor speed of 1 450 rpm | (7) Ratio, number of teeth |
| (3) Maximum gearbox output torque for service factor $f_B = 1$ | (8) Adapter |
| (4) Permissible radial force at the center of shaft extension (l/2) | (9) Possible adapter sizes |
| (5) Torsional backlash in minutes of arc for reduced-backlash version (order code G99)
If torsional backlash is not specified, the option "reduced-backlash version" is not possible with this ratio. | (10) Article No. |

Structure of efficiency tables

Left-hand side

i	$n_{mot} = 700$ rpm				$n_{mot} = 500$ rpm				$n_{mot} = 100$ rpm				Article No.
	n_2	T_{2N}	P_{mot}	η	n_2	T_{2N}	P_{mot}	η	n_2	T_{2N}	P_{mot}	η	
-	rpm	Nm	kW	%	rpm	Nm	kW	%	rpm	Nm	kW	%	

C.29														
265.20	2.6	104	<0.06	57	1.9	103	<0.06	54	0.38	95	<0.06	47		2KJ3601 - A 0 - 0 M2
↓	↓	↓	↓	↓	↓	↓	↓	↓	↓	↓	↓	↓	↓	↓
(1)	(2)	(3)	(4)	(5)	(2)	(3)	(4)	(5)	(2)	(3)	(4)	(5)	(6)	

- | |
|--|
| (1) Transmission ratio |
| (2) Geared motor output speed at motor speed specified at top of table |
| (3) Maximum gearbox output torque for service factor $f_B = 1$ |
| (4) Input power |
| (5) Efficiency |
| (6) Article No. |

Introduction

Guidelines for selection and ordering

Notes on dimensional drawings

Overview

Shaft heights

DIN 747 shaft heights for machines

Shaft height mm	Tolerance mm
≤ 250	-0.5
> 250	-1

Note:

For foot-mounted gearboxes, the mounted motor can extend below the mounting surface of the gearbox.

Shaft extensions

DIN 748-1 cylindrical shaft extensions

Diameter tolerance:

Diameter mm	Tolerance mm
≤ 50	ISO k6
> 50	ISO m6

Centering holes according to DIN 332, form DR:

Diameter mm	Thread size
> 16 ... 21	M6
> 21 ... 24	M8
> 24 ... 30	M10
> 30 ... 38	M12
> 38 ... 50	M16
> 50 ... 85	M20
> 85 ... 130	M24
> 130	M30

Undercut acc. to DIN 509:

Diameter mm	Undercut acc. to DIN 509	Suggested construction, minimum hollow on mating piece
> 16 ... 18	E1.0x0.2	0.9 x 45 °
> 18 ... 50	E1.2x0.2	1.1 x 45 °
> 50 ... 80	E1.6x0.3	1.4 x 45 °
> 80 ... 125	E2.5x0.4	2.2 x 45 °

Hollow shafts

Hollow shaft with parallel key

Diameter tolerance \varnothing : ISO H7 measured using a mandrel gauge

Feather key: acc. to DIN 6885 (high form)

Hollow shafts with shrink disk

Diameter tolerance \varnothing : ISO H7 with mandrel gauge, measured in the area of the shrink disk seat. Hub seat, output side equipped with journal bearing sleeve.

Minimum requirement for the design of the customer shaft:

- Elastic limit $Re \geq 360 \text{ N/mm}^2$
- Module of elasticity, approx. 206 kN/mm^2
- Without tapped hole on the face

Hollow shafts with splines

Splines according to DIN 5480

Hollow shafts for the SIMOLOC assembly system

The diameters of the taper bushing and the bronze bushing are designed to hold a customer shaft with tolerance h11.

Minimum requirement for the design of the customer shaft:

- Bright steel drawn EN10278 (tolerance \varnothing : ISO h11)
- Elastic limit $Re \geq 360 \text{ N/mm}^2$
- Module of elasticity, approx. 206 kN/mm^2
- Straightness less than 0.5 mm/m

Note:

Deviation from the specified straightness will cause radial runout of the customer's shaft. Customer shafts with minor radial runout ensure optimum operating conditions for geared motors. This has a positive impact on the service life of the drive train.

Flange

Centering edge tolerance:

Outer flange diameter mm	Tolerance mm
≤ 230	ISO j6
> 230	ISO h6

Vent valves

The gearboxes are shown in the dimensional drawings with screw plugs.

If venting is required, then depending on the type of construction, an activated vent valve is installed.

The contour dimension can slightly change as a result.

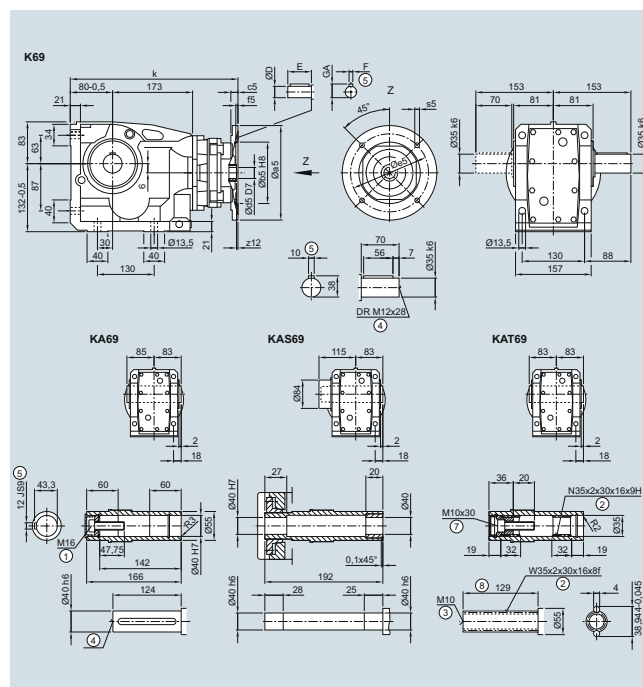

Fig. 1/16 Example, dimensional drawing

Explosion protection according to ATEX

SIMOGEAR gearboxes designed for operation in hazardous environments are available. The explosion-proof versions of the helical, parallel shaft, bevel, helical worm and worm gearboxes comply with Directive 94/9/EC (ATEX) which came into force on January 1, 2003.

The gearboxes are approved for use in zones 1 and 2 (gases) and zones 21 and 22 (dust).

Ex atmosphere/Zone		Category	Frequency	SIMOGEAR gearbox available
G (gas and steam)	D (dust)			
0	20	1	Continuously or long-term	no
1	21	2	Infrequently	yes
2	22	3	Rarely or briefly	yes

Use in explosive atmosphere G (gases) is permissible for temperature classes T1 to T4. With use in explosive atmosphere D (dust), it must be noted that the maximum permissible temperature for the gearbox is 120 °C.

An oil level sensor can be integrated for monitoring in inaccessible areas.

Versions of SIMOGEAR gearboxes

Explosion protection designation	Zone				Order code
	1	2	21	22	
Ex II 2 G/D IIC ck T4/120 °C	✓	✓	✓	✓	K70
Ex II 2 G/D IIB ck T4/120 °C	✓	✓	✓	✓	K80
Ex II 3 G/D IIB ck T4/120 °C			✓	✓	K81
Ex II 3 G/D IIC ck T4/120 °C			✓	✓	K82

Adapter types K2, K3, K4, K5 and KQ are available for mounting Siemens motors on ATEX-compliant gearboxes.

The following ATEX variants of Siemens motors can therefore be selected:

- Flameproof enclosure (Exde)
- Increased Safety (Exe)
- Non-sparking design (ExnA)
- Motors with dust explosion protection

You can select the motors using the DT Configurator:

www.siemens.com/gearedmotors

Noise

Geared motor noise

SIMOGEAR gearboxes have noise levels below the permissible noise levels defined for gearboxes in VDI Guideline 2159 and for motors in IEC 60034-9.

When used in conjunction with the gearboxes, the motor noise values L_{pA} or L_{WA} increase on average by 3 dB (A).

The circumferential velocity of the motor pinion has a significant influence on the additional gearbox noise level. This is the reason that higher speeds or low transmission ratios result in higher noise.

Here, SIMOGEAR gearboxes provide a decisive advantage, as the plug-on pinion of the adapter allows transmission ratios of up to 12 in the input stage.

Code	Description	Unit
L_{pA}	A-weighted measuring-surface sound-pressure level	dB (A)
L_{WA}	Sound power level	dB (A)

Introduction

General technical specifications

Direction of rotation

Overview

Direction of rotation	Clockwise	Counterclockwise
Abbreviation	CW (clockwise)	CCW (counter clockwise)
Description	Clockwise direction of rotation (when viewing the input/output shaft)	Counter clockwise direction of rotation (when viewing the input/output shaft)
Order code	K18	K19

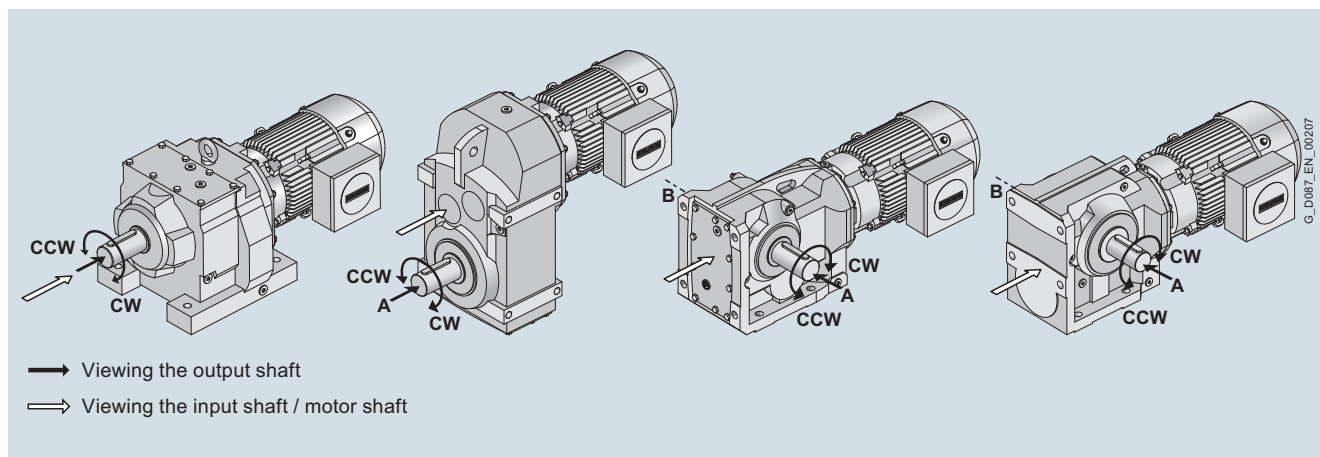

Fig. 1/17 Definition of the direction of rotation

Direction of rotation, input to output

Gearbox type	Size	Gearbox stages	Output side	Direction of rotation	
				Input shaft	Output shaft
Z	19 ... 189	2	-	CW	CW
D	19 ... 189	3	-	CW	CCW
FZ	29 ... 189	2	-	CW	CW
FD	29 ... 189	3	-	CW	CCW
B	19 ... 49	2	A	CW	CW
			B	CW	CCW
K	39 ... 189	3	A	CW	CCW
			B	CW	CCW
C	29 ... 89	2	A	CW	CW
			B	CW	CCW
S	09 ... 29	1	A	CW	CCW
			B	CW	CW

Note:

With bevel gearboxes B and K, helical worm gearboxes C and worm gearboxes S, the direction of rotation must be specified when viewing the A or B side.

Configuring guide

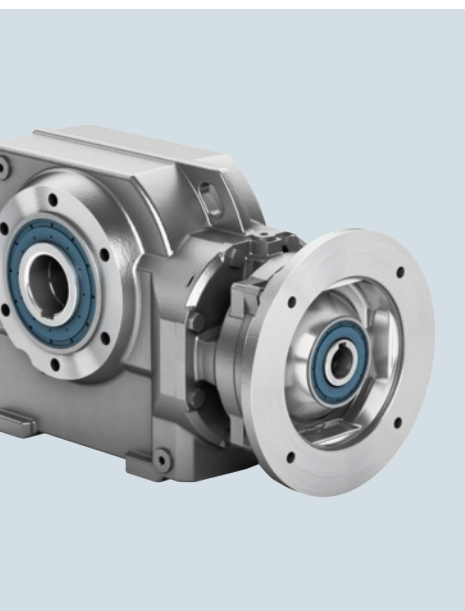

2/2	Determining the drive data
2/2	Configuring sequence
2/3	Checklist
2/4	Configuring a gearbox
2/4	Gearbox efficiency
2/4	<ul style="list-style-type: none"> • Helical, parallel shaft and bevel gearboxes
2/4	<ul style="list-style-type: none"> • Helical worm and worm gearboxes
2/4	<ul style="list-style-type: none"> • Self-locking with worm gearboxes
2/4	<ul style="list-style-type: none"> • Efficiency optimization
2/4	<ul style="list-style-type: none"> • Splashing losses
2/5	Service factor
2/5	<ul style="list-style-type: none"> • Determining the required service factor
2/5	<ul style="list-style-type: none"> • Determining the load classification
2/6	<ul style="list-style-type: none"> • Mass acceleration factor
2/6	<ul style="list-style-type: none"> • Service factors with helical worm gearboxes and worm gearboxes
2/7	Required torque
2/7	Input speed
2/8	Gearbox fastening
2/9	Shaft load and bearing service life
2/9	<ul style="list-style-type: none"> • Available radial force
2/9	<ul style="list-style-type: none"> • Additional factor C for the transmission element type
2/9	<ul style="list-style-type: none"> • Permissible radial force
2/9	<ul style="list-style-type: none"> • Permissible axial force
2/9	<ul style="list-style-type: none"> • Higher permissible radial and axial force
2/9	<ul style="list-style-type: none"> • Definition of the point of application of the radial and axial forces
2/10	<ul style="list-style-type: none"> • Radial force conversion for out of center force application point
2/11	Permissible torque for SIMOLOC assembly system
	Configuring the adapter
2/12	Maximum input speed
2/12	Permissible input torque
2/12	Permissible loading by built-in motor

Configuring guide

Determining the drive data

Configuring sequence

Overview

General configuring notes are provided for the standard versions in this catalog.

SIMOGEAR gearboxes permit individual solutions to be created for a wide range of drive applications. In order to select the correct drive, initially specific data for the application must be known or determined.

For drives operating under special conditions, e.g. frequent reversing, short-time or intermittent duty, abnormal temperatures, reversal braking, extreme cantilever forces at the gearbox output shaft, etc. please contact your Siemens contact person with all of your technical questions.

You will find additional information on our website at

<http://www.siemens.com/gearedmotors>

The flow diagram schematically shows how to select and dimension a geared motor using a traction drive as example. However, the specific requirements and boundary conditions associated with the application in question must always be taken into account.

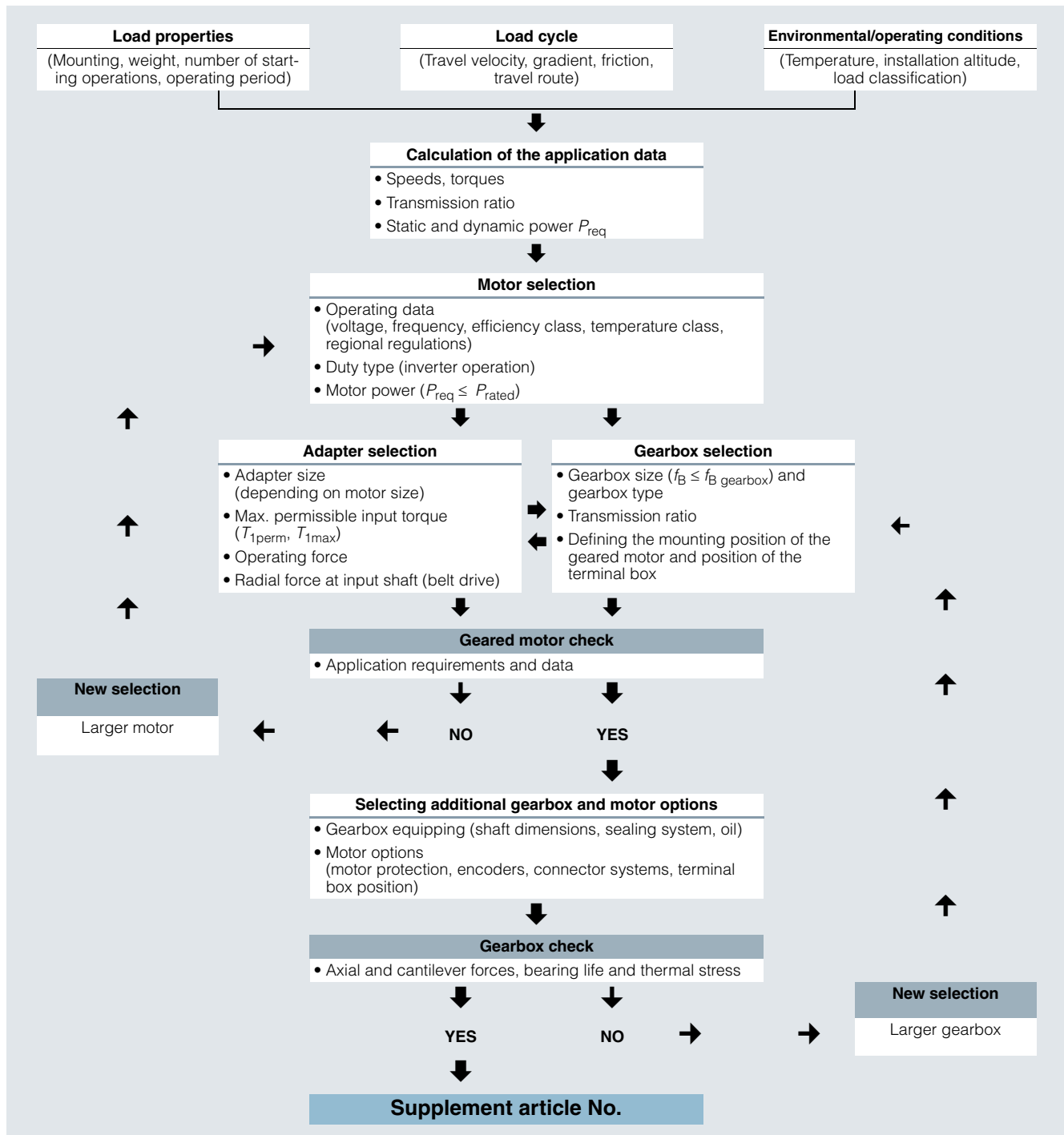

General information		Basic version and load data		
General information	Gearbox type:	<input type="checkbox"/> Helical gearbox <input type="checkbox"/> Parallel shaft gearbox <input type="checkbox"/> Bevel gearbox <input type="checkbox"/> Helical worm gearbox <input type="checkbox"/> Worm gearbox		
	Power rating:	_____	kW	
	Output speed:	_____	rpm	
	Service factor:	_____		
	Starting operations/hour:	_____	s/h	
	Line voltage:	_____	V	
	Line frequency:	<input type="checkbox"/> 50 Hz <input type="checkbox"/> 60 Hz <input type="checkbox"/> For inverter operation <input type="checkbox"/> Maximum frequency	_____	Hz
	Operating period/day:	<input type="checkbox"/> 8 hours <input type="checkbox"/> 16 hours <input type="checkbox"/> 24 hours		
	Environmental conditions			
	Installation altitude:	_____	m	<input type="checkbox"/> Outdoor operation <input type="checkbox"/> Increased environmental stress
Air humidity:	_____	%	<input type="checkbox"/> Normal environmental stress <input type="checkbox"/> Aggressive environmental stress	
Temperature:	_____	from _____ to _____	°C	
Brief description of the system: (e.g. sector, conveyor system, ...)	_____			

Gearbox		Mounting and mounting position	
Gearbox	Mounting position:	<input type="checkbox"/> M1 <input type="checkbox"/> M2 <input type="checkbox"/> M3 <input type="checkbox"/> M4 <input type="checkbox"/> M5 <input type="checkbox"/> M6	
	Mounting type:	<input type="checkbox"/> Foot-mounted design <input type="checkbox"/> Flange-mounted design <input type="checkbox"/> Housing flange design <input type="checkbox"/> Shaft-mounted design	
	Shafts		
	Design:	<input type="checkbox"/> Solid shaft with/without feather key <input type="checkbox"/> Hollow shaft with feather key <input type="checkbox"/> Hollow shaft with shrink disk <input type="checkbox"/> Hollow shaft with splined shaft <input type="checkbox"/> SIMOLOC assembly system	
	Shaft dimensions: (d x l)	_____ x _____	mm
Other options: (e.g. axial/radial force)	_____		

Adapter		Basic version (motor connection)	
Adapter	Adapter type:	<input type="checkbox"/> K4 (IEC) <input type="checkbox"/> K2* (IEC) <input type="checkbox"/> KQ (for 1FK7, 1FT7) <input type="checkbox"/> K8 (for 1PH8) <input type="checkbox"/> K5 (NEMA) <input type="checkbox"/> K3* (NEMA)	* selectable with backstop
	Motor mounting		
	Motor article No.:	_____	
	Other options: (e.g. backstop)	_____	

General options		Surface treatment	
General options	Surface protection:	<input type="checkbox"/> C1 <input type="checkbox"/> C2 <input type="checkbox"/> C3 <input type="checkbox"/> C4 <input type="checkbox"/> C5 <input type="checkbox"/> unpainted <input type="checkbox"/> C3 primed <input type="checkbox"/> C4 primed <input type="checkbox"/> RAL color: _____	
	Other options:		

Configuring guide

Configuring a gearbox

2

Gearbox efficiency

The efficiency of the gearbox is determined in part by the gear teeth, the rolling-contact bearing friction, and the shaft seal friction.

Helical, parallel shaft and bevel gearboxes

SIMOGEAR helical, parallel shaft, and bevel geared motors are extremely efficient. Generally, efficiencies of 96 % (2-stage) and 94 % (3-stage) can be assumed. These gearbox types can be operated with energy-efficient motors to create an excellent solution.

Helical worm and worm gearboxes

The first stage of the helical worm gearbox is designed as a helical stage. With the optimally tuned transmission ratios of the worm stage, the best possible overall efficiency is achieved, which is considerably higher than that of worm gearboxes alone.

SIMOGEAR helical worm gearboxes exhibit efficiency levels of between 65 and 90 %. Precise efficiency data can be found in the tables in chapter "Helical worm gearboxes".

The high degrees of efficiency ensure that the SIMOGEAR helical worm gearboxes are not self-locking.

Running-in period

The tooth flanks on new helical worm and worm gearboxes will not yet be fully smoothed, meaning that the friction angle will be greater and efficiency lower during the running-in period. The higher the transmission ratio, the more pronounced the effect.

The running-in process should take approximately 24 hours of operation at full load. In most cases, the catalog values will then be reached.

Self-locking with worm gearboxes

In respect of restoring torques on worm gearboxes, the efficiency is considerably reduced in comparison to standard efficiency. The restoring efficiency can be calculated as follows: $\eta' = 2 - 1/\eta$. At a standard efficiency of $\eta \leq 0.5$, worm gearboxes are usually self-locking, which is determined by the particular lead angle of the worm gear teeth.

Self-locking only occurs with certain combinations of SIMOGEAR gearboxes and is not always of benefit, as the associated loss of efficiency is then relatively high, which in turn requires increased motor power.

A worm gearbox is "self-locking while stationary" (static self-locking), if it is not possible to start from stationary when the worm wheel is driving.

A worm gearbox is "self-braking while running" (dynamic self-locking), if it is not possible to continue running when the worm wheel is driving while the gearbox is running - that is, if the running gearbox comes to a stop while the worm wheel is driving.

Shocks can neutralize self-locking.

A self-locking gearbox is, therefore, no substitute for a brake or backstop. If you want to use the self-locking braking effect for a technical purpose, please contact us.

Efficiency optimization

As result of the large range of transmission ratios, in many cases, instead of a 3-stage gearbox, a 2-stage SIMOGEAR gearbox can be used.

This means that the efficiency is improved by approximately 2 % when compared to conventional drives.

Further, the efficiency can be improved by optimizing the mounting position and the input speed.

Splashing losses

For certain gearbox types of construction, the first stage can be completely immersed in the gearbox oil. In the case of large gearboxes with a high input speed, particularly with vertical mounting positions, this may lead to increased splashing losses, which cannot be neglected.

If you wish to use gearboxes such as these, then please contact Siemens. If at all possible, you should choose horizontal types of construction in order to keep splashing losses to a minimum.

Service factor

Determining the required service factor

The operating conditions are crucial in determining the service factor and for selecting the geared motor. These are taken into account with service factor f_{Btot} .

In standard operation, i.e. with a uniform load of the driven machine, small masses to be accelerated, and a low number of starting operations, a service factor of $f_{Btot} = 1$ can be selected.

For different operating conditions, the service sector can be taken from the tables.

When the motor power and the gearbox output speed are known, a gearbox type is selected with a service factor that meets the following condition:

$$f_{Btot} = f_{B1} \leq f_B$$

The gearbox size or rated gearbox torque and the resulting service factor are not standardized and depend on the manufacturer.

Determining the load classification

The service factor of the driven machine f_{Btot} is determined from the load classification, number of starting operations, and operating period per day.

The operating conditions can vary greatly. To determine the service factor, empirical values can be derived from the configuration of other similar applications. The driven machines can be assigned to three load groups according to their load classification.

These groups are evaluated according to the mass acceleration factor m_{AF} .

Load groups of driven machines

Load classification	Mass acceleration factor	Driven machine (examples)
I Almost shock-free	≤ 0.3	Electric generators, belt conveyors, apron conveyors, screw conveyors, lightweight elevators, electric hoists, machine tool feed drives, turbo blowers, centrifugal compressors, mixers and agitators when mixing materials with uniform density
II Moderate shock loads	≤ 3	Machine tool main drives, heavy elevators, slewing gear, cranes, shaft ventilators, mixers and agitators when mixing materials with non-uniform densities, reciprocating pumps with multiple cylinders, metering pumps
III Heavy shock loads	≤ 10	Punching presses, shears, rubber kneaders, machinery used in rolling mills and the iron and steel industry, mechanical shovels, large centrifuges, large metering pumps, rotary drilling rigs, briquetting presses, pug mills

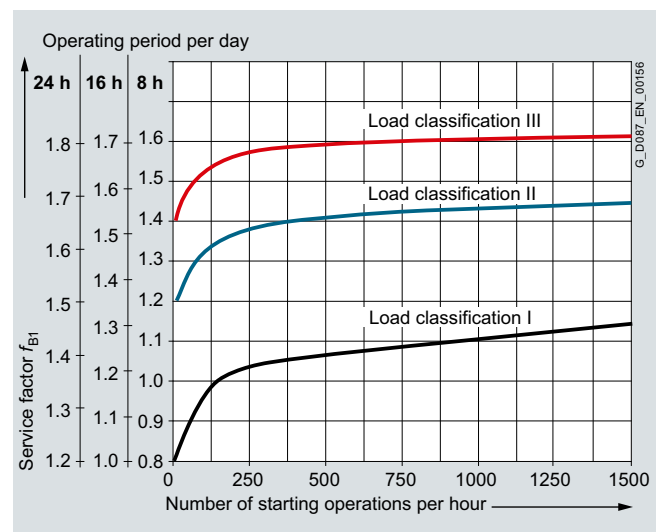

Fig. 2/1 Service factor f_{B1}

Note:

When selecting and dimensioning drives with the following special application conditions, please contact Siemens.

- Frequent reversing
- Short time and intermittent operation
- Abnormal temperatures
- Reversal braking
- Extreme and/or circulating radial forces at the gearbox output shaft
- Fluctuating loads

Configuring guide

Configuring a gearbox

Service factor (continued)

Mass acceleration factor

The mass acceleration factor m_{AF} is calculated as follows:

$$m_{AF} = \frac{J_x}{(J_{mot} + J_B + J_Z)}$$

All external moments of inertia are moments of inertia of the driven machine and the gearbox, which are to be reduced to the motor speed.

The calculation is made using the following formula:

$$J_x = J_2 \cdot \left(\frac{n_2}{n_1}\right)^2 = \frac{J_2}{(i)^2}$$

In most cases the relatively insignificant moment of inertia of the gearbox can be ignored.

The mass acceleration factor m_{AF} is calculated as follows with reference to the gearbox and the adapter:

$$m_{AF} = \frac{J_x + J_G + J_{AD}}{(J_{mot} + J_B + J_Z)}$$

Code	Description	Unit
i	Transmission ratio	-
J_2	Moment of inertia of the load referred to the output speed of the gearbox	kgm ²
J_{AD}	Moment of inertia of the adapter referred to the input speed	kgm ²
J_B	Moment of inertia of the brake	kgm ²
J_G	Moment of inertia of the gearbox referred to the input speed	kgm ²
J_{mot}	Moment of inertia of the motor	kgm ²
J_x	Moment of inertia of the load referred to the input speed	kgm ²
J_Z	Additional moment of inertia of a high inertia fan	kgm ²
m_{AF}	Mass acceleration factor	-
n_1	Input speed of the gearbox	rpm
n_2	Output speed of the gearbox	rpm

Service factors with helical worm gearboxes and worm gearboxes

With helical worm gearboxes and worm gearboxes, two additional service factors are used which take the duty cycle and ambient temperature into account. These additional factors can be determined from the graph opposite. The total service factor is thus calculated as follows:

$$f_{Btot} = f_{B1} \cdot f_{B2} \cdot f_{B3}$$

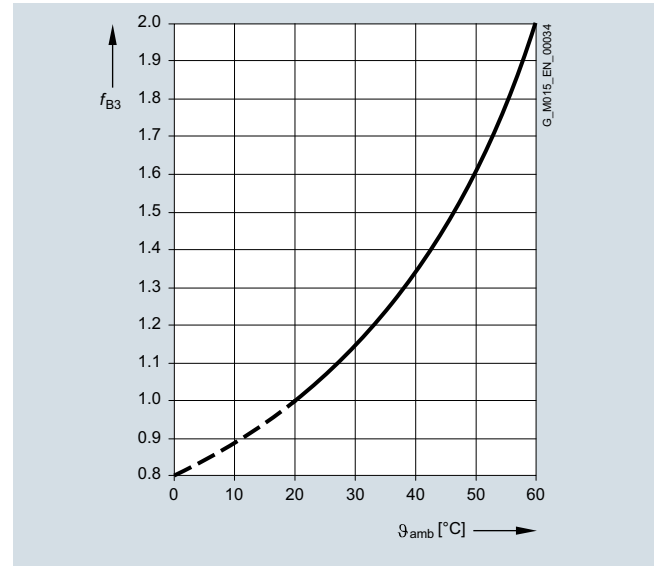

Fig. 2/1 Service factor "ambient temperature"

Example calculation for helical worm gearbox

Mass acceleration factor 2.5 (load classification II), runtime 15 hours per day (read at 16 hours) and 70 starts per hour result in a service factor of $f_{B1} = 1.4$ according to the service factor table.

A load duration of 30 minutes per hour gives a duty cycle (DC) of 50%. Thus, the service factor is $f_{B2} = 0.94$ according to the service factor diagram.

At an ambient temperature of $\vartheta_{amb} = 20^\circ\text{C}$, the service factor diagram gives a service factor of $f_{B3} = 1.0$.

The service factor required is therefore

$$f_{Btot} = 1.4 \cdot 0.94 \cdot 1.0 = 1.32$$

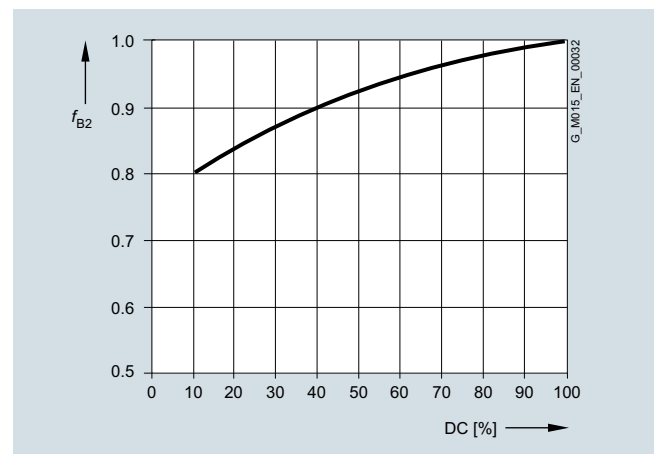

Fig. 2/1 Service factor "short-time duty"

Required torque

Once the load situation (drive data) and the service fact have been clarified, then the required output torque can be determined.

$$T_2 = \frac{P_{\text{mot}} \cdot 9550}{(n_1/i) \cdot \eta} = \frac{P_{\text{mot}} \cdot 9550}{n_2} \cdot \eta$$

Code	Description	Unit
η	Gearbox efficiency	%
i	Transmission ratio	-
n_1	Input speed of the gearbox	rpm
n_2	Output speed of the gearbox	rpm
P_{mot}	Motor power	kW
T_2	Required input torque of the driven machine	Nm

Input speed

For an identical power and output speed, in the selection tables 4-pole geared motors have priority over 6-pole motors.

As a result of the very wide range of transmission ratios of SIMOGEAR gearboxes, it is hardly necessary to use motors with other pole numbers. In addition to the good availability worldwide, 4-pole motors generally offer the optimum solution regarding price, length, noise level and service life.

Further, from the modular system, motors with other pole numbers can be mounted. As a consequence, the following special combinations can be implemented:

- Extremely high output speeds (2-pole motors)
- Extremely low output speeds (8-pole motors)
- Lower noise solutions (6-pole or 8-pole motors)

For inverter operation, the gearboxes are driven at variable speeds.

When configuring the system, we recommend that the maximum input speed in continuous operation is maintained, wherever possible, at 1 500 rpm .

At higher motor speeds above 1 500 rpm you will generally experience higher than average noise levels and a lower than average bearing service life. This depends to a large extent on the transmission ratio and gearbox size in question. Furthermore, higher speeds additionally influence the thermal properties of the gearbox and service intervals.

Configuring guide

Configuring a gearbox

Gearbox fastening

Gearboxes and geared motors are normally secured by bolts of grade 8.8.

When the largest possible motor size is attached to the gearbox and with a higher load classification, elevated levels of vibration and/or smaller service factors, further measures need to be taken for flange-mounted designs of gearboxes and geared motors.

Recommended bolt quality for DZ/ZZ and DF/ZF:

Helical gearboxes DZ/ZZ and DF/ZF with the smallest available output flanges must be bolted to the mounting surface with bolts of grade 10.9 (see table).

Gearbox type	Flange	Strength class of bolt/nut	
DZ/ZZ29	DF/ZF29	A120	10.9 ¹⁾
DZ/ZZ39	DF/ZF39	A120	10.9 ¹⁾
DZ/ZZ49	DF/ZF49	A140	10.9
DZ/ZZ59	DF/ZF59	A160	10.9
DZ/ZZ69	DF/ZF69	A200	10.9
DZ/ZZ79	DF/ZF79	A250	10.9
DZ/ZZ89	DF/ZF89	A300	10.9
DZ/ZZ109	DF/ZF109	A350	10.9
DZ/ZZ129	DF/ZF129	A350	10.9
DZ/ZZ149	DF/ZF149	A450	10.9
DZ/ZZ169	DF/ZF169	A450	10.9
DZ/ZZ189	DF/ZF189	A550	10.9

¹⁾ Use suitable washers underneath the bolt head

Recommended bolt quality for FF/FAF and KF/KAF:

Parallel shaft gearboxes FF/FAF and bevel gearboxes KF/KAF in combination with larger motors must be bolted to the mounting surface with bolts of grade 10.9 (see table).

Gearbox type	Flange	Motor size															
		63	71	80	90	100	112	132	160	180	200	225	250				
FF/FAF39	KF/KAF39	A160	8.8	8.8	8.8	10.9	10.9										
FF/FAF49	KF/KAF49	A200	8.8	8.8	8.8	8.8	10.9	10.9									
FF/FAF69	KF/KAF69	A250	8.8	8.8	8.8	8.8	8.8	8.8	10.9								
FF/FAF79	KF/KAF79	A250	8.8	8.8	8.8	8.8	8.8	8.8	10.9								
FF/FAF89	KF/KAF89	A300		8.8	8.8	8.8	8.8	8.8	10.9	10.9	10.9						
FF/FAF109	KF/KAF109	A350			8.8	8.8	8.8	8.8	8.8	8.8	10.9	10.9					
FF/FAF129	KF/KAF129	A450				8.8	8.8	8.8	8.8	8.8	8.8	8.8	8.8				
FF/FAF149	KF/KAF149	A450					8.8	8.8	8.8	8.8	8.8	8.8	8.8	10.9	10.9	10.9	10.9
FF/FAF169	KF/KAF169	A550						8.8	8.8	8.8	8.8	8.8	10.9	10.9	10.9	10.9	10.9
FF/FAF189	KF/KAF189	A660							8.8	8.8	8.8	8.8	8.8	8.8	8.8	8.8	10.9

We recommend that you consider the following possibilities:

- Selection of a larger output flange
- Use of bolts of grade 10.9
- Use of an anaerobic adhesive to improve the friction lock between the gearbox and the mounting surface

Shaft load and bearing service life

Available radial force

The radial forces either come from the driven machine (mixer, hoisting gear) or they are caused by the transmission elements.

The available radial force F_{Ravail} at the output shaft is obtained as follows:

- The required geared motor output torque T_2
- Average diameter of the mounted transmission element d_0
- Transmission element type, e.g. sprocket wheel

The transmission element type determines the additional factor C (see table).

$$F_{Ravail} = 2000 \cdot \frac{T_2}{d_0} \cdot C$$

Additional factor C for the transmission element type

Transmission element	Explanation	Additional factor C
Gear wheel	> 17 teeth	1.00
	≤ 17 teeth	1.15
Sprocket wheel	≥ 20 teeth	1.00
	14 ... 19 teeth	1.25
	≤ 13 teeth	1.40
Toothed belts	Preloading force	1.50
V-belts	Preloading force	2.00
Flat belts	Preloading force	2.50
Agitator/mixer	Rotating radial force	2.50

Permissible radial force

The permissible radial force F_{R2} is determined by the required bearing service life, among other things. The nominal service life L_{h10} is determined in accordance with ISO 281. Normally, calculating the nominal bearing service life is completely adequate.

The bearing service life can be calculated for special operating conditions and in special cases on request, based on the modified service life L_{na} .

The selection tables specify the permissible radial force F_{R2} for the output shafts of foot-mounted gearboxes with solid shaft. These table values refer to the force application point at the center of the shaft extension and are minimum values, which apply under the most unfavorable conditions (force application angle, mounting position, direction of rotation).

If the values in the table are not sufficient, or if other gearbox designs are being used, please contact Siemens.

Permissible axial force

If no radial force is present, then as permissible axial force F_{ax} (tension or compression), max. 50 % of the permissible radial force can be applied.

Higher permissible radial and axial force

The permissible radial force load can be increased, taking the force application angle α and the direction of rotation into account. Installing reinforced bearings also means that higher loads are permitted on the output shaft.

If higher radial or axial forces or combined loads comprising radial and axial forces occur, then please contact Siemens.

Note:

Bevel gearboxes B and K and helical worm gearboxes C in type of construction M1 with foot mounting on the face side: A maximum of 50 % of the radial force F_{R2} specified in the tables is permissible.

Helical geared motors ZB and DB in foot/flange-mounting designs: When transmitting torque through the flange surface, a maximum of 50 % of the radial force F_{R2} specified in the tables is permissible.

Variables for defining shaft load and bearing service life

Code	Description	Unit
α	Force application angle	°
a	Gearbox constant	kNmm
b, d, l, y, z	Gearbox constants	mm
C	Additional factor to calculate the radial force	-
d_0	Average diameter of the mounted transmission element	mm
F_{ax}	Permissible axial force	N
F_x	Permissible radial force from out of center force application point	N
F_{xperm1}	Permissible radial force, limited by the bearing service life, at a distance of x from the shaft shoulder	N
F_{xperm2}	Permissible radial force, limited by the shaft strength, at a distance of x from the shaft shoulder	N
F_{Ravail}	Available radial force from the mounted transmission element	N
F_{R2}	Permissible radial force at the center of shaft extension (l/2)	N
L_{h10}	Nominal service life	h
L_{na}	Modified service life	h
T_2	Geared motor output torque	Nm
x	Distance from the shaft shoulder up to the point where force is applied	mm

Definition of the point of application of the radial and axial forces

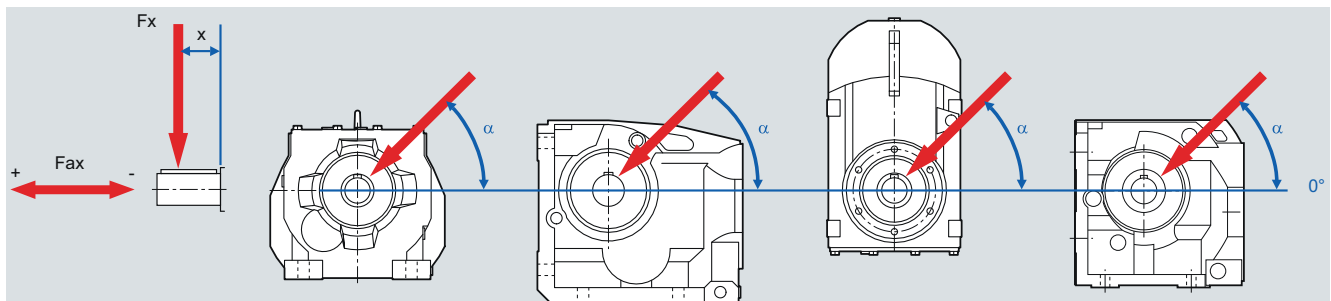

Fig. 2/1 Diagram showing force application point

Configuring guide

Configuring a gearbox

Shaft load and bearing service life (continued)

Radial force – Conversion for out of center force application point

If the force is not applied at the center of the shaft extension, the permissible radial force must be calculated using the following formula:

The lower value of F_{xperm1} (bearing service life) and F_{xperm2} (strength) is the permissible radial force. The calculation is applicable without axial force.

Permissible radial force according to the bearing service life

$$F_{xperm1} = F_{R2} \cdot \frac{y}{(z + x)}$$

Permissible radial force according to the shaft strength

$$F_{xperm2} = \frac{a}{(b + x)}$$

Gearbox constants for calculating the radial force

Gearbox size	Constants					
	y mm	z mm	a kNmm	b mm	d mm	l mm
Helical gearboxes Z and D						
29	104	79	137	12	25	50
39	116	91	109	0	25	50
49	138	108	260	15	30	60
59	143.5	108.5	414	19	35	70
69	169	134	385	0	35	70
79	172.5	132.5	536	0	40	80
89	212.5	162.5	929	0	50	100
109	250	190	1 212	0	60	120
129	297	227	2 051	0	70	140
149	319	234	4 930	0	90	170
169	398	293	7 350	0	110	210
189	469	364	11 235	0	120	210
Parallel shaft gearboxes F						
29	108.5	83.5	159	0	25	50
39	123.5	98.5	146	0	25	50
49	154.5	124.5	239	0	30	60
69	175	140	378	0	35	70
79	191	151	544	0	40	80
89	226	176	884	0	50	100
109	256	196	1 500	0	60	120
129	324	254	2 625	0	70	140
149	385	300	5 525	0	90	170
169	459.5	354.4	7 728	0	110	210
189	538	433	11 655	0	120	210
Bevel gearbox B						
29	117	97	83	0	20	40
39	143.5	113.5	209	0	30	60
49	175	140	392	0	35	70
Bevel gearbox K						
39	123.5	98.5	152	0	25	50
49	154.5	124.5	235	0	30	60
69	175	140	378	0	35	70
79	191	151	556	0	40	80
89	226	176	916	0	50	100
109	256	196	1 470	0	60	120
129	324	254	2 800	0	70	140
149	385	300	5 525	0	90	170
169	459.5	354.5	7 350	0	110	210
189	538	433	10 920	0	120	210

Shaft load and bearing service life (continued)

Gearbox constants for calculating the radial force

Gearbox size	Constants					
	y mm	z mm	a kNm	b mm	d mm	l mm
Helical worm gearbox C						
29	117.5	97.5	84	0	20	40
39	123.5	98.5	157	0	25	50
49	154.5	124.5	236	0	30	60
69	171.5	136.5	410	0	35	70
89	220.0	175.0	736	0	45	90
Worm gearbox S						
09	83.5	63.5	36	0	16	40
19	98.0	78.0	76	0	20	40
29	120.5	100.5	72	0	20	40

Permissible torque for SIMOLOC assembly system

It is important to note that the maximum permissible torque is dependent on the selected machine shaft diameter.

Diameter of customer shaft	Max. possible torque T2					
	Nm					
	29	39	49	69	79	89
Metric shafts						
20	115					
25	150	205				
30		290	375			
35			480	460	840	
40				600	1 000	1 110
50						1 750
Imperial shafts						
0.75"	100					
1"	150	205				
1.1875"		290	375			
1.25"		290	415			
1.375"			480	460	840	
1.4375"			480	500	915	
1.5"				545	1 000	
1.625"				600	1 000	1 180
1.75"						1 375
1.9375"						1 680
2"						1 750

Configuring guide

Configuring the adapter

Maximum input speed

Unless otherwise specified, SIMOGEAR gearboxes can be operated at a motor speed of up to 4 500 rpm for brief periods. Since the speed is rarely constant with high-speed applications, it is necessary to determine a root-mean-square speed as a basis for further calculations.

We recommend that 4-pole motors are mounted in order to achieve optimum gearbox service life. Higher input speeds can have an effect on bearing service life and the thermal properties of the gearbox.

See section "Input speed", page 2/7.

Permissible input torque

The adapters are primarily designed for 4-pole standard three-phase AC motors. Considerably higher torques, which are above the maximum permissible input torque, may occur with special motors.

First of all, the continuous torque of the motor T_{1mot} and the permissible input torque of the adapter T_{1perm} must be checked, along with the maximum torques (starting, breakdown, and braking).

$$T_{1perm} > T_{1mot}$$

Higher input torques are permitted for brief periods provided that they do not exceed 2.5 times the permissible input torque.

The permissible input torques of the adapters can be found in chapter 8 "Adapters".

Variable input torque

Code	Description	Unit
T_{1mot}	Continuous torque of the motor	Nm
T_{1perm}	Permissible input torque of the adapter	Nm

Permissible loading by built-in motor

When a motor is mounted using an adapter, the dimensions of the final unit can be relatively long. In such cases, the maximum permissible operating force F_M must be checked.

The operating force comprises the net weight of the mounted motor plus any acceleration and deceleration forces.

The maximum permissible operating force F_M must not be exceeded!

Variable maximum motor length

Code	Description	Unit
X	Distance from center of gravity	mm
F_M	Maximum permissible operating force from mounted motor	N
F_{Mred}	Reduced maximum permissible operating force from mounted motor	N

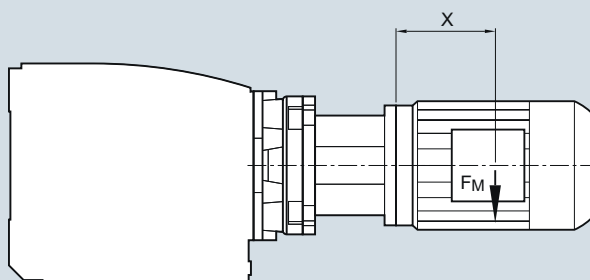

When the distance from the center of gravity is increased, the permissible operating force from the mounted motor F_M must be reduced according to a linear function.

Example:

Distance from center of gravity > X

Motor size = 90

Distance from center of gravity = 150

$$F_{Mred} = F_M \times \frac{115}{150}$$

Maximum permissible operating force from mounted motor

Gearbox type					Adapter size																					
					IEC	63	71	80	90	100	112	132	160	180	200	225	250	280	315							
D./Z.	F.	K.	B.	C.	NEMA	56	56	143	145	182	184	254	256	286	324	364	365									
					X [mm]	80	80	115	115	145	145	190	250	250	300	300	400	400	400	470						
					Maximum permissible operating force from mounted motor F_M																					
29	29		29	29		355	785	655	870	1 200																
39	39	39	39	39; 49		315	315	305	305	480	1 090															
49; 59; 69	49; 69	49; 69; 79	49	69		350	760	705	705	1 490	1 690	1 480														
79	79	89		89			755	1 070	1 160	1 590	2 320	2 570	2 740													
89	89	109						1 050	1 450	2 260	2 540	3 140	2 920	2 920												
109; 129	109; 129	129; 149							1 560	2 240	2 530	3 850	5 230	4 500	3 720	6 380										
149	149	169								2 210	2 490	4 480	5 230	4 500	3 720	7 100	6 880									
169; 189	169; 189	189									2 450	4 420	5 230	4 500	3 720	7 100	6 880	11 200	16 500							

Helical gearboxes

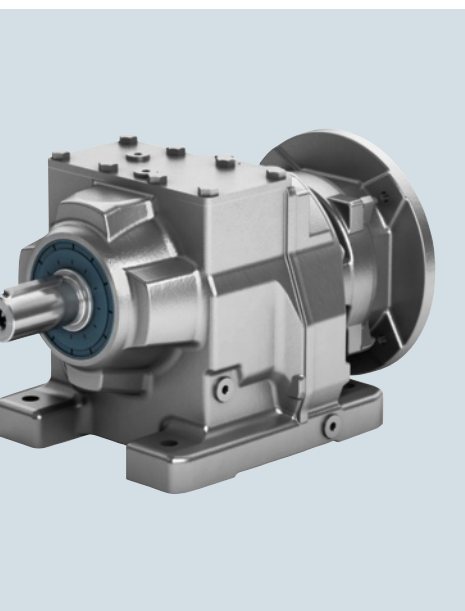

3/2	Orientation	3/68	Dimensions (continued)
3/3	Transmission ratios and torques		<u>Helical gearbox with adapter KQ</u>
3/3	Selection and ordering data	3/68	D/Z29
3/27	Dimensions	3/69	DB/ZB29
3/27	Dimensional drawing overview	3/70	DF/ZF29
	<u>Helical gearbox with adapter K4</u>	3/71	DZ/ZZ29
3/30	D/Z29	3/72	D/Z39
3/31	DB/ZB29	3/73	DB/ZB39
3/32	DF/ZF29	3/74	DF/ZF39
3/33	DZ/ZZ29	3/75	DZ/ZZ39
3/34	D/Z39	3/76	D/Z49 and DB/ZB49
3/35	DB/ZB39	3/77	DF/ZF49
3/36	DF/ZF39	3/78	DZ/ZZ49
3/37	DZ/ZZ39	3/79	D/Z59 and DB/ZB59
3/38	D/Z49 and DB/ZB49	3/80	DF/ZF59
3/39	DF/ZF49	3/81	DZ/ZZ59
3/40	DZ/ZZ49	3/82	D/Z69 and DB/ZB69
3/41	D/Z59 and DB/ZB59	3/83	DF/ZF69
3/42	DF/ZF59	3/84	DZ/ZZ69
3/43	DZ/ZZ59	3/85	D/Z79 and DB/ZB79
3/44	D/Z69 and DB/ZB69	3/86	DF/ZF79
3/45	DF/ZF69	3/87	DZ/ZZ79
3/46	DZ/ZZ69	3/88	D/Z89 and DB/ZB89
3/47	D/Z79 and DB/ZB79	3/89	DF/ZF89
3/48	DF/ZF79	3/90	DZ/ZZ89
3/49	DZ/ZZ79	3/91	D/Z109
3/50	D/Z89 and DB/ZB89	3/92	DF/ZF109
3/51	DF/ZF89	3/93	DZ/ZZ109
3/52	DZ/ZZ89	3/94	D/Z129
3/53	D/Z109	3/95	DF/ZF129
3/54	DF/ZF109	3/96	DZ/ZZ129
3/55	DZ/ZZ109	3/97	D/Z149
3/56	D/Z129	3/98	DF/ZF149
3/57	DF/ZF129	3/99	D/Z169
3/58	DZ/ZZ129	3/100	DF/ZF169
3/59	D/Z149	3/101	D/Z189
3/60	DF/ZF149	3/102	DF/ZF189
3/61	D/Z169		<u>Helical gearbox with adapter KQS</u>
3/62	DF/ZF169	3/103	D./Z.29 to D./Z.189
3/63	D/Z189		<u>Helical gearbox with adapter K8</u>
3/64	DF/ZF189	3/105	D./Z.49 to D./Z.189
	<u>Helical gearbox with adapter K2</u>		<u>Helical gearbox with adapter K5</u>
3/65	D./Z.29 to D./Z.189	3/107	D./Z.29 to D./Z.189
			<u>Helical gearbox with adapter K3</u>
		3/109	D./Z.29 to D./Z.189

SIMOGEAR Gearboxes

Helical gearboxes

Orientation

SIMOGEAR helical gearboxes Z and D

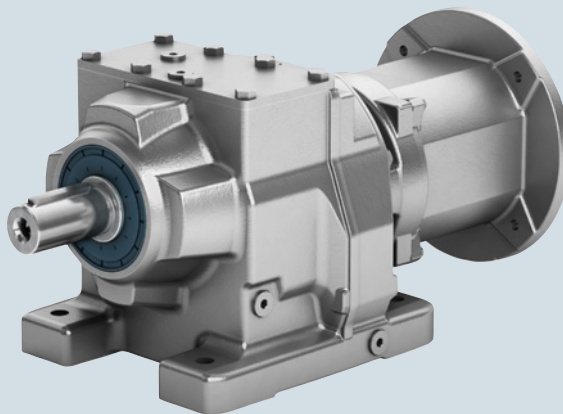

Fig. 3/1 Helical gearboxes Z and D

Gearbox designation	Number of sizes	Maximum output torque	Transmission ratio	Maximum motor power
		T_{2N} Nm	i -	P_1 kW
Z29 ... Z189 (2-stage)	12	100 ... 19 000	3.4 ... 57	55
D29 ... D189 (3-stage)	12	100 ... 19 000	36 ... 328	55

SIMOGEAR helical gearboxes are available in the following versions for mounting in any position:

- 2 or 3 stages
- Foot-mounted design
- Flange-mounted design
- Design with integrated housing flange
- Combined foot/flange-mounted design

Selection and ordering data

Gearbox							Adapter												Article No.						
i	n_2	T_{2N}	F_{R2}	ϕ ¹⁾	J_G	R_{ex}	K4	63	71	80	90	100	112	132	160	180	200	225	250			(Article No. supplement → below)			
-	rpm	Nm	N		10^{-4}	-	K2			80	90	100	112	132	160	180	200	225	250	280	315				
							KQ		703	704	706		708	710											
							K8						808	810		813		816		818	822				
							K5	56		140	180		210	250			280	320	360						
							K3	56		140	180		210	250			280	320	360						
D.29																									
217.89	6.7	140	3 710	21	0.02	7626/35	✓	✓															2KJ3202 - ■ ■ A 0 ■ - 0 ■ Q1		
192.93	7.5	140	3 710	21	0.03	67527/350	✓	✓																2KJ3202 - ■ ■ A 0 ■ - 0 ■ P1	
167.63	8.7	140	3 710	21	0.04	58671/350	✓	✓																	2KJ3202 - ■ ■ A 0 ■ - 0 ■ N1
152.39	9.5	140	3 710	21	0.05	58671/385	✓	✓	✓	✓															2KJ3202 - ■ ■ A 0 ■ - 0 ■ M1
129.68	11	140	3 710	21	0.06	45387/350	✓	✓	✓	✓															2KJ3202 - ■ ■ A 0 ■ - 0 ■ L1
117.89	12	140	3 710	21	0.08	45387/385	✓	✓	✓	✓															2KJ3202 - ■ ■ A 0 ■ - 0 ■ K1
102.79	14	140	3 710	21	0.09	14391/140	✓	✓	✓	✓	✓														2KJ3202 - ■ ■ A 0 ■ - 0 ■ J1
92.01	16	140	3 710	21	0.12	35424/385	✓	✓	✓	✓	✓														2KJ3202 - ■ ■ A 0 ■ - 0 ■ H1
81.71	18	140	3 710	21	0.14	11439/140	✓	✓	✓	✓	✓														2KJ3202 - ■ ■ A 0 ■ - 0 ■ G1
75.42	19	140	3 710	21	0.17	34317/455	✓	✓	✓	✓	✓														2KJ3202 - ■ ■ A 0 ■ - 0 ■ F1
65.52	22	140	3 710	21	0.19	32103/490	✓	✓	✓	✓	✓														2KJ3202 - ■ ■ A 0 ■ - 0 ■ E1
56.93	25	140	3 710	21	0.19	9963/175	✓	✓	✓	✓	✓														2KJ3202 - ■ ■ A 0 ■ - 0 ■ D1
51.40	28	140	3 710	21	0.25	14391/280	✓	✓	✓	✓	✓														2KJ3202 - ■ ■ A 0 ■ - 0 ■ C1
48.37	30	140	3 710	21	0.29	28782/595	✓	✓	✓	✓	✓														2KJ3202 - ■ ■ A 0 ■ - 0 ■ B1
42.17	34	140	3 710	21	0.33	1476/35	✓	✓	✓	✓	✓														2KJ3202 - ■ ■ A 0 ■ - 0 ■ A1

1) Only in conjunction with reduced-backlash version

Article No. supplement

Shaft design	→ Page 9/39	1 or 9																							
Adapter size		K4	B	C	D	E	F	G	H	J	K	L	M	N											4
		K2			D	E	F	G	H	J	K	L	M	N	P	Q									2
		KQ	A	B	C		D	E																	7
		K8					A	B		C		D		E	F										8
		K5	A		B	C		D	E		F	G	H												5
		K3	A		B	C		D	E		F	G	H												3
Adapter type																									
Gearbox mounting type	→ Page 9/34		A, B, F or H																						

SIMOGEAR Gearboxes

Helical gearboxes

Transmission ratios and torques

Selection and ordering data

Gearbox							Adapter											Article No.						
<i>i</i>	<i>n</i> ₂	<i>T</i> _{2N}	<i>F</i> _{R2}	ϕ ¹⁾	<i>J</i> _G	<i>R</i> _{ex}	K4	63	71	80	90	100	112	132	160	180	200	225	250				(Article No. supplement → below)	
-	rpm	Nm	N	'	10 ⁻⁴	-	K2			80	90	100	112	132	160	180	200	225	250	280	315			
							KQ		703	704	706		708	710										
							K8						808	810		813		816		818	822			
							K5	56		140	180		210	250			280	320	360					
							K3	56		140	180		210	250			280	320	360					
Z.29																								
41.40	35	140	3 710	23	0.04	207/5	✓	✓																2KJ3102 - ■ ■ A 0 ■ - 0 ■ A2
36.72	39	140	3 690	21	0.05	918/25	✓	✓	✓	✓														2KJ3102 - ■ ■ A 0 ■ - 0 ■ X1
31.86	46	140	3 350	21	0.06	1593/50	✓	✓	✓	✓														2KJ3102 - ■ ■ A 0 ■ - 0 ■ W1
28.96	50	140	3 120	21	0.07	1593/55	✓	✓	✓	✓														2KJ3102 - ■ ■ A 0 ■ - 0 ■ V1
24.84	58	140	2 780	21	0.09	621/25	✓	✓	✓	✓														2KJ3102 - ■ ■ A 0 ■ - 0 ■ U1
22.58	64	140	2 580	21	0.11	1242/55	✓	✓	✓	✓														2KJ3102 - ■ ■ A 0 ■ - 0 ■ T1
19.80	73	140	2 310	21	0.13	99/5	✓	✓	✓	✓	✓													2KJ3102 - ■ ■ A 0 ■ - 0 ■ S1
17.67	82	140	2 090	22	0.15	972/55	✓	✓	✓	✓	✓													2KJ3102 - ■ ■ A 0 ■ - 0 ■ R1
15.75	92	140	1 870	22	0.18	63/4	✓	✓	✓	✓	✓													2KJ3102 - ■ ■ A 0 ■ - 0 ■ Q1
14.54	100	120	2 250	22	0.23	189/13	✓	✓	✓	✓	✓													2KJ3102 - ■ ■ A 0 ■ - 0 ■ P1
12.73	114	140	1 480	22	0.26	891/70	✓	✓	✓	✓	✓													2KJ3102 - ■ ■ A 0 ■ - 0 ■ N1
11.16	130	140	1 260	22	0.27	279/25	✓	✓	✓	✓	✓													2KJ3102 - ■ ■ A 0 ■ - 0 ■ M1
10.12	143	140	1 100	22	0.34	81/8	✓	✓	✓	✓	✓													2KJ3102 - ■ ■ A 0 ■ - 0 ■ L1
9.53	152	140	1 010	22	0.40	162/17	✓	✓	✓	✓	✓													2KJ3102 - ■ ■ A 0 ■ - 0 ■ K1
8.40	173	138	870	22	0.45	42/5	✓	✓	✓	✓	✓													2KJ3102 - ■ ■ A 0 ■ - 0 ■ J1
7.29	199	130	870	22	0.60	729/100	✓	✓	✓	✓	✓													2KJ3102 - ■ ■ A 0 ■ - 0 ■ H1
6.92	210	75	1 910	30	0.29	90/13	✓	✓	✓	✓	✓													2KJ3102 - ■ ■ A 0 ■ - 0 ■ G1
6.06	239	100	955	31	0.34	297/49	✓	✓	✓	✓	✓													2KJ3102 - ■ ■ A 0 ■ - 0 ■ F1
5.31	273	91	1 060	32	0.37	186/35	✓	✓	✓	✓	✓													2KJ3102 - ■ ■ A 0 ■ - 0 ■ E1
4.82	301	86	1 090	32	0.46	135/28	✓	✓	✓	✓	✓													2KJ3102 - ■ ■ A 0 ■ - 0 ■ D1
4.54	319	84	1 070	32	0.54	540/119	✓	✓	✓	✓	✓													2KJ3102 - ■ ■ A 0 ■ - 0 ■ C1
4.00	362	76	1 170	31	0.63	4/1	✓	✓	✓	✓	✓													2KJ3102 - ■ ■ A 0 ■ - 0 ■ B1
3.47	418	70	1 240	32	0.84	243/70	✓	✓	✓	✓	✓													2KJ3102 - ■ ■ A 0 ■ - 0 ■ A1

1) Only in conjunction with reduced-backlash version

Article No. supplement		1 or 9																						
Shaft design	→ Page 9/39																							
Adapter size		K4	B	C	D	E	F	G	H	J	K	L	M	N									4	
		K2			D	E	F	G	H	J	K	L	M	N	P	Q								2
		KQ	A	B	C			D	E															7
		K8						A	B		C		D		E	F								8
		K5	A	B	C			D	E		F	G	H											5
	K3	A		B	C		D	E		F	G	H											3	
Adapter type																								
Gearbox mounting type	→ Page 9/34	A, B, F or H																						

Selection and ordering data

Gearbox							Adapter											Article No.						
<i>i</i>	<i>n</i> ₂	<i>T</i> _{2N}	<i>F</i> _{R2}	ϕ ¹⁾	<i>J</i> _G	<i>R</i> _{ex}	K4	63	71	80	90	100	112	132	160	180	200	225	250				(Article No. supplement → below)	
-	rpm	Nm	N	'	10 ⁻⁴	-	K2			80	90	100	112	132	160	180	200	225	250	280	315			
							KQ	703	704	706		708	710											
							K8					808	810		813		816			818	822			
							K5	56		140	180		210	250		280	320	360						
							K3	56		140	180		210	250		280	320	360						
D.39																								
235.29	6.2	200	4 370	10	0.03	179998/765	✓	✓															2KJ3203 - ■ ■ A 0 ■ - 0 ■ R1	
208.69	6.9	200	4 370	10	0.05	15652/75	✓	✓																2KJ3203 - ■ ■ A 0 ■ - 0 ■ Q1
181.07	8	200	4 370	10	0.05	230867/1275	✓	✓																2KJ3203 - ■ ■ A 0 ■ - 0 ■ P1
164.61	8.8	200	4 370	10	0.07	461734/2805	✓	✓	✓	✓														2KJ3203 - ■ ■ A 0 ■ - 0 ■ N1
141.17	10	200	4 370	10	0.08	179998/1275	✓	✓	✓	✓														2KJ3203 - ■ ■ A 0 ■ - 0 ■ M1
128.34	11	200	4 370	10	0.10	359996/2805	✓	✓	✓	✓														2KJ3203 - ■ ■ A 0 ■ - 0 ■ L1
112.53	13	200	4 370	10	0.12	86086/765	✓	✓	✓	✓														2KJ3203 - ■ ■ A 0 ■ - 0 ■ K1
100.44	14	200	4 370	10	0.15	93912/935	✓	✓	✓	✓	✓	✓	✓											2KJ3203 - ■ ■ A 0 ■ - 0 ■ J1
89.51	16	200	4 370	11	0.17	27391/306	✓	✓	✓	✓	✓	✓	✓	✓										2KJ3203 - ■ ■ A 0 ■ - 0 ■ H1
82.63	18	200	4 370	11	0.21	4214/51	✓	✓	✓	✓	✓	✓	✓	✓										2KJ3203 - ■ ■ A 0 ■ - 0 ■ G1
72.34	20	200	4 370	11	0.25	6149/85	✓	✓	✓	✓	✓	✓	✓	✓										2KJ3203 - ■ ■ A 0 ■ - 0 ■ F1
63.43	23	200	4 370	11	0.23	242606/3825	✓	✓	✓	✓	✓	✓	✓	✓										2KJ3203 - ■ ■ A 0 ■ - 0 ■ E1
57.54	25	200	4 370	11	0.33	3913/68	✓	✓	✓	✓	✓	✓	✓	✓										2KJ3203 - ■ ■ A 0 ■ - 0 ■ D1
54.16	27	200	4 370	11	0.39	15652/289	✓	✓	✓	✓	✓	✓	✓	✓										2KJ3203 - ■ ■ A 0 ■ - 0 ■ C1
47.74	30	200	4 370	11	0.43	109564/2295	✓	✓	✓	✓	✓	✓	✓	✓										2KJ3203 - ■ ■ A 0 ■ - 0 ■ B1
41.43	35	200	3 940	11	0.58	35217/850	✓	✓	✓	✓	✓	✓	✓	✓										2KJ3203 - ■ ■ A 0 ■ - 0 ■ A1

1) Only in conjunction with reduced-backlash version

Article No. supplement		1 or 9																					
Shaft design	→ Page 9/39																						
Adapter size		K4	B	C	D	E	F	G	H	J	K	L	M	N									4
		K2			D	E	F	G	H	J	K	L	M	N	P	Q							2
		KQ		A	B	C		D	E														7
		K8						A	B		C		D		E	F							8
		K5		A		B	C		D	E		F	G	H									5
		K3		A		B	C		D	E		F	G	H									3
Adapter type																							
Gearbox mounting type	→ Page 9/34		A, B, F or H																				

SIMOGEAR Gearboxes

Helical gearboxes

Transmission ratios and torques

Selection and ordering data

Gearbox							Adapter											Article No.						
i	n_2	T_{2N}	F_{R2}	$\phi^{1)}$	J_G	R_{ex}	K4	63	71	80	90	100	112	132	160	180	200	225	250				(Article No. supplement → below)	
-	rpm	Nm	N	'	10^{-4}	-	K2			80	90	100	112	132	160	180	200	225	250	280	315			
							KQ	703	704	706		708	710											
							K8					808	810		813		816			818	822			
							K5	56		140	180		210	250		280	320	360						
							K3	56		140	180		210	250		280	320	360						
Z.39																								
55.95	26	200	4 370	9	0.06	7553/135	✓	✓															2KJ3103 - ■ ■ A 0 ■ - 0 ■ A2	
49.75	29	200	4 370	10	0.07	3731/75	✓	✓	✓	✓													2KJ3103 - ■ ■ A 0 ■ - 0 ■ X1	
43.68	33	200	4 100	10	0.08	1092/25	✓	✓	✓	✓													2KJ3103 - ■ ■ A 0 ■ - 0 ■ W1	
39.71	37	200	3 810	10	0.10	2184/55	✓	✓	✓	✓													2KJ3103 - ■ ■ A 0 ■ - 0 ■ V1	
33.97	43	200	3 360	10	0.12	2548/75	✓	✓	✓	✓													2KJ3103 - ■ ■ A 0 ■ - 0 ■ U1	
30.88	47	200	3 100	10	0.14	5096/165	✓	✓	✓	✓													2KJ3103 - ■ ■ A 0 ■ - 0 ■ T1	
27.30	53	200	2 780	10	0.17	273/10	✓	✓	✓	✓	✓	✓	✓										2KJ3103 - ■ ■ A 0 ■ - 0 ■ S1	
24.82	58	200	2 530	10	0.22	273/11	✓	✓	✓	✓	✓	✓	✓										2KJ3103 - ■ ■ A 0 ■ - 0 ■ R1	
21.74	67	200	2 210	10	0.25	3913/180	✓	✓	✓	✓	✓	✓	✓										2KJ3103 - ■ ■ A 0 ■ - 0 ■ Q1	
20.07	72	200	2 020	10	0.31	301/15	✓	✓	✓	✓	✓	✓	✓										2KJ3103 - ■ ■ A 0 ■ - 0 ■ P1	
17.77	82	200	1 740	10	0.36	533/30	✓	✓	✓	✓	✓	✓	✓										2KJ3103 - ■ ■ A 0 ■ - 0 ■ N1	
14.79	98	193	1 510	11	0.47	1183/80	✓	✓	✓	✓	✓	✓	✓										2KJ3103 - ■ ■ A 0 ■ - 0 ■ M1	
13.92	104	189	1 490	11	0.55	1183/85	✓	✓	✓	✓	✓	✓	✓										2KJ3103 - ■ ■ A 0 ■ - 0 ■ L1	
12.47	116	180	1 490	11	0.60	3367/270	✓	✓	✓	✓	✓	✓	✓										2KJ3103 - ■ ■ A 0 ■ - 0 ■ K1	
10.62	137	169	1 450	11	0.78	637/60	✓	✓	✓	✓	✓	✓	✓										2KJ3103 - ■ ■ A 0 ■ - 0 ■ J1	
9.10	159	158	1 440	11	1.02	91/10			✓	✓	✓	✓	✓										2KJ3103 - ■ ■ A 0 ■ - 0 ■ H1	
7.84	185	148	1 430	17	1.30	2821/360			✓	✓	✓	✓	✓										2KJ3103 - ■ ■ A 0 ■ - 0 ■ G1	
6.46	224	146	235	17	0.57	2379/368	✓	✓	✓	✓	✓	✓	✓										2KJ3103 - ■ ■ A 0 ■ - 0 ■ F1	
6.08	238	147	110	17	0.66	2379/391	✓	✓	✓	✓	✓	✓	✓										2KJ3103 - ■ ■ A 0 ■ - 0 ■ E1	
5.45	266	140	160	17	0.74	2257/414	✓	✓	✓	✓	✓	✓	✓										2KJ3103 - ■ ■ A 0 ■ - 0 ■ D1	
4.64	312	130	475	18	0.97	427/92	✓	✓	✓	✓	✓	✓	✓										2KJ3103 - ■ ■ A 0 ■ - 0 ■ C1	
3.98	364	121	805	18	1.28	183/46			✓	✓	✓	✓	✓										2KJ3103 - ■ ■ A 0 ■ - 0 ■ B1	
3.43	423	112	1 060	19	1.65	1891/552			✓	✓	✓	✓	✓										2KJ3103 - ■ ■ A 0 ■ - 0 ■ A1	

1) Only in conjunction with reduced-backlash version

Article No. supplement		1 or 9																					
Shaft design	→ Page 9/39																						
Adapter size		K4	B	C	D	E	F	G	H	J	K	L	M	N									4
		K2			D	E	F	G	H	J	K	L	M	N	P	Q							2
		KQ	A	B	C			D	E														7
		K8						A	B		C		D		E	F							8
Adapter type		K5	A		B	C		D	E		F	G	H										5
Gearbox mounting type	→ Page 9/34	K3	A		B	C		D	E		F	G	H										3

Selection and ordering data

Gearbox							Adapter										Article No.					
<i>i</i>	<i>n</i> ₂	<i>T</i> _{2N}	<i>F</i> _{R2}	ϕ ¹⁾	<i>J</i> _G	<i>R</i> _{ex}	K4	63	71	80	90	100	112	132	160	180	200	225	250			(Article No. supplement → below)
-	rpm	Nm	N	'	10 ⁻⁴	-	K2			80	90	100	112	132	160	180	200	225	250	280	315	
							KQ	703	704	706		708	710									
							K8					808	810		813		816			818	822	
							K5	56		140	180		210	250		280	320	360				
							K3	56		140	180		210	250		280	320	360				
D.49																						
280.89	5.2	320	5 780	9	0.06	60673/216	✓	✓														2KJ3204 - ■ ■ A 0 ■ - 0 ■ S1
249.76	5.8	320	5 780	9	0.07	29971/120	✓	✓														2KJ3204 - ■ ■ A 0 ■ - 0 ■ R1
219.30	6.6	320	5 780	9	0.08	2193/10	✓	✓														2KJ3204 - ■ ■ A 0 ■ - 0 ■ Q1
199.36	7.3	320	5 780	9	0.10	2193/11	✓	✓	✓	✓												2KJ3204 - ■ ■ A 0 ■ - 0 ■ P1
170.57	8.5	320	5 780	9	0.12	5117/30	✓	✓	✓	✓												2KJ3204 - ■ ■ A 0 ■ - 0 ■ N1
155.06	9.4	320	5 780	9	0.14	5117/33	✓	✓	✓	✓												2KJ3204 - ■ ■ A 0 ■ - 0 ■ M1
137.06	11	320	5 780	9	0.17	2193/16	✓	✓	✓	✓	✓	✓	✓									2KJ3204 - ■ ■ A 0 ■ - 0 ■ L1
124.60	12	320	5 780	9	0.22	10965/88	✓	✓	✓	✓	✓	✓	✓									2KJ3204 - ■ ■ A 0 ■ - 0 ■ K1
109.14	13	320	5 780	9	0.25	31433/288	✓	✓	✓	✓	✓	✓	✓									2KJ3204 - ■ ■ A 0 ■ - 0 ■ J1
100.75	14	320	5 780	9	0.31	31433/312	✓	✓	✓	✓	✓	✓	✓									2KJ3204 - ■ ■ A 0 ■ - 0 ■ H1
89.20	16	320	5 780	9	0.37	29971/336	✓	✓	✓	✓	✓	✓	✓	✓								2KJ3204 - ■ ■ A 0 ■ - 0 ■ G1
74.24	20	320	5 780	9	0.50	9503/128	✓	✓	✓	✓	✓	✓	✓	✓								2KJ3204 - ■ ■ A 0 ■ - 0 ■ F1
69.88	21	320	5 780	9	0.58	559/8	✓	✓	✓	✓	✓	✓	✓	✓								2KJ3204 - ■ ■ A 0 ■ - 0 ■ E1
62.61	23	320	5 780	9	0.65	27047/432	✓	✓	✓	✓	✓	✓	✓	✓								2KJ3204 - ■ ■ A 0 ■ - 0 ■ D1
53.30	27	320	5 780	9	0.85	5117/96	✓	✓	✓	✓	✓	✓	✓	✓								2KJ3204 - ■ ■ A 0 ■ - 0 ■ C1
45.69	32	320	5 780	9	1.12	731/16			✓	✓	✓	✓	✓	✓								2KJ3204 - ■ ■ A 0 ■ - 0 ■ B1
39.34	37	320	5 570	9	1.43	22661/576			✓	✓	✓	✓	✓	✓								2KJ3204 - ■ ■ A 0 ■ - 0 ■ A1

1) Only in conjunction with reduced-backlash version

Article No. supplement		1 or 9																				
Shaft design	→ Page 9/39																					
Adapter size		K4	B	C	D	E	F	G	H	J	K	L	M	N								4
		K2			D	E	F	G	H	J	K	L	M	N	P	Q						2
		KQ		A	B	C		D	E													7
		K8						A	B	C		D		E	F							8
		K5		A		B	C		D	E		F	G	H								5
		K3		A		B	C		D	E		F	G	H								3
Adapter type																						
Gearbox mounting type	→ Page 9/34	A, B, F or H																				



SIMOGEAR Gearboxes

Helical gearboxes

Transmission ratios and torques

Selection and ordering data

Gearbox							Adapter												Article No.					
<i>i</i>	<i>n</i> ₂	<i>T</i> _{2N}	<i>F</i> _{R2}	ϕ ¹⁾	<i>J</i> _G	<i>R</i> _{ex}	K4	63	71	80	90	100	112	132	160	180	200	225	250					(Article No. supplement → below)
-	rpm	Nm	N	'	10 ⁻⁴	-	K2			80	90	100	112	132	160	180	200	225	250	280	315			
							KQ		703	704	706		708	710										
							K8						808	810		813		816			818	822		
							K5	56			140	180		210	250		280	320	360					
							K3	56			140	180		210	250		280	320	360					

Z.49

52.14	28	320	5 900	8	0.17	4171/80	✓	✓	✓	✓														2KJ3104 - ■ ■ A 0 ■ - 0 ■ B2
47.40	31	320	5 780	8	0.21	4171/88	✓	✓	✓	✓														2KJ3104 - ■ ■ A 0 ■ - 0 ■ A2
40.31	36	320	5 680	8	0.25	645/16	✓	✓	✓	✓														2KJ3104 - ■ ■ A 0 ■ - 0 ■ X1
36.65	40	320	5 250	8	0.31	3225/88	✓	✓	✓	✓														2KJ3104 - ■ ■ A 0 ■ - 0 ■ W1
32.70	44	320	5 540	9	0.36	3139/96	✓	✓	✓	✓	✓	✓												2KJ3104 - ■ ■ A 0 ■ - 0 ■ V1
29.32	49	320	5 300	9	0.43	645/22	✓	✓	✓	✓	✓	✓												2KJ3104 - ■ ■ A 0 ■ - 0 ■ U1
26.43	55	320	5 070	9	0.50	2537/96	✓	✓	✓	✓	✓	✓												2KJ3104 - ■ ■ A 0 ■ - 0 ■ T1
24.39	59	320	4 910	9	0.59	2537/104	✓	✓	✓	✓	✓	✓												2KJ3104 - ■ ■ A 0 ■ - 0 ■ S1
22.27	65	320	4 720	9	0.71	1247/56	✓	✓	✓	✓	✓	✓	✓											2KJ3104 - ■ ■ A 0 ■ - 0 ■ R1
18.48	78	320	4 360	9	0.90	2365/128	✓	✓	✓	✓	✓	✓	✓											2KJ3104 - ■ ■ A 0 ■ - 0 ■ Q1
17.39	83	320	4 250	9	1.03	2365/136	✓	✓	✓	✓	✓	✓	✓											2KJ3104 - ■ ■ A 0 ■ - 0 ■ P1
16.42	88	320	4 140	9	1.17	2365/144	✓	✓	✓	✓	✓	✓	✓											2KJ3104 - ■ ■ A 0 ■ - 0 ■ N1
13.98	104	320	3 860	9	1.44	559/40	✓	✓	✓	✓	✓	✓	✓											2KJ3104 - ■ ■ A 0 ■ - 0 ■ M1
11.97	121	320	3 600	9	1.76	2107/176			✓	✓	✓	✓	✓											2KJ3104 - ■ ■ A 0 ■ - 0 ■ L1
10.53	138	320	3 400	9	2.10	2021/192			✓	✓	✓	✓	✓											2KJ3104 - ■ ■ A 0 ■ - 0 ■ K1
8.88	163	320	3 140	10	2.70	817/92			✓	✓	✓	✓	✓											2KJ3104 - ■ ■ A 0 ■ - 0 ■ J1
7.74	187	320	3 100	10	3.60	387/50			✓	✓	✓	✓	✓											2KJ3104 - ■ ■ A 0 ■ - 0 ■ H1
7.64	190	295	3 000	14	1.18	649/85	✓	✓	✓	✓	✓	✓	✓											2KJ3104 - ■ ■ A 0 ■ - 0 ■ G1
7.21	201	290	2 990	14	1.34	649/90	✓	✓	✓	✓	✓	✓	✓											2KJ3104 - ■ ■ A 0 ■ - 0 ■ F1
6.14	236	265	2 940	14	1.67	767/125	✓	✓	✓	✓	✓	✓	✓											2KJ3104 - ■ ■ A 0 ■ - 0 ■ E1
5.26	276	245	2 880	15	2.10	2891/550			✓	✓	✓	✓	✓											2KJ3104 - ■ ■ A 0 ■ - 0 ■ D1
4.62	314	225	2 820	15	2.60	2773/600			✓	✓	✓	✓	✓											2KJ3104 - ■ ■ A 0 ■ - 0 ■ C1
3.90	372	205	2 740	16	3.30	2242/575			✓	✓	✓	✓	✓											2KJ3104 - ■ ■ A 0 ■ - 0 ■ B1
3.40	426	191	2 200	17	4.40	2124/625			✓	✓	✓	✓	✓											2KJ3104 - ■ ■ A 0 ■ - 0 ■ A1

1) Only in conjunction with reduced-backlash version

Article No. supplement

Shaft design	→ Page 9/39	1 or 9																								
Adapter size	K4	B	C	D	E	F	G	H	J	K	L	M	N												4	
	K2			D	E	F	G	H	J	K	L	M	N	P	Q											2
	KQ	A	B	C			D	E																		7
	K8						A	B		C		D		E	F											8
	K5	A		B	C			D	E		F	G	H													5
K3	A		B	C			D	E		F	G	H													3	
Adapter type																										
Gearbox mounting type	→ Page 9/34	A, B, F or H																								

Selection and ordering data

Gearbox							Adapter											Article No.						
<i>i</i>	<i>n</i> ₂	<i>T</i> _{2N}	<i>F</i> _{R2}	ϕ ¹⁾	<i>J</i> _G	<i>R</i> _{ex}	K4	63	71	80	90	100	112	132	160	180	200	225	250				(Article No. supplement → below)	
-	rpm	Nm	N	'	10 ⁻⁴	-	K2			80	90	100	112	132	160	180	200	225	250	280	315			
							KQ	703	704	706			708	710										
							K8						808	810		813		816			818	822		
							K5	56		140	180			210	250		280	320	360					
							K3	56		140	180			210	250		280	320	360					
D.59																								
307.02	4.7	450	7 660	8	0.06	66317/216	✓	✓																2KJ3205 - ■ ■ A 0 ■ - 0 ■ S1
272.99	5.3	450	7 660	8	0.07	32759/120	✓	✓	✓	✓														2KJ3205 - ■ ■ A 0 ■ - 0 ■ R1
239.70	6.0	450	7 660	8	0.08	2397/10	✓	✓	✓	✓														2KJ3205 - ■ ■ A 0 ■ - 0 ■ Q1
217.91	6.7	450	7 660	8	0.10	2397/11	✓	✓	✓	✓														2KJ3205 - ■ ■ A 0 ■ - 0 ■ P1
186.43	7.8	450	7 660	8	0.12	5593/30	✓	✓	✓	✓														2KJ3205 - ■ ■ A 0 ■ - 0 ■ N1
169.48	8.6	450	7 660	8	0.14	5593/33	✓	✓	✓	✓														2KJ3205 - ■ ■ A 0 ■ - 0 ■ M1
149.81	9.7	450	7 660	8	0.17	2397/16	✓	✓	✓	✓	✓	✓	✓	✓										2KJ3205 - ■ ■ A 0 ■ - 0 ■ L1
136.19	11	450	7 660	8	0.22	11985/88	✓	✓	✓	✓	✓	✓	✓	✓										2KJ3205 - ■ ■ A 0 ■ - 0 ■ K1
119.30	12	450	7 660	8	0.26	34357/288	✓	✓	✓	✓	✓	✓	✓	✓										2KJ3205 - ■ ■ A 0 ■ - 0 ■ J1
110.12	13	450	7 660	8	0.31	34357/312	✓	✓	✓	✓	✓	✓	✓	✓										2KJ3205 - ■ ■ A 0 ■ - 0 ■ H1
97.50	15	450	7 660	8	0.37	32759/336	✓	✓	✓	✓	✓	✓	✓	✓										2KJ3205 - ■ ■ A 0 ■ - 0 ■ G1
81.15	18	450	7 660	8	0.50	10387/128	✓	✓	✓	✓	✓	✓	✓	✓										2KJ3205 - ■ ■ A 0 ■ - 0 ■ F1
76.38	19	450	7 660	8	0.59	611/8	✓	✓	✓	✓	✓	✓	✓	✓										2KJ3205 - ■ ■ A 0 ■ - 0 ■ E1
68.43	21	450	7 660	8	0.65	29563/432	✓	✓	✓	✓	✓	✓	✓	✓										2KJ3205 - ■ ■ A 0 ■ - 0 ■ D1
58.26	25	450	7 660	8	0.85	5593/96	✓	✓	✓	✓	✓	✓	✓	✓										2KJ3205 - ■ ■ A 0 ■ - 0 ■ C1
49.94	29	450	7 660	8	1.12	799/16			✓	✓	✓	✓	✓	✓										2KJ3205 - ■ ■ A 0 ■ - 0 ■ B1
43.00	34	450	7 250	8	1.44	24769/576			✓	✓	✓	✓	✓	✓										2KJ3205 - ■ ■ A 0 ■ - 0 ■ A1

1) Only in conjunction with reduced-backlash version

Article No. supplement		1 or 9																						
Shaft design	→ Page 9/39																							
Adapter size		K4	B	C	D	E	F	G	H	J	K	L	M	N										4
		K2			D	E	F	G	H	J	K	L	M	N	P	Q								2
		KQ		A	B	C		D	E															7
		K8						A	B		C		D		E	F								8
		K5		A		B	C		D	E		F	G	H										5
		K3		A		B	C		D	E		F	G	H										3
Adapter type																								
Gearbox mounting type	→ Page 9/34		A, B, F or H																					

SIMOGEAR Gearboxes

Helical gearboxes

Transmission ratios and torques

Selection and ordering data

Gearbox							Adapter											Article No.					
i	n_2	T_{2N}	F_{R2}	ϕ ¹⁾	J_G	R_{ex}	K4	63	71	80	90	100	112	132	160	180	200	225	250				(Article No. supplement → below)
-	rpm	Nm	N	'	10^{-4}	-	K2			80	90	100	112	132	160	180	200	225	250	280	315		
							KQ	703	704	706		708	710										
							K8					808	810		813		816			818	822		
							K5	56		140	180		210	250		280	320	360					
							K3	56		140	180		210	250		280	320	360					

Z.59

56.99	25	450	7 660	8	0.18	4559/80	✓	✓	✓	✓													2KJ3105 - ■ ■ A 0 ■ - 0 ■ A2
51.81	28	450	7 660	8	0.21	4559/88	✓	✓	✓	✓													2KJ3105 - ■ ■ A 0 ■ - 0 ■ X1
44.06	33	450	7 330	8	0.26	705/16	✓	✓	✓	✓													2KJ3105 - ■ ■ A 0 ■ - 0 ■ W1
40.06	36	450	7 040	8	0.32	3525/88	✓	✓	✓	✓													2KJ3105 - ■ ■ A 0 ■ - 0 ■ V1
35.74	41	450	6 710	8	0.37	3431/96	✓	✓	✓	✓	✓	✓											2KJ3105 - ■ ■ A 0 ■ - 0 ■ U1
32.05	45	450	6 210	8	0.44	705/22	✓	✓	✓	✓	✓	✓											2KJ3105 - ■ ■ A 0 ■ - 0 ■ T1
28.89	50	450	5 720	8	0.52	2773/96	✓	✓	✓	✓	✓	✓											2KJ3105 - ■ ■ A 0 ■ - 0 ■ S1
26.66	54	450	5 360	8	0.62	2773/104	✓	✓	✓	✓	✓	✓											2KJ3105 - ■ ■ A 0 ■ - 0 ■ R1
24.34	60	450	4 960	8	0.73	1363/56	✓	✓	✓	✓	✓	✓	✓										2KJ3105 - ■ ■ A 0 ■ - 0 ■ Q1
20.20	72	450	5 240	8	0.94	2585/128	✓	✓	✓	✓	✓	✓	✓										2KJ3105 - ■ ■ A 0 ■ - 0 ■ P1
19.01	76	450	5 100	8	1.08	2585/136	✓	✓	✓	✓	✓	✓	✓										2KJ3105 - ■ ■ A 0 ■ - 0 ■ N1
17.95	81	450	4 970	8	1.23	2585/144	✓	✓	✓	✓	✓	✓	✓										2KJ3105 - ■ ■ A 0 ■ - 0 ■ M1
15.27	95	450	4 620	8	1.51	611/40	✓	✓	✓	✓	✓	✓	✓										2KJ3105 - ■ ■ A 0 ■ - 0 ■ L1
13.09	111	450	4 300	8	1.85	2303/176			✓	✓	✓	✓	✓										2KJ3105 - ■ ■ A 0 ■ - 0 ■ K1
11.51	126	450	4 040	9	2.30	2209/192			✓	✓	✓	✓	✓										2KJ3105 - ■ ■ A 0 ■ - 0 ■ J1
9.71	149	450	3 720	9	2.90	893/92			✓	✓	✓	✓	✓										2KJ3105 - ■ ■ A 0 ■ - 0 ■ H1
8.46	171	450	3 600	9	3.90	423/50			✓	✓	✓	✓	✓										2KJ3105 - ■ ■ A 0 ■ - 0 ■ G1
8.07	180	410	3 510	13	1.45	121/15	✓	✓	✓	✓	✓	✓	✓										2KJ3105 - ■ ■ A 0 ■ - 0 ■ F1
6.86	211	410	3 480	13	1.81	858/125	✓	✓	✓	✓	✓	✓	✓										2KJ3105 - ■ ■ A 0 ■ - 0 ■ E1
5.88	247	410	3 440	13	2.30	147/25			✓	✓	✓	✓	✓										2KJ3105 - ■ ■ A 0 ■ - 0 ■ D1
5.17	280	410	2 190	14	2.80	517/100			✓	✓	✓	✓	✓										2KJ3105 - ■ ■ A 0 ■ - 0 ■ C1
4.36	333	405	2 630	14	3.60	2508/575			✓	✓	✓	✓	✓										2KJ3105 - ■ ■ A 0 ■ - 0 ■ B1
3.80	382	405	2 900	16	4.90	2376/625			✓	✓	✓	✓	✓										2KJ3105 - ■ ■ A 0 ■ - 0 ■ A1

1) Only in conjunction with reduced-backlash version

Article No. supplement		1 or 9																					
Shaft design	→ Page 9/39																						
Adapter size		K4	B	C	D	E	F	G	H	J	K	L	M	N									4
		K2			D	E	F	G	H	J	K	L	M	N	P	Q							2
		KQ	A	B	C			D	E														7
		K8						A	B		C		D		E	F							8
		K5	A		B	C		D	E		F	G	H										5
		K3	A		B	C		D	E		F	G	H										3
Adapter type																							
Gearbox mounting type	→ Page 9/34																						

Selection and ordering data

Gearbox							Adapter											Article No.				
<i>i</i>	<i>n</i> ₂	<i>T</i> _{2N}	<i>F</i> _{R2}	ϕ ¹⁾	<i>J</i> _G	<i>R</i> _{ex}	K4	63	71	80	90	100	112	132	160	180	200	225	250			(Article No. supplement → below)
-	rpm	Nm	N	'	10 ⁻⁴	-	K2			80	90	100	112	132	160	180	200	225	250	280	315	
							KQ	703	704	706		708	710									
							K8					808	810		813		816			818	822	
							K5	56		140	180		210	250		280	320	360				
							K3	56		140	180		210	250		280	320	360				
D.69																						
328.49	4.4	600	11 000	7	0.06	62084/189	✓	✓														2KJ3206 - ■ ■ A 0 ■ - 0 ■ S1
292.08	5.0	600	11 000	7	0.07	30668/105	✓	✓	✓	✓												2KJ3206 - ■ ■ A 0 ■ - 0 ■ R1
256.46	5.7	600	11 000	7	0.08	8976/35	✓	✓	✓	✓												2KJ3206 - ■ ■ A 0 ■ - 0 ■ Q1
233.14	6.2	600	11 000	7	0.10	1632/7	✓	✓	✓	✓												2KJ3206 - ■ ■ A 0 ■ - 0 ■ P1
199.47	7.3	600	11 000	7	0.12	2992/15	✓	✓	✓	✓												2KJ3206 - ■ ■ A 0 ■ - 0 ■ N1
181.33	8	600	11 000	7	0.14	544/3	✓	✓	✓	✓												2KJ3206 - ■ ■ A 0 ■ - 0 ■ M1
160.29	9	600	11 000	7	0.17	1122/7	✓	✓	✓	✓	✓	✓	✓									2KJ3206 - ■ ■ A 0 ■ - 0 ■ L1
145.71	10	600	11 000	7	0.22	1020/7	✓	✓	✓	✓	✓	✓	✓									2KJ3206 - ■ ■ A 0 ■ - 0 ■ K1
127.63	11	600	11 000	7	0.26	8041/63	✓	✓	✓	✓	✓	✓	✓									2KJ3206 - ■ ■ A 0 ■ - 0 ■ J1
117.82	12	600	11 000	7	0.31	32164/273	✓	✓	✓	✓	✓	✓	✓									2KJ3206 - ■ ■ A 0 ■ - 0 ■ H1
104.31	14	600	11 000	7	0.37	15334/147	✓	✓	✓	✓	✓	✓	✓	✓								2KJ3206 - ■ ■ A 0 ■ - 0 ■ G1
86.82	17	600	11 000	7	0.50	2431/28	✓	✓	✓	✓	✓	✓	✓	✓								2KJ3206 - ■ ■ A 0 ■ - 0 ■ F1
81.71	18	600	11 000	7	0.59	572/7	✓	✓	✓	✓	✓	✓	✓	✓								2KJ3206 - ■ ■ A 0 ■ - 0 ■ E1
73.22	20	600	11 000	7	0.66	13838/189	✓	✓	✓	✓	✓	✓	✓	✓								2KJ3206 - ■ ■ A 0 ■ - 0 ■ D1
62.33	23	600	11 000	8	0.86	187/3			✓	✓	✓	✓	✓	✓								2KJ3206 - ■ ■ A 0 ■ - 0 ■ C1
53.43	27	600	11 000	8	1.14	374/7			✓	✓	✓	✓	✓	✓								2KJ3206 - ■ ■ A 0 ■ - 0 ■ B1
46.01	32	600	11 000	8	1.46	5797/126			✓	✓	✓	✓	✓	✓								2KJ3206 - ■ ■ A 0 ■ - 0 ■ A1

1) Only in conjunction with reduced-backlash version

Article No. supplement		1 or 9																				
Shaft design	→ Page 9/39																					
Adapter size		K4	B	C	D	E	F	G	H	J	K	L	M	N								4
		K2			D	E	F	G	H	J	K	L	M	N	P	Q						2
		KQ		A	B	C		D	E													7
		K8						A	B	C		D		E	F							8
		K5		A		B	C		D	E		F	G	H								5
		K3		A		B	C		D	E		F	G	H								3
Adapter type																						
Gearbox mounting type	→ Page 9/34	A, B, F or H																				

SIMOGEAR Gearboxes

Helical gearboxes

Transmission ratios and torques

Selection and ordering data

Gearbox							Adapter											Article No.						
<i>i</i>	<i>n</i> ₂	<i>T</i> _{2N}	<i>F</i> _{R2}	ϕ ¹⁾	<i>J</i> _G	<i>R</i> _{ex}	K4	63	71	80	90	100	112	132	160	180	200	225	250				(Article No. supplement → below)	
-	rpm	Nm	N	'	10 ⁻⁴	-	K2			80	90	100	112	132	160	180	200	225	250	280	315			
							KQ	703	704	706		708	710											
							K8					808	810		813		816			818	822			
							K5	56		140	180		210	250		280	320	360						
							K3	56		140	180		210	250		280	320	360						
Z.69																								
60.97	24	600	11 000	8	0.18	2134/35	✓	✓	✓	✓													2KJ3106 - ■ ■ A 0 ■ - 0 ■ A2	
55.43	26	600	11 000	8	0.22	388/7	✓	✓	✓	✓													2KJ3106 - ■ ■ A 0 ■ - 0 ■ X1	
47.14	31	600	11 000	8	0.28	330/7	✓	✓	✓	✓													2KJ3106 - ■ ■ A 0 ■ - 0 ■ W1	
42.86	34	600	11 000	8	0.34	300/7	✓	✓	✓	✓													2KJ3106 - ■ ■ A 0 ■ - 0 ■ V1	
38.24	38	600	11 000	8	0.39	803/21	✓	✓	✓	✓	✓	✓											2KJ3106 - ■ ■ A 0 ■ - 0 ■ U1	
34.29	42	600	11 000	8	0.47	240/7	✓	✓	✓	✓	✓	✓											2KJ3106 - ■ ■ A 0 ■ - 0 ■ T1	
30.90	47	600	10 500	8	0.56	649/21	✓	✓	✓	✓	✓	✓											2KJ3106 - ■ ■ A 0 ■ - 0 ■ S1	
28.53	51	600	9 910	8	0.66	2596/91	✓	✓	✓	✓	✓	✓											2KJ3106 - ■ ■ A 0 ■ - 0 ■ R1	
26.04	56	600	9 250	8	0.79	1276/49	✓	✓	✓	✓	✓	✓	✓										2KJ3106 - ■ ■ A 0 ■ - 0 ■ Q1	
21.61	67	600	7 960	8	1.01	605/28	✓	✓	✓	✓	✓	✓	✓										2KJ3106 - ■ ■ A 0 ■ - 0 ■ P1	
20.34	71	600	7 550	8	1.16	2420/119	✓	✓	✓	✓	✓	✓	✓										2KJ3106 - ■ ■ A 0 ■ - 0 ■ N1	
19.21	75	600	7 180	8	1.32	1210/63	✓	✓	✓	✓	✓	✓	✓										2KJ3106 - ■ ■ A 0 ■ - 0 ■ M1	
16.34	89	600	9 880	8	1.64	572/35	✓	✓	✓	✓	✓	✓	✓										2KJ3106 - ■ ■ A 0 ■ - 0 ■ L1	
14.00	104	600	9 290	9	2.00	14/1			✓	✓	✓	✓	✓										2KJ3106 - ■ ■ A 0 ■ - 0 ■ K1	
12.31	118	600	8 810	9	2.50	517/42			✓	✓	✓	✓	✓										2KJ3106 - ■ ■ A 0 ■ - 0 ■ J1	
10.39	140	600	8 220	9	3.20	1672/161			✓	✓	✓	✓	✓										2KJ3106 - ■ ■ A 0 ■ - 0 ■ H1	
9.05	160	591	7 930	10	4.30	1584/175			✓	✓	✓	✓	✓										2KJ3106 - ■ ■ A 0 ■ - 0 ■ G1	
8.50	171	446	8 020	12	1.67	1760/207	✓	✓	✓	✓	✓	✓	✓										2KJ3106 - ■ ■ A 0 ■ - 0 ■ F1	
7.23	201	447	7 550	13	2.10	832/115	✓	✓	✓	✓	✓	✓	✓										2KJ3106 - ■ ■ A 0 ■ - 0 ■ E1	
6.20	234	445	7 300	13	2.70	1568/253			✓	✓	✓	✓	✓										2KJ3106 - ■ ■ A 0 ■ - 0 ■ D1	
5.45	266	429	7 100	13	3.40	376/69			✓	✓	✓	✓	✓										2KJ3106 - ■ ■ A 0 ■ - 0 ■ C1	
4.60	315	446	6 820	14	4.40	2432/529			✓	✓	✓	✓	✓										2KJ3106 - ■ ■ A 0 ■ - 0 ■ B1	
4.01	362	445	5 420	15	5.80	2304/575			✓	✓	✓	✓	✓										2KJ3106 - ■ ■ A 0 ■ - 0 ■ A1	

1) Only in conjunction with reduced-backlash version

Article No. supplement		1 or 9																					
Shaft design	→ Page 9/39																						
Adapter size		K4	B	C	D	E	F	G	H	J	K	L	M	N									4
		K2			D	E	F	G	H	J	K	L	M	N	P	Q							2
		KQ	A	B	C			D	E														7
		K8						A	B		C		D		E	F							8
Adapter type		K5	A		B	C		D	E		F	G	H										5
Gearbox mounting type	→ Page 9/34	K3	A		B	C		D	E		F	G	H										3

Selection and ordering data

Gearbox							Adapter												Article No.					
<i>i</i>	<i>n</i> ₂	<i>T</i> _{2N}	<i>F</i> _{R2}	ϕ ¹⁾	<i>J</i> _G	<i>R</i> _{ex}	K4	63	71	80	90	100	112	132	160	180	200	225	250					(Article No. supplement → below)
-	rpm	Nm	N	'	10 ⁻⁴	-	K2			80	90	100	112	132	160	180	200	225	250	280	315			
							KQ		703	704	706		708	710										
							K8						808	810		813		816			818	822		
							K5	56			140	180		210	250		280	320	360					
							K3	56			140	180		210	250		280	320	360					

D.79

330.23	4.4	840	13 400	8	0.17	369861/1120	✓	✓	✓															2KJ3207 - ■ ■ A 0 ■ - 0 ■ S1	
300.21	4.8	840	13 400	8	0.20	369861/1232	✓	✓	✓																2KJ3207 - ■ ■ A 0 ■ - 0 ■ R1
255.33	5.7	840	13 400	8	0.25	57195/224	✓	✓	✓																2KJ3207 - ■ ■ A 0 ■ - 0 ■ Q1
232.12	6.2	840	13 400	8	0.30	285975/1232	✓	✓	✓																2KJ3207 - ■ ■ A 0 ■ - 0 ■ P1
207.10	7.0	840	13 400	8	0.35	92783/448	✓	✓	✓	✓	✓														2KJ3207 - ■ ■ A 0 ■ - 0 ■ N1
185.70	7.8	840	13 400	8	0.42	57195/308	✓	✓	✓	✓	✓														2KJ3207 - ■ ■ A 0 ■ - 0 ■ M1
167.39	8.7	840	13 400	8	0.49	74989/448	✓	✓	✓	✓	✓														2KJ3207 - ■ ■ A 0 ■ - 0 ■ L1
154.51	9.4	840	13 400	8	0.58	224967/1456	✓	✓	✓	✓	✓														2KJ3207 - ■ ■ A 0 ■ - 0 ■ K1
141.04	10	840	13 400	8	0.69	110577/784	✓	✓	✓	✓	✓	✓	✓	✓											2KJ3207 - ■ ■ A 0 ■ - 0 ■ J1
117.03	12	840	13 400	8	0.87	209715/1792	✓	✓	✓	✓	✓	✓	✓	✓											2KJ3207 - ■ ■ A 0 ■ - 0 ■ H1
110.14	13	840	13 400	8	1.00	209715/1904	✓	✓	✓	✓	✓	✓	✓	✓											2KJ3207 - ■ ■ A 0 ■ - 0 ■ G1
104.03	14	840	13 400	8	1.14	69905/672	✓	✓	✓	✓	✓	✓	✓	✓											2KJ3207 - ■ ■ A 0 ■ - 0 ■ F1
88.52	16	840	13 400	8	1.39	49569/560	✓	✓	✓	✓	✓	✓	✓	✓											2KJ3207 - ■ ■ A 0 ■ - 0 ■ E1
75.83	19	840	13 400	8	1.69	26691/352			✓	✓	✓	✓	✓	✓											2KJ3207 - ■ ■ A 0 ■ - 0 ■ D1
66.67	22	840	13 400	8	2.10	59737/896			✓	✓	✓	✓	✓	✓											2KJ3207 - ■ ■ A 0 ■ - 0 ■ C1
56.25	26	840	13 400	8	2.60	72447/1288			✓	✓	✓	✓	✓	✓											2KJ3207 - ■ ■ A 0 ■ - 0 ■ B1
49.02	30	840	12 600	8	3.50	34317/700			✓	✓	✓	✓	✓	✓											2KJ3207 - ■ ■ A 0 ■ - 0 ■ A1

1) Only in conjunction with reduced-backlash version

Article No. supplement

Shaft design	→ Page 9/39	1 or 9																						
Adapter size		K4	B	C	D	E	F	G	H	J	K	L	M	N										4
		K2			D	E	F	G	H	J	K	L	M	N	P	Q								2
		KQ	A	B	C		D	E															7	
		K8					A	B		C		D		E	F								8	
		K5	A		B	C		D	E		F	G	H										5	
		K3	A		B	C		D	E		F	G	H										3	
Adapter type																								
Gearbox mounting type	→ Page 9/34	A, B, F or H																						

SIMOGEAR Gearboxes

Helical gearboxes

Transmission ratios and torques

Selection and ordering data

Gearbox							Adapter											Article No.						
<i>i</i>	<i>n</i> ₂	<i>T</i> _{2N}	<i>F</i> _{R2}	ϕ ¹⁾	<i>J</i> _G	<i>R</i> _{ex}	K4	63	71	80	90	100	112	132	160	180	200	225	250				(Article No. supplement → below)	
-	rpm	Nm	N	'	10 ⁻⁴	-	K2			80	90	100	112	132	160	180	200	225	250	280	315			
							KQ	703	704	706		708	710											
							K8					808	810		813		816			818	822			
							K5	56		140	180		210	250		280	320	360						
							K3	56		140	180		210	250		280	320	360						
Z.79																								
54.47	27	840	13 400	8	0.43	3813/70		✓	✓	✓													2KJ3107 - ■ ■ A 0 ■ - 0 ■ A2	
49.52	29	840	12 700	8	0.53	3813/77		✓	✓	✓													2KJ3107 - ■ ■ A 0 ■ - 0 ■ X1	
44.42	33	840	11 800	8	0.73	533/12		✓	✓	✓	✓	✓											2KJ3107 - ■ ■ A 0 ■ - 0 ■ W1	
39.94	36	840	10 900	8	0.83	3075/77		✓	✓	✓	✓	✓											2KJ3107 - ■ ■ A 0 ■ - 0 ■ V1	
36.12	40	840	10 200	8	0.92	1517/42		✓	✓	✓	✓	✓											2KJ3107 - ■ ■ A 0 ■ - 0 ■ U1	
33.34	43	840	13 400	8	1.08	3034/91		✓	✓	✓	✓	✓											2KJ3107 - ■ ■ A 0 ■ - 0 ■ T1	
30.54	47	840	13 400	8	1.41	2993/98		✓	✓	✓	✓	✓	✓	✓									2KJ3107 - ■ ■ A 0 ■ - 0 ■ S1	
25.62	57	840	13 400	8	1.52	205/8		✓	✓	✓	✓	✓	✓	✓	✓								2KJ3107 - ■ ■ A 0 ■ - 0 ■ R1	
24.12	60	840	13 100	8	1.73	410/17		✓	✓	✓	✓	✓	✓	✓	✓								2KJ3107 - ■ ■ A 0 ■ - 0 ■ Q1	
22.13	66	840	12 600	8	1.90	1394/63		✓	✓	✓	✓	✓	✓	✓	✓								2KJ3107 - ■ ■ A 0 ■ - 0 ■ P1	
19.33	75	840	11 900	8	2.70	1353/70		✓	✓	✓	✓	✓	✓	✓	✓								2KJ3107 - ■ ■ A 0 ■ - 0 ■ N1	
17.31	84	840	11 400	8	3.30	2665/154			✓	✓	✓	✓	✓	✓	✓								2KJ3107 - ■ ■ A 0 ■ - 0 ■ M1	
15.13	96	840	10 800	8	3.90	1271/84			✓	✓	✓	✓	✓	✓	✓								2KJ3107 - ■ ■ A 0 ■ - 0 ■ L1	
12.99	112	840	10 100	8	4.30	2091/161			✓	✓	✓	✓	✓	✓	✓								2KJ3107 - ■ ■ A 0 ■ - 0 ■ K1	
11.48	126	840	9 670	8	5.50	287/25			✓	✓	✓	✓	✓	✓	✓								2KJ3107 - ■ ■ A 0 ■ - 0 ■ J1	
9.76	149	815	9 100	9	7.00	205/21					✓	✓	✓	✓									2KJ3107 - ■ ■ A 0 ■ - 0 ■ H1	
8.37	173	790	8 600	9	9.30	410/49					✓	✓	✓	✓									2KJ3107 - ■ ■ A 0 ■ - 0 ■ G1	
8.19	177	715	8 490	11	4.00	3965/484			✓	✓	✓	✓	✓	✓									2KJ3107 - ■ ■ A 0 ■ - 0 ■ F1	
7.16	203	730	8 030	12	4.80	1891/264			✓	✓	✓	✓	✓	✓									2KJ3107 - ■ ■ A 0 ■ - 0 ■ E1	
6.15	236	715	7 860	12	5.40	3111/506			✓	✓	✓	✓	✓	✓									2KJ3107 - ■ ■ A 0 ■ - 0 ■ D1	
5.43	267	685	7 700	13	6.90	2989/550			✓	✓	✓	✓	✓	✓									2KJ3107 - ■ ■ A 0 ■ - 0 ■ C1	
4.62	314	775	7 470	13	9.10	305/66					✓	✓	✓	✓									2KJ3107 - ■ ■ A 0 ■ - 0 ■ B1	
3.96	366	775	3 710	14	12.00	305/77					✓	✓	✓	✓									2KJ3107 - ■ ■ A 0 ■ - 0 ■ A1	

1) Only in conjunction with reduced-backlash version

Article No. supplement		1 or 9																					
Shaft design	→ Page 9/39																						
Adapter size		K4	B	C	D	E	F	G	H	J	K	L	M	N									4
		K2			D	E	F	G	H	J	K	L	M	N	P	Q							2
		KQ		A	B	C		D	E														7
		K8						A	B		C		D		E	F							8
Adapter type		K5		A	B	C		D	E		F	G	H										5
Gearbox mounting type	→ Page 9/34	K3		A		B	C		D	E		F	G	H									3

Selection and ordering data

Gearbox							Adapter											Article No.						
<i>i</i>	<i>n</i> ₂	<i>T</i> _{2N}	<i>F</i> _{R2}	ϕ ¹⁾	<i>J</i> _G	<i>R</i> _{ex}	K4	63	71	80	90	100	112	132	160	180	200	225	250				(Article No. supplement → below)	
-	rpm	Nm	N	'	10 ⁻⁴	-	K2			80	90	100	112	132	160	180	200	225	250	280	315			
							KQ		703	704	706		708	710										
							K8						808	810		813		816			818	822		
							K5		56		140	180		210	250		280	320	360					
							K3		56		140	180		210	250		280	320	360					
D.89																								
311.60	4.7	1 680	18 500	7	0.41	132432/425				✓	✓													2KJ3208 - ■ ■ A 0 ■ - 0 ■ S1
283.28	5.1	1 680	18 500	7	0.50	264864/935				✓	✓													2KJ3208 - ■ ■ A 0 ■ - 0 ■ R1
254.09	5.7	1 680	18 500	7	0.70	64792/255				✓	✓	✓	✓											2KJ3208 - ■ ■ A 0 ■ - 0 ■ Q1
228.45	6.3	1 680	18 500	7	0.79	42720/187				✓	✓	✓	✓											2KJ3208 - ■ ■ A 0 ■ - 0 ■ P1
206.62	7.0	1 680	18 500	7	0.87	52688/255				✓	✓	✓	✓											2KJ3208 - ■ ■ A 0 ■ - 0 ■ N1
190.73	7.6	1 680	18 500	7	1.03	210752/1105				✓	✓	✓	✓											2KJ3208 - ■ ■ A 0 ■ - 0 ■ M1
174.71	8.3	1 680	18 500	7	1.35	103952/595				✓	✓	✓	✓	✓	✓									2KJ3208 - ■ ■ A 0 ■ - 0 ■ L1
146.59	9.9	1 680	18 500	7	1.43	2492/17				✓	✓	✓	✓	✓	✓									2KJ3208 - ■ ■ A 0 ■ - 0 ■ K1
137.97	11	1 680	18 500	7	1.63	39872/289				✓	✓	✓	✓	✓	✓									2KJ3208 - ■ ■ A 0 ■ - 0 ■ J1
126.58	11	1 680	18 500	7	1.78	5696/45				✓	✓	✓	✓	✓	✓									2KJ3208 - ■ ■ A 0 ■ - 0 ■ H1
110.57	13	1 680	18 500	7	2.50	46992/425				✓	✓	✓	✓	✓	✓									2KJ3208 - ■ ■ A 0 ■ - 0 ■ G1
98.99	15	1 680	18 500	7	3.10	18512/187				✓	✓	✓	✓	✓	✓									2KJ3208 - ■ ■ A 0 ■ - 0 ■ F1
86.56	17	1 680	18 500	7	3.70	22072/255				✓	✓	✓	✓	✓	✓									2KJ3208 - ■ ■ A 0 ■ - 0 ■ E1
74.30	20	1 680	18 500	7	4.00	8544/115				✓	✓	✓	✓	✓	✓									2KJ3208 - ■ ■ A 0 ■ - 0 ■ D1
65.67	22	1 680	18 500	7	5.00	139552/2125				✓	✓	✓	✓	✓	✓	✓								2KJ3208 - ■ ■ A 0 ■ - 0 ■ C1
55.84	26	1 680	18 500	7	6.40	2848/51						✓	✓	✓	✓	✓								2KJ3208 - ■ ■ A 0 ■ - 0 ■ B1
47.87	30	1 680	18 500	7	8.50	5696/119						✓	✓	✓	✓	✓								2KJ3208 - ■ ■ A 0 ■ - 0 ■ A1

1) Only in conjunction with reduced-backlash version

Article No. supplement		1 or 9																						
Shaft design	→ Page 9/39																							
Adapter size		K4	B	C	D	E	F	G	H	J	K	L	M	N									4	
		K2			D	E	F	G	H	J	K	L	M	N	P	Q								2
		KQ		A	B	C		D	E														7	
		K8						A	B	C		D		E	F								8	
		K5		A		B	C		D	E		F	G	H									5	
		K3		A		B	C		D	E		F	G	H									3	
Adapter type																								
Gearbox mounting type	→ Page 9/34	A, B, F or H																						

SIMOGEAR Gearboxes

Helical gearboxes

Transmission ratios and torques

Selection and ordering data

Gearbox							Adapter												Article No.								
i	n_2	T_{2N}	F_{R2}	$\phi^{1)}$	J_G	R_{ex}	K4	63	71	80	90	100	112	132	160	180	200	225	250					(Article No. supplement → below)			
-	rpm	Nm	N	'	10^{-4}	-	K2			80	90	100	112	132	160	180	200	225	250	280	315						
							KQ		703	704	706		708	710													
							K8						808	810		813		816			818	822					
							K5	56		140	180		210	250			280	320	360								
							K3	56		140	180		210	250			280	320	360								
Z.89																											
57.36	25	1 680	18 500	6	1.34	2581/45				✓	✓	✓	✓													2KJ3108 - ■ ■ A 0 ■ - 0 ■ A2	
51.78	28	1 680	18 500	6	1.46	2848/55				✓	✓	✓	✓													2KJ3108 - ■ ■ A 0 ■ - 0 ■ X1	
46.97	31	1 680	18 500	6	1.71	1691/36				✓	✓	✓	✓													2KJ3108 - ■ ■ A 0 ■ - 0 ■ W1	
43.36	33	1 680	18 500	6	2.0	1691/39				✓	✓	✓	✓													2KJ3108 - ■ ■ A 0 ■ - 0 ■ V1	
39.41	37	1 680	18 500	6	2.3	2759/70				✓	✓	✓	✓	✓	✓											2KJ3108 - ■ ■ A 0 ■ - 0 ■ U1	
33.38	43	1 680	18 500	6	2.8	267/8				✓	✓	✓	✓	✓	✓											2KJ3108 - ■ ■ A 0 ■ - 0 ■ T1	
31.41	46	1 680	18 500	6	2.8	534/17				✓	✓	✓	✓	✓	✓											2KJ3108 - ■ ■ A 0 ■ - 0 ■ S1	
29.01	50	1 680	18 500	6	4.3	3916/135				✓	✓	✓	✓	✓	✓											2KJ3108 - ■ ■ A 0 ■ - 0 ■ R1	
25.81	56	1 680	18 500	6	5.3	2581/100				✓	✓	✓	✓	✓	✓											2KJ3108 - ■ ■ A 0 ■ - 0 ■ Q1	
22.92	63	1 680	17 500	6	6.4	1513/66				✓	✓	✓	✓	✓	✓											2KJ3108 - ■ ■ A 0 ■ - 0 ■ P1	
20.52	71	1 680	16 100	6	6.4	7387/360				✓	✓	✓	✓	✓	✓											2KJ3108 - ■ ■ A 0 ■ - 0 ■ N1	
17.54	83	1 680	14 200	7	7.5	6052/345				✓	✓	✓	✓	✓	✓											2KJ3108 - ■ ■ A 0 ■ - 0 ■ M1	
15.66	93	1 680	12 900	7	9.5	1958/125				✓	✓	✓	✓	✓	✓	✓										2KJ3108 - ■ ■ A 0 ■ - 0 ■ L1	
13.84	105	1 680	11 600	7	11	623/45						✓	✓	✓	✓	✓										2KJ3108 - ■ ■ A 0 ■ - 0 ■ K1	
12.15	119	1 630	10 800	7	15	3827/315						✓	✓	✓	✓	✓										2KJ3108 - ■ ■ A 0 ■ - 0 ■ J1	
10.58	137	1 590	10 600	7	19	3649/345						✓	✓	✓	✓	✓										2KJ3108 - ■ ■ A 0 ■ - 0 ■ H1	
9.04	160	1 560	11 900	7	24	2848/315						✓	✓	✓	✓	✓										2KJ3108 - ■ ■ A 0 ■ - 0 ■ G1	
7.74	187	1 530	12 700	7	30	178/23						✓	✓	✓	✓	✓										2KJ3108 - ■ ■ A 0 ■ - 0 ■ F1	
6.89	210	1 050	10 100	11	12	62/9						✓	✓	✓	✓	✓										2KJ3108 - ■ ■ A 0 ■ - 0 ■ E1	
6.05	240	1 060	10 900	11	17	2666/441						✓	✓	✓	✓	✓										2KJ3108 - ■ ■ A 0 ■ - 0 ■ D1	
5.26	276	1 060	11 600	11	21	2542/483						✓	✓	✓	✓	✓										2KJ3108 - ■ ■ A 0 ■ - 0 ■ C1	
4.50	322	1 060	11 500	12	28	1984/441						✓	✓	✓	✓	✓										2KJ3108 - ■ ■ A 0 ■ - 0 ■ B1	
3.85	377	1 060	11 100	12	35	620/161						✓	✓	✓	✓	✓										2KJ3108 - ■ ■ A 0 ■ - 0 ■ A1	

1) Only in conjunction with reduced-backlash version

Article No. supplement		1 or 9																				
Shaft design	→ Page 9/39																					
Adapter size		K4	B	C	D	E	F	G	H	J	K	L	M	N					4			
		K2			D	E	F	G	H	J	K	L	M	N	P	Q					2	
		KQ	A	B	C					D	E									7		
		K8									A	B	C					D	E	F	8	
		K5	A	B	C					D	E	F	G	H								
	K3	A	B	C					D	E	F	G	H									3
Adapter type																						
Gearbox mounting type	→ Page 9/34	A, B, F or H																				

Selection and ordering data

Gearbox							Adapter											Article No.					
<i>i</i>	<i>n</i> ₂	<i>T</i> _{2N}	<i>F</i> _{R2}	ϕ ¹⁾	<i>J</i> _G	<i>R</i> _{ex}	K4	63	71	80	90	100	112	132	160	180	200	225	250			(Article No. supplement → below)	
-	rpm	Nm	N	'	10 ⁻⁴	-	K2			80	90	100	112	132	160	180	200	225	250	280	315		
							KQ	703	704	706		708	710										
							K8					808	810		813		816			818	822		
							K5	56		140	180		210	250		280	320	360					
							K3	56		140	180		210	250		280	320	360					
D.109																							
348.88	4.2	3 100	20 200	-	1.27	263755/756				✓	✓	✓										2KJ3210 - ■ ■ A 0 ■ - 0 ■ T1	
314.98	4.6	3 100	20 200	-	1.36	72760/231				✓	✓	✓										2KJ3210 - ■ ■ A 0 ■ - 0 ■ S1	
285.72	5.1	3 100	20 200	-	1.60	864025/3024				✓	✓	✓										2KJ3210 - ■ ■ A 0 ■ - 0 ■ R1	
263.74	5.5	3 100	20 200	-	1.88	864025/3276				✓	✓	✓										2KJ3210 - ■ ■ A 0 ■ - 0 ■ Q1	
239.75	6.0	3 100	20 200	-	2.1	281945/1176				✓	✓	✓	✓	✓								2KJ3210 - ■ ■ A 0 ■ - 0 ■ P1	
203.01	7.1	3 100	20 200	-	2.6	45475/224				✓	✓	✓	✓	✓								2KJ3210 - ■ ■ A 0 ■ - 0 ■ N1	
191.07	7.6	3 100	20 200	-	2.6	2675/14				✓	✓	✓	✓	✓								2KJ3210 - ■ ■ A 0 ■ - 0 ■ M1	
176.45	8.2	3 100	20 200	-	4.0	100045/567				✓	✓	✓	✓	✓								2KJ3210 - ■ ■ A 0 ■ - 0 ■ L1	
157.00	9.2	3 100	20 200	-	5.0	52751/336				✓	✓	✓	✓	✓								2KJ3210 - ■ ■ A 0 ■ - 0 ■ K1	
139.44	10	3 100	20 200	-	5.9	773075/5544				✓	✓	✓	✓	✓								2KJ3210 - ■ ■ A 0 ■ - 0 ■ J1	
124.82	12	3 100	20 200	-	5.8	754885/6048				✓	✓	✓	✓	✓								2KJ3210 - ■ ■ A 0 ■ - 0 ■ H1	
106.70	14	3 100	20 200	-	6.7	154615/1449				✓	✓	✓	✓	✓								2KJ3210 - ■ ■ A 0 ■ - 0 ■ G1	
95.28	15	3 100	20 200	-	8.5	20009/210				✓	✓	✓	✓	✓								2KJ3210 - ■ ■ A 0 ■ - 0 ■ F1	
84.21	17	3 100	20 200	-	9.6	9095/108					✓	✓	✓	✓								2KJ3210 - ■ ■ A 0 ■ - 0 ■ E1	
73.90	20	3 100	20 200	-	13	391085/5292					✓	✓	✓	✓								2KJ3210 - ■ ■ A 0 ■ - 0 ■ D1	
64.34	23	3 100	20 200	-	16	372895/5796					✓	✓	✓	✓								2KJ3210 - ■ ■ A 0 ■ - 0 ■ C1	
55.00	26	3 090	20 200	-	20	72760/1323					✓	✓	✓	✓								2KJ3210 - ■ ■ A 0 ■ - 0 ■ B1	
47.08	31	2 930	20 200	-	25	45475/966					✓	✓	✓	✓								2KJ3210 - ■ ■ A 0 ■ - 0 ■ A1	

1) Only in conjunction with reduced-backlash version

Article No. supplement		1 or 9																					
Shaft design	→ Page 9/39																						
Adapter size		K4	B	C	D	E	F	G	H	J	K	L	M	N								4	
		K2			D	E	F	G	H	J	K	L	M	N	P	Q							2
		KQ	A	B	C		D	E														7	
		K8					A	B		C		D		E	F							8	
		K5	A		B	C		D	E		F	G	H									5	
		K3	A		B	C		D	E		F	G	H									3	
Adapter type																							
Gearbox mounting type	→ Page 9/34	A, B, F or H																					



SIMOGEAR Gearboxes

Helical gearboxes

Transmission ratios and torques

Selection and ordering data

Gearbox							Adapter											Article No.				
i	n_2	T_{2N}	F_{R2}	$\phi^{1)}$	J_G	R_{ex}	K4	63	71	80	90	100	112	132	160	180	200	225	250			(Article No. supplement → below)
-	rpm	Nm	N	'	10^{-4}	-	K2			80	90	100	112	132	160	180	200	225	250	280	315	
					kgm^2		KQ	703	704	706		708	710									
							K8					808	810		813		816			818	822	
							K5	56		140	180		210	250		280	320	360				
							K3	56		140	180		210	250		280	320	360				
Z.109																						
51.17	28	3 100	20 200	-	4.7	5015/98					✓	✓	✓	✓	✓							2KJ3110 - ■ ■ A 0 ■ - 0 ■ X1
43.64	33	3 100	20 200	-	6.0	9775/224					✓	✓	✓	✓	✓							2KJ3110 - ■ ■ A 0 ■ - 0 ■ W1
41.07	35	3 100	20 200	-	6.8	575/14					✓	✓	✓	✓	✓							2KJ3110 - ■ ■ A 0 ■ - 0 ■ V1
38.12	38	3 100	20 200	-	7.4	9605/252					✓	✓	✓	✓	✓							2KJ3110 - ■ ■ A 0 ■ - 0 ■ U1
33.70	43	3 100	20 200	-	9	1887/56					✓	✓	✓	✓	✓							2KJ3110 - ■ ■ A 0 ■ - 0 ■ T1
30.08	48	3 100	20 000	-	11	9265/308					✓	✓	✓	✓	✓							2KJ3110 - ■ ■ A 0 ■ - 0 ■ S1
27.07	54	3 040	19 300	-	13	9095/336					✓	✓	✓	✓	✓							2KJ3110 - ■ ■ A 0 ■ - 0 ■ R1
23.49	62	2 920	18 500	-	15	7565/322					✓	✓	✓	✓	✓							2KJ3110 - ■ ■ A 0 ■ - 0 ■ Q1
21.13	69	2 830	17 900	-	18	1479/70					✓	✓	✓	✓	✓	✓						2KJ3110 - ■ ■ A 0 ■ - 0 ■ P1
18.47	79	2 720	17 200	-	21	6205/336						✓	✓	✓	✓	✓	✓					2KJ3110 - ■ ■ A 0 ■ - 0 ■ N1
16.48	88	2 630	16 600	-	25	1615/98						✓	✓	✓	✓	✓	✓	✓				2KJ3110 - ■ ■ A 0 ■ - 0 ■ M1
14.52	100	2 570	15 900	-	30	4675/322						✓	✓	✓	✓	✓	✓	✓				2KJ3110 - ■ ■ A 0 ■ - 0 ■ L1
12.72	114	2 510	15 200	-	37	1870/147						✓	✓	✓	✓	✓	✓	✓				2KJ3110 - ■ ■ A 0 ■ - 0 ■ K1
11.09	131	2 460	14 500	-	44	255/23						✓	✓	✓	✓	✓	✓	✓				2KJ3110 - ■ ■ A 0 ■ - 0 ■ J1
10.12	143	2 430	14 000	-	51	425/42						✓	✓	✓	✓	✓	✓	✓				2KJ3110 - ■ ■ A 0 ■ - 0 ■ H1
8.71	166	2 380	13 200	-	64	2805/322							✓	✓	✓	✓	✓	✓				2KJ3110 - ■ ■ A 0 ■ - 0 ■ G1
8.41	172	2 290	12 800	-	29	589/70					✓	✓	✓	✓	✓	✓	✓	✓				2KJ3110 - ■ ■ A 0 ■ - 0 ■ F1
7.41	196	2 280	12 300	-	34	341/46					✓	✓	✓	✓	✓	✓	✓	✓				2KJ3110 - ■ ■ A 0 ■ - 0 ■ E1
6.50	223	2 280	12 300	-	42	682/105					✓	✓	✓	✓	✓	✓	✓	✓				2KJ3110 - ■ ■ A 0 ■ - 0 ■ D1
5.66	256	2 290	12 300	-	51	651/115					✓	✓	✓	✓	✓	✓	✓	✓				2KJ3110 - ■ ■ A 0 ■ - 0 ■ C1
5.17	280	2 280	12 200	-	60	31/6					✓	✓	✓	✓	✓	✓	✓	✓				2KJ3110 - ■ ■ A 0 ■ - 0 ■ B1
4.45	326	2 150	12 000	-	75	1023/230							✓	✓	✓	✓	✓	✓				2KJ3110 - ■ ■ A 0 ■ - 0 ■ A1

1) Only in conjunction with reduced-backlash version

Article No. supplement		1 or 9																					
Shaft design	→ Page 9/39																						
Adapter size		K4	B	C	D	E	F	G	H	J	K	L	M	N								4	
		K2			D	E	F	G	H	J	K	L	M	N	P	Q							2
		KQ	A	B	C		D	E															7
		K8					A	B		C		D		E	F								8
		K5	A	B	C		D	E		F	G	H											5
	K3	A	B	C		D	E		F	G	H											3	
Adapter type																							
Gearbox mounting type	→ Page 9/34	A, B, F or H																					

Selection and ordering data

Gearbox							Adapter										Article No.						
i	n ₂	T _{2N}	F _{R2}	φ ¹⁾	J _G	R _{ex}	K4	63	71	80	90	100	112	132	160	180	200	225	250			(Article No. supplement → below)	
-	rpm	Nm	N	'	10 ⁻⁴	-	K2			80	90	100	112	132	160	180	200	225	250	280	315		
							KQ	703	704	706		708	710										
							K8					808	810		813		816			818	822		
							K5	56		140	180		210	250		280	320	360					
							K3	56		140	180		210	250		280	320	360					
D.129																							
373.00	3.9	5 000	27 000	-	3.3	523481/1404					✓	✓	✓									2KJ3211 - ■ A 0 ■ - 0 ■ S1	
344.17	4.2	5 000	27 000	-	3.9	523481/1521					✓	✓	✓									2KJ3211 - ■ A 0 ■ - 0 ■ R1	
316.90	4.6	5 000	27 000	-	4.5	259541/819					✓	✓	✓	✓	✓							2KJ3211 - ■ A 0 ■ - 0 ■ Q1	
270.24	5.4	5 000	27 000	-	5.6	505885/1872					✓	✓	✓	✓	✓							2KJ3211 - ■ A 0 ■ - 0 ■ P1	
254.34	5.7	5 000	27 000	-	6.4	505885/1989					✓	✓	✓	✓	✓							2KJ3211 - ■ A 0 ■ - 0 ■ N1	
236.03	6.1	5 000	27 000	-	6.9	497087/2106					✓	✓	✓	✓	✓							2KJ3211 - ■ A 0 ■ - 0 ■ M1	
208.67	6.9	5 000	27 000	-	8.4	162763/780					✓	✓	✓	✓	✓							2KJ3211 - ■ A 0 ■ - 0 ■ L1	
186.28	7.8	5 000	27 000	-	9.9	479491/2574					✓	✓	✓	✓	✓							2KJ3211 - ■ A 0 ■ - 0 ■ K1	
167.63	8.7	5 000	27 000	-	12	470693/2808					✓	✓	✓	✓	✓							2KJ3211 - ■ A 0 ■ - 0 ■ J1	
145.49	10	5 000	27 000	-	14	391511/2691					✓	✓	✓	✓	✓							2KJ3211 - ■ A 0 ■ - 0 ■ H1	
130.84	11	5 000	27 000	-	16	127571/975					✓	✓	✓	✓	✓							2KJ3211 - ■ A 0 ■ - 0 ■ G1	
114.36	13	5 000	27 000	-	19	321127/2808						✓	✓	✓	✓							2KJ3211 - ■ A 0 ■ - 0 ■ F1	
102.05	14	5 000	27 000	-	23	83581/819						✓	✓	✓	✓							2KJ3211 - ■ A 0 ■ - 0 ■ E1	
89.91	16	5 000	27 000	-	27	241945/2691						✓	✓	✓	✓							2KJ3211 - ■ A 0 ■ - 0 ■ D1	
78.78	18	5 000	27 000	-	31	193556/2457						✓	✓	✓	✓							2KJ3211 - ■ A 0 ■ - 0 ■ C1	
68.66	21	5 000	27 000	-	37	61586/897						✓	✓	✓	✓							2KJ3211 - ■ A 0 ■ - 0 ■ B1	
62.66	23	5 000	27 000	-	44	21995/351						✓	✓	✓	✓							2KJ3211 - ■ A 0 ■ - 0 ■ A1	

1) Only in conjunction with reduced-backlash version

Article No. supplement		1 or 9																				
Shaft design	→ Page 9/39																					
Adapter size		K4	B	C	D	E	F	G	H	J	K	L	M	N							4	
		K2			D	E	F	G	H	J	K	L	M	N	P	Q						2
		KQ		A	B	C		D	E													7
		K8						A	B		C		D		E	F						8
		K5		A		B	C		D	E		F	G	H								5
	K3		A		B	C		D	E		F	G	H									3
Adapter type																						
Gearbox mounting type	→ Page 9/34	A, B, F or H																				

SIMOGEAR Gearboxes

Helical gearboxes

Transmission ratios and torques

Selection and ordering data

Gearbox							Adapter											Article No.					
<i>i</i>	<i>n</i> ₂	<i>T</i> _{2N}	<i>F</i> _{R2}	ϕ ¹⁾	<i>J</i> _G	<i>R</i> _{ex}	K4	63	71	80	90	100	112	132	160	180	200	225	250				(Article No. supplement → below)
-	rpm	Nm	N	'	10 ⁻⁴	-	K2			80	90	100	112	132	160	180	200	225	250	280	315		
					kgm ²		KQ	703	704	706		708	710										
							K8					808	810		813		816			818	822		
							K5	56		140	180		210	250		280	320	360					
							K3	56		140	180		210	250		280	320	360					

Z.129																						
62.48	23	5 000	27 000	-	7.5	11371/182					✓	✓	✓	✓	✓							2KJ3111 - ■ ■ A 0 ■ - 0 ■ X1
53.47	27	5 000	27 000	-	9.5	5561/104					✓	✓	✓	✓	✓							2KJ3111 - ■ ■ A 0 ■ - 0 ■ W1
50.33	29	5 000	27 000	-	11	11122/221					✓	✓	✓	✓	✓							2KJ3111 - ■ ■ A 0 ■ - 0 ■ V1
47.18	31	5 000	27 000	-	12	11039/234					✓	✓	✓	✓	✓							2KJ3111 - ■ ■ A 0 ■ - 0 ■ U1
41.82	35	5 000	27 000	-	14	10873/260					✓	✓	✓	✓	✓							2KJ3111 - ■ ■ A 0 ■ - 0 ■ T1
37.15	39	5 000	26 000	-	17	5312/143					✓	✓	✓	✓	✓							2KJ3111 - ■ ■ A 0 ■ - 0 ■ S1
33.52	43	5 000	25 000	-	20	1743/52					✓	✓	✓	✓	✓							2KJ3111 - ■ ■ A 0 ■ - 0 ■ R1
29.70	49	5 000	23 800	-	25	8881/299					✓	✓	✓	✓	✓							2KJ3111 - ■ ■ A 0 ■ - 0 ■ Q1
26.30	55	5 000	22 600	-	28	8549/325					✓	✓	✓	✓	✓	✓						2KJ3111 - ■ ■ A 0 ■ - 0 ■ P1
23.41	62	5 000	21 600	-	33	913/39						✓	✓	✓	✓	✓	✓					2KJ3111 - ■ ■ A 0 ■ - 0 ■ N1
20.98	69	5 000	20 600	-	40	1909/91						✓	✓	✓	✓	✓	✓	✓				2KJ3111 - ■ ■ A 0 ■ - 0 ■ M1
18.60	78	5 000	19 500	-	47	5561/299						✓	✓	✓	✓	✓	✓	✓				2KJ3111 - ■ ■ A 0 ■ - 0 ■ L1
16.42	88	5 000	18 200	-	57	1494/91						✓	✓	✓	✓	✓	✓	✓	✓			2KJ3111 - ■ ■ A 0 ■ - 0 ■ K1
14.43	100	4 940	16 400	-	69	332/23						✓	✓	✓	✓	✓	✓	✓	✓			2KJ3111 - ■ ■ A 0 ■ - 0 ■ J1
13.07	111	4 850	16 400	-	78	3569/273						✓	✓	✓	✓	✓	✓	✓	✓			2KJ3111 - ■ ■ A 0 ■ - 0 ■ H1
11.38	127	4 760	17 200	-	95	3403/299							✓	✓	✓	✓	✓	✓	✓			2KJ3111 - ■ ■ A 0 ■ - 0 ■ G1
9.33	155	4 660	17 100	-	126	1577/169								✓	✓	✓	✓	✓	✓			2KJ3111 - ■ ■ A 0 ■ - 0 ■ F1
8.53	170	3 640	16 200	-	66	162/19						✓	✓	✓	✓	✓	✓	✓	✓			2KJ3111 - ■ ■ A 0 ■ - 0 ■ E1
7.50	193	3 630	16 100	-	80	3276/437						✓	✓	✓	✓	✓	✓	✓	✓			2KJ3111 - ■ ■ A 0 ■ - 0 ■ D1
6.79	214	3 630	15 900	-	91	129/19						✓	✓	✓	✓	✓	✓	✓	✓			2KJ3111 - ■ ■ A 0 ■ - 0 ■ C1
5.91	245	3 610	15 700	-	112	2583/437							✓	✓	✓	✓	✓	✓	✓			2KJ3111 - ■ ■ A 0 ■ - 0 ■ B1
4.85	299	3 270	15 300	-	151	63/13								✓	✓	✓	✓	✓	✓			2KJ3111 - ■ ■ A 0 ■ - 0 ■ A1

1) Only in conjunction with reduced-backlash version

Article No. supplement																						
Shaft design	→ Page 9/39											1 or 9										
Adapter size	K4	B	C	D	E	F	G	H	J	K	L	M	N									4
	K2			D	E	F	G	H	J	K	L	M	N	P	Q							2
	KQ	A	B	C			D	E														7
	K8						A	B		C		D		E	F							8
	K5	A		B	C			D	E		F	G	H									5
	K3	A		B	C		D	E		F	G	H										3
Adapter type																						
Gearbox mounting type	→ Page 9/34											A, B, F or H										

Selection and ordering data

Gearbox							Adapter											Article No.						
<i>i</i>	<i>n</i> ₂	<i>T</i> _{2N}	<i>F</i> _{R2}	ϕ ¹⁾	<i>J</i> _G	<i>R</i> _{ex}	K4	63	71	80	90	100	112	132	160	180	200	225	250				(Article No. supplement → below)	
-	rpm	Nm	N	'	10 ⁻⁴	-	K2			80	90	100	112	132	160	180	200	225	250	280	315			
							KQ	703	704	706		708	710											
							K8					808	810		813		816			818	822			
							K5	56		140	180		210	250		280	320	360						
							K3	56		140	180		210	250		280	320	360						
D.149																								
328.38	4.4	8 000	51 200	-	7.1	321813/980						✓	✓	✓	✓								2KJ3212 - ■ ■ A 0 ■ - 0 ■ W1	
281.04	5.2	8 000	51 200	-	9	157383/560						✓	✓	✓	✓								2KJ3212 - ■ ■ A 0 ■ - 0 ■ V1	
264.51	5.5	8 000	51 200	-	10	157383/595						✓	✓	✓	✓								2KJ3212 - ■ ■ A 0 ■ - 0 ■ U1	
247.95	5.8	8 000	51 200	-	11	4959/20						✓	✓	✓	✓								2KJ3212 - ■ ■ A 0 ■ - 0 ■ T1	
219.80	6.6	8 000	51 200	-	14	307719/1400						✓	✓	✓	✓								2KJ3212 - ■ ■ A 0 ■ - 0 ■ S1	
195.24	7.4	8 000	51 200	-	16	75168/385						✓	✓	✓	✓								2KJ3212 - ■ ■ A 0 ■ - 0 ■ R1	
176.18	8.2	8 000	51 200	-	19	7047/40						✓	✓	✓	✓								2KJ3212 - ■ ■ A 0 ■ - 0 ■ Q1	
156.11	9.3	8 000	51 200	-	23	251343/1610						✓	✓	✓	✓								2KJ3212 - ■ ■ A 0 ■ - 0 ■ P1	
138.26	10	8 000	51 200	-	26	241947/1750						✓	✓	✓	✓	✓							2KJ3212 - ■ ■ A 0 ■ - 0 ■ N1	
123.04	12	8 000	51 200	-	31	8613/70						✓	✓	✓	✓	✓	✓						2KJ3212 - ■ ■ A 0 ■ - 0 ■ M1	
110.26	13	8 000	51 200	-	37	54027/490						✓	✓	✓	✓	✓	✓	✓					2KJ3212 - ■ ■ A 0 ■ - 0 ■ L1	
97.75	15	8 000	51 200	-	43	157383/1610						✓	✓	✓	✓	✓	✓	✓					2KJ3212 - ■ ■ A 0 ■ - 0 ■ K1	
86.29	17	8 000	51 200	-	52	21141/245						✓	✓	✓	✓	✓	✓	✓	✓				2KJ3212 - ■ ■ A 0 ■ - 0 ■ J1	
75.87	19	8 000	51 200	-	63	61074/805						✓	✓	✓	✓	✓	✓	✓	✓				2KJ3212 - ■ ■ A 0 ■ - 0 ■ H1	
68.71	21	8 000	51 200	-	70	33669/490						✓	✓	✓	✓	✓	✓	✓	✓				2KJ3212 - ■ ■ A 0 ■ - 0 ■ G1	
59.82	24	8 000	51 200	-	85	96309/1610							✓	✓	✓	✓	✓	✓	✓				2KJ3212 - ■ ■ A 0 ■ - 0 ■ F1	
49.05	30	8 000	47 900	-	110	44631/910							✓	✓	✓	✓	✓	✓	✓				2KJ3212 - ■ ■ A 0 ■ - 0 ■ E1	
43.51	33	8 000	45 800	-	72	55042/1265						✓	✓	✓	✓	✓	✓	✓	✓				2KJ3212 - ■ ■ A 0 ■ - 0 ■ D1	
39.41	37	8 000	44 100	-	82	91031/2310						✓	✓	✓	✓	✓	✓	✓	✓				2KJ3212 - ■ ■ A 0 ■ - 0 ■ C1	
34.31	42	8 000	41 900	-	101	86797/2530							✓	✓	✓	✓	✓	✓	✓				2KJ3212 - ■ ■ A 0 ■ - 0 ■ B1	
28.13	52	8 000	38 800	-	133	40223/1430							✓	✓	✓	✓	✓	✓	✓				2KJ3212 - ■ ■ A 0 ■ - 0 ■ A1	

1) Only in conjunction with reduced-backlash version

Article No. supplement		1 or 9																					
Shaft design	→ Page 9/39																						
Adapter size		K4	B	C	D	E	F	G	H	J	K	L	M	N								4	
		K2			D	E	F	G	H	J	K	L	M	N	P	Q							2
		KQ	A	B	C		D	E															7
		K8					A	B		C		D	E	F									8
		K5	A	B	C		D	E		F	G	H											5
		K3	A	B	C		D	E		F	G	H											3
Adapter type																							
Gearbox mounting type	→ Page 9/34	A, B, F or H																					

SIMOGEAR Gearboxes

Helical gearboxes

Transmission ratios and torques

Selection and ordering data

Gearbox							Adapter													Article No.																		
i	n_2	T_{2N}	F_{R2}	$\phi^{1)}$	J_G	R_{ex}	K4	63	71	80	90	100	112	132	160	180	200	225	250																			(Article No. supplement → below)
-	rpm	Nm	N	'	10^{-4}	-	K2			80	90	100	112	132	160	180	200	225	250	280	315																	
							KQ		703	704	706		708	710																								
							K8						808	810		813		816																				
							K5	56		140	180		210	250			280	320	360																			
							K3	56		140	180		210	250			280	320	360																			

Z.149

56.64	26	8 000	50 500	-	19	4814/85							✓	✓	✓	✓																			2KJ3112 - ■ ■ A 0 ■ - 0 ■ W1
52.84	27	7 710	49 600	-	21	2378/45							✓	✓	✓	✓																			2KJ3112 - ■ ■ A 0 ■ - 0 ■ V1
46.98	31	7 570	47 700	-	25	2349/50							✓	✓	✓	✓																			2KJ3112 - ■ ■ A 0 ■ - 0 ■ U1
42.18	34	7 660	45 700	-	30	464/11							✓	✓	✓	✓																			2KJ3112 - ■ ■ A 0 ■ - 0 ■ T1
38.18	38	7 550	44 200	-	35	2291/60							✓	✓	✓	✓																			2KJ3112 - ■ ■ A 0 ■ - 0 ■ S1
33.54	43	8 000	41 500	-	43	3857/115							✓	✓	✓	✓																			2KJ3112 - ■ ■ A 0 ■ - 0 ■ R1
30.39	48	8 000	40 000	-	50	3799/125							✓	✓	✓	✓	✓																		2KJ3112 - ■ ■ A 0 ■ - 0 ■ Q1
27.07	54	8 000	38 200	-	59	406/15							✓	✓	✓	✓	✓	✓																	2KJ3112 - ■ ■ A 0 ■ - 0 ■ P1
24.30	60	8 000	36 700	-	70	2552/105							✓	✓	✓	✓	✓	✓	✓																2KJ3112 - ■ ■ A 0 ■ - 0 ■ N1
21.69	67	8 000	35 100	-	81	2494/115							✓	✓	✓	✓	✓	✓	✓																2KJ3112 - ■ ■ A 0 ■ - 0 ■ M1
19.33	75	8 000	33 500	-	96	58/3							✓	✓	✓	✓	✓	✓	✓	✓															2KJ3112 - ■ ■ A 0 ■ - 0 ■ L1
17.15	85	8 000	32 000	-	113	1972/115							✓	✓	✓	✓	✓	✓	✓	✓															2KJ3112 - ■ ■ A 0 ■ - 0 ■ K1
15.74	92	8 000	30 900	-	127	551/35							✓	✓	✓	✓	✓	✓	✓	✓															2KJ3112 - ■ ■ A 0 ■ - 0 ■ J1
13.87	105	8 000	29 300	-	150	319/23								✓	✓	✓	✓	✓	✓	✓															2KJ3112 - ■ ■ A 0 ■ - 0 ■ H1
11.38	127	8 000	28 700	-	203	1479/130								✓	✓	✓	✓	✓	✓	✓															2KJ3112 - ■ ■ A 0 ■ - 0 ■ G1
9.98	145	8 000	28 400	-	227	1247/125								✓	✓	✓	✓	✓	✓	✓															2KJ3112 - ■ ■ A 0 ■ - 0 ■ F1
7.80	186	8 000	27 500	-	360	39/5								✓	✓	✓	✓	✓	✓	✓															2KJ3112 - ■ ■ A 0 ■ - 0 ■ E1
7.27	199	5 460	27 500	-	173	836/115								✓	✓	✓	✓	✓	✓	✓															2KJ3112 - ■ ■ A 0 ■ - 0 ■ D1
5.96	243	5 460	26 600	-	237	1938/325								✓	✓	✓	✓	✓	✓	✓															2KJ3112 - ■ ■ A 0 ■ - 0 ■ C1
5.23	277	5 430	26 000	-	273	3268/625								✓	✓	✓	✓	✓	✓	✓															2KJ3112 - ■ ■ A 0 ■ - 0 ■ B1
4.09	355	5 360	24 700	-	432	2964/725								✓	✓	✓	✓	✓	✓	✓															2KJ3112 - ■ ■ A 0 ■ - 0 ■ A1

1) Only in conjunction with reduced-backlash version

Article No. supplement

Shaft design	→ Page 9/39																										1 or 9												
Adapter size	K4	B	C	D	E	F	G	H	J	K	L	M	N																						4				
	K2			D	E	F	G	H	J	K	L	M	N	P	Q																				2				
	KQ	A	B	C		D	E																												7				
	K8					A	B		C		D	E	F																						8				
	K5	A	B	C		D	E		F	G	H																								5				
	K3	A		B	C		D	E		F	G	H																							3				
Adapter type																																							
Gearbox mounting type	→ Page 9/34																										A, B, F or H												

Selection and ordering data

Gearbox							Adapter											Article No.						
<i>i</i>	<i>n</i> ₂	<i>T</i> _{2N}	<i>F</i> _{R2}	ϕ ¹⁾	<i>J</i> _G	<i>R</i> _{ex}	K4	63	71	80	90	100	112	132	160	180	200	225	250				(Article No. supplement → below)	
-	rpm	Nm	N	'	10 ⁻⁴	-	K2			80	90	100	112	132	160	180	200	225	250	280	315			
							KQ	703	704	706		708	710											
							K8					808	810		813		816			818	822			
							K5	56		140	180		210	250		280	320	360						
							K3	56		140	180		210	250		280	320	360						
D.169																								
327.18	4.4	14 000	70 100	-	18	472768 / 1445							✓	✓	✓								2KJ3213 - ■ ■ A 0 ■ - 0 ■ V1	
305.28	4.7	14 000	70 100	-	19	233536 / 765							✓	✓	✓								2KJ3213 - ■ ■ A 0 ■ - 0 ■ U1	
271.40	5.3	14 000	70 100	-	23	115344 / 425							✓	✓	✓								2KJ3213 - ■ ■ A 0 ■ - 0 ■ T1	
243.68	6.0	14 000	70 100	-	28	45568 / 187							✓	✓	✓								2KJ3213 - ■ ■ A 0 ■ - 0 ■ S1	
220.58	6.6	14 000	70 100	-	33	56248 / 255							✓	✓	✓								2KJ3213 - ■ ■ A 0 ■ - 0 ■ R1	
193.75	7.5	14 000	70 100	-	40	378784 / 1955							✓	✓	✓								2KJ3213 - ■ ■ A 0 ■ - 0 ■ Q1	
175.57	8.3	14 000	70 100	-	46	373088 / 2125							✓	✓	✓	✓							2KJ3213 - ■ ■ A 0 ■ - 0 ■ P1	
156.36	9.3	14 000	70 100	-	54	39872 / 255							✓	✓	✓	✓	✓						2KJ3213 - ■ ■ A 0 ■ - 0 ■ N1	
140.41	10.3	14 000	70 100	-	64	250624 / 1785							✓	✓	✓	✓	✓	✓					2KJ3213 - ■ ■ A 0 ■ - 0 ■ M1	
125.28	11.6	14 000	70 100	-	74	244928 / 1955							✓	✓	✓	✓	✓	✓					2KJ3213 - ■ ■ A 0 ■ - 0 ■ L1	
111.69	13	14 000	70 100	-	85	5696 / 51							✓	✓	✓	✓	✓	✓	✓				2KJ3213 - ■ ■ A 0 ■ - 0 ■ K1	
99.06	14.6	14 000	70 100	-	101	11392 / 115							✓	✓	✓	✓	✓	✓	✓				2KJ3213 - ■ ■ A 0 ■ - 0 ■ J1	
90.94	15.9	14 000	70 100	-	112	54112 / 595							✓	✓	✓	✓	✓	✓	✓				2KJ3213 - ■ ■ A 0 ■ - 0 ■ H1	
80.12	18.1	14 000	70 100	-	132	31328 / 391							✓	✓	✓	✓	✓	✓	✓				2KJ3213 - ■ ■ A 0 ■ - 0 ■ G1	
65.72	22	14 000	70 100	-	176	4272 / 65							✓	✓	✓	✓	✓	✓	✓				2KJ3213 - ■ ■ A 0 ■ - 0 ■ F1	
57.63	25	14 000	70 100	-	193	122464 / 2125							✓	✓	✓	✓	✓	✓	✓				2KJ3213 - ■ ■ A 0 ■ - 0 ■ E1	
45.06	32	14 000	70 100	-	301	111072 / 2465							✓	✓	✓	✓	✓	✓	✓				2KJ3213 - ■ ■ A 0 ■ - 0 ■ D1	
41.43	35	14 000	70 100	-	200	134657 / 3250							✓	✓	✓	✓	✓	✓	✓				2KJ3213 - ■ ■ A 0 ■ - 0 ■ C1	
36.33	40	14 000	70 400	-	225	340603 / 9375							✓	✓	✓	✓	✓	✓	✓				2KJ3213 - ■ ■ A 0 ■ - 0 ■ B1	
28.41	51	14 000	69 300	-	353	102973 / 3625							✓	✓	✓	✓	✓	✓	✓				2KJ3213 - ■ ■ A 0 ■ - 0 ■ A1	

1) Only in conjunction with reduced-backlash version

Article No. supplement		1 or 9																						
Shaft design	→ Page 9/39																							
Adapter size		K4	B	C	D	E	F	G	H	J	K	L	M	N									4	
		K2			D	E	F	G	H	J	K	L	M	N	P	Q								2
		KQ	A	B	C		D	E																7
		K8					A	B		C		D		E	F									8
		K5	A		B	C		D	E		F	G	H											5
		K3	A		B	C		D	E		F	G	H											3
Adapter type																								
Gearbox mounting type	→ Page 9/34	A, B, F or H																						

SIMOGEAR Gearboxes

Helical gearboxes

Transmission ratios and torques

Selection and ordering data

Gearbox							Adapter											Article No.					
i	n_2	T_{2N}	F_{R2}	$\phi^{1)}$	J_G	R_{ex}	K4	63	71	80	90	100	112	132	160	180	200	225	250			(Article No. supplement → below)	
-	rpm	Nm	N	'	10^{-4}	-	K2			80	90	100	112	132	160	180	200	225	250	280	315		
							KQ		703	704	706		708	710									
							K8						808	810		813		816			818	822	
							K5		56		140	180		210	250		280	320	360				
							K3		56		140	180		210	250		280	320	360				

Z.169

Ratio	n_2	T_{2N}	F_{R2}	$\phi^{1)}$	J_G	R_{ex}	Adapter	Article No.
36.55	40	12 100	70 800	-	79	13706/375	✓ ✓ ✓ ✓	2KJ3113 - ■ ■ A 0 ■ - 0 ■ Q1
32.88	44	14 000	68 300	-	94	11837/360	✓ ✓ ✓ ✓ ✓	2KJ3113 - ■ ■ A 0 ■ - 0 ■ P1
29.38	49	14 000	65 500	-	109	9256/315	✓ ✓ ✓ ✓ ✓ ✓	2KJ3113 - ■ ■ A 0 ■ - 0 ■ N1
26.57	55	14 000	63 000	-	131	9167/345	✓ ✓ ✓ ✓ ✓ ✓	2KJ3113 - ■ ■ A 0 ■ - 0 ■ M1
23.45	62	14 000	60 200	-	154	7387/315	✓ ✓ ✓ ✓ ✓ ✓ ✓ ✓	2KJ3113 - ■ ■ A 0 ■ - 0 ■ L1
20.90	69	14 000	59 400	-	183	2403/115	✓ ✓ ✓ ✓ ✓ ✓ ✓ ✓	2KJ3113 - ■ ■ A 0 ■ - 0 ■ K1
18.93	77	14 000	58 700	-	203	5963/315	✓ ✓ ✓ ✓ ✓ ✓ ✓ ✓	2KJ3113 - ■ ■ A 0 ■ - 0 ■ J1
17.03	85	14 000	57 800	-	245	1958/115	✓ ✓ ✓ ✓ ✓ ✓ ✓ ✓	2KJ3113 - ■ ■ A 0 ■ - 0 ■ H1
14.15	102	14 000	56 100	-	308	2759/195	✓ ✓ ✓ ✓ ✓ ✓ ✓ ✓	2KJ3113 - ■ ■ A 0 ■ - 0 ■ G1
12.58	115	13 900	55 000	-	377	4717/375	✓ ✓ ✓ ✓ ✓ ✓ ✓ ✓	2KJ3113 - ■ ■ A 0 ■ - 0 ■ F1
10.03	145	13 900	52 600	-	521	4361/435	✓ ✓ ✓ ✓ ✓ ✓ ✓ ✓	2KJ3113 - ■ ■ A 0 ■ - 0 ■ E1
7.98	182	13 800	50 200	-	689	1157/145	✓ ✓ ✓ ✓ ✓ ✓ ✓ ✓	2KJ3113 - ■ ■ A 0 ■ - 0 ■ D1
7.37	197	7 960	49 200	-	409	848/115	✓ ✓ ✓ ✓ ✓ ✓ ✓ ✓	2KJ3113 - ■ ■ A 0 ■ - 0 ■ C1
5.88	247	7 900	46 700	-	571	3920/667	✓ ✓ ✓ ✓ ✓ ✓ ✓ ✓	2KJ3113 - ■ ■ A 0 ■ - 0 ■ B1
4.68	310	7 820	44 200	-	768	3120/667	✓ ✓ ✓ ✓ ✓ ✓ ✓ ✓	2KJ3113 - ■ ■ A 0 ■ - 0 ■ A1

¹⁾ Only in conjunction with reduced-backlash version

Article No. supplement

Shaft design	→ Page 9/39	1 or 9																					
Adapter size		K4	B	C	D	E	F	G	H	J	K	L	M	N									4
		K2			D	E	F	G	H	J	K	L	M	N	P	Q							2
		KQ	A	B	C		D	E															7
		K8					A	B		C		D		E	F								8
		K5	A		B	C		D	E		F	G	H										5
		K3	A		B	C		D	E		F	G	H										3
Adapter type																							
Gearbox mounting type	→ Page 9/34		A, B, F or H																				

Selection and ordering data

Gearbox							Adapter											Article No.						
<i>i</i>	<i>n</i> ₂	<i>T</i> _{2N}	<i>F</i> _{R2}	ϕ ¹⁾	<i>J</i> _G	<i>R</i> _{ex}	K4	63	71	80	90	100	112	132	160	180	200	225	250				(Article No. supplement → below)	
-	rpm	Nm	N	'	10 ⁻⁴	-	K2			80	90	100	112	132	160	180	200	225	250	280	315			
							KQ	703	704	706		708	710											
							K8					808	810		813		816			818	822			
							K5	56		140	180		210	250		280	320	360						
							K3	56		140	180		210	250		280	320	360						
D.189																								
313.63	4.6	19 000	107 000	-	36	533169/1700							✓	✓	✓									2KJ3214 - ■ ■ A 0 ■ - 0 ■ T1
280.59	5.2	19 000	107 000	-	43	262353/935							✓	✓	✓									2KJ3214 - ■ ■ A 0 ■ - 0 ■ S1
253.06	5.7	19 000	107 000	-	49	172081/680							✓	✓	✓									2KJ3214 - ■ ■ A 0 ■ - 0 ■ R1
223.66	6.5	19 000	107 000	-	61	87451/391							✓	✓	✓									2KJ3214 - ■ ■ A 0 ■ - 0 ■ Q1
204.44	7.1	19 000	107 000	-	71	434434/2125							✓	✓	✓	✓								2KJ3214 - ■ ■ A 0 ■ - 0 ■ P1
183.92	7.9	19 000	107 000	-	84	375193/2040							✓	✓	✓	✓	✓							2KJ3214 - ■ ■ A 0 ■ - 0 ■ N1
164.36	8.8	19 000	107 000	-	98	41912/255							✓	✓	✓	✓	✓	✓						2KJ3214 - ■ ■ A 0 ■ - 0 ■ M1
148.63	9.8	19 000	107 000	-	116	290563/1955							✓	✓	✓	✓	✓	✓						2KJ3214 - ■ ■ A 0 ■ - 0 ■ L1
131.17	11	19 000	107 000	-	136	33449/255							✓	✓	✓	✓	✓	✓	✓					2KJ3214 - ■ ■ A 0 ■ - 0 ■ K1
116.88	12	19 000	107 000	-	160	228501/1955							✓	✓	✓	✓	✓	✓	✓					2KJ3214 - ■ ■ A 0 ■ - 0 ■ J1
105.89	14	19 000	107 000	-	175	27001/255							✓	✓	✓	✓	✓	✓	✓					2KJ3214 - ■ ■ A 0 ■ - 0 ■ H1
95.24	15	19 000	107 000	-	210	186186/1955							✓	✓	✓	✓	✓	✓	✓					2KJ3214 - ■ ■ A 0 ■ - 0 ■ G1
79.14	18	19 000	107 000	-	257	6727/85							✓	✓	✓	✓	✓	✓	✓					2KJ3214 - ■ ■ A 0 ■ - 0 ■ F1
70.36	21	19 000	107 000	-	314	149513/2125							✓	✓	✓	✓	✓	✓	✓					2KJ3214 - ■ ■ A 0 ■ - 0 ■ E1
56.08	26	19 000	107 000	-	421	138229/2465							✓	✓	✓	✓	✓	✓	✓					2KJ3214 - ■ ■ A 0 ■ - 0 ■ D1
44.63	32	19 000	107 000	-	531	110019/2465									✓	✓	✓	✓	✓					2KJ3214 - ■ ■ A 0 ■ - 0 ■ C1
36.67	40	19 000	104 400	-	475	10633/290							✓	✓	✓	✓	✓	✓	✓					2KJ3214 - ■ ■ A 0 ■ - 0 ■ B1
29.18	50	19 000	97 900	-	617	8463/290									✓	✓	✓	✓	✓					2KJ3214 - ■ ■ A 0 ■ - 0 ■ A1

1) Only in conjunction with reduced-backlash version

Article No. supplement		1 or 9																						
Shaft design	→ Page 9/39																							
Adapter size		K4	B	C	D	E	F	G	H	J	K	L	M	N									4	
		K2			D	E	F	G	H	J	K	L	M	N	P	Q								2
		KQ	A	B	C		D	E																7
		K8					A	B		C		D		E	F									8
		K5	A		B	C		D	E		F	G	H											5
		K3	A		B	C		D	E		F	G	H											3
Adapter type																								
Gearbox mounting type	→ Page 9/34	A, B, F or H																						



SIMOGEAR Gearboxes

Helical gearboxes

Transmission ratios and torques

Selection and ordering data

Gearbox							Adapter										Article No.						
<i>i</i>	<i>n</i> ₂	<i>T</i> _{2N}	<i>F</i> _{R2}	ϕ ¹⁾	<i>J</i> _G	<i>R</i> _{ex}	K4	63	71	80	90	100	112	132	160	180	200	225	250			(Article No. supplement → below)	
-	rpm	Nm	N	'	10 ⁻⁴	-	K2			80	90	100	112	132	160	180	200	225	250	280	315		
							KQ	703	704	706		708	710										
							K8					808	810		813		816			818	822		
							K5	56		140	180		210	250		280	320	360					
							K3	56		140	180		210	250		280	320	360					
Z.189																							
34.25	42	19 000	102 000	-	140	3596/105							✓	✓	✓	✓	✓	✓					2KJ3114 - ■ ■ A 0 ■ - 0 ■ L1
30.73	47	19 000	98 100	-	166	3534/115							✓	✓	✓	✓	✓	✓					2KJ3114 - ■ ■ A 0 ■ - 0 ■ K1
27.46	53	19 000	94 300	-	199	961/35							✓	✓	✓	✓	✓	✓	✓	✓			2KJ3114 - ■ ■ A 0 ■ - 0 ■ J1
24.53	59	19 000	90 600	-	236	2821/115							✓	✓	✓	✓	✓	✓	✓	✓			2KJ3114 - ■ ■ A 0 ■ - 0 ■ H1
22.44	65	19 000	87 700	-	262	2356/105							✓	✓	✓	✓	✓	✓	✓	✓	✓		2KJ3114 - ■ ■ A 0 ■ - 0 ■ G1
19.95	73	19 000	84 100	-	314	2294/115							✓	✓	✓	✓	✓	✓	✓	✓	✓		2KJ3114 - ■ ■ A 0 ■ - 0 ■ F1
16.93	86	19 000	79 200	-	400	2201/130							✓	✓	✓	✓	✓	✓	✓	✓	✓		2KJ3114 - ■ ■ A 0 ■ - 0 ■ E1
14.63	99	19 000	75 000	-	481	1829/125							✓	✓	✓	✓	✓	✓	✓	✓	✓		2KJ3114 - ■ ■ A 0 ■ - 0 ■ D1
11.97	121	19 000	72 600	-	666	1736/145							✓	✓	✓	✓	✓	✓	✓	✓	✓		2KJ3114 - ■ ■ A 0 ■ - 0 ■ C1
9.83	148	18 800	70 200	-	875	1426/145									✓	✓	✓	✓	✓	✓	✓		2KJ3114 - ■ ■ A 0 ■ - 0 ■ B1
7.65	190	16 000	66 900	-	1 283	1147/150													✓	✓	✓		2KJ3114 - ■ ■ A 0 ■ - 0 ■ A1

1) Only in conjunction with reduced-backlash version

Article No. supplement		1 or 9																						
Shaft design	→ Page 9/39																							
Adapter size		K4	B	C	D	E	F	G	H	J	K	L	M	N									4	
		K2			D	E	F	G	H	J	K	L	M	N	P	Q								2
		KQ	A	B	C		D	E															7	
		K8					A	B		C		D		E	F								8	
		K5	A		B	C		D	E		F	G	H										5	
		K3	A		B	C		D	E		F	G	H										3	
Adapter type																								
Gearbox mounting type	→ Page 9/34	A, B, F or H																						

Dimensional drawing overview

 Information about dimensional drawings can be found in Chapter [Introduction on page 1/20](#).

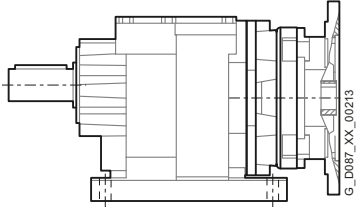
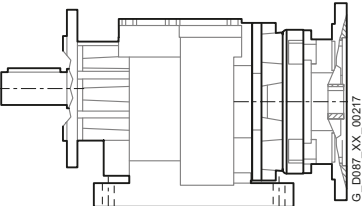
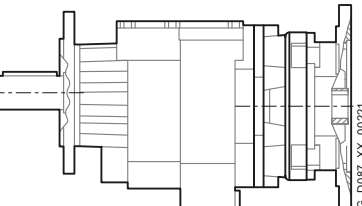
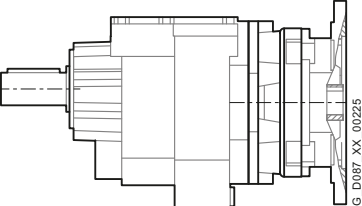
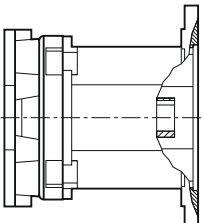
Representation	Gearbox type	Dimensional drawing on page
Helical gearbox with adapter K4		
<i>Foot-mounted design</i>		
	D/Z29	3/30
	D/Z39	3/34
	D/Z49	3/38
	D/Z59	3/41
	D/Z69	3/44
	D/Z79	3/47
	D/Z89	3/50
	D/Z109	3/53
	D/Z129	3/56
	D/Z149	3/59
D/Z169	3/61	
D/Z189	3/63	
<i>Foot/flange-mounted design</i>		
	DB/ZB29	3/31
	DB/ZB39	3/35
	DB/ZB49	3/38
	DB/ZB59	3/41
	DB/ZB69	3/44
	DB/ZB79	3/47
DB/ZB89	3/50	
<i>Flange-mounted design</i>		
	DF/ZF29	3/32
	DF/ZF39	3/36
	DF/ZF49	3/39
	DF/ZF59	3/42
	DF/ZF69	3/45
	DF/ZF79	3/48
	DF/ZF89	3/51
	DF/ZF109	3/54
	DF/ZF129	3/57
	DF/ZF149	3/60
DF/ZF169	3/62	
DF/ZF189	3/64	
<i>Housing flange design</i>		
	DZ/ZZ29	3/33
	DZ/ZZ39	3/37
	DZ/ZZ49	3/40
	DZ/ZZ59	3/43
	DZ/ZZ69	3/46
	DZ/ZZ79	3/49
	DZ/ZZ89	3/52
	DZ/ZZ109	3/55
DZ/ZZ129	3/58	
Helical gearbox with adapter K2		
	D./Z.29 ... D./Z.189	3/65

SIMOGEAR Gearboxes

Helical gearboxes

Dimensions

Dimensional drawing overview (continued)

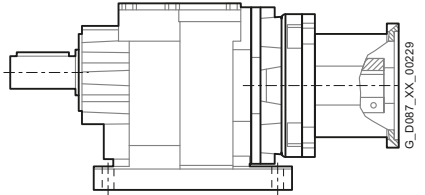
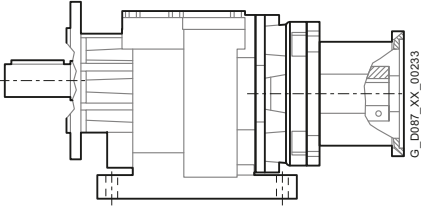
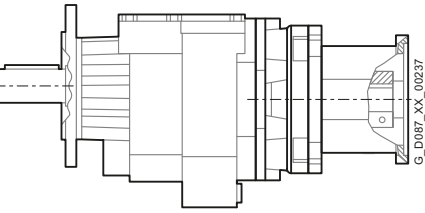
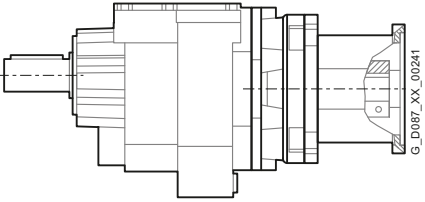
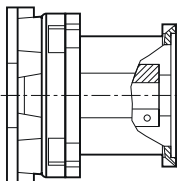
Representation	Gearbox type	Dimensional drawing on page
Helical gearbox with adapter KQ		
<i>Foot-mounted design</i>		
	D/Z29	3/68
	D/Z39	3/72
	D/Z49	3/76
	D/Z59	3/79
	D/Z69	3/82
	D/Z79	3/85
	D/Z89	3/88
	D/Z109	3/91
	D/Z129	3/94
	D/Z149	3/97
	D/Z169	3/99
	D/Z189	3/101
	<i>Foot/flange-mounted design</i>	
	DB/ZB29	3/69
	DB/ZB39	3/73
	DB/ZB49	3/76
	DB/ZB59	3/79
	DB/ZB69	3/82
	DB/ZB79	3/85
	DB/ZB89	3/88
<i>Flange-mounted design</i>		
	DF/ZF29	3/70
	DF/ZF39	3/74
	DF/ZF49	3/77
	DF/ZF59	3/80
	DF/ZF69	3/83
	DF/ZF79	3/86
	DF/ZF89	3/89
	DF/ZF109	3/92
	DF/ZF129	3/95
	DF/ZF149	3/98
DF/ZF169	3/100	
DF/ZF189	3/102	
<i>Housing flange design</i>		
	DZ/ZZ29	3/71
	DZ/ZZ39	3/75
	DZ/ZZ49	3/78
	DZ/ZZ59	3/81
	DZ/ZZ69	3/84
	DZ/ZZ79	3/87
	DZ/ZZ89	3/90
	DZ/ZZ109	3/93
	DZ/ZZ129	3/96
Helical gearbox with adapter KQS		
	D./Z.29 ... D./Z.189	3/103

Dimensional drawing overview (continued)

Representation	Gearbox type	Dimensional drawing on page
Helical gearbox with adapter K8	D./Z.29 ... D./Z.89	3/103

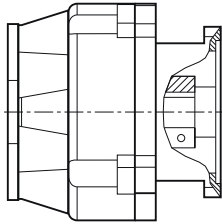
Helical gearbox with adapter K5

D./Z.29 ... D./Z.89

3/107

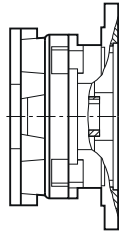

Helical gearbox with adapter K3

D./Z.29 ... D./Z.89

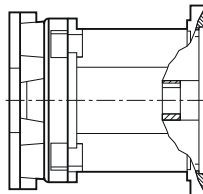
3/109

Additional versions and options

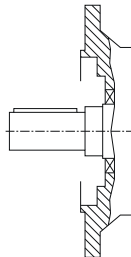
Inner contour of the flange design 3/111



SIMOGEAR Gearboxes

Helical gearbox with adapter K4

Dimensions

D/Z29 gearbox in a foot-mounted design

DZ030K4

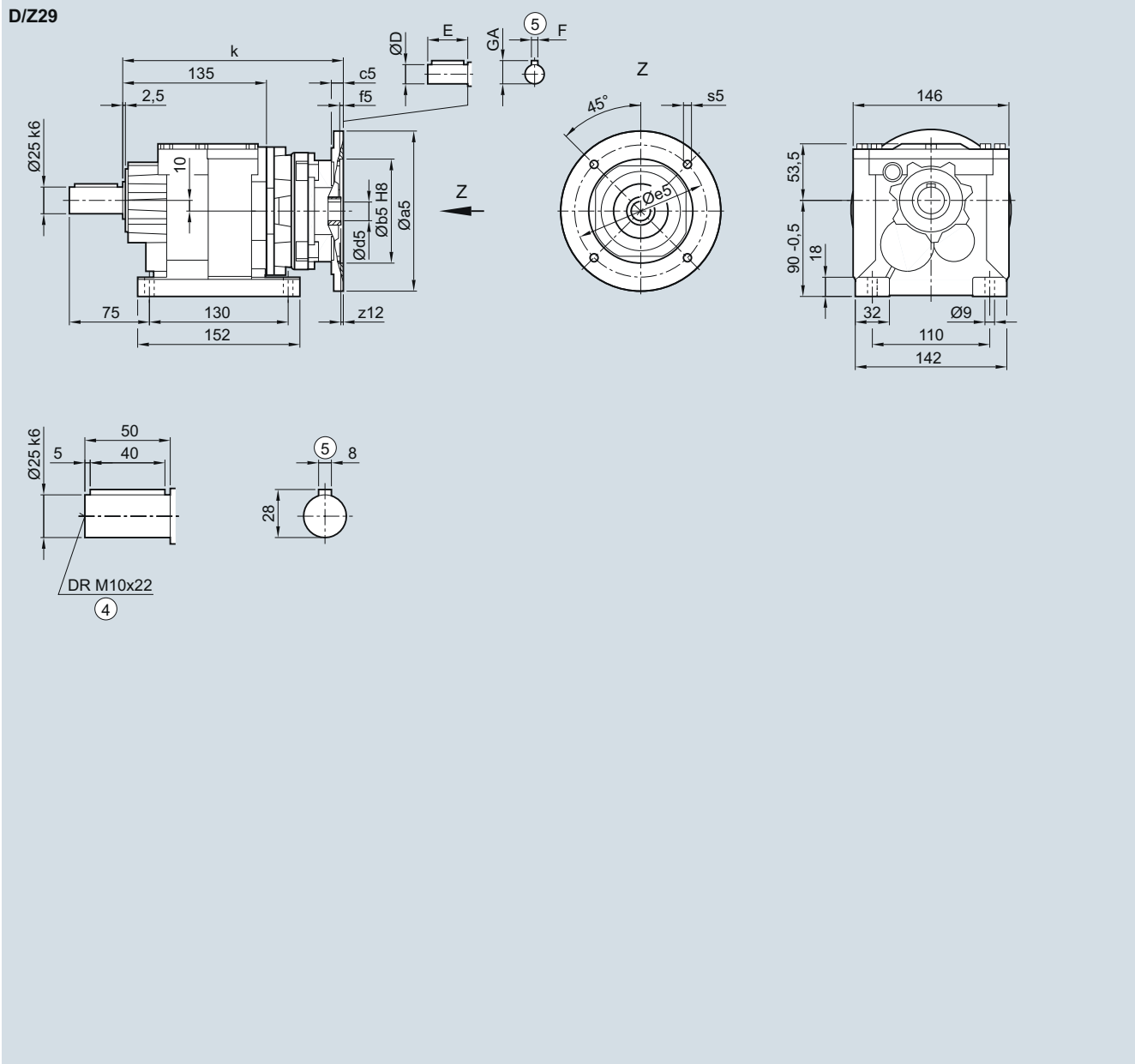

Adapter	a5	b5	c5	f5	e5	s5	z12	d5/D	E	F	GA	k
63	140	95	12	4.5	115	M8	2.5	11	23	4	12.5	212.5
71	160	110	12	4.5	130	M8	2.5	14	30	5	16.0	212.5
80	200	130	15	4.5	165	M10	4.0	19	40	6	21.5	240.5
90	200	130	15	4.5	165	M10	4.0	24	50	8	27.0	240.5
100	250	180	14	5.0	215	M12x21	7.5	28	60	8	31.0	295.0

④ DIN 332

⑤ Feather key/keyway DIN 6885

SIMOGEAR Gearboxes

Helical gearbox with adapter K4

Dimensions

DB/ZB29 gearbox in a foot/flange-mounted design

DZB030K4

DB/ZB29

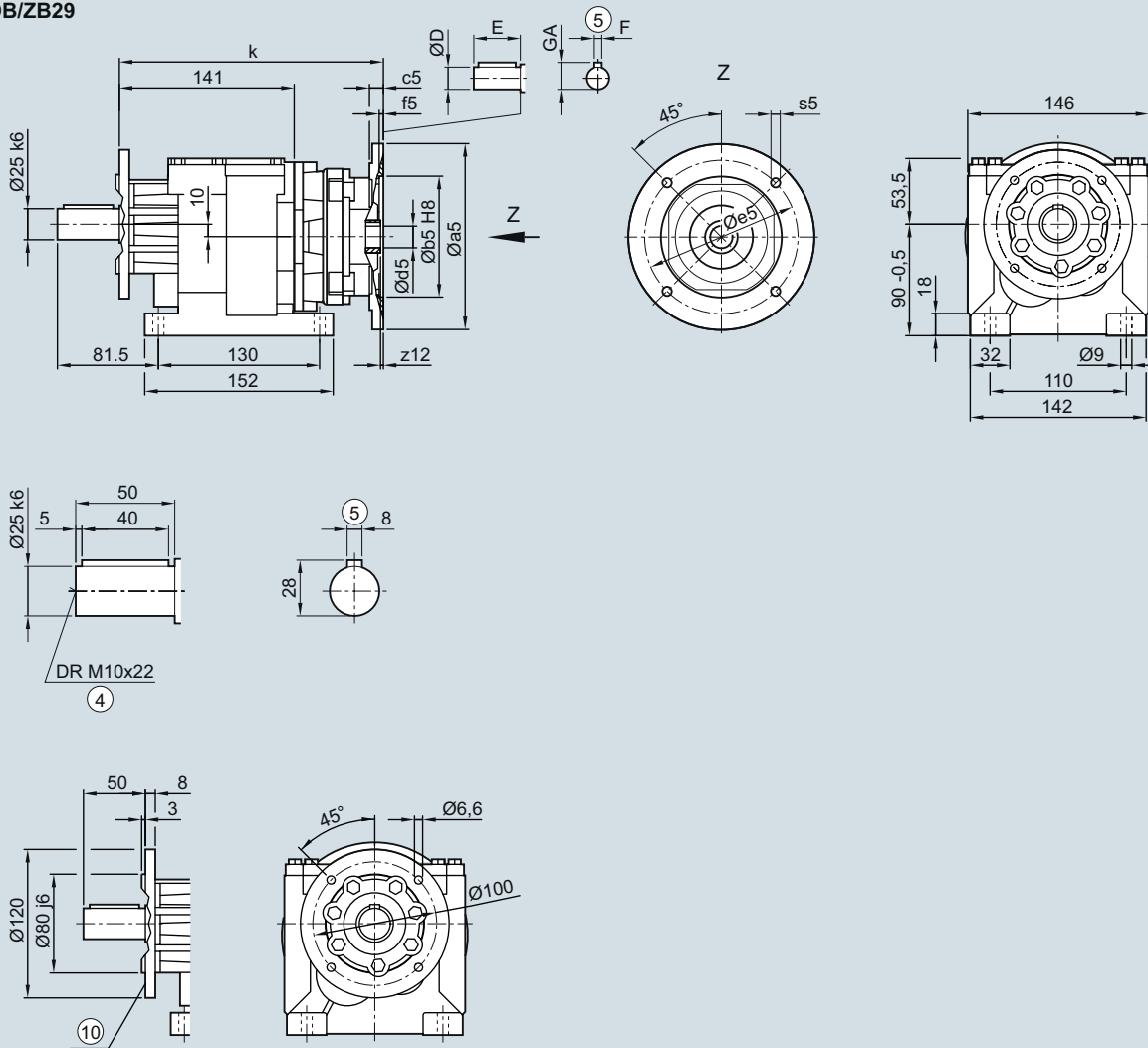

Adapter	a5	b5	c5	f5	e5	s5	z12	d5/D	E	F	GA	k
63	140	95	12	4.5	115	M8	2.5	11	23	4	12.5	218.5
71	160	110	12	4.5	130	M8	2.5	14	30	5	16.0	218.5
80	200	130	15	4.5	165	M10	4.0	19	40	6	21.5	246.5
90	200	130	15	4.5	165	M10	4.0	24	50	8	27.0	246.5
100	250	180	14	5.0	215	M12x21	7.5	28	60	8	31.0	301.0

④ DIN 332

Ⓜ For inner contour, see page 3/111

⑤ Feather key/keyway DIN 6885

SIMOGEAR Gearboxes

Helical gearbox with adapter K4

Dimensions

DF/ZF29 gearbox in a flange-mounted design

DZF030K4

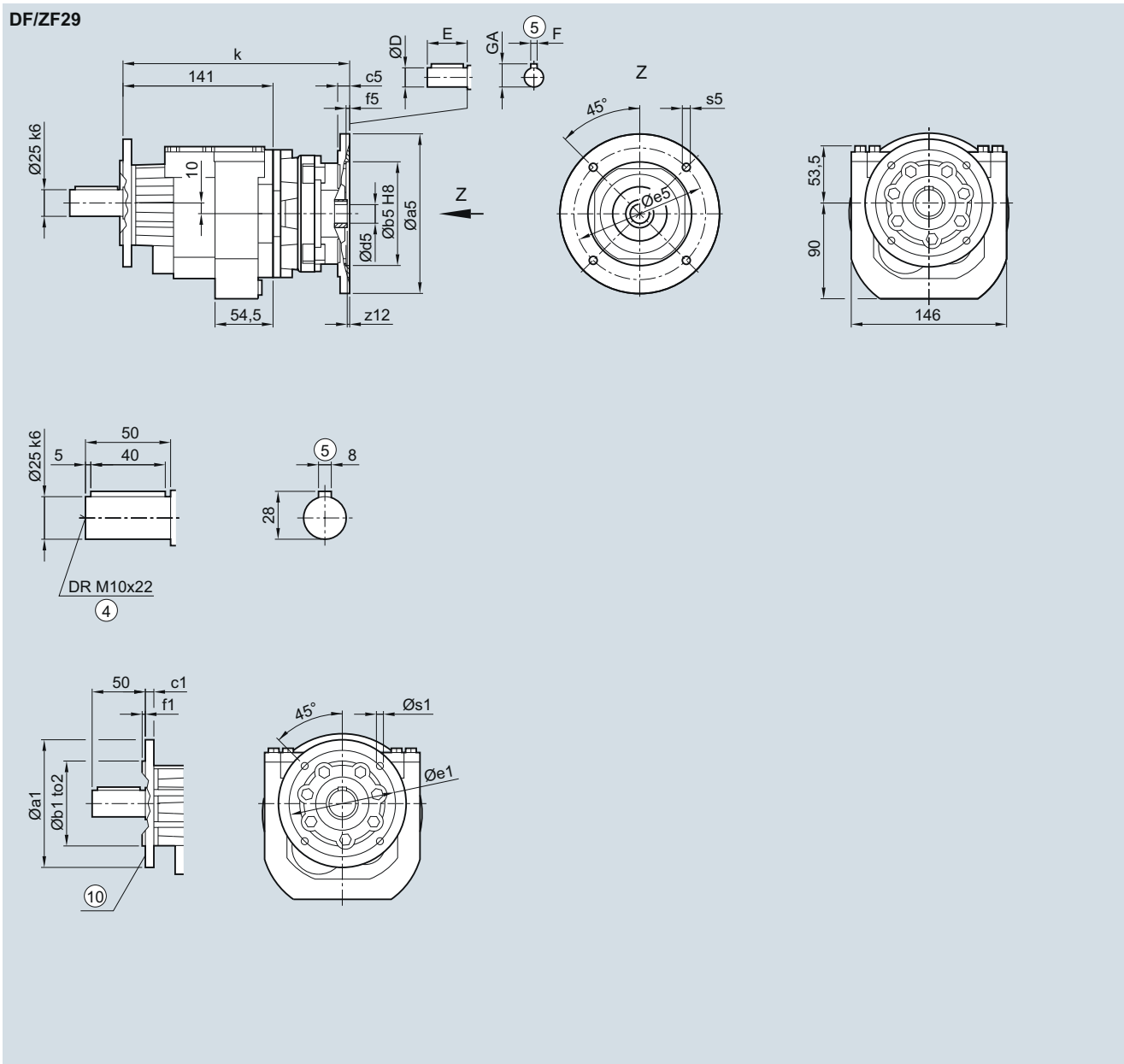

Flange	a1	b1	to2	c1	e1	f1	s1					
	120	80	j6	8	100	3.0	6.6					
	140	95	j6	9	115	3.0	9.0					
	160	110	j6	9	130	3.5	9.0					
Adapter	a5	b5	c5	f5	e5	s5	z12	d5/D	E	F	GA	k
63	140	95	12	4.5	115	M8	2.5	11	23	4	12.5	218.5
71	160	110	12	4.5	130	M8	2.5	14	30	5	16.0	218.5
80	200	130	15	4.5	165	M10	4.0	19	40	6	21.5	246.5
90	200	130	15	4.5	165	M10	4.0	24	50	8	27.0	246.5
100	250	180	14	5.0	215	M12x21	7.5	28	60	8	31.0	301.0

④ DIN 332

Ⓜ For inner contour, see page 3/111

⑤ Feather key/keyway DIN 6885

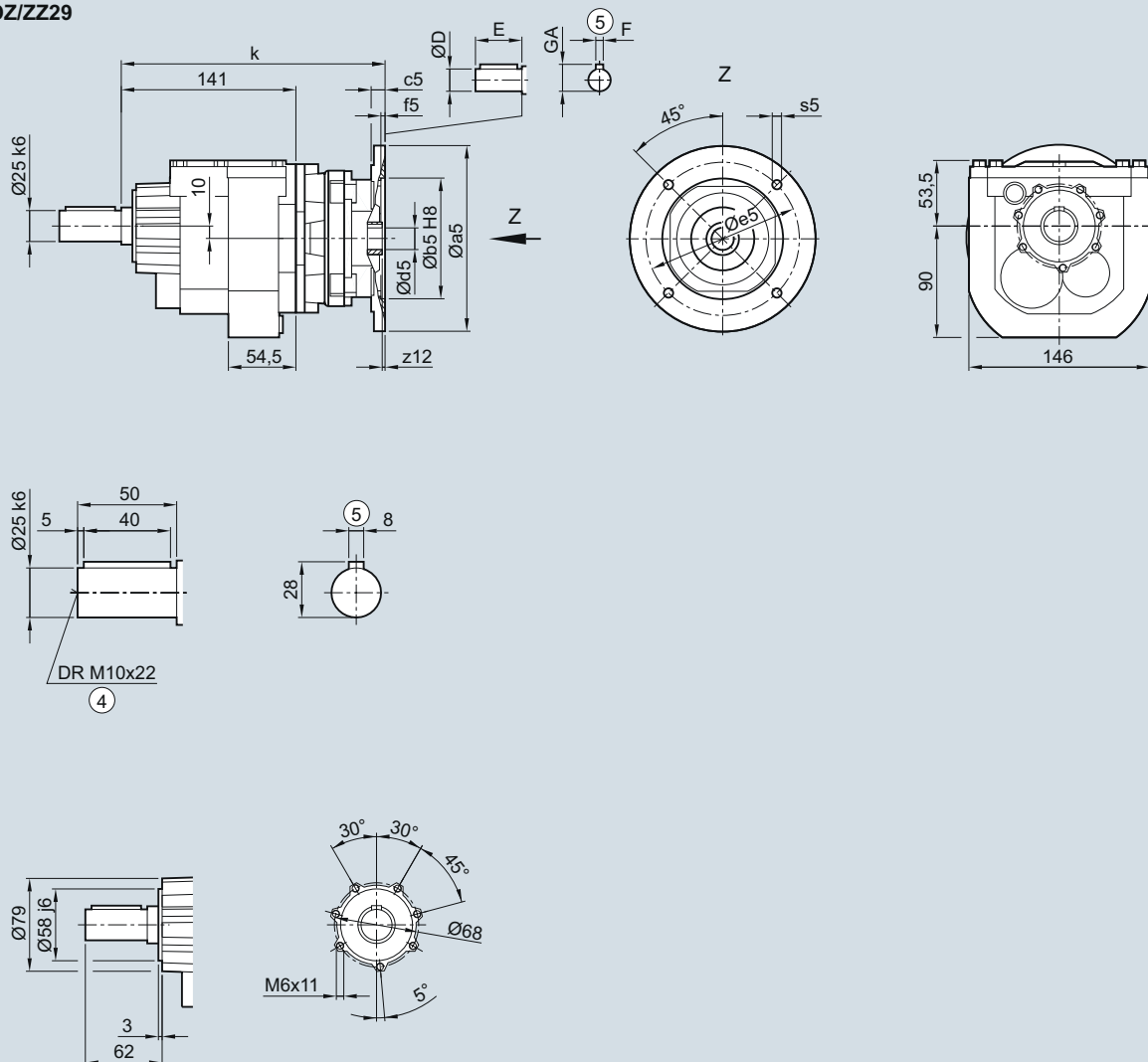
DZ/ZZ29 gearbox in a housing flange design
DZZ030K4
DZ/ZZ29

Adapter	a5	b5	c5	f5	e5	s5	z12	d5/D	E	F	GA	k
63	140	95	12	4.5	115	M8	2.5	11	23	4	12.5	218.5
71	160	110	12	4.5	130	M8	2.5	14	30	5	16.0	218.5
80	200	130	15	4.5	165	M10	4.0	19	40	6	21.5	246.5
90	200	130	15	4.5	165	M10	4.0	24	50	8	27.0	246.5
100	250	180	14	5.0	215	M12x21	7.5	28	60	8	31.0	301.0

Ⓒ DIN 332

Ⓔ Feather key/keyway DIN 6885

SIMOGEAR Gearboxes

Helical gearbox with adapter K4

Dimensions

D/Z39 gearbox in a foot-mounted design

DZ030K4

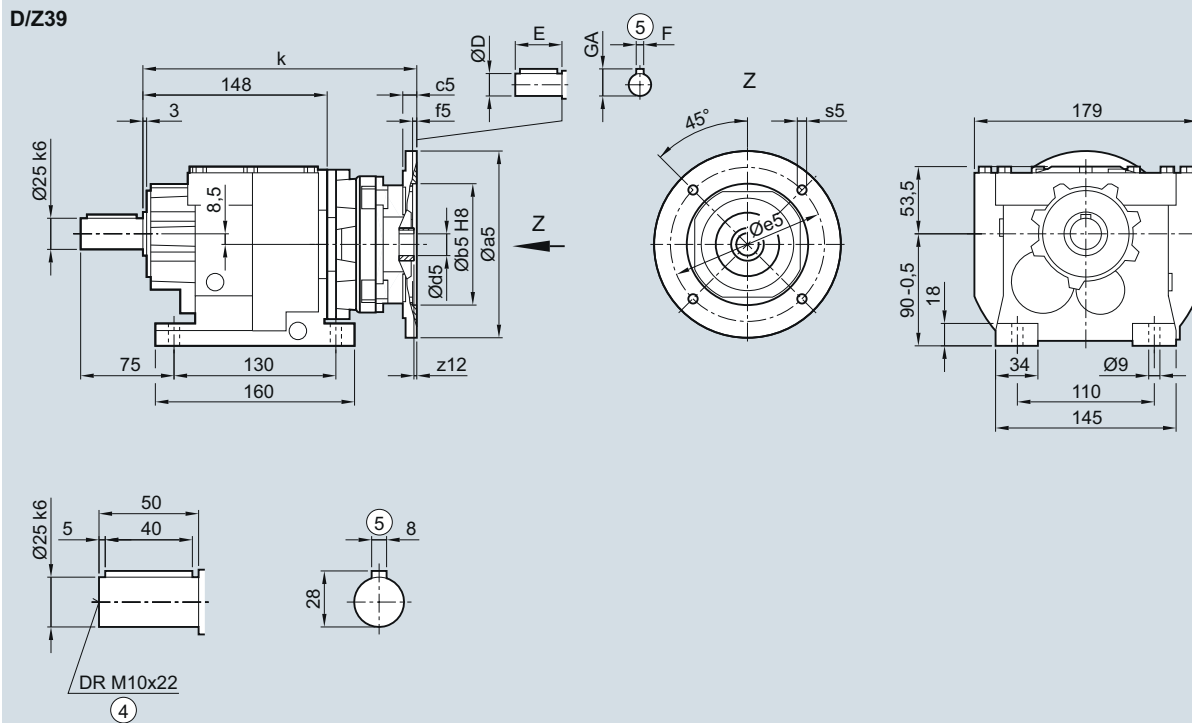

Adapter	a5	b5	c5	f5	e5	s5	z12	d5/D	E	F	GA	k
63	140	95	12	4.5	115	M8	2.5	11	23	4	12.5	225.5
71	160	110	12	4.5	130	M8	2.5	14	30	5	16.0	225.5
80	200	130	15	4.5	165	M10	4.0	19	40	6	21.5	253.5
90	200	130	15	4.5	165	M10	4.0	24	50	8	27.0	253.5
100	250	180	14	5.0	215	M12x21	7.5	28	60	8	31.0	308.0

④ DIN 332

⑤ Feather key/keyway DIN 6885

DB/ZB39 gearbox in a foot/flange-mounted design

DZB030K4

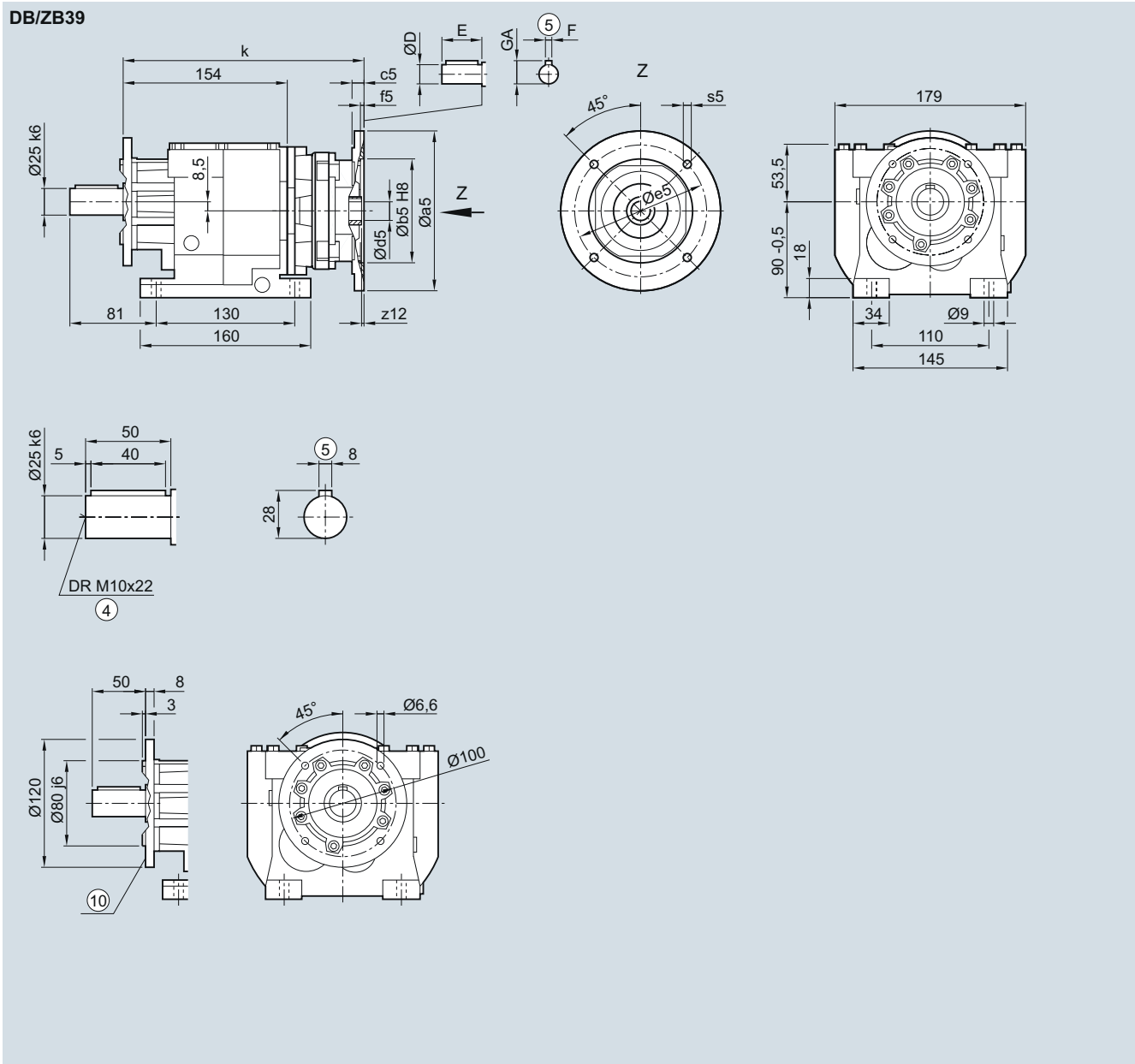

Adapter	a5	b5	c5	f5	e5	s5	z12	d5/D	E	F	GA	k
63	140	95	12	4.5	115	M8	2.5	11	23	4	12.5	231.5
71	160	110	12	4.5	130	M8	2.5	14	30	5	16.0	231.5
80	200	130	15	4.5	165	M10	4.0	19	40	6	21.5	259.5
90	200	130	15	4.5	165	M10	4.0	24	50	8	27.0	259.5
100	250	180	14	5.0	215	M12x21	7.5	28	60	8	31.0	314.0

④ DIN 332

Ⓜ For inner contour, see page 3/111

⑤ Feather key/keyway DIN 6885

SIMOGEAR Gearboxes

Helical gearbox with adapter K4

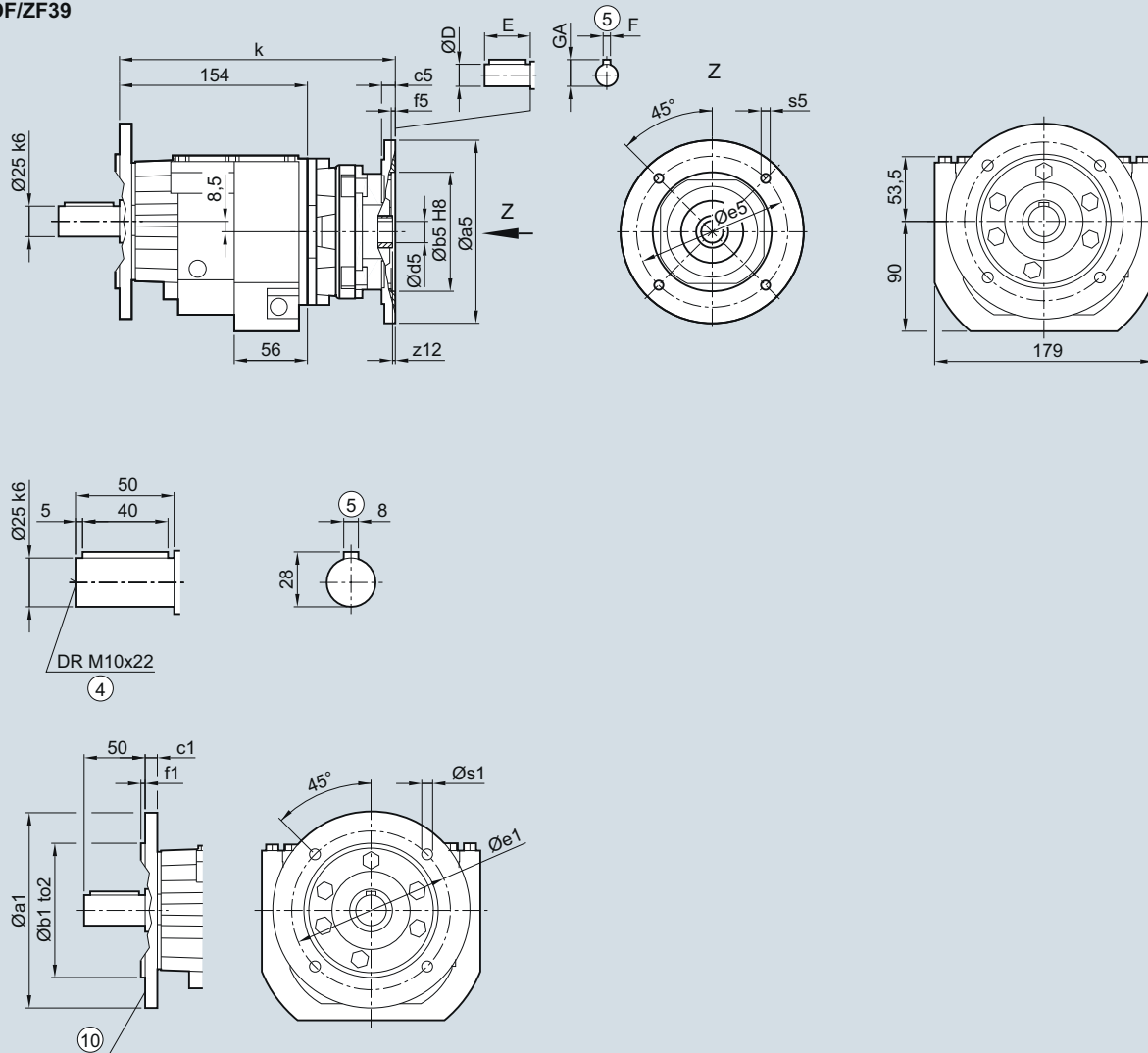
Dimensions**DF/ZF39 gearbox in a flange-mounted design****DZF030K4****DF/ZF39**

Flange	a1	b1	to2	c1	e1	f1	s1					
	120	80	j6	8	100	3.0	6.6					
	160	110	j6	10	130	3.5	9.0					
	200	130	j6	12	165	3.5	11.0					
Adapter	a5	b5	c5	f5	e5	s5	z12	d5/D	E	F	GA	k
63	140	95	12	4.5	115	M8	2.5	11	23	4	12.5	231.5
71	160	110	12	4.5	130	M8	2.5	14	30	5	16.0	231.5
80	200	130	15	4.5	165	M10	4.0	19	40	6	21.5	259.5
90	200	130	15	4.5	165	M10	4.0	24	50	8	27.0	259.5
100	250	180	14	5.0	215	M12x21	7.5	28	60	8	31.0	314.0

④ DIN 332

Ⓜ For inner contour, see page 3/111

⑤ Feather key/keyway DIN 6885

DZ/ZZ39 gearbox in a housing flange design

DZ030K4

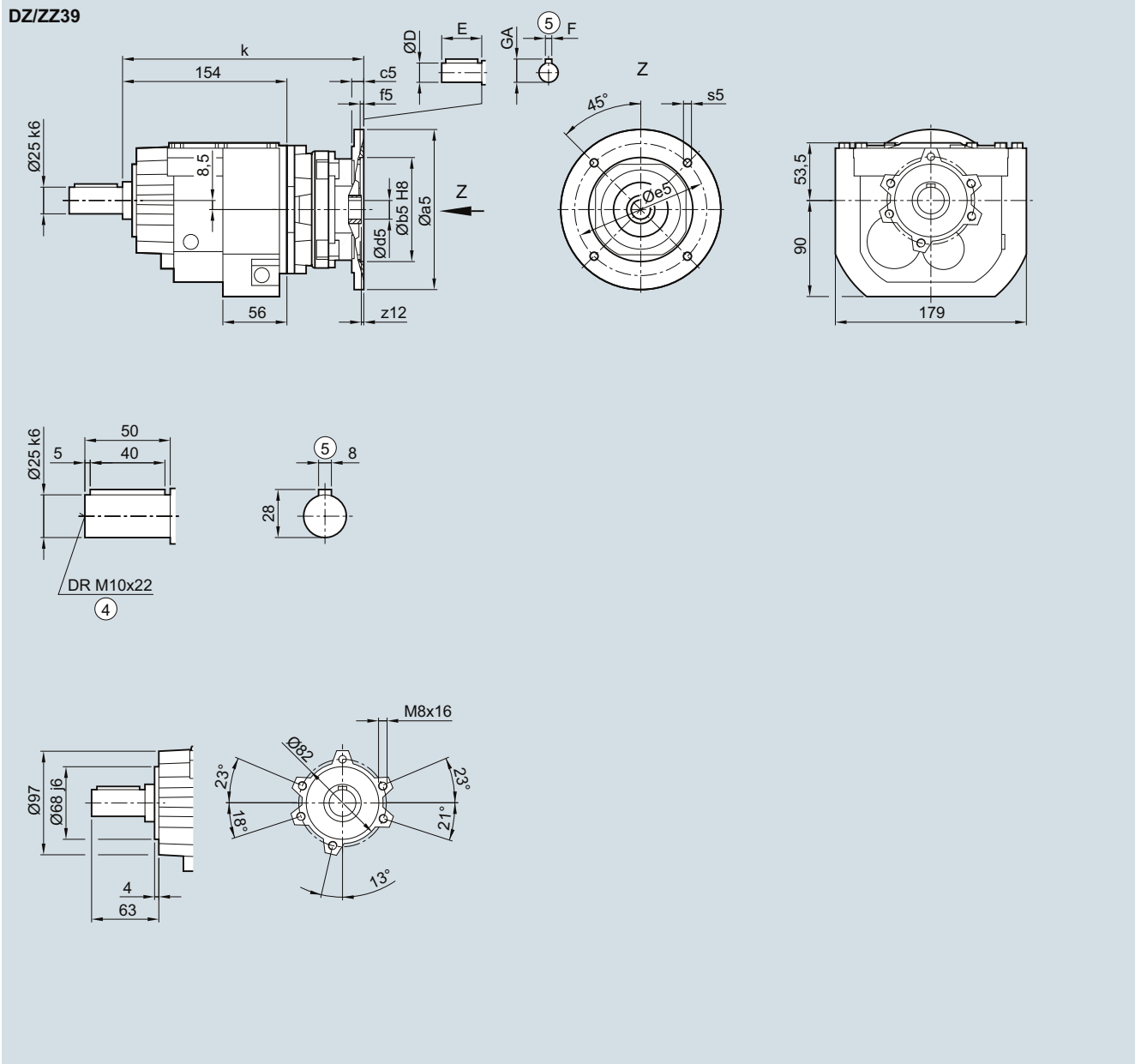

Adapter	a5	b5	c5	f5	e5	s5	z12	d5/D	E	F	GA	k
63	140	95	12	4.5	115	M8	2.5	11	23	4	12.5	231.5
71	160	110	12	4.5	130	M8	2.5	14	30	5	16.0	231.5
80	200	130	15	4.5	165	M10	4.0	19	40	6	21.5	259.5
90	200	130	15	4.5	165	M10	4.0	24	50	8	27.0	259.5
100	250	180	14	5.0	215	M12x21	7.5	28	60	8	31.0	314.0

④ DIN 332

⑤ Feather key/keyway DIN 6885

SIMOGEAR Gearboxes

Helical gearbox with adapter K4

Dimensions

D/Z49 and DB/ZB49 gearboxes in a foot and foot/flange-mounted design

DZ030K4, DZB030K4

D/Z49

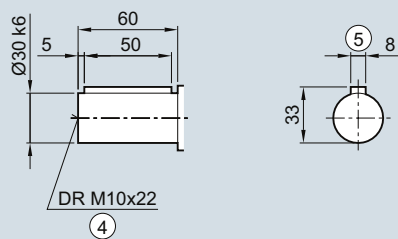
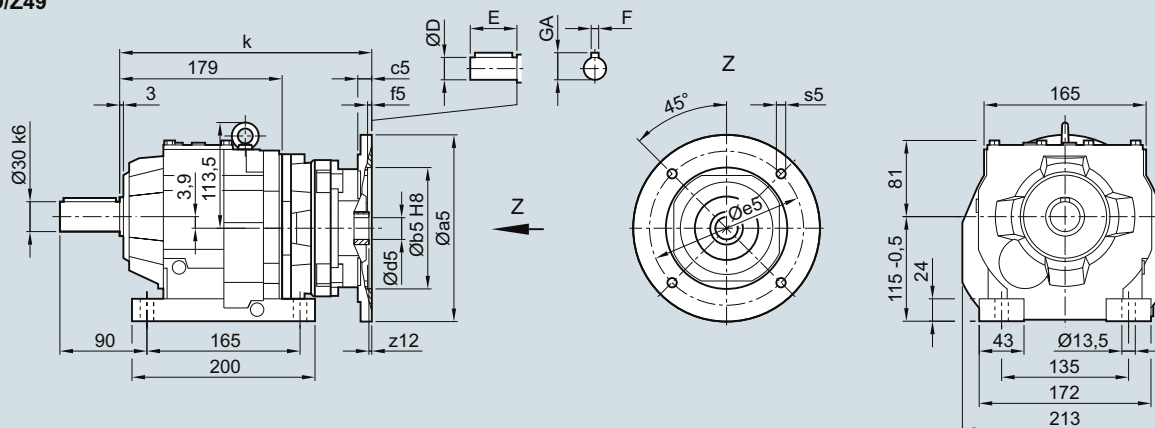

DB/ZB49

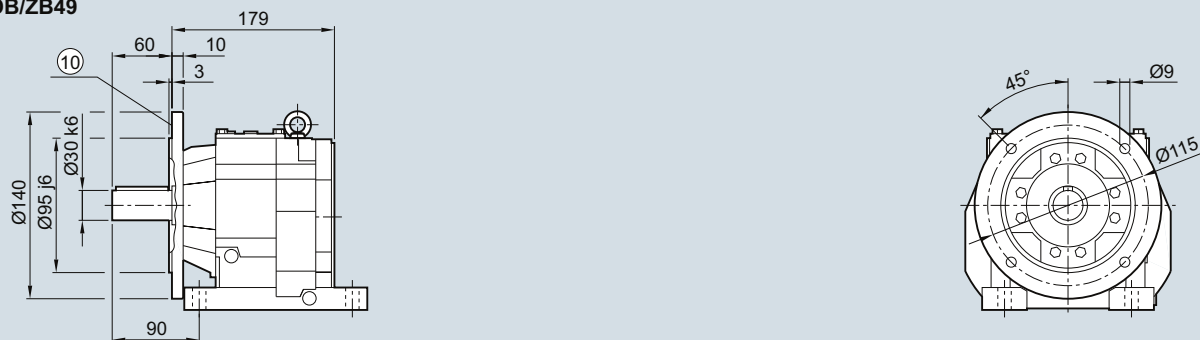

Adapter	a5	b5	c5	f5	e5	s5	z12	d5/D	E	F	GA	k
63	140	95	12	4.5	115	M8	2.5	11	23	4	12.5	247.0
71	160	110	12	4.5	130	M8	2.5	14	30	5	16.0	247.0
80	200	130	15	4.5	165	M10	4.0	19	40	6	21.5	275.0
90	200	130	15	4.5	165	M10	4.0	24	50	8	27.0	275.0
100	250	180	14	5.0	215	M12x21	7.5	28	60	8	31.0	329.5
112	250	180	14	5.0	215	M12x21	7.5	28	60	8	31.0	329.5
132	300	230	12	6.0	265	M12x20	3.0	38	80	10	41.0	347.0

④ DIN 332

Ⓜ For inner contour, see page 3/111

⑤ Feather key/keyway DIN 6885

DF/ZF49 gearbox in a flange-mounted design

DZF030K4

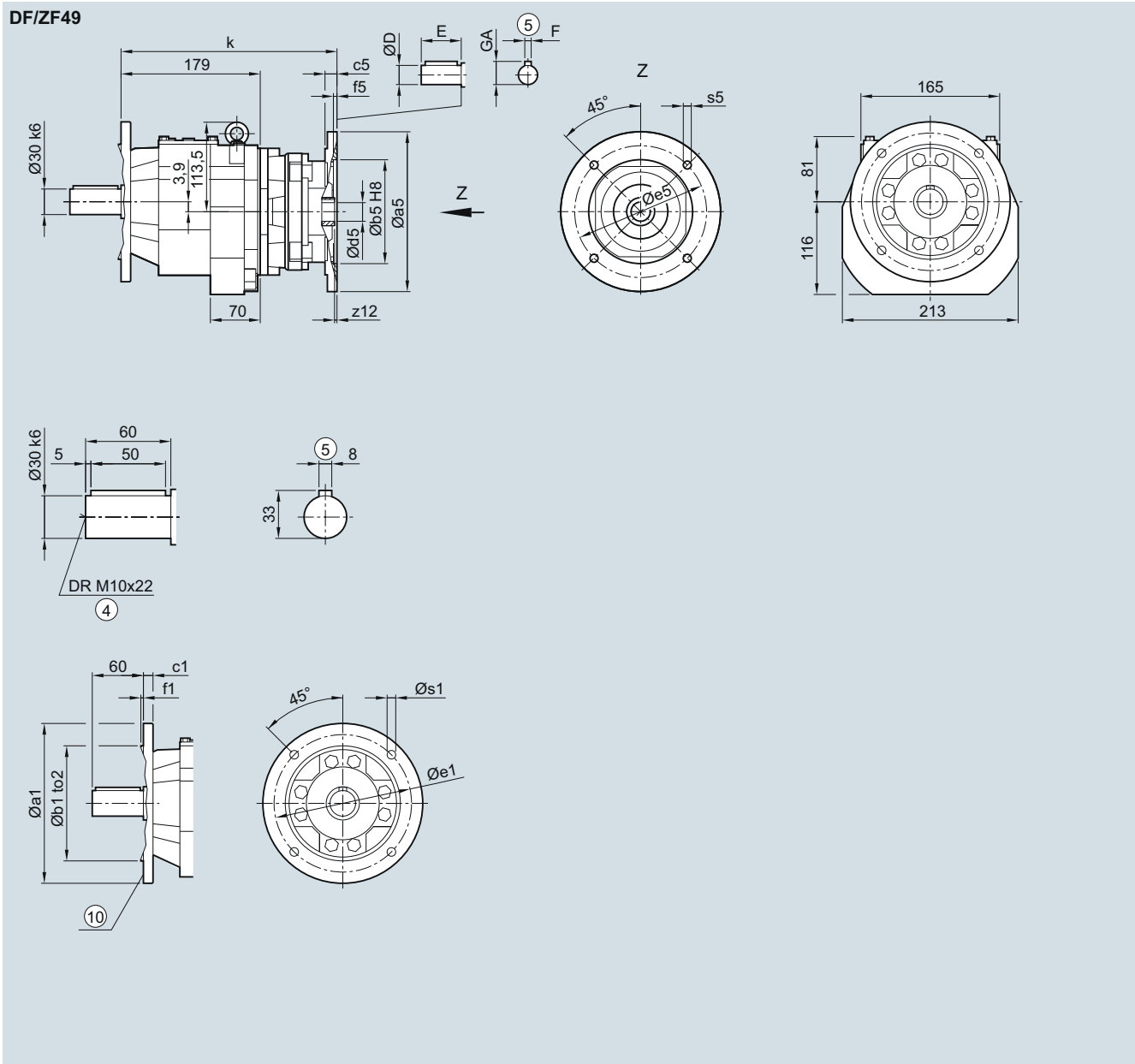

Flange	a1	b1	to2	c1	e1	f1	s1					
	140	95	j6	10	115	3.0	9.0					
	160	110	j6	10	130	3.5	9.0					
	200	130	j6	12	165	3.5	11.0					
Adapter	a5	b5	c5	f5	e5	s5	z12	d5/D	E	F	GA	k
63	140	95	12	4.5	115	M8	2.5	11	23	4	12.5	247.0
71	160	110	12	4.5	130	M8	2.5	14	30	5	16.0	247.0
80	200	130	15	4.5	165	M10	4.0	19	40	6	21.5	275.0
90	200	130	15	4.5	165	M10	4.0	24	50	8	27.0	275.0
100	250	180	14	5.0	215	M12x21	7.5	28	60	8	31.0	329.5
112	250	180	14	5.0	215	M12x21	7.5	28	60	8	31.0	329.5
132	300	230	12	6.0	265	M12x20	3.0	38	80	10	41.0	347.0

④ DIN 332

Ⓜ For inner contour, see page 3/111

⑤ Feather key/keyway DIN 6885

SIMOGEAR Gearboxes

Helical gearbox with adapter K4

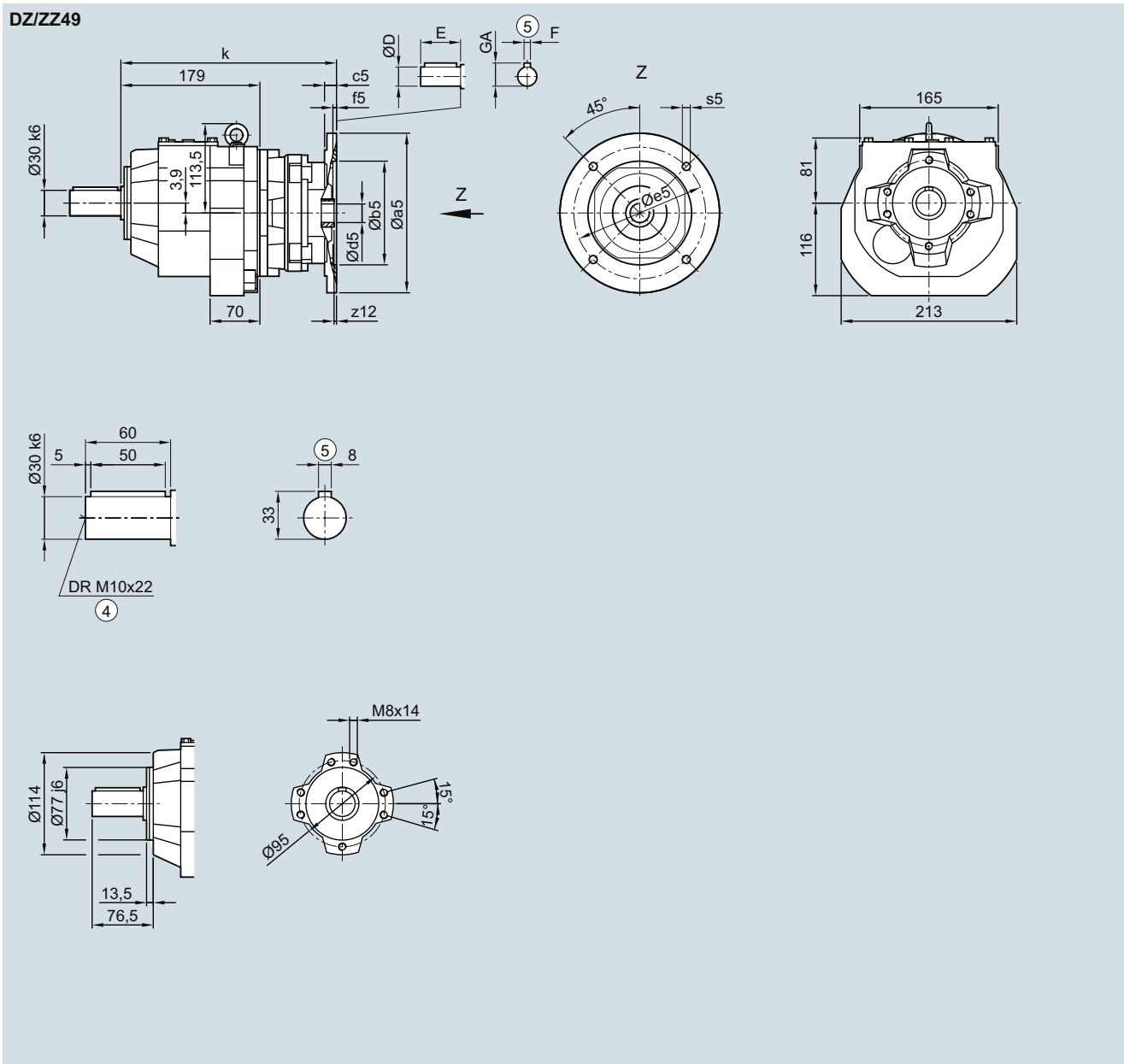
Dimensions**DZ/ZZ49 gearbox in a housing flange design****DZZ030K4**

Adapter	a5	b5	c5	f5	e5	s5	z12	d5/D	E	F	GA	k
63	140	95	12	4.5	115	M8	2.5	11	23	4	12.5	247.0
71	160	110	12	4.5	130	M8	2.5	14	30	5	16.0	247.0
80	200	130	15	4.5	165	M10	4.0	19	40	6	21.5	275.0
90	200	130	15	4.5	165	M10	4.0	24	50	8	27.0	275.0
100	250	180	14	5.0	215	M12x21	7.5	28	60	8	31.0	329.5
112	250	180	14	5.0	215	M12x21	7.5	28	60	8	31.0	329.5
132	300	230	12	6.0	265	M12x20	3.0	38	80	10	41.0	347.0

④ DIN 332

⑤ Feather key/keyway DIN 6885

D/Z59 and DB/ZB59 gearboxes in a foot and foot/flange-mounted design

DZ030K4, DZB030K4

D/Z59

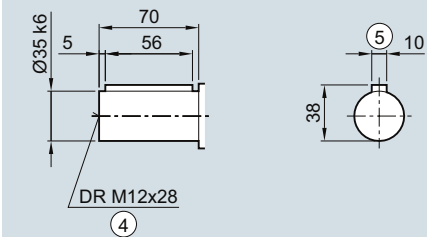
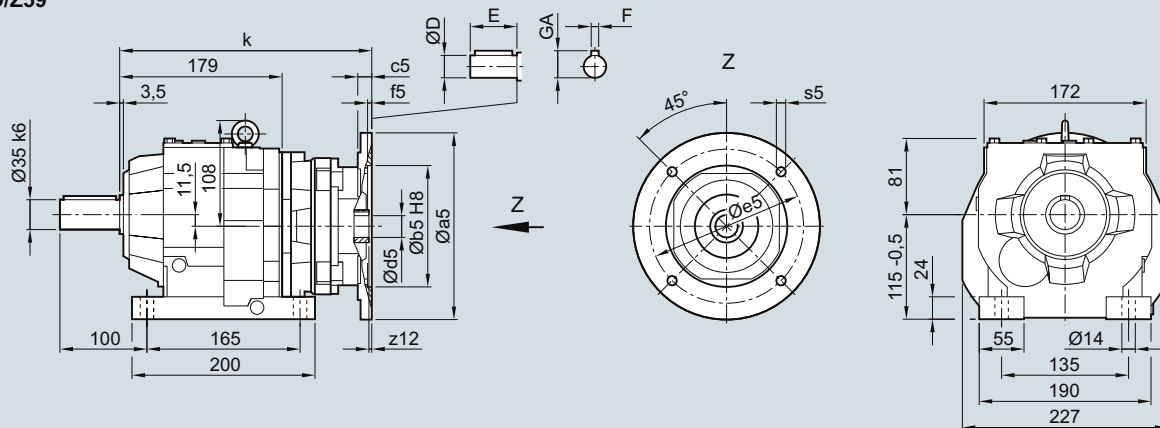

DB/ZB59

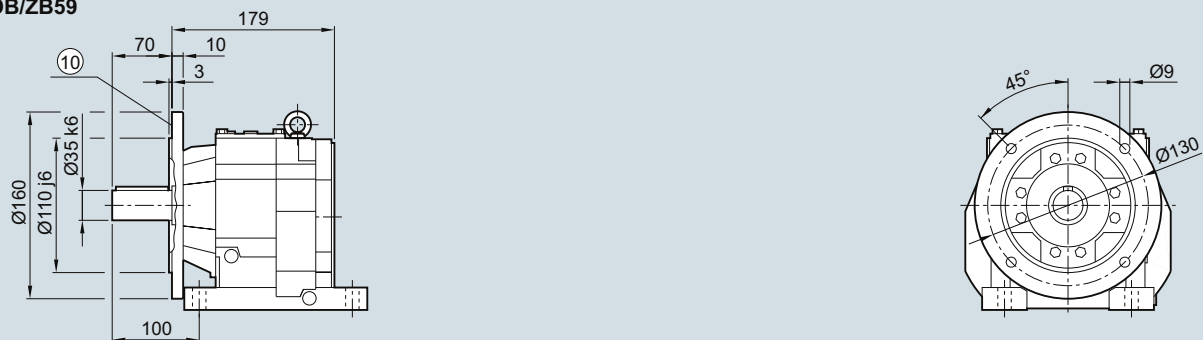

Adapter	a5	b5	c5	f5	e5	s5	z12	d5/D	E	F	GA	k
63	140	95	12	4.5	115	M8	2.5	11	23	4	12.5	247.0
71	160	110	12	4.5	130	M8	2.5	14	30	5	16.0	247.0
80	200	130	15	4.5	165	M10	4.0	19	40	6	21.5	275.0
90	200	130	15	4.5	165	M10	4.0	24	50	8	27.0	275.0
100	250	180	14	5.0	215	M12x21	7.5	28	60	8	31.0	329.5
112	250	180	14	5.0	215	M12x21	7.5	28	60	8	31.0	329.5
132	300	230	12	6.0	265	M12x20	3.0	38	80	10	41.0	347.0

④ DIN 332

Ⓜ For inner contour, see page 3/111

⑤ Feather key/keyway DIN 6885

SIMOGEAR Gearboxes

Helical gearbox with adapter K4

Dimensions

DF/ZF59 gearbox in a flange-mounted design

DZF030K4

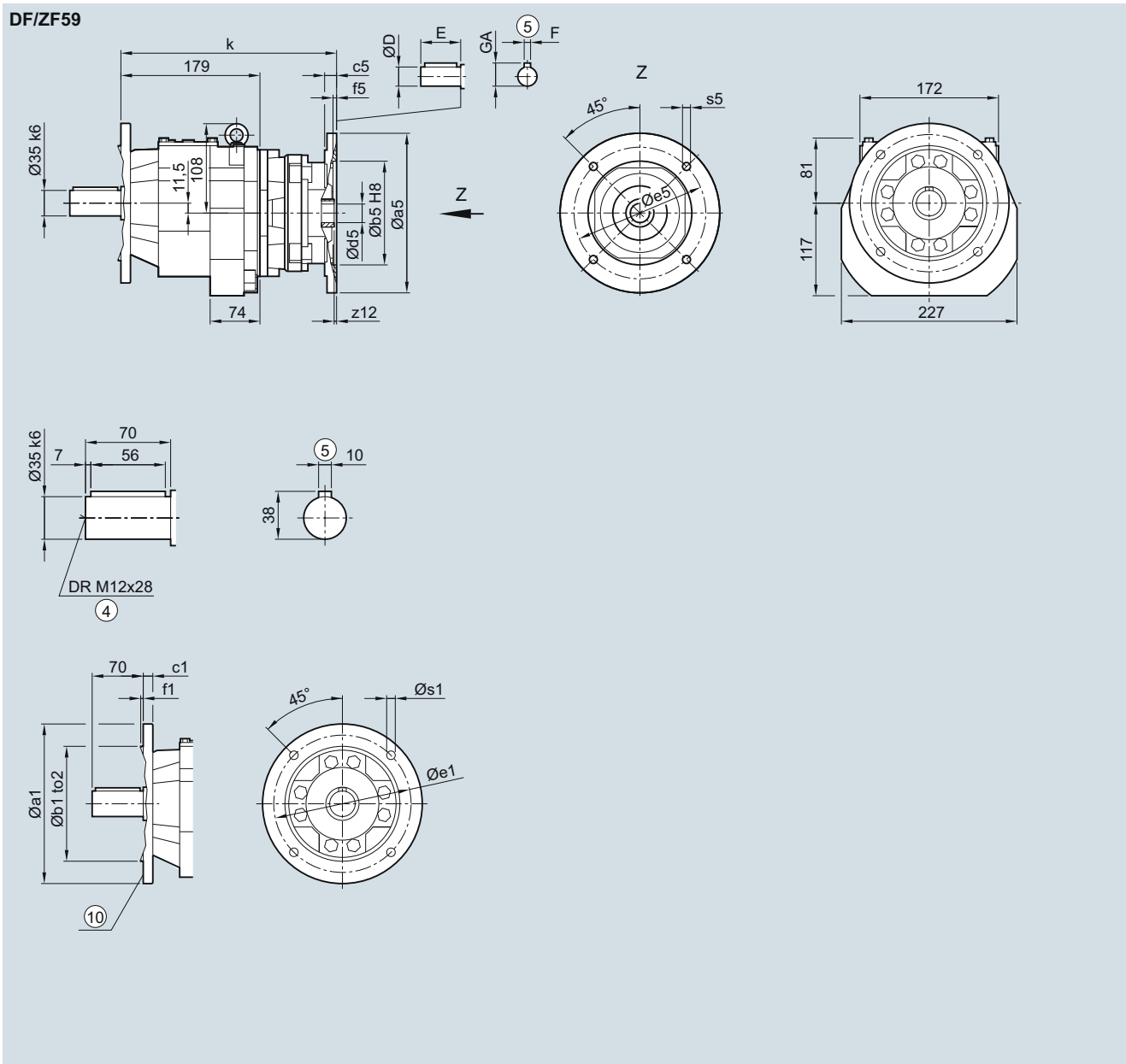

Flange	a1	b1	to2	c1	e1	f1	s1
	160	110	j6	10	130	3.5	9.0
	200	130	j6	12	165	3.5	11.0
	250	180	j6	15	215	4.0	13.5

Adapter	a5	b5	c5	f5	e5	s5	z12	d5/D	E	F	GA	k
63	140	95	12	4.5	115	M8	2.5	11	23	4	12.5	247.0
71	160	110	12	4.5	130	M8	2.5	14	30	5	16.0	247.0
80	200	130	15	4.5	165	M10	4.0	19	40	6	21.5	275.0
90	200	130	15	4.5	165	M10	4.0	24	50	8	27.0	275.0
100	250	180	14	5.0	215	M12x21	7.5	28	60	8	31.0	329.5
112	250	180	14	5.0	215	M12x21	7.5	28	60	8	31.0	329.5
132	300	230	12	6.0	265	M12x20	3.0	38	80	10	41.0	347.0

④ DIN 332

Ⓜ For inner contour, see page 3/111

⑤ Feather key/keyway DIN 6885

DZ/ZZ59 gearbox in a housing flange design

DZZ030K4

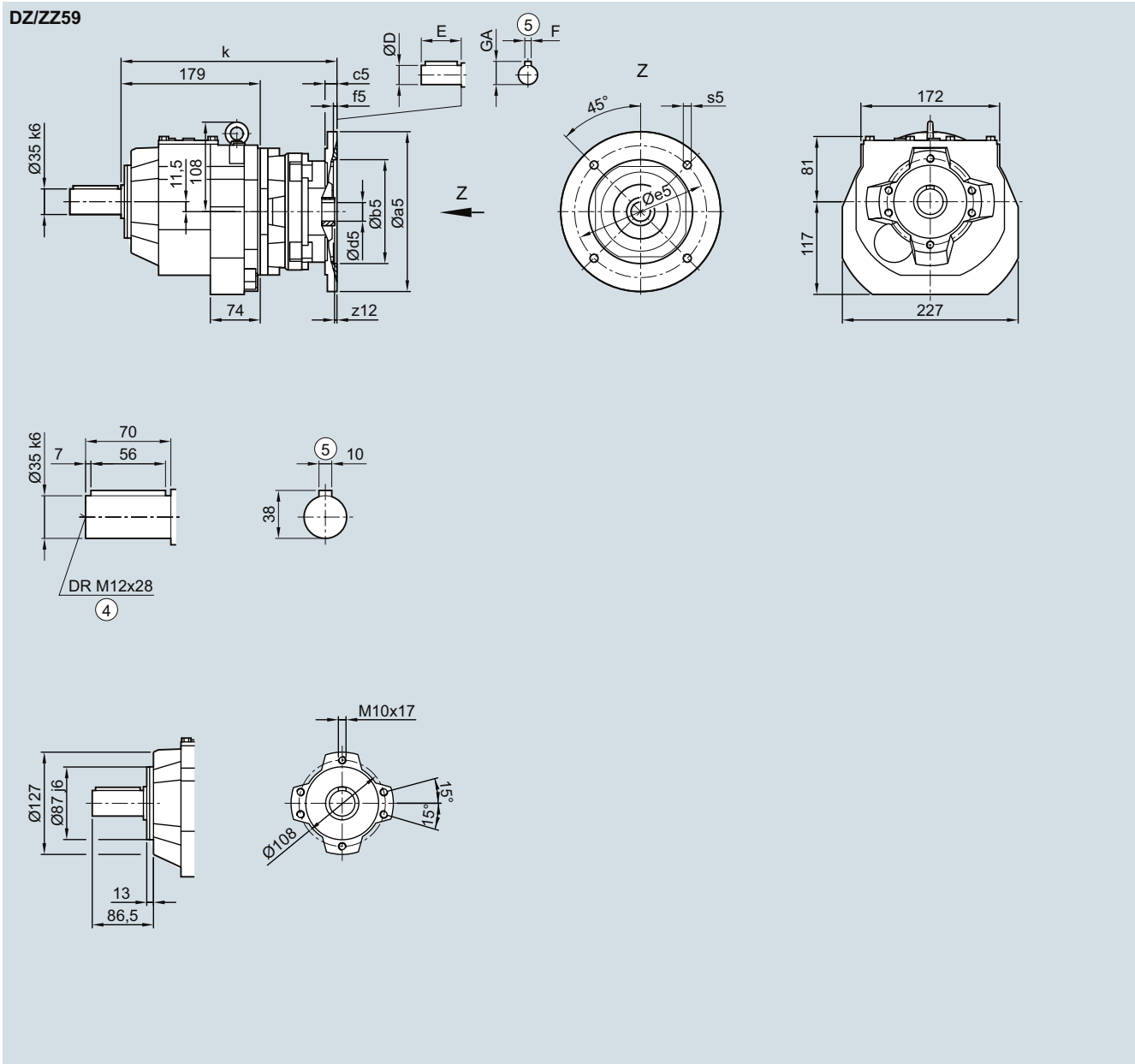

Adapter	a5	b5	c5	f5	e5	s5	z12	d5/D	E	F	GA	k
63	140	95	12	4.5	115	M8	2.5	11	23	4	12.5	247.0
71	160	110	12	4.5	130	M8	2.5	14	30	5	16.0	247.0
80	200	130	15	4.5	165	M10	4.0	19	40	6	21.5	275.0
90	200	130	15	4.5	165	M10	4.0	24	50	8	27.0	275.0
100	250	180	14	5.0	215	M12x21	7.5	28	60	8	31.0	329.5
112	250	180	14	5.0	215	M12x21	7.5	28	60	8	31.0	329.5
132	300	230	12	6.0	265	M12x20	3.0	38	80	10	41.0	347.0

④ DIN 332

⑤ Feather key/keyway DIN 6885

SIMOGEAR Gearboxes

Helical gearbox with adapter K4

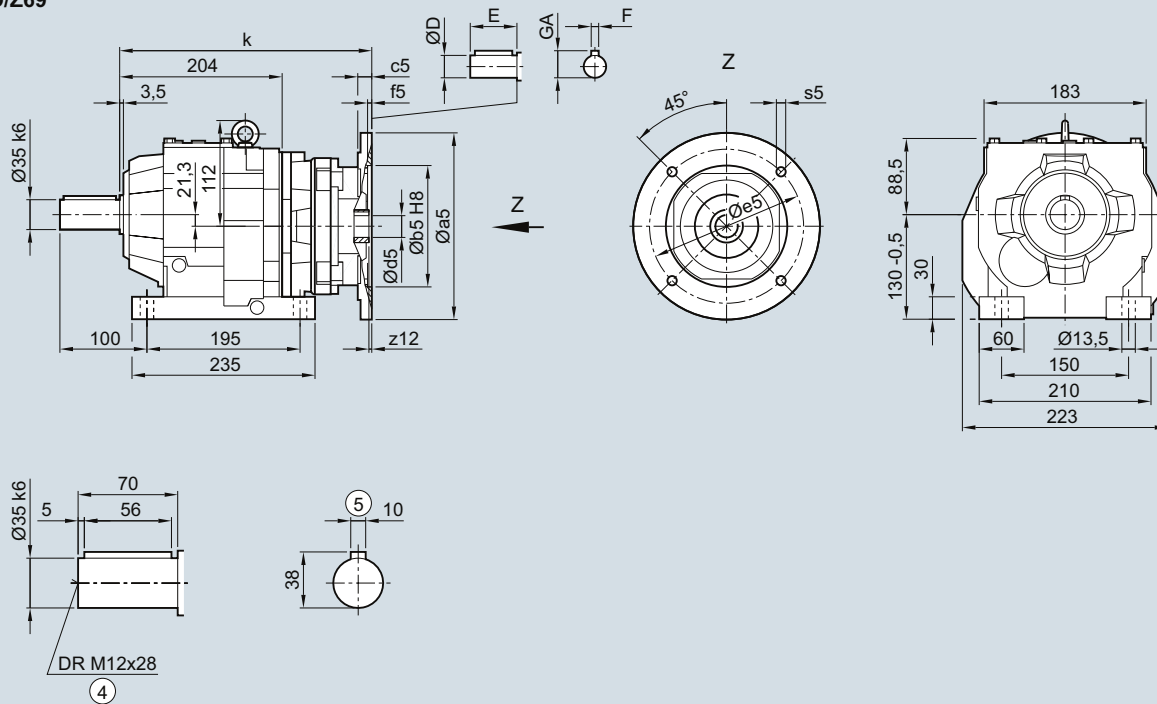
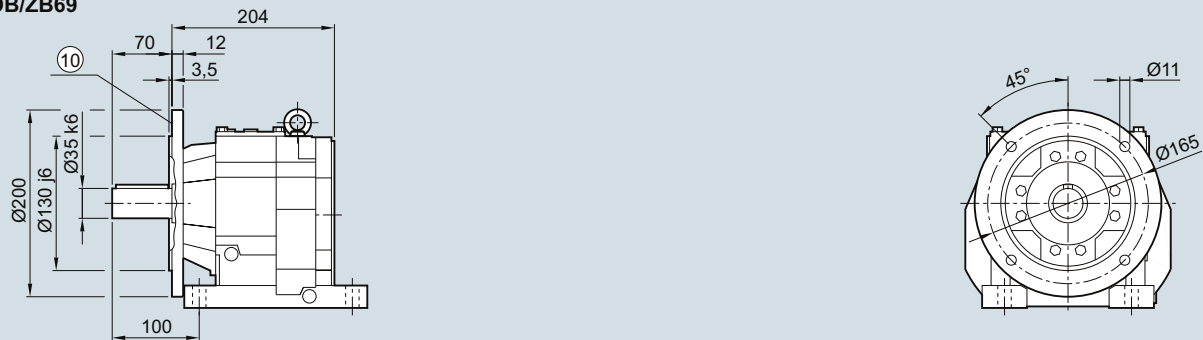
Dimensions**D/Z69 and DB/ZB69 gearboxes in a foot and foot/flange-mounted design****DZ030K4, DZB030K4****D/Z69****DB/ZB69**

Adapter	a5	b5	c5	f5	e5	s5	z12	d5/D	E	F	GA	k
63	140	95	12	4.5	115	M8	2.5	11	23	4	12.5	272.0
71	160	110	12	4.5	130	M8	2.5	14	30	5	16.0	272.0
80	200	130	15	4.5	165	M10	4.0	19	40	6	21.5	300.0
90	200	130	15	4.5	165	M10	4.0	24	50	8	27.0	300.0
100	250	180	14	5.0	215	M12x21	7.5	28	60	8	31.0	354.5
112	250	180	14	5.0	215	M12x21	7.5	28	60	8	31.0	354.5
132	300	230	12	6.0	265	M12x20	3.0	38	80	10	41.0	372.0

④ DIN 332

Ⓜ For inner contour, see page 3/111

⑤ Feather key/keyway DIN 6885

DF/ZF69 gearbox in a flange-mounted design

DZF030K4

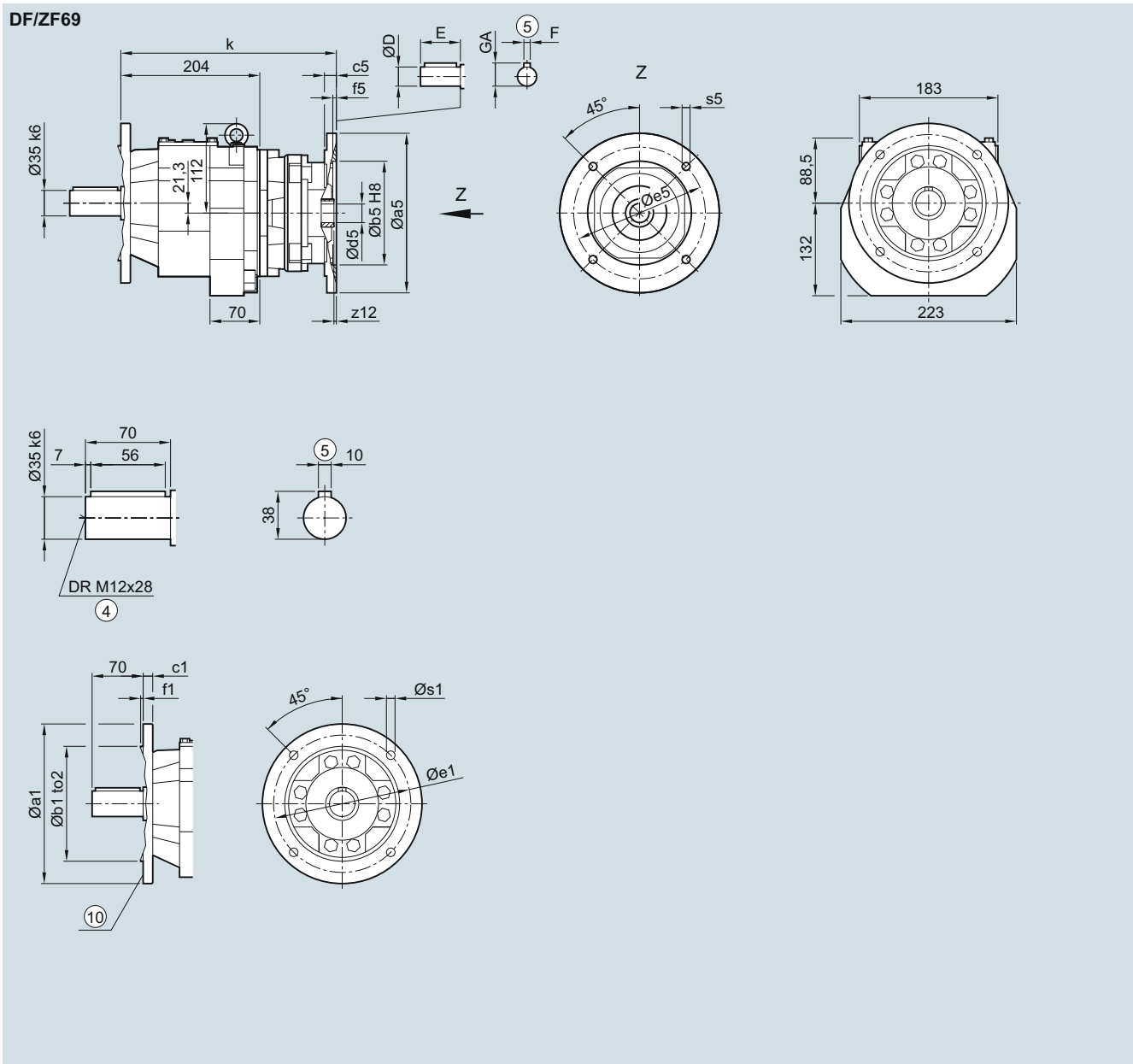

Flange	a1	b1	to2	c1	e1	f1	s1					
	200	130	j6	12	165	3.5	11.0					
	250	180	j6	15	215	4.0	13.5					
Adapter	a5	b5	c5	f5	e5	s5	z12	d5/D	E	F	GA	k
63	140	95	12	4.5	115	M8	2.5	11	23	4	12.5	272.0
71	160	110	12	4.5	130	M8	2.5	14	30	5	16.0	272.0
80	200	130	15	4.5	165	M10	4.0	19	40	6	21.5	300.0
90	200	130	15	4.5	165	M10	4.0	24	50	8	27.0	300.0
100	250	180	14	5.0	215	M12x21	7.5	28	60	8	31.0	354.5
112	250	180	14	5.0	215	M12x21	7.5	28	60	8	31.0	354.5
132	300	230	12	6.0	265	M12x20	3.0	38	80	10	41.0	372.0

④ DIN 332

Ⓜ For inner contour, see page 3/111

⑤ Feather key/keyway DIN 6885

SIMOGEAR Gearboxes

Helical gearbox with adapter K4

Dimensions

DZ/ZZ69 gearbox in a housing flange design

DZZ030K4

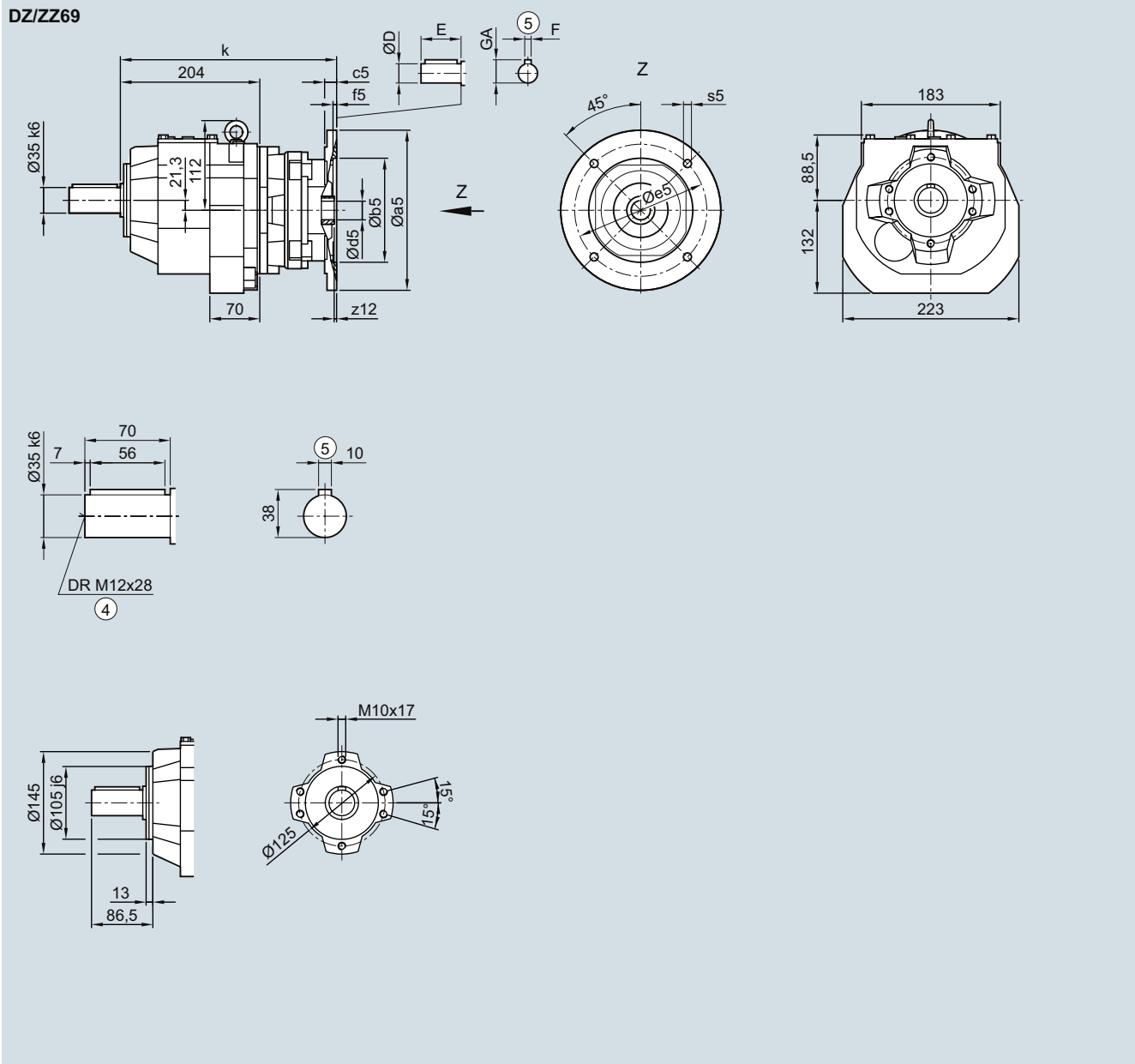

Adapter	a5	b5	c5	f5	e5	s5	z12	d5/D	E	F	GA	k
63	140	95	12	4.5	115	M8	2.5	11	23	4	12.5	272.0
71	160	110	12	4.5	130	M8	2.5	14	30	5	16.0	272.0
80	200	130	15	4.5	165	M10	4.0	19	40	6	21.5	300.0
90	200	130	15	4.5	165	M10	4.0	24	50	8	27.0	300.0
100	250	180	14	5.0	215	M12x21	7.5	28	60	8	31.0	354.5
112	250	180	14	5.0	215	M12x21	7.5	28	60	8	31.0	354.5
132	300	230	12	6.0	265	M12x20	3.0	38	80	10	41.0	372.0

D/Z79 and DB/ZB79 gearboxes in a foot and foot/flange-mounted design

DZ030K4, DZB030K4

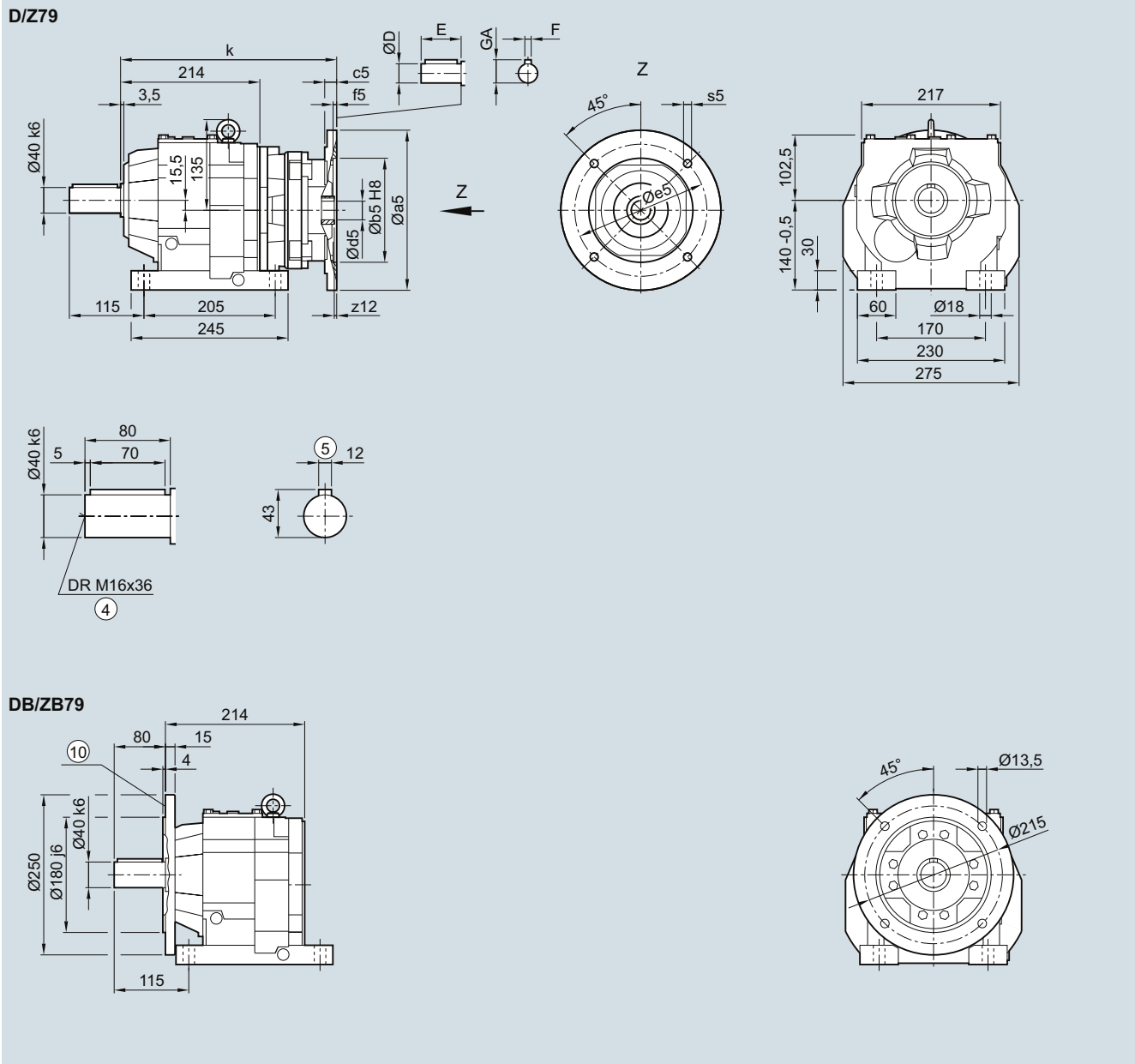

Adapter	a5	b5	c5	f5	e5	s5	z12	d5/D	E	F	GA	k
71	160	110	12	4.5	130	M8	2.5	14	30	5	16.0	280.0
80	200	130	15	4.5	165	M10	4.0	19	40	6	21.5	304.0
90	200	130	15	4.5	165	M10	4.0	24	50	8	27.0	304.0
100	250	180	14	5.0	215	M12x21	7.5	28	60	8	31.0	358.5
112	250	180	14	5.0	215	M12x21	7.5	28	60	8	31.0	358.5
132	300	230	12	6.0	265	M12x20	3.0	38	80	10	41.0	376.0
160	350	250	15	6.0	300	M16x25	3.0	42	110	12	45.0	406.0

④ DIN 332

Ⓜ For inner contour, see page 3/111

⑤ Feather key/keyway DIN 6885

SIMOGEAR Gearboxes

Helical gearbox with adapter K4

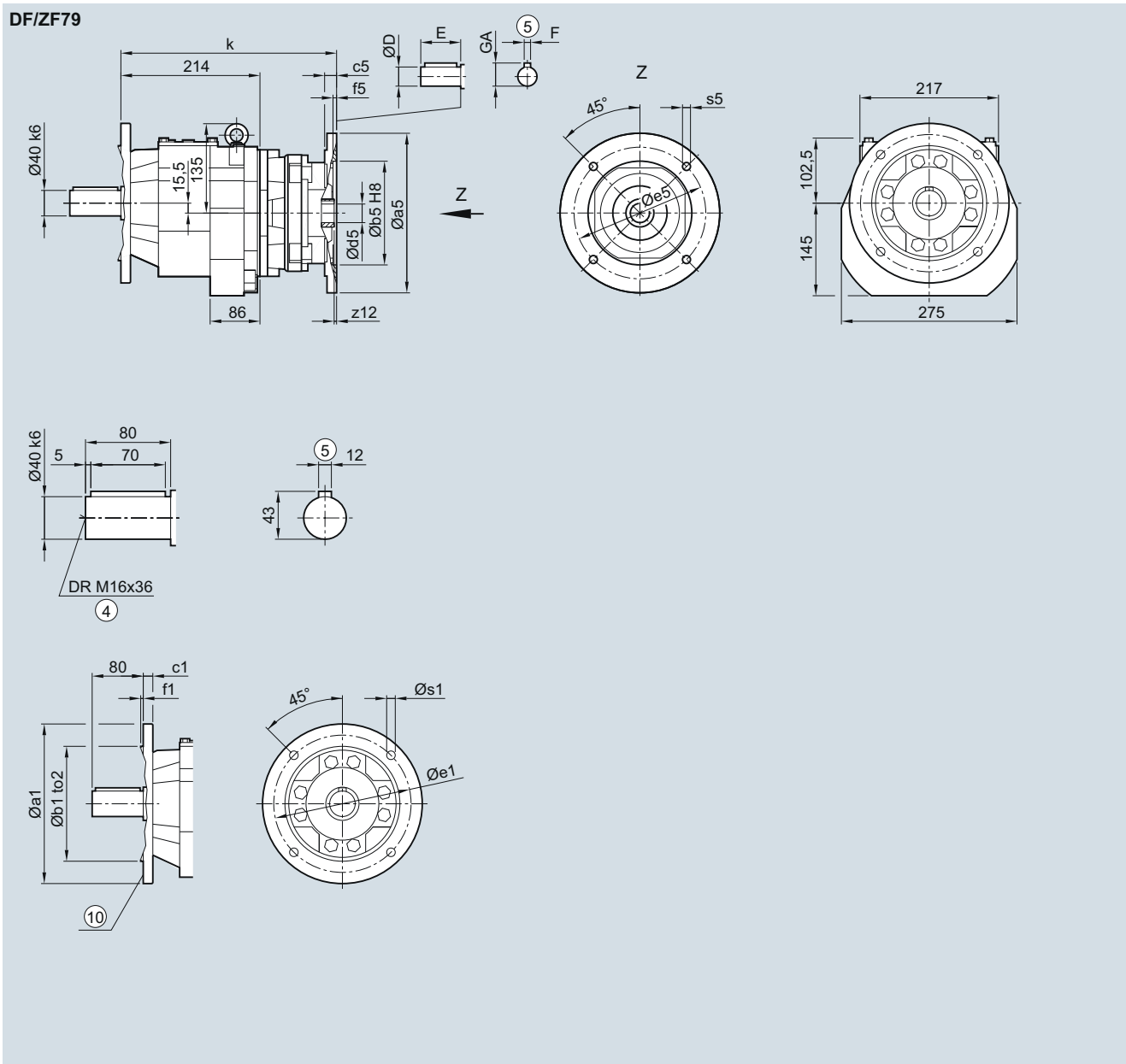
Dimensions**DF/ZF79 gearbox in a flange-mounted design****DZF030K4**

Flange	a1	b1	to2	c1	e1	f1	s1
	250	180	j6	15	215	4.0	13.5
	300	230	j6	16	265	4.0	13.5

Adapter	a5	b5	c5	f5	e5	s5	z12	d5/D	E	F	GA	k
71	160	110	12	4.5	130	M8	2.5	14	30	5	16.0	280.0
80	200	130	15	4.5	165	M10	4.0	19	40	6	21.5	304.0
90	200	130	15	4.5	165	M10	4.0	24	50	8	27.0	304.0
100	250	180	14	5.0	215	M12x21	7.5	28	60	8	31.0	358.5
112	250	180	14	5.0	215	M12x21	7.5	28	60	8	31.0	358.5
132	300	230	12	6.0	265	M12x20	3.0	38	80	10	41.0	376.0
160	350	250	15	6.0	300	M16x25	3.0	42	110	12	45.0	406.0

④ DIN 332

Ⓜ For inner contour, see page 3/111

⑤ Feather key/keyway DIN 6885

DZ/ZZ79 gearbox in a housing flange design

DZZ030K4

DZ/ZZ79

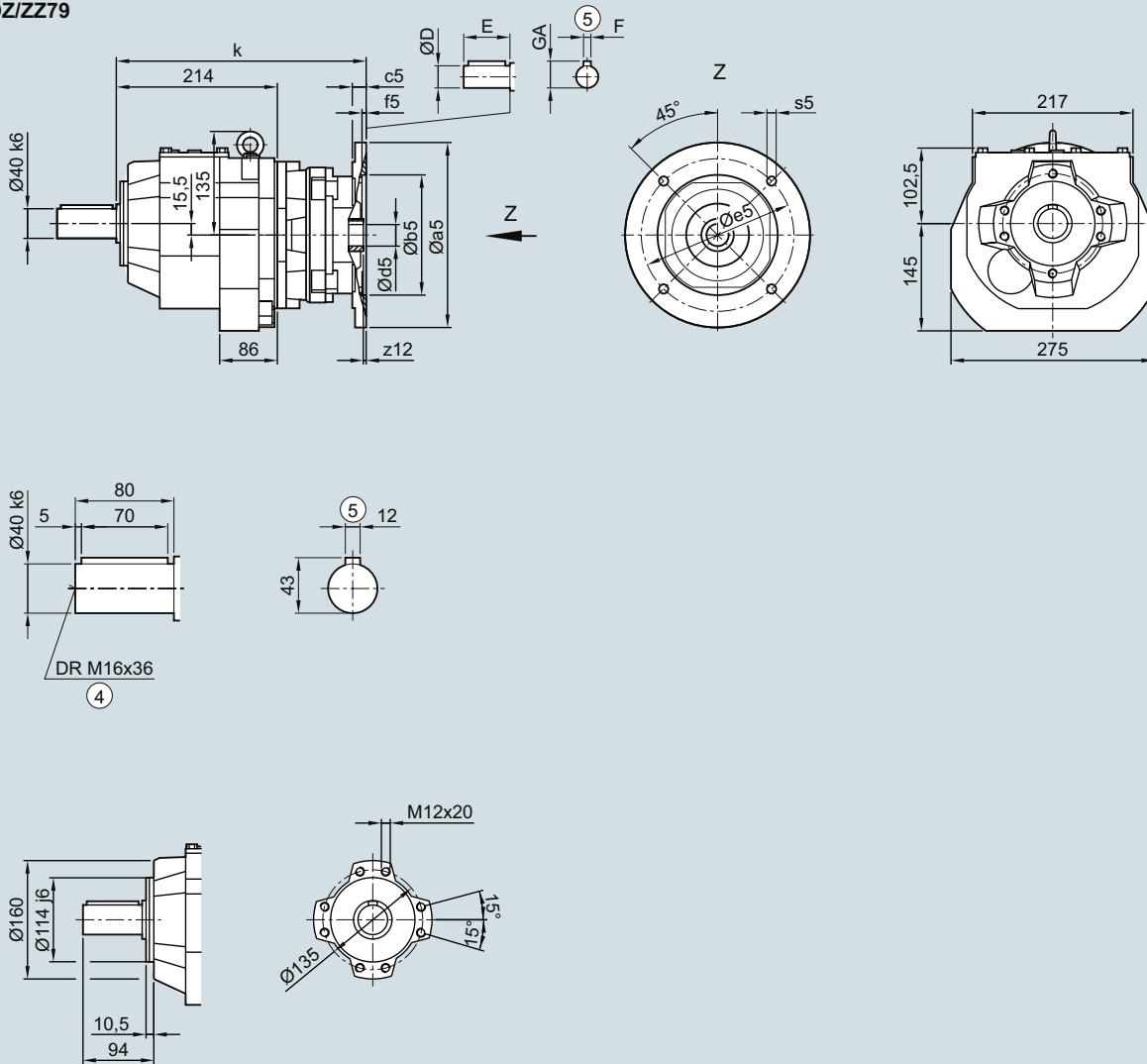

Adapter	a5	b5	c5	f5	e5	s5	z12	d5/D	E	F	GA	k
71	160	110	12	4.5	130	M8	2.5	14	30	5	16.0	280.0
80	200	130	15	4.5	165	M10	4.0	19	40	6	21.5	304.0
90	200	130	15	4.5	165	M10	4.0	24	50	8	27.0	304.0
100	250	180	14	5.0	215	M12x21	7.5	28	60	8	31.0	358.5
112	250	180	14	5.0	215	M12x21	7.5	28	60	8	31.0	358.5
132	300	230	12	6.0	265	M12x20	3.0	38	80	10	41.0	376.0
160	350	250	15	6.0	300	M16x25	3.0	42	110	12	45.0	406.0

④ DIN 332

⑤ Feather key/keyway DIN 6885

SIMOGEAR Gearboxes

Helical gearbox with adapter K4

Dimensions

D/Z89 and DB/ZB89 gearboxes in a foot and foot/flange-mounted design

DZ030K4, DZB030K4

D/Z89

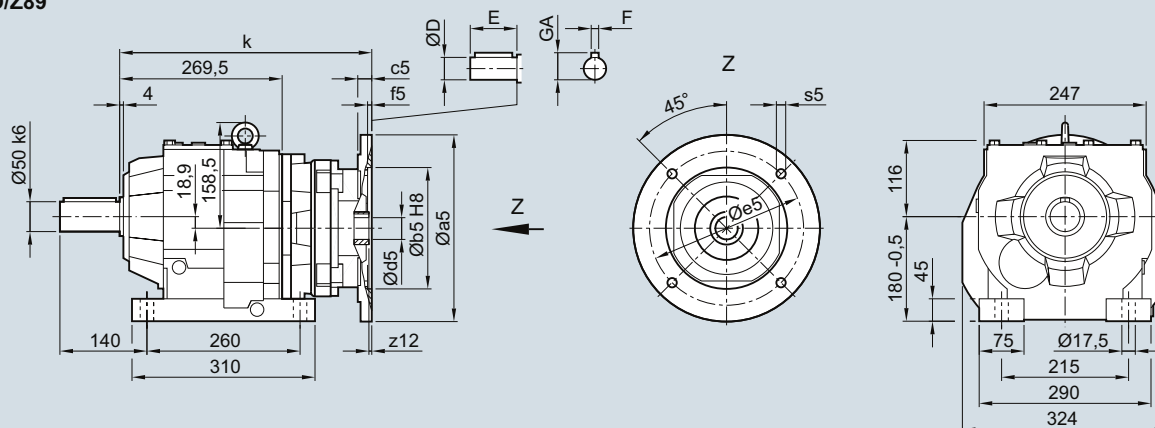

DB/ZB89

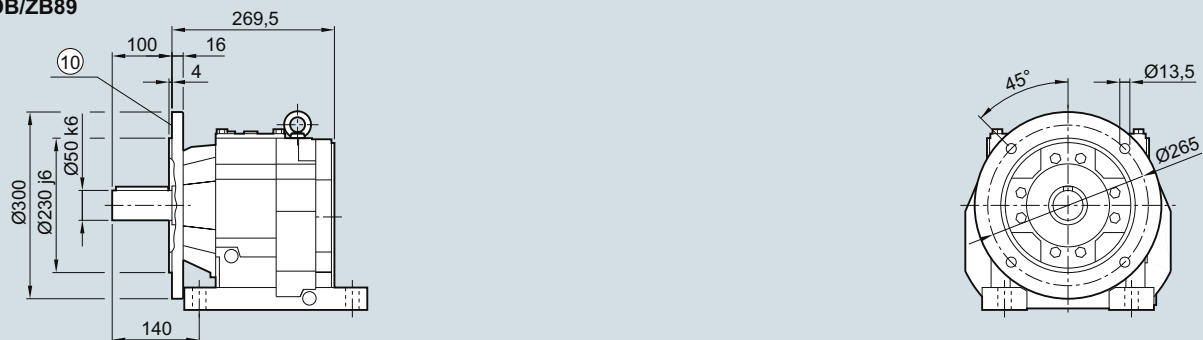

Adapter	a5	b5	c5	f5	e5	s5	z12	d5/D	E	F	GA	k
80	200	130	15	4.5	165	M10	4.0	19	40	6	21.5	346.5
90	200	130	15	4.5	165	M10	4.0	24	50	8	27.0	346.5
100	250	180	14	5.0	215	M12x21	7.5	28	60	8	31.0	397.0
112	250	180	14	5.0	215	M12x21	7.5	28	60	8	31.0	397.0
132	300	230	12	6.0	265	M12x20	3.0	38	80	10	41.0	414.5
160	350	250	15	6.0	300	M16x25	3.0	42	110	12	45.0	444.5
180	350	250	15	6.0	300	M16x25	3.0	48	110	14	51.5	444.5

④ DIN 332

Ⓜ For inner contour, see page 3/111

⑤ Feather key/keyway DIN 6885

DF/ZF89 gearbox in a flange-mounted design

DZF030K4

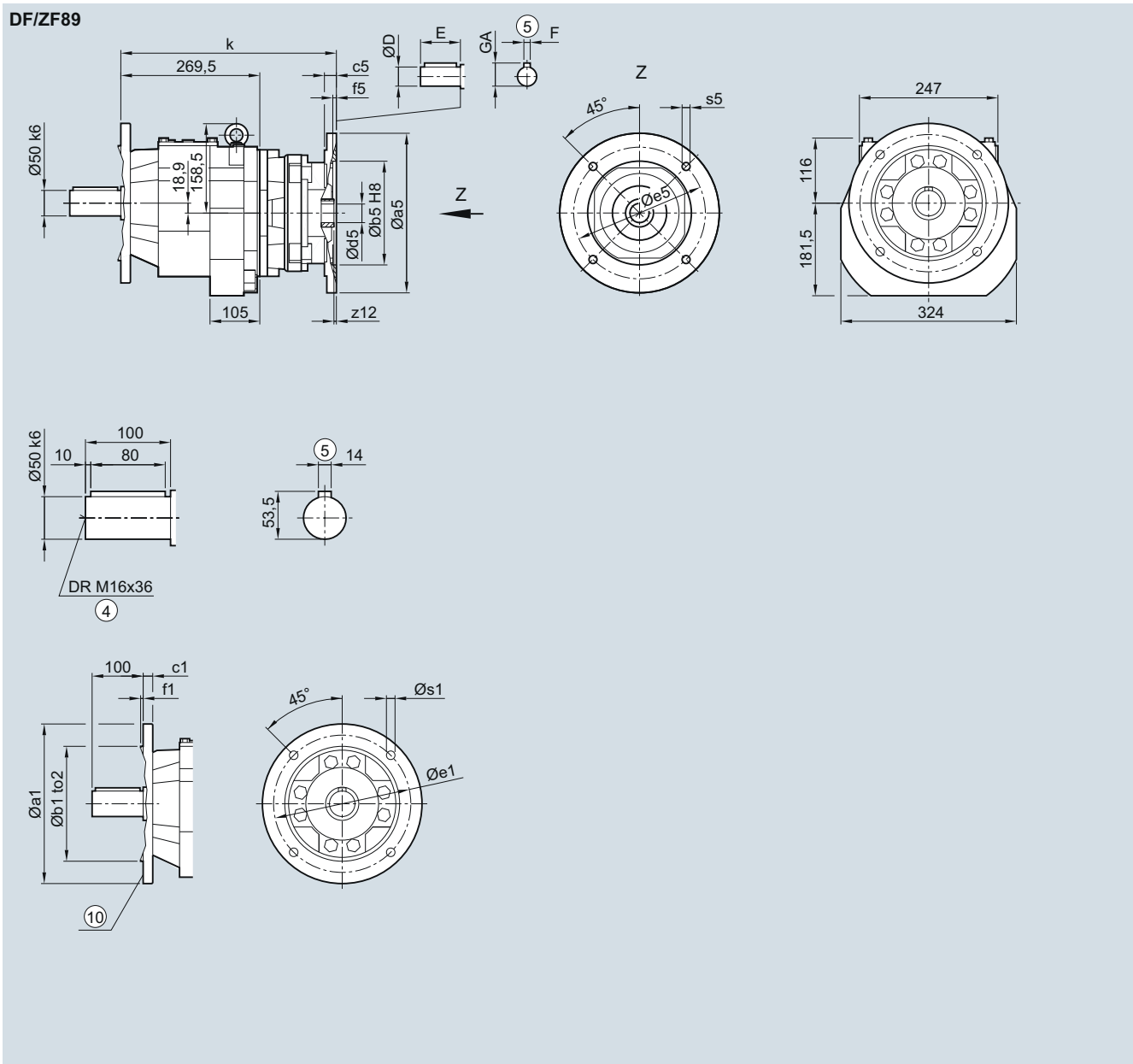

Flange	a1	b1	to2	c1	e1	f1	s1					
	300	230	j6	16	265	4.0	13.5					
	350	250	j6	18	300	5.0	17.5					
Adapter	a5	b5	c5	f5	e5	s5	z12	d5/D	E	F	GA	k
80	200	130	15	4.5	165	M10	4.0	19	40	6	21.5	346.5
90	200	130	15	4.5	165	M10	4.0	24	50	8	27.0	346.5
100	250	180	14	5.0	215	M12x21	7.5	28	60	8	31.0	397.0
112	250	180	14	5.0	215	M12x21	7.5	28	60	8	31.0	397.0
132	300	230	12	6.0	265	M12x20	3.0	38	80	10	41.0	414.5
160	350	250	15	6.0	300	M16x25	3.0	42	110	12	45.0	444.5
180	350	250	15	6.0	300	M16x25	3.0	48	110	14	51.5	444.5

④ DIN 332

Ⓜ For inner contour, see page 3/111

⑤ Feather key/keyway DIN 6885

SIMOGEAR Gearboxes

Helical gearbox with adapter K4

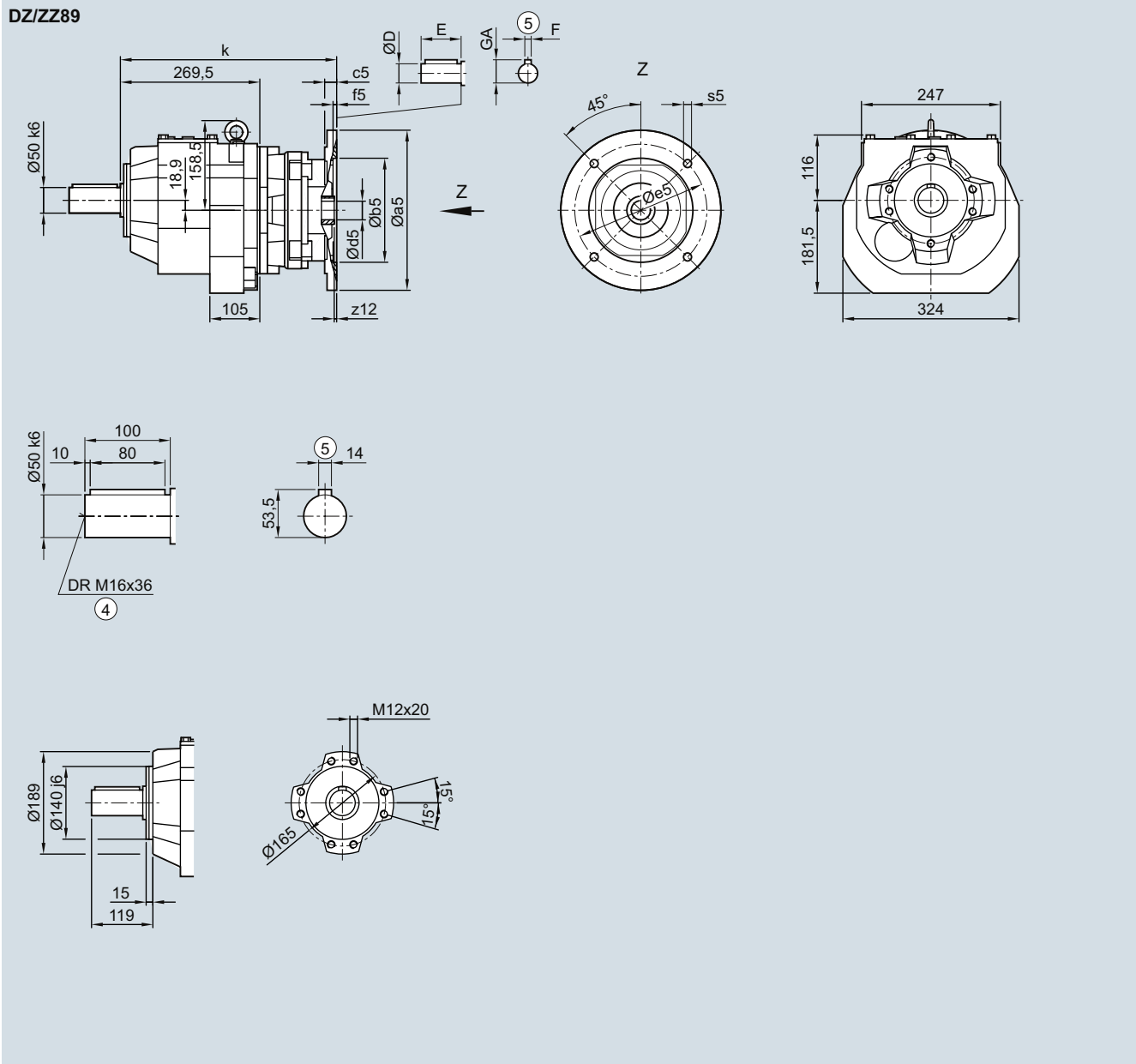
Dimensions**DZ/ZZ89 gearbox in a housing flange design****DZZ030K4**

Adapter	a5	b5	c5	f5	e5	s5	z12	d5/D	E	F	GA	k
80	200	130	15	4.5	165	M10	4.0	19	40	6	21.5	346.5
90	200	130	15	4.5	165	M10	4.0	24	50	8	27.0	346.5
100	250	180	14	5.0	215	M12x21	7.5	28	60	8	31.0	397.0
112	250	180	14	5.0	215	M12x21	7.5	28	60	8	31.0	397.0
132	300	230	12	6.0	265	M12x20	3.0	38	80	10	41.0	414.5
160	350	250	15	6.0	300	M16x25	3.0	42	110	12	45.0	444.5
180	350	250	15	6.0	300	M16x25	3.0	48	110	14	51.5	444.5

D/Z109 gearbox in a foot-mounted design

DZ030K4

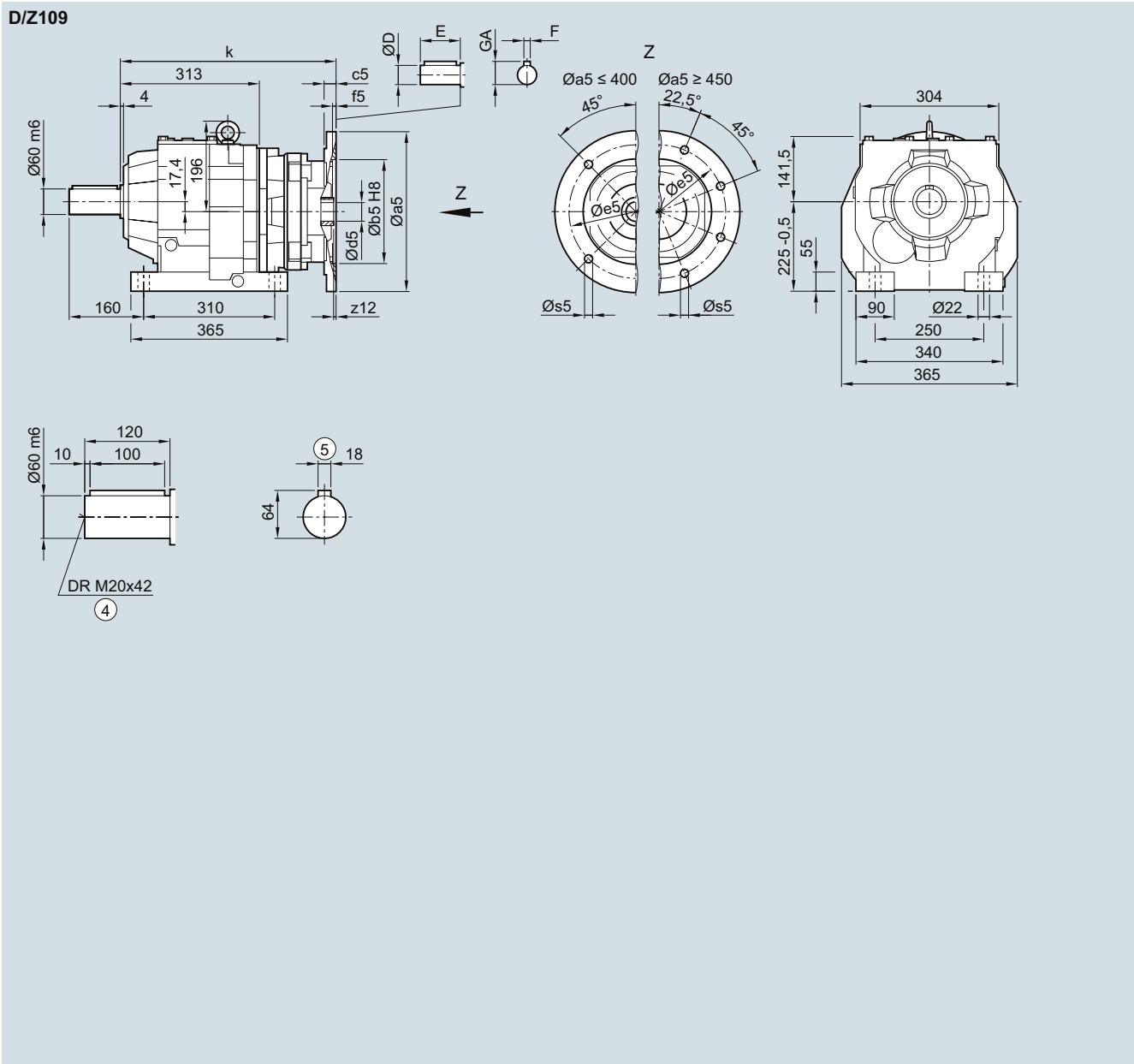

Adapter	a5	b5	c5	f5	e5	s5	z12	d5/D	E	F	GA	k
90	200	130	15	4.5	165	M10	4.0	24	50	8	27.0	383.0
100	250	180	14	5.0	215	M12x21	7.5	28	60	8	31.0	431.5
112	250	180	14	5.0	215	M12x21	7.5	28	60	8	31.0	431.5
132	300	230	12	5.0	265	M12x20	3.0	38	80	10	41.0	449.0
160	350	250	15	6.0	300	M16x25	3.0	42	110	12	45.0	479.0
180	350	250	15	6.0	300	M16x25	3.0	48	110	14	51.5	479.0
200	400	300	20	6.0	350	M16x29	7.0	55	110	16	59.0	519.5
225	450	350	20	6.0	400	M16x29	7.0	60	140	18	64.0	526.0

④ DIN 332

⑤ Feather key/keyway DIN 6885

SIMOGEAR Gearboxes

Helical gearbox with adapter K4

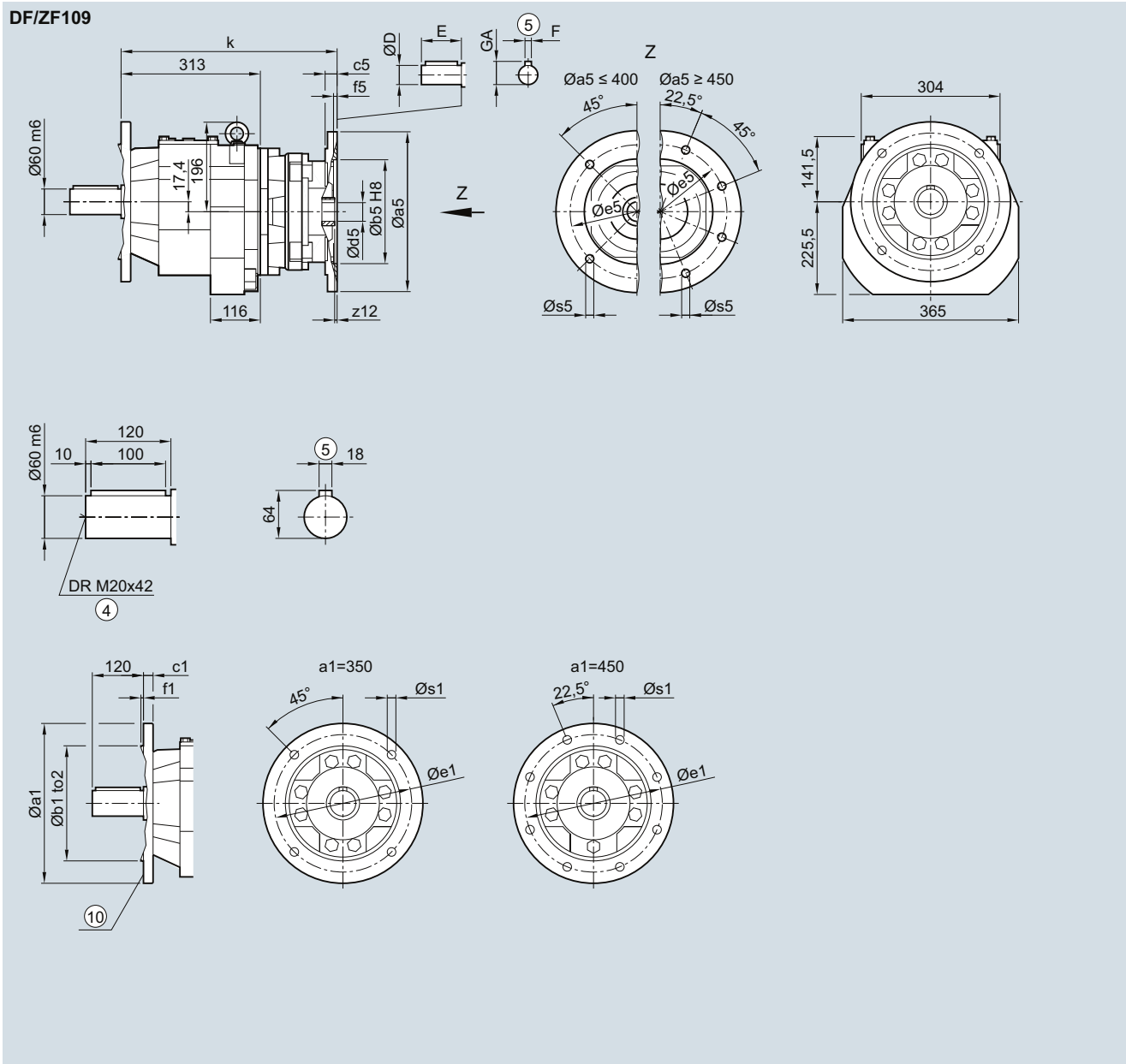
Dimensions**DF/ZF109 gearbox in a flange-mounted design****DZF030K4**

Flange	a1	b1	to2	c1	e1	f1	s1					
	350	250	h6	18	300	5	17.5					
	450	350	h6	22	400	5	17.5					
Adapter	a5	b5	c5	f5	e5	s5	z12	d5/D	E	F	GA	k
90	200	130	15	4.5	165	M10	4.0	24	50	8	27.0	383.0
100	250	180	14	5.0	215	M12x21	7.5	28	60	8	31.0	431.5
112	250	180	14	5.0	215	M12x21	7.5	28	60	8	31.0	431.5
132	300	230	12	5.0	265	M12x20	3.0	38	80	10	41.0	449.0
160	350	250	15	6.0	300	M16x25	3.0	42	110	12	45.0	479.0
180	350	250	15	6.0	300	M16x25	3.0	48	110	14	51.5	479.0
200	400	300	20	6.0	350	M16x29	7.0	55	110	16	59.0	519.5
225	450	350	20	6.0	400	M16x29	7.0	60	140	18	64.0	526.0

④ DIN 332

Ⓜ For inner contour, see page 3/111

⑤ Feather key/keyway DIN 6885

DZ/ZZ109 gearbox in a housing flange design

DZZ030K4

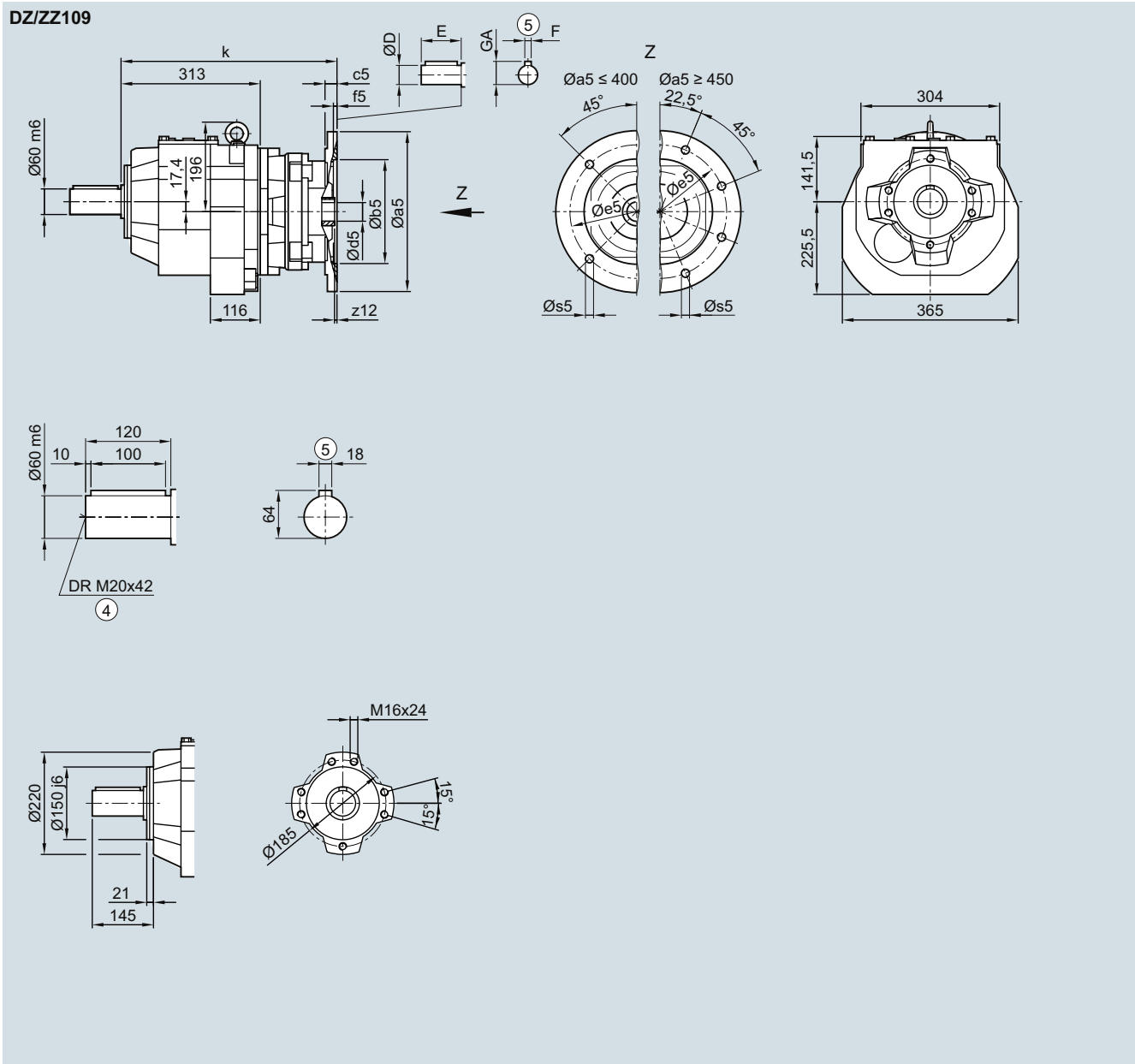

Adapter	a5	b5	c5	f5	e5	s5	z12	d5/D	E	F	GA	k
90	200	130	15	4.5	165	M10	4.0	24	50	8	27.0	383.0
100	250	180	14	5.0	215	M12x21	7.5	28	60	8	31.0	431.5
112	250	180	14	5.0	215	M12x21	7.5	28	60	8	31.0	431.5
132	300	230	12	5.0	265	M12x20	3.0	38	80	10	41.0	449.0
160	350	250	15	6.0	300	M16x25	3.0	42	110	12	45.0	479.0
180	350	250	15	6.0	300	M16x25	3.0	48	110	14	51.5	479.0
200	400	300	20	6.0	350	M16x29	7.0	55	110	16	59.0	519.5
225	450	350	20	6.0	400	M16x29	7.0	60	140	18	64.0	526.0

④ DIN 332

⑤ Feather key/keyway DIN 6885

SIMOGEAR Gearboxes

Helical gearbox with adapter K4

Dimensions

D/Z129 gearbox in a foot-mounted design

DZ030K4

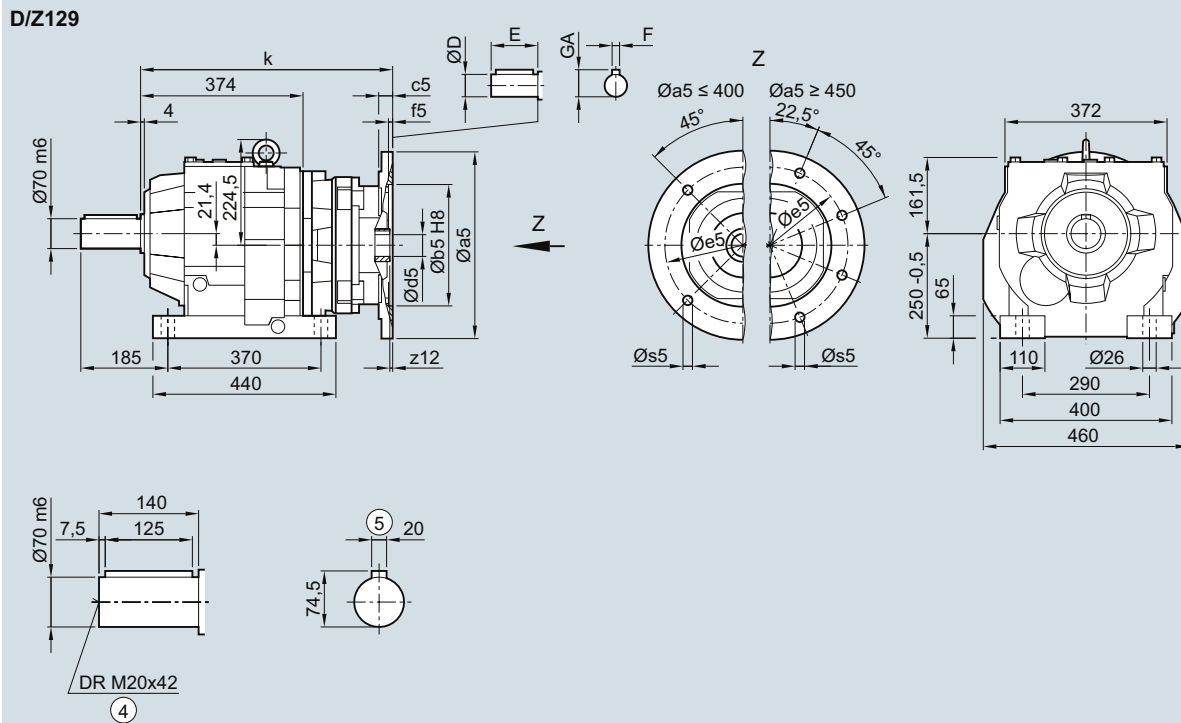

Adapter	a5	b5	c5	f5	e5	s5	z12	d5/D	E	F	GA	k
90	200	130	15	4.5	165	M10	4.0	24	50	8	27.0	437
100	250	180	14	5.0	215	M12x21	7.5	28	60	8	31.0	483.5
112	250	180	14	5.0	215	M12x21	7.5	28	60	8	31.0	483.5
132	300	230	12	5.0	265	M12x20	3.0	38	80	10	41.0	499
160	350	250	15	6.0	300	M16x25	3.0	42	110	12	45.0	529
180	350	250	15	6.0	300	M16x25	3.0	48	110	14	51.5	529
200	400	300	20	6.0	350	M16x29	7.0	55	110	16	59.0	569.5
225	450	350	20	6.0	400	M16x29	7.0	60	140	18	64.0	582
250	550	450	20	6.0	500	M16x29	10.0	65	140	18	69.0	610.5

④ DIN 332

⑤ Feather key/keyway DIN 6885

DF/ZF129 gearbox in a flange-mounted design

DZF030K4

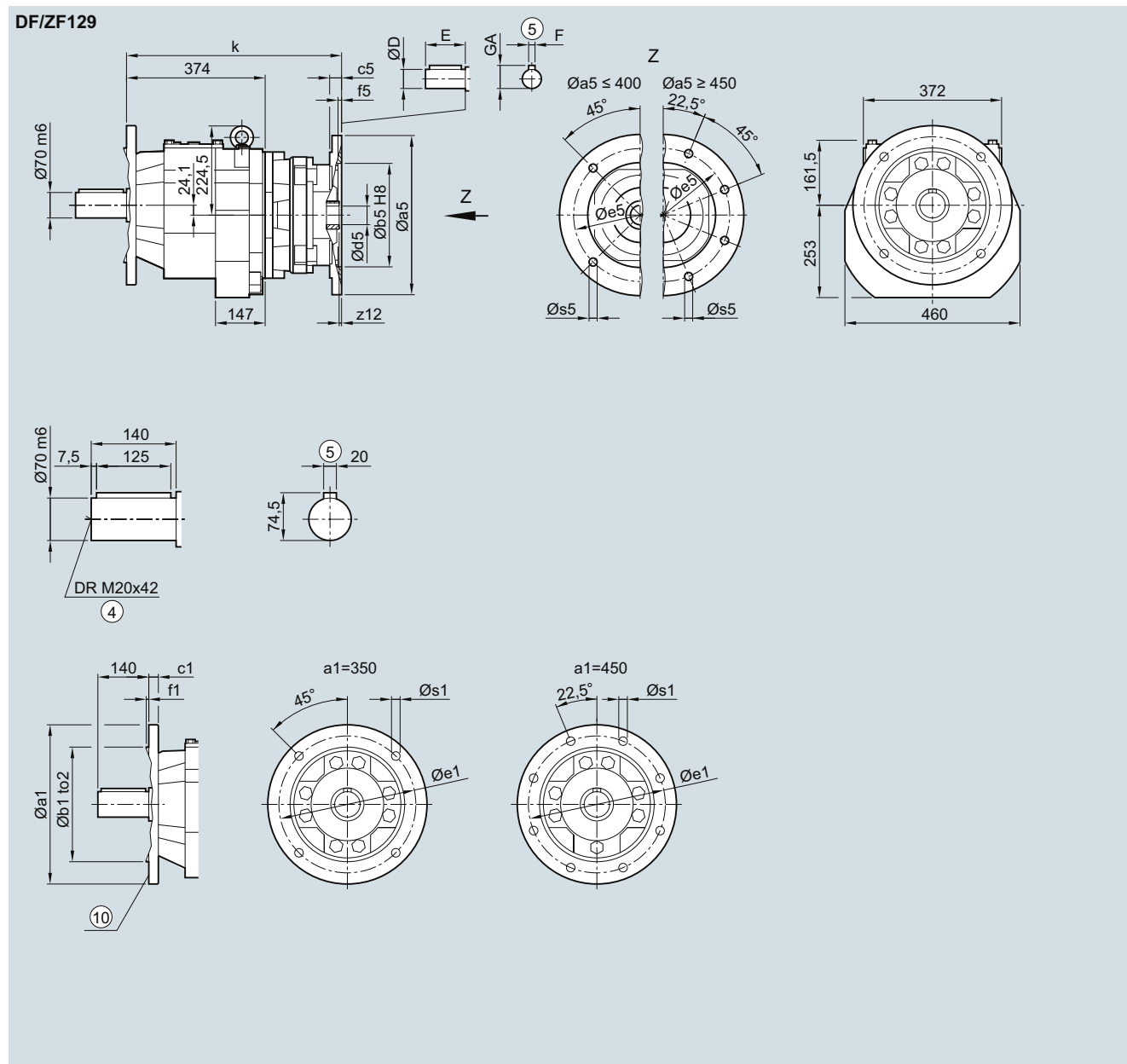

Flange	a1	b1	to2	c1	e1	f1	s1
	350	250	h6	20	300	5	17.5
	450	350	h6	22	400	5	17.5

Adapter	a5	b5	c5	f5	e5	s5	z12	d5/D	E	F	GA	k
90	200	130	15	4.5	165	M10	4.0	24	50	8	27.0	437
100	250	180	14	5.0	215	M12x21	7.5	28	60	8	31.0	483.5
112	250	180	14	5.0	215	M12x21	7.5	28	60	8	31.0	483.5
132	300	230	12	5.0	265	M12x20	3.0	38	80	10	41.0	499
160	350	250	15	6.0	300	M16x25	3.0	42	110	12	45.0	529
180	350	250	15	6.0	300	M16x25	3.0	48	110	14	51.5	529
200	400	300	20	6.0	350	M16x29	7.0	55	110	16	59.0	569.5
225	450	350	20	6.0	400	M16x29	7.0	60	140	18	64.0	582
250	550	450	20	6.0	500	M16x29	10.0	65	140	18	69.0	610.5

④ DIN 332

⑩ For inner contour, see page 3/111

⑤ Feather key/keyway DIN 6885

SIMOGEAR Gearboxes

Helical gearbox with adapter K4

Dimensions

DZ/ZZ129 gearbox in a housing flange design

DZZ030K4

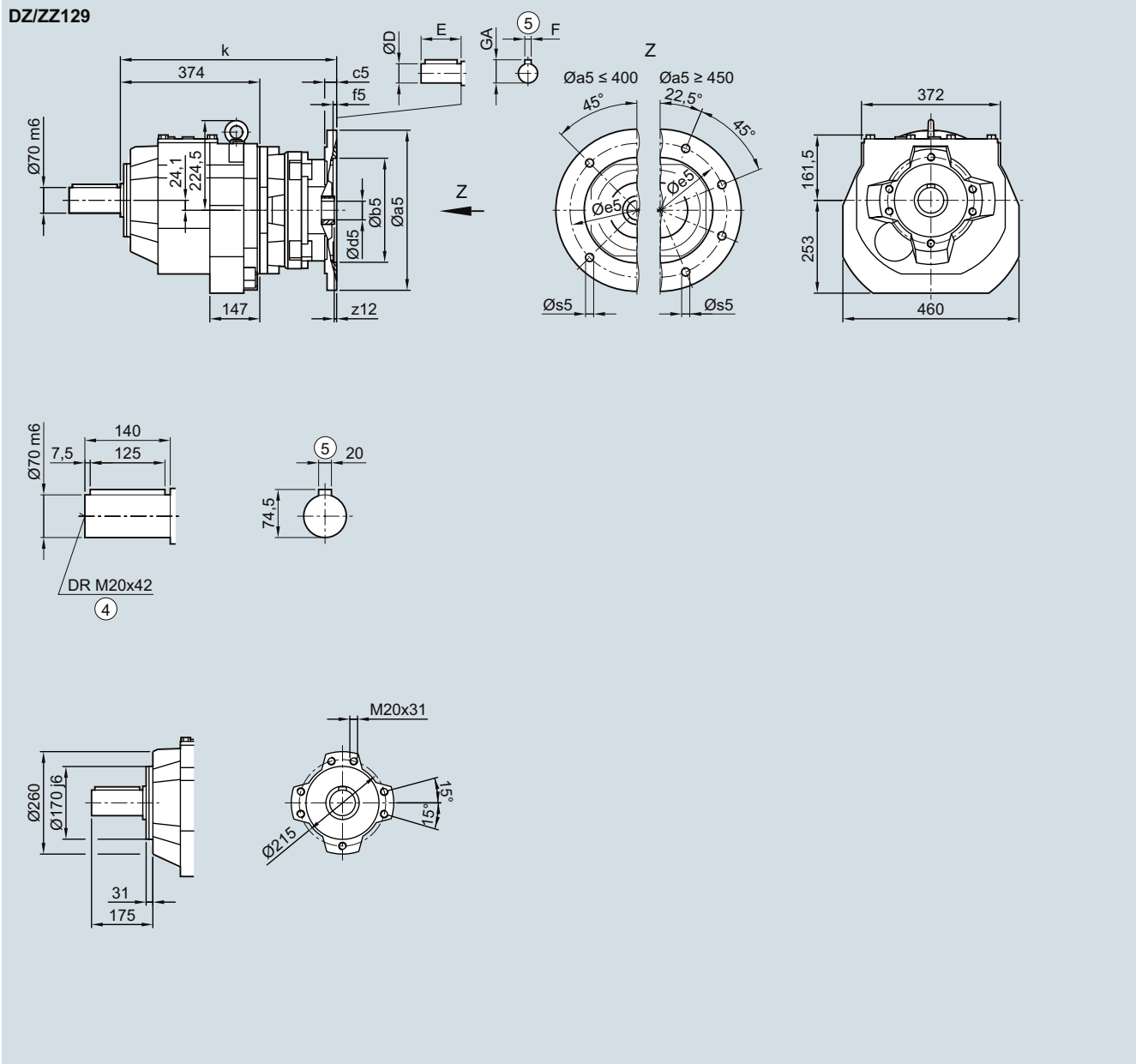

Adapter	a5	b5	c5	f5	e5	s5	z12	d5/D	E	F	GA	k
90	200	130	15	4.5	165	M10	4.0	24	50	8	27.0	437
100	250	180	14	5.0	215	M12x21	7.5	28	60	8	31.0	483.5
112	250	180	14	5.0	215	M12x21	7.5	28	60	8	31.0	483.5
132	300	230	12	5.0	265	M12x20	3.0	38	80	10	41.0	499
160	350	250	15	6.0	300	M16x25	3.0	42	110	12	45.0	529
180	350	250	15	6.0	300	M16x25	3.0	48	110	14	51.5	529
200	400	300	20	6.0	350	M16x29	7.0	55	110	16	59.0	569.5
225	450	350	20	6.0	400	M16x29	7.0	60	140	18	64.0	582
250	550	450	20	6.0	500	M16x29	10.0	65	140	18	69.0	610.5

④ DIN 332

⑤ Feather key/keyway DIN 6885

D/Z149 gearbox in a foot-mounted design

DZ030K4

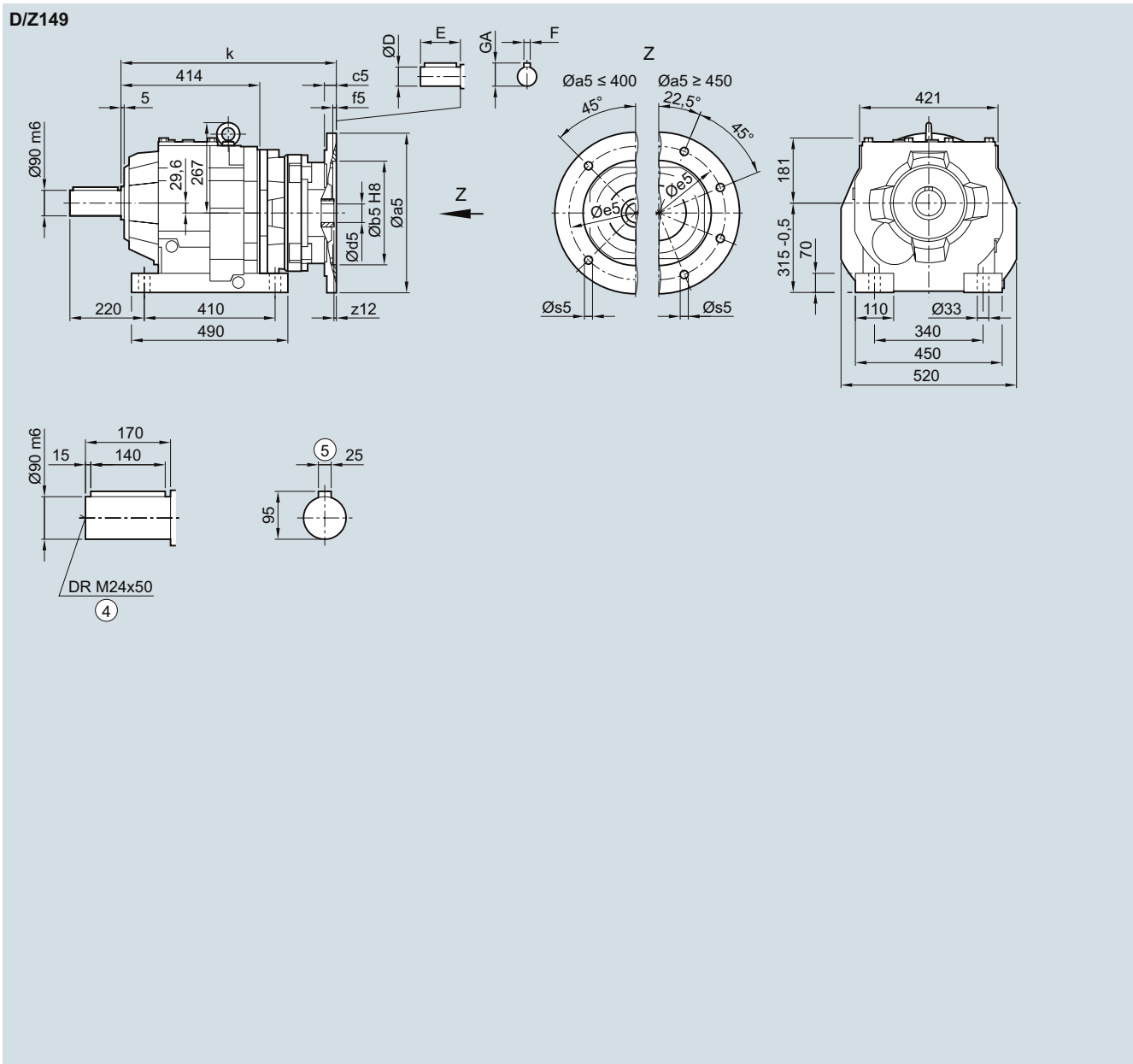

Adapter	a5	b5	c5	f5	e5	s5	z12	d5/D	E	F	GA	k
100	250	180	14	5	215	M12x21	7.5	28	60	8	31.0	522.0
112	250	180	14	5	215	M12x21	7.5	28	60	8	31.0	522.0
132	300	230	12	5	265	M12x20	3.0	38	80	10	41.0	532.5
160	350	250	15	6	300	M16x25	3.0	42	110	12	45.0	562.5
180	350	250	15	6	300	M16x25	3.0	48	110	14	51.5	562.5
200	400	300	20	6	350	M16x29	7.0	55	110	16	59.0	603.0
225	450	350	20	6	400	M16x29	7.0	60	140	18	64.0	609.5
250	550	450	20	6	500	M16x29	10.0	65	140	18	69.0	644.0

④ DIN 332

⑤ Feather key/keyway DIN 6885

SIMOGEAR Gearboxes

Helical gearbox with adapter K4

Dimensions

DF/ZF149 gearbox in a flange-mounted design

DZF030K4

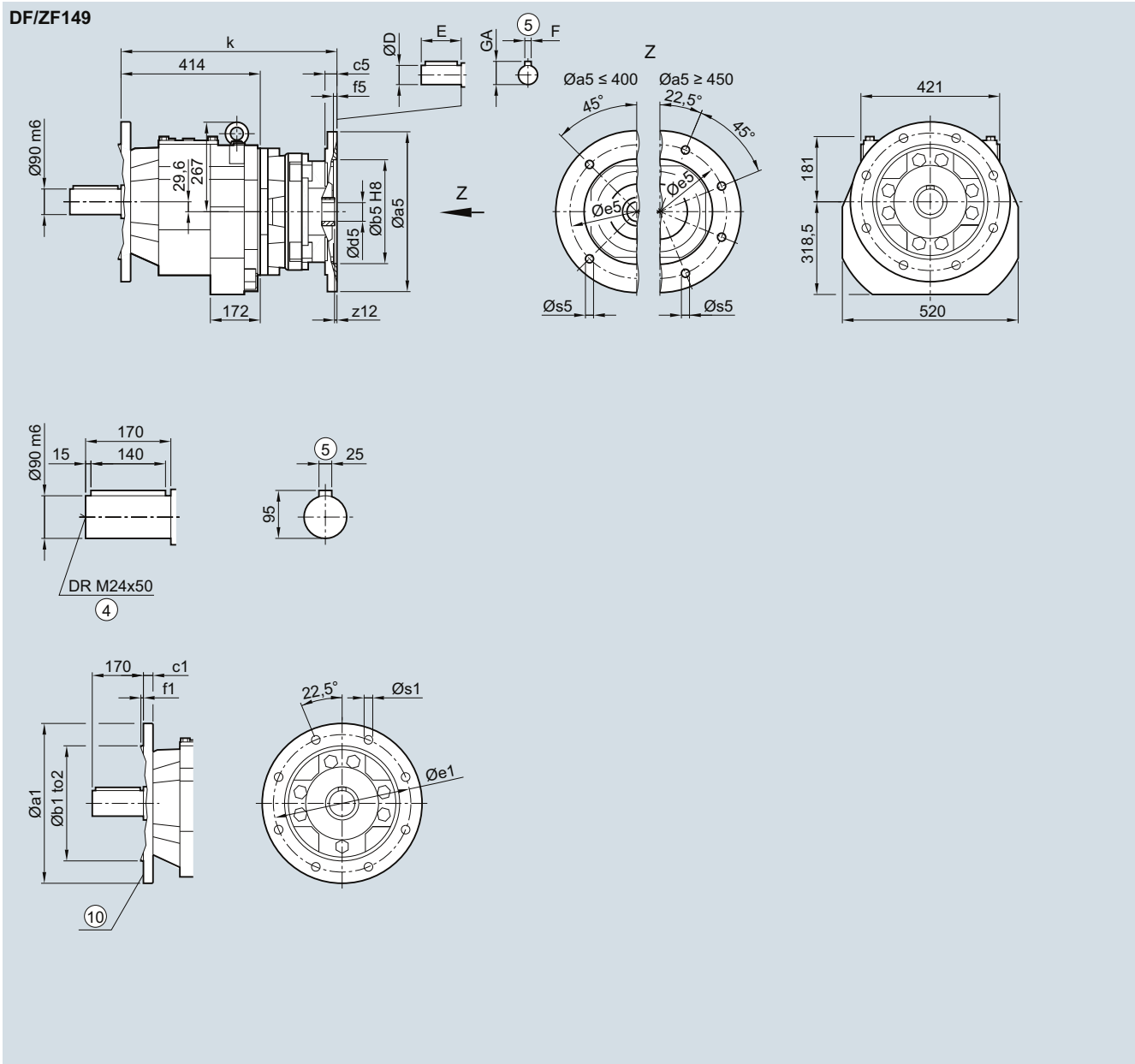

Flange	a1	b1	to2	c1	e1	f1	s1					
	450	350	h6	22	400	5	17.5					
	550	450	h6	25	500	5	17.5					
Adapter	a5	b5	c5	f5	e5	s5	z12	d5/D	E	F	GA	k
100	250	180	14	5	215	M12x21	7.5	28	60	8	31.0	522.0
112	250	180	14	5	215	M12x21	7.5	28	60	8	31.0	522.0
132	300	230	12	5	265	M12x20	3.0	38	80	10	41.0	532.5
160	350	250	15	6	300	M16x25	3.0	42	110	12	45.0	562.5
180	350	250	15	6	300	M16x25	3.0	48	110	14	51.5	562.5
200	400	300	20	6	350	M16x29	7.0	55	110	16	59.0	603.0
225	450	350	20	6	400	M16x29	7.0	60	140	18	64.0	609.5
250	550	450	20	6	500	M16x29	10.0	65	140	18	69.0	644.0

④ DIN 332

Ⓣ For inner contour, see page 3/111

⑤ Feather key/keyway DIN 6885

D/Z169 gearbox in a foot-mounted design

DZ030K4

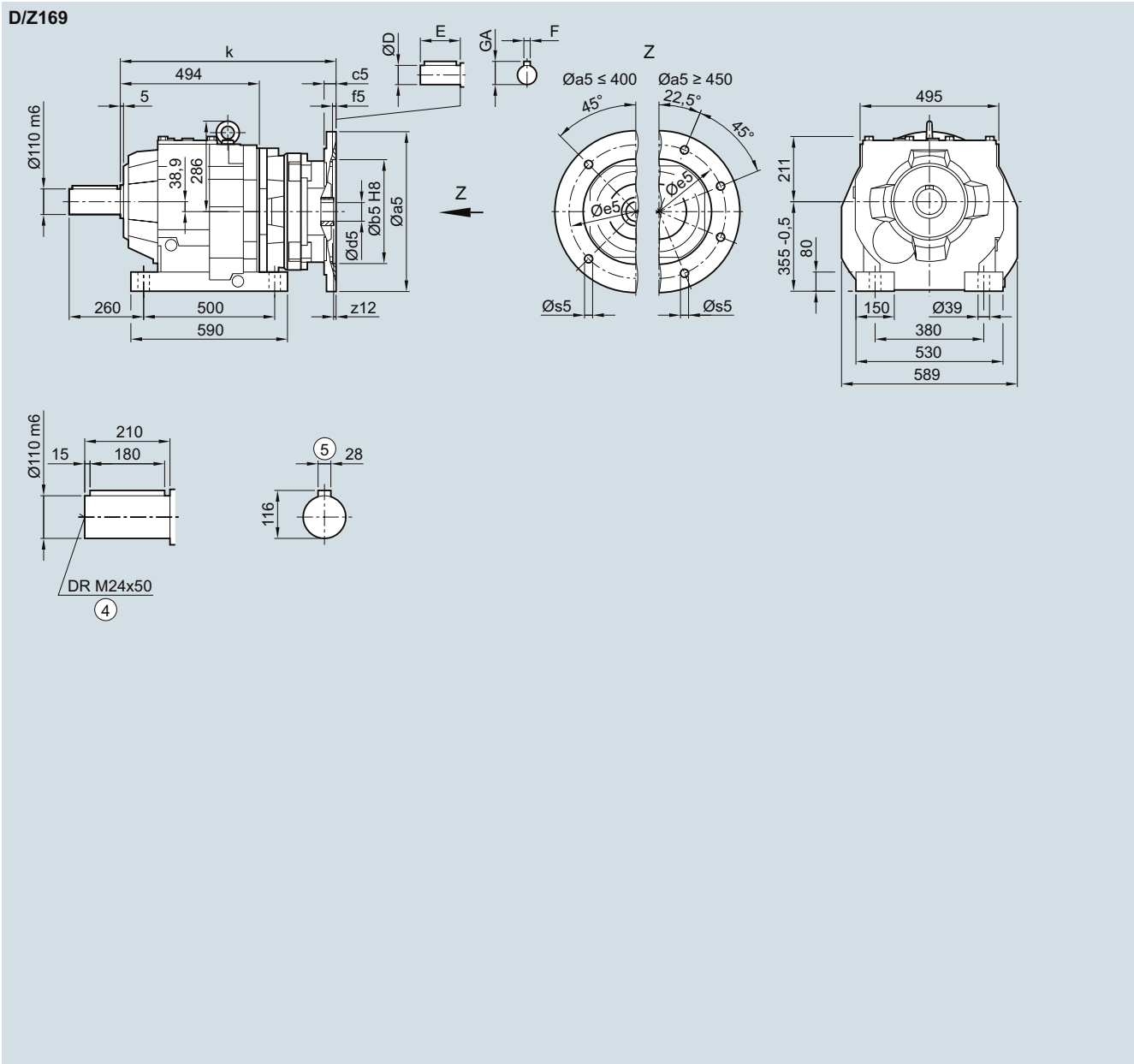

Adapter	a5	b5	c5	f5	e5	s5	z12	d5/D	E	F	GA	k
112	250	180	14	5	215	M12x21	7.5	28	60	8	31.0	589.5
132	300	230	12	5	265	M12x20	3.0	38	80	10	41.0	599.5
160	350	250	15	6	300	M16x25	3.0	42	110	12	45.0	629.5
180	350	250	15	6	300	M16x25	3.0	48	110	14	51.5	629.5
200	400	300	20	6	350	M16x29	7.0	55	110	16	59.0	669.5
225	450	350	20	6	400	M16x29	7.0	60	140	18	64.0	675.0
250	550	450	20	6	500	M16x29	10.0	65	140	18	69.0	705.5

④ DIN 332

⑤ Feather key/keyway DIN 6885

SIMOGEAR Gearboxes

Helical gearbox with adapter K4

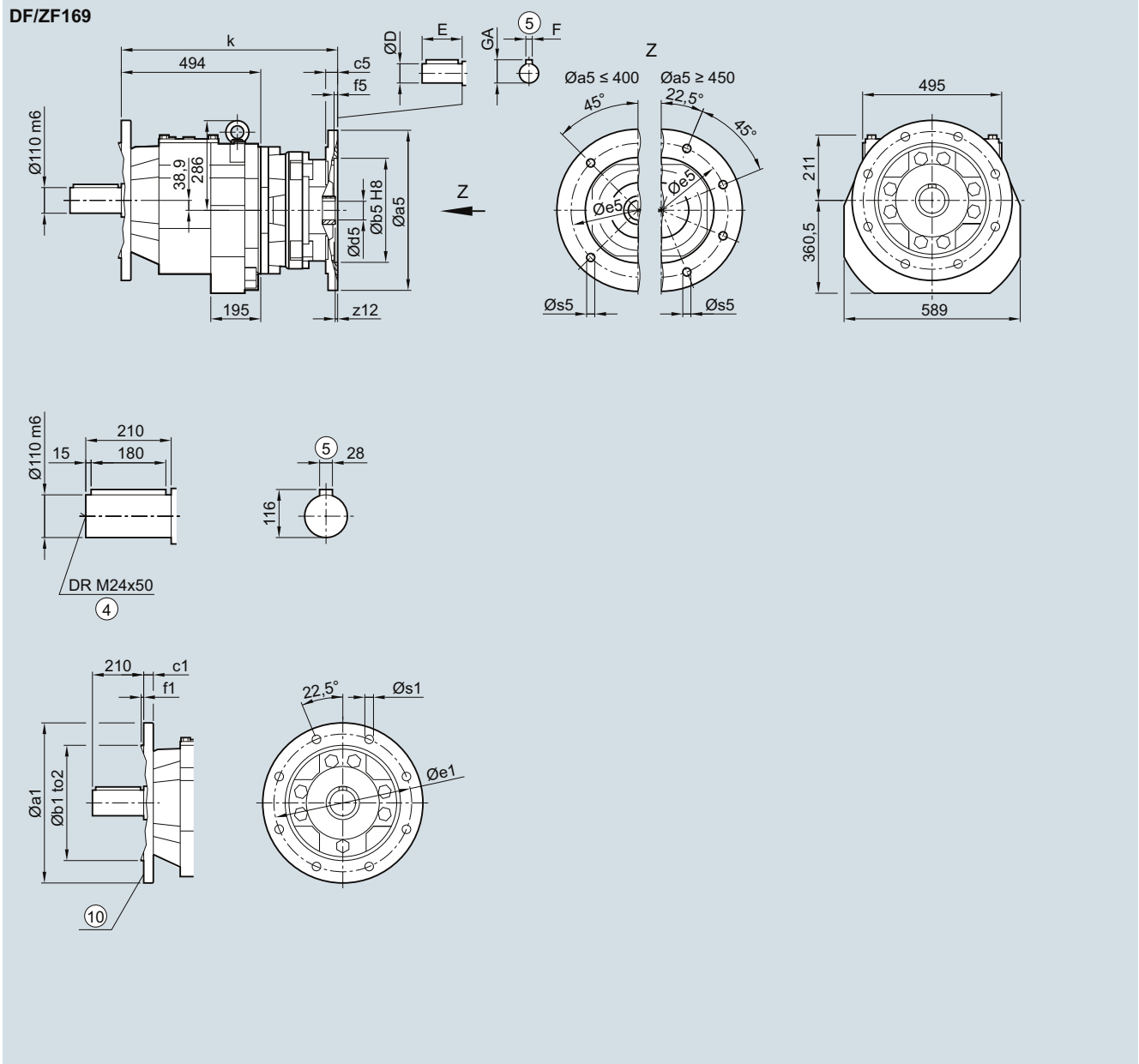
Dimensions**DF/ZF169 gearbox in a flange-mounted design****DZF030K4**

Flange	a1	b1	to2	c1	e1	f1	s1					
	450	350	h6	22	400	5	17.5					
	550	450	h6	25	500	5	17.5					
Adapter	a5	b5	c5	f5	e5	s5	z12	d5/D	E	F	GA	k
112	250	180	14	5	215	M12x21	7.5	28	60	8	31.0	589.5
132	300	230	12	5	265	M12x20	3.0	38	80	10	41.0	599.5
160	350	250	15	6	300	M16x25	3.0	42	110	12	45.0	629.5
180	350	250	15	6	300	M16x25	3.0	48	110	14	51.5	629.5
200	400	300	20	6	350	M16x29	7.0	55	110	16	59.0	669.5
225	450	350	20	6	400	M16x29	7.0	60	140	18	64.0	675.0
250	550	450	20	6	500	M16x29	10.0	65	140	18	69.0	705.5

④ DIN 332

Ⓜ For inner contour, see page 3/111

⑤ Feather key/keyway DIN 6885

D/Z189 gearbox in a foot-mounted design

DZ030K4

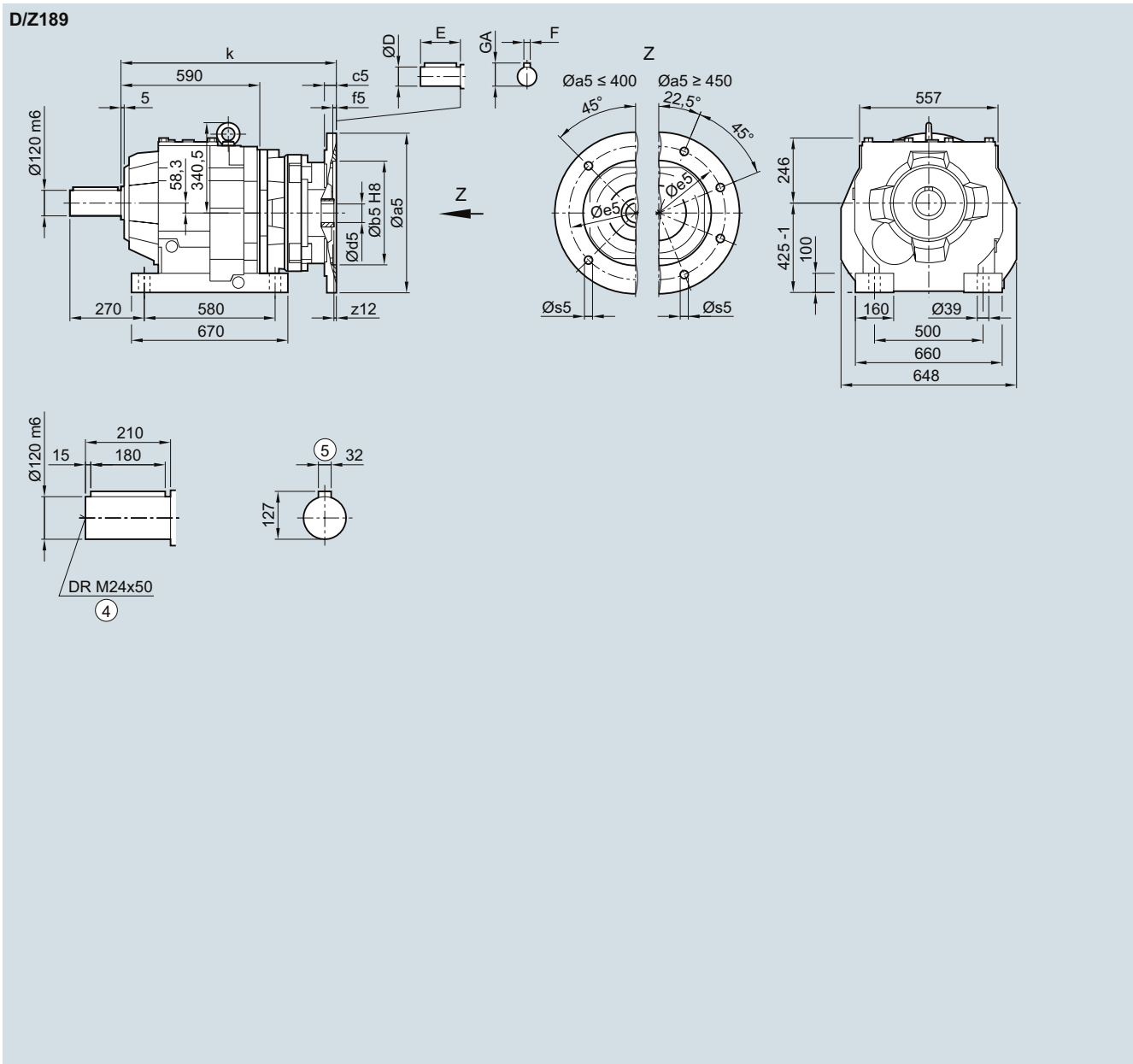

Adapter	a5	b5	c5	f5	e5	s5	z12	d5/D	E	F	GA	k
112	250	180	14	5	215	M12x21	7.5	28	60	8	31.0	685.5
132	300	230	12	5	265	M12x20	3.0	38	80	10	41.0	695.5
160	350	250	15	6	300	M16x25	3.0	42	110	12	45.0	725.5
180	350	250	15	6	300	M16x25	3.0	48	110	14	51.5	725.5
200	400	300	20	6	350	M16x29	7.0	55	110	16	59.0	765.5
225	450	350	20	6	400	M16x29	7.0	60	140	18	64.0	771.0
250	550	450	20	6	500	M16x29	10.0	65	140	18	69.0	801.5

④ DIN 332

⑤ Feather key/keyway DIN 6885

SIMOGEAR Gearboxes

Helical gearbox with adapter K4

Dimensions

DF/ZF189 gearbox in a flange-mounted design

DZF030K4

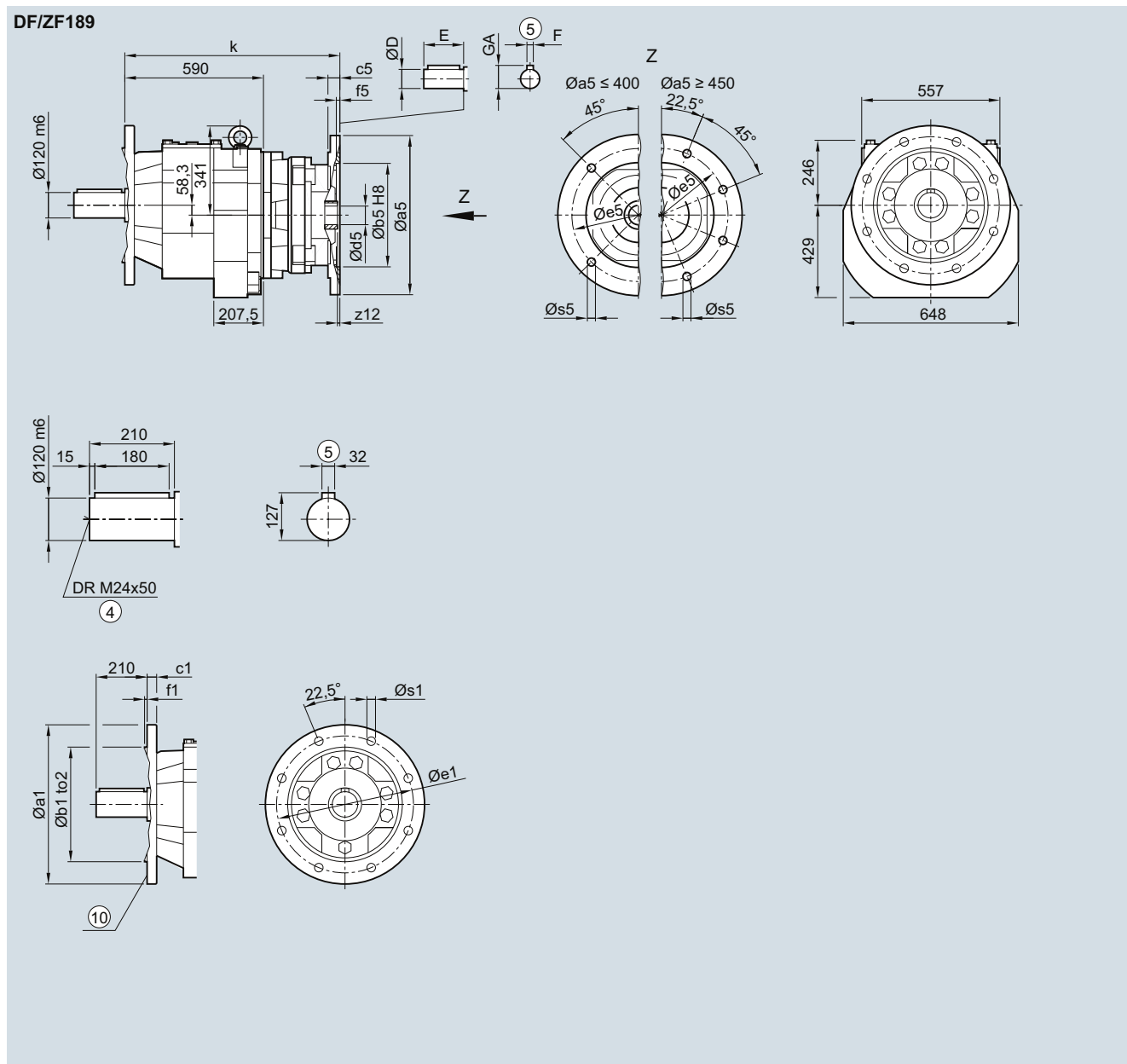

Flange	a1	b1	to2	c1	e1	f1	s1					
	550	450	h6	25	500	5	17.5					
	660	550	h6	28	600	6	22.0					
Adapter	a5	b5	c5	f5	e5	s5	z12	d5/D	E	F	GA	k
112	250	180	14	5	215	M12x21	7.5	28	60	8	31.0	685.5
132	300	230	12	5	265	M12x20	3.0	38	80	10	41.0	695.5
160	350	250	15	6	300	M16x25	3.0	42	110	12	45.0	725.5
180	350	250	15	6	300	M16x25	3.0	48	110	14	51.5	725.5
200	400	300	20	6	350	M16x29	7.0	55	110	16	59.0	765.5
225	450	350	20	6	400	M16x29	7.0	60	140	18	64.0	771.0
250	550	450	20	6	500	M16x29	10.0	65	140	18	69.0	801.5

④ DIN 332

Ⓜ For inner contour, see page 3/111

⑤ Feather key/keyway DIN 6885

D./Z.29 to D./Z.69 gearboxes

DZ030K2, DZB030K2, DZF030K2, DZZ030K2

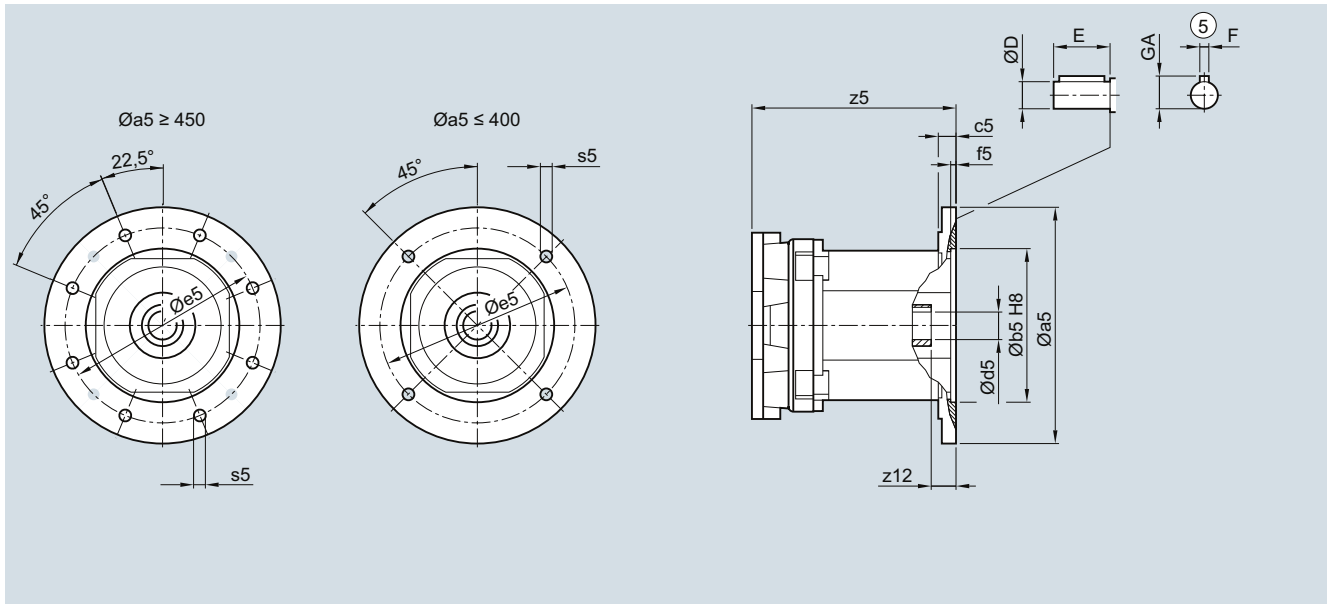

Adapter	a5	b5	c5	f5	e5	s5	z12	d5/D	E	F	GA	z5
D./Z.29												
80	200	130	15	4.5	165	M10	15	19	40	6	21.5	198.0
90	200	130	15	4.5	165	M10	25	24	50	8	27.0	198.0
100	250	180	18	5.0	215	M12	30	28	60	8	31.0	245.0
D./Z.39												
80	200	130	15	4.5	165	M10	15	19	40	6	21.5	198.0
90	200	130	15	4.5	165	M10	25	24	50	8	27.0	198.0
100	250	180	18	5.0	215	M12	30	28	60	8	31.0	245.0
112	250	180	18	5	215	M12	30	28	60	8	31.0	245.0
D./Z.49												
80	200	130	15	4.5	165	M10	15	19	40	6	21.5	188.5
90	200	130	15	4.5	165	M10	25	24	50	8	27.0	188.5
100	250	180	18	5.0	215	M12	30	28	60	8	31.0	235.5
112	250	180	18	5.0	215	M12	30	28	60	8	31.0	235.5
132	300	230	18	5.0	265	M12	45	38	80	10	41.0	313.5
D./Z.59												
80	200	130	15	4.5	165	M10	15	19	40	6	21.5	188.5
90	200	130	15	4.5	165	M10	25	24	50	8	27.0	188.5
100	250	180	18	5.0	215	M12	30	28	60	8	31.0	235.5
112	250	180	18	5.0	215	M12	30	28	60	8	31.0	235.5
132	300	230	18	5.0	265	M12	45	38	80	10	41.0	313.5
D./Z.69												
80	200	130	15	4.5	165	M10	15	19	40	6	21.5	188.5
90	200	130	15	4.5	165	M10	25	24	50	8	27.0	188.5
100	250	180	18	5.0	215	M12	30	28	60	8	31.0	235.5
112	250	180	18	5.0	215	M12	30	28	60	8	31.0	235.5
132	300	230	18	5.0	265	M12	45	38	80	10	41.0	313.5

© Feather key/keyway DIN 6885

SIMOGEAR Gearboxes

Helical gearbox with adapter K2

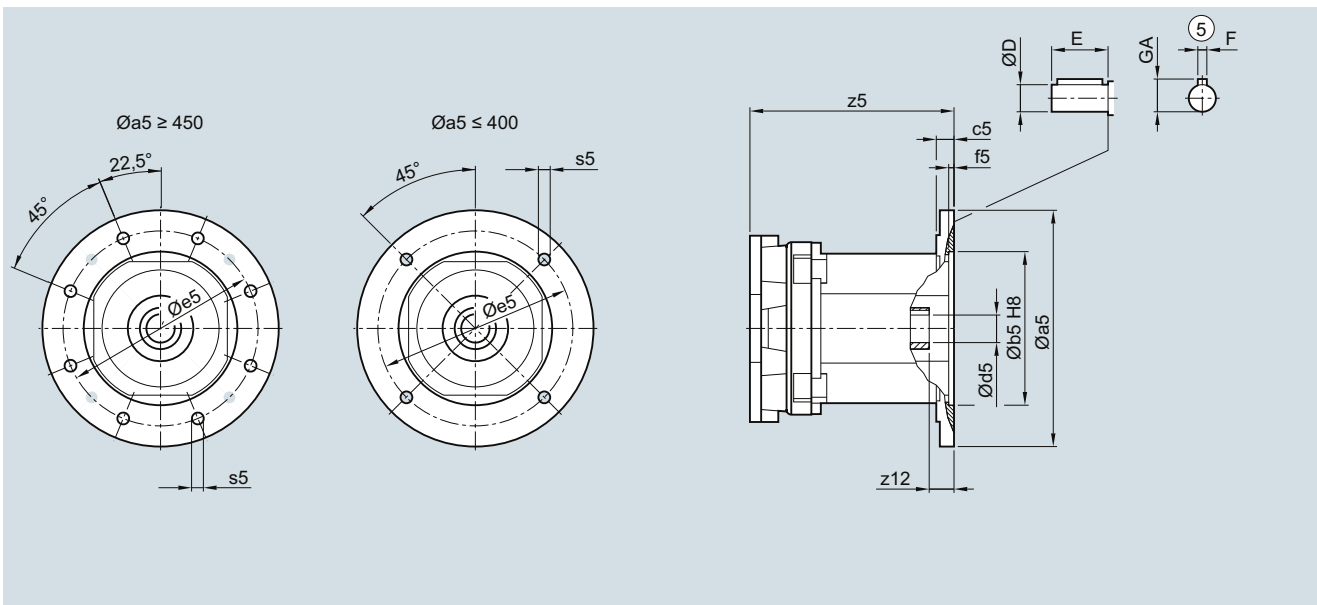
Dimensions**D./Z.79 to D./Z.129 gearboxes****DZ030K2, DZB030K2, DZF030K2, DZZ030K2**

Adapter	a5	b5	c5	f5	e5	s5	z12	d5/D	E	F	GA	z5
D./Z.79												
80	200	130	15	4.5	165	M10	15	19	40	6	21.5	182.5
90	200	130	15	4.5	165	M10	25	24	50	8	27.0	182.5
100	250	180	18	5.0	215	M12	30	28	60	8	31.0	229.5
112	250	180	18	5.0	215	M12	30	28	60	8	31.0	229.5
132	300	230	18	5.0	265	M12	45	38	80	10	41.0	307.5
160	350	250	25	6.0	300	M16	66	42	110	12	45.0	352.5
D./Z.89												
80	200	130	15	4.5	165	M10	15	19	40	6	21.5	169.5
90	200	130	15	4.5	165	M10	25	24	50	8	27.0	169.5
100	250	180	18	5.0	215	M12	30	28	60	8	31.0	212.5
112	250	180	18	5.0	215	M12	30	28	60	8	31.0	212.5
132	300	230	18	5.0	265	M12	45	38	80	10	41.0	290.5
160	350	250	25	6.0	300	M16	66	42	110	12	45.0	335.5
180	350	250	25	6.0	300	M16	59	48	110	14	51.5	335.5
D./Z.109												
90	200	130	15	4.5	165	M10	25	24	50	8	27.0	162.5
100	250	180	18	5	215	M12	30	28	60	8	31.0	203.5
112	250	180	18	5	215	M12	30	28	60	8	31.0	203.5
132	300	230	18	5	265	M12	45	38	80	10	41.0	281.5
160	350	250	25	6	300	M16	66	42	110	12	45.0	326.5
180	350	250	25	6	300	M16	59	48	110	14	51.5	326.5
200	400	300	20	6	350	M16x29	60	55	110	16	59.0	371.5
225	450	350	50	6	400	M16x29	84 (36)	60 (55)	140 (110)	18 (16)	64.0 (59.0)	419.0
D./Z.129												
90	200	130	15	4.5	165	M10	25	24	50	8	27.0	155.5
100	250	180	18	5	215	M12	30	28	60	8	31.0	194.5
112	250	180	18	5	215	M12	30	28	60	8	31.0	194.5
132	300	230	18	5	265	M12	45	38	80	10	41.0	270.5
160	350	250	25	6	300	M16	66	42	110	12	45.0	315.5
180	350	250	25	6	300	M16	59	48	110	14	51.5	315.5
200	400	300	20	6	350	M16x29	60	55	110	16	59.0	360.5
225	450	350	50	6	400	M16x29	84 (36)	60 (55)	140 (110)	18 (16)	64.0 (59.0)	414.0
250	550	450	27	6	500	M16	75	65	140	18	69.0	445.5

③ Feather key/keyway DIN 6885

() Dimension in brackets for 2-pole motor

D./Z.149 to D./Z.189 gearboxes

DZ030K2, DZB030K2, DZF030K2, DZZ030K2

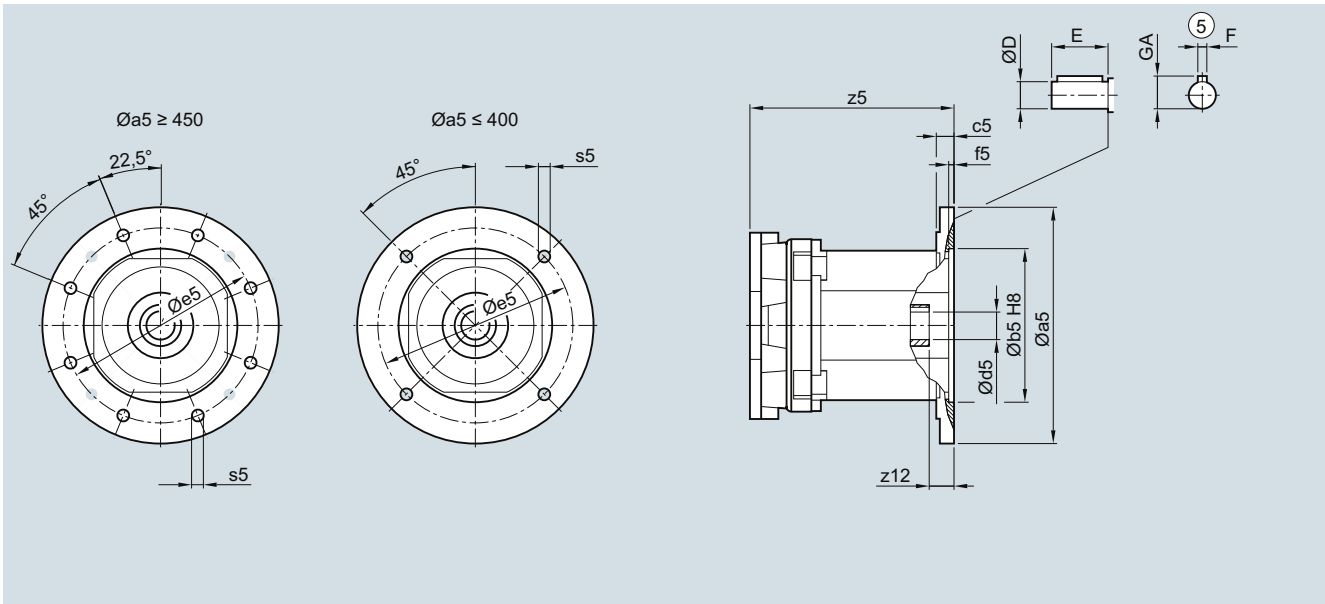

Adapter	a5	b5	c5	f5	e5	s5	z12	d5/D	E	F	GA	z5
D./Z.149												
100	250	180	18	5	215	M12	30	28	60	8	31.0	193.0
112	250	180	18	5	215	M12	30	28	60	8	31.0	193.0
132	300	230	18	5	265	M12	45	38	80	10	41.0	264.0
160	350	250	25	6	300	M16	66	42	110	12	45.0	309.0
180	350	250	25	6	300	M16	59	48	110	14	51.5	309.0
200	400	300	20	6	350	M16x29	60	55	110	16	59.0	354.0
225	450	350	50	6	400	M16x29	84 (36)	60 (55)	140 (110)	18 (16)	64.0 (59.0)	401.5
250	550	450	27	6	500	M16	75	65	140	18	69.0	439.0
280	550	450	27	6	500	M16	51	75 (65)	140	20 (18)	79.5 (69.0)	314.5
D./Z.169												
112	250	180	18	5	215	M12	30	28	60	8	31.0	180.5
132	300	230	18	5	265	M12	45	38	80	10	41.0	251.0
160	350	250	25	6	300	M16	66	42	110	12	45.0	296.0
180	350	250	25	6	300	M16	59	48	110	14	51.5	296.0
200	400	300	20	6	350	M16x29	60	55	110	16	59.0	340.5
225	450	350	50	6	400	M16x29	84 (36)	60 (55)	140 (110)	18 (16)	64.0 (59.0)	387.0
250	550	450	27	6	500	M16	75	65	140	18	69.0	420.5
280	550	450	27	6	500	M16	51	75 (65)	140	20 (18)	79.5 (69.0)	297.5
D./Z.189												
112	250	180	18	5	215	M12	30	28	60	8	31.0	180.5
132	300	230	18	5	265	M12	45	38	80	10	41.0	251.0
160	350	250	25	6	300	M16	66	42	110	12	45.0	296.0
180	350	250	25	6	300	M16	59	48	110	14	51.5	296.0
200	400	300	20	6	350	M16x29	60	55	110	16	59.0	340.5
225	450	350	50	6	400	M16x29	84 (36)	60 (55)	140 (110)	18 (16)	64.0 (59.0)	387.0
250	550	450	27	6	500	M16	75	65	140	18	69.0	420.5
280	550	450	27	6	500	M16	51	75 (65)	140	20 (18)	79.5 (69.0)	297.5
315	660	550	33	8	600	M20	33.5	80 (65)	170 (140)	22 (18)	85.0 (69.0)	321.5

⑨ Feather key/keyway DIN 6885

() Dimension in brackets for 2-pole motor

SIMOGEAR Gearboxes

Helical gearbox with adapter KQ

Dimensions

D/Z29 gearbox in a foot-mounted design

DZ030KQ

D/Z29

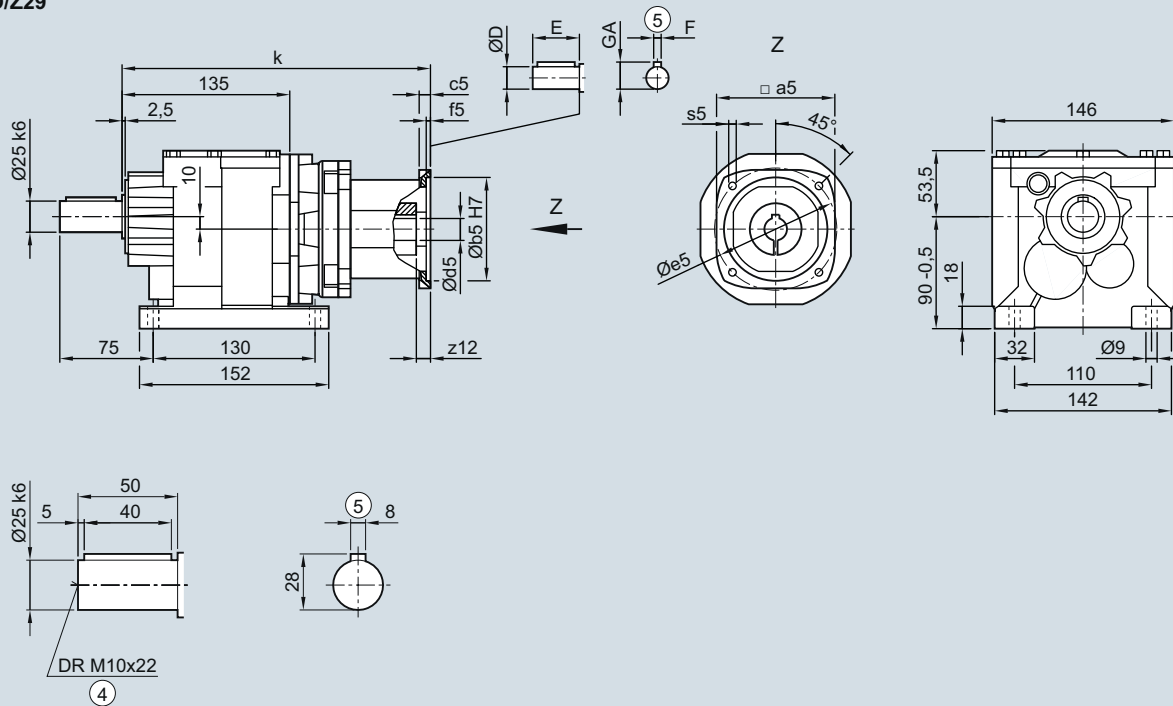

Adapter	a5	b5	c5	f5	e5	s5	z12	d5/D	E	F	GA	k
703	71.6	60	9	4.0	75	M5	18	14	30	5	16.0	234.5
704	96.5	80	10	4.0	100	M6	14	19	40	6	21.5	281.5
706	126.0	110	12	4.5	130	M8	15	24	50	8	27.0	294.5

④ DIN 332

⑤ Feather key/keyway DIN 6885

DB/ZB29 gearbox in a foot/flange-mounted design

DZB030KQ

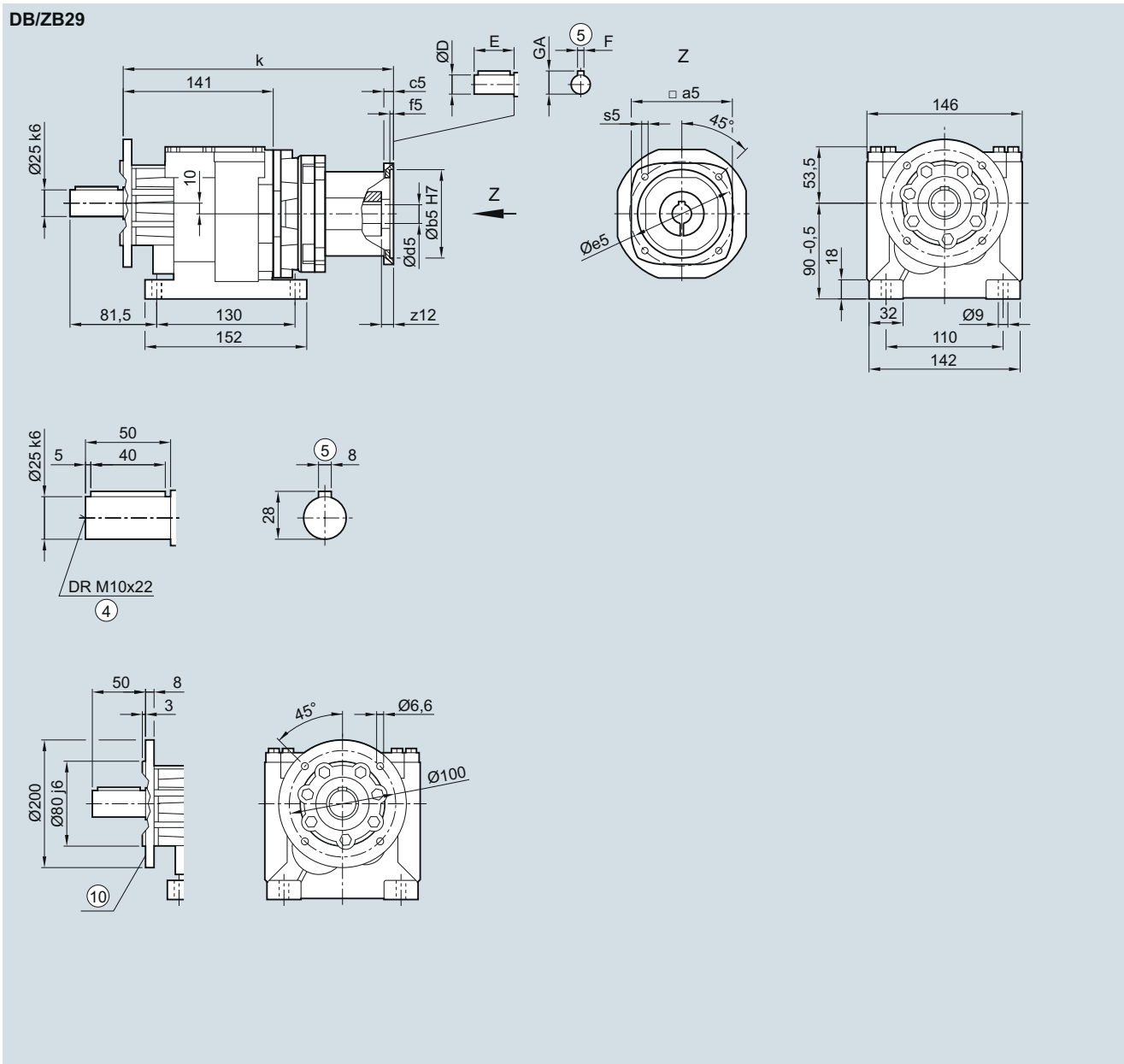

Adapter	a5	b5	c5	f5	e5	s5	z12	d5/D	E	F	GA	k
703	71.6	60	9	4.0	75	M5	18	14	30	5	16.0	240.5
704	96.5	80	10	4.0	100	M6	14	19	40	6	21.5	287.5
706	126.0	110	12	4.5	130	M8	15	24	50	8	27.0	300.5

④ DIN 332

Ⓜ For inner contour, see page 3/111

⑤ Feather key/keyway DIN 6885

SIMOGEAR Gearboxes

Helical gearbox with adapter KQ

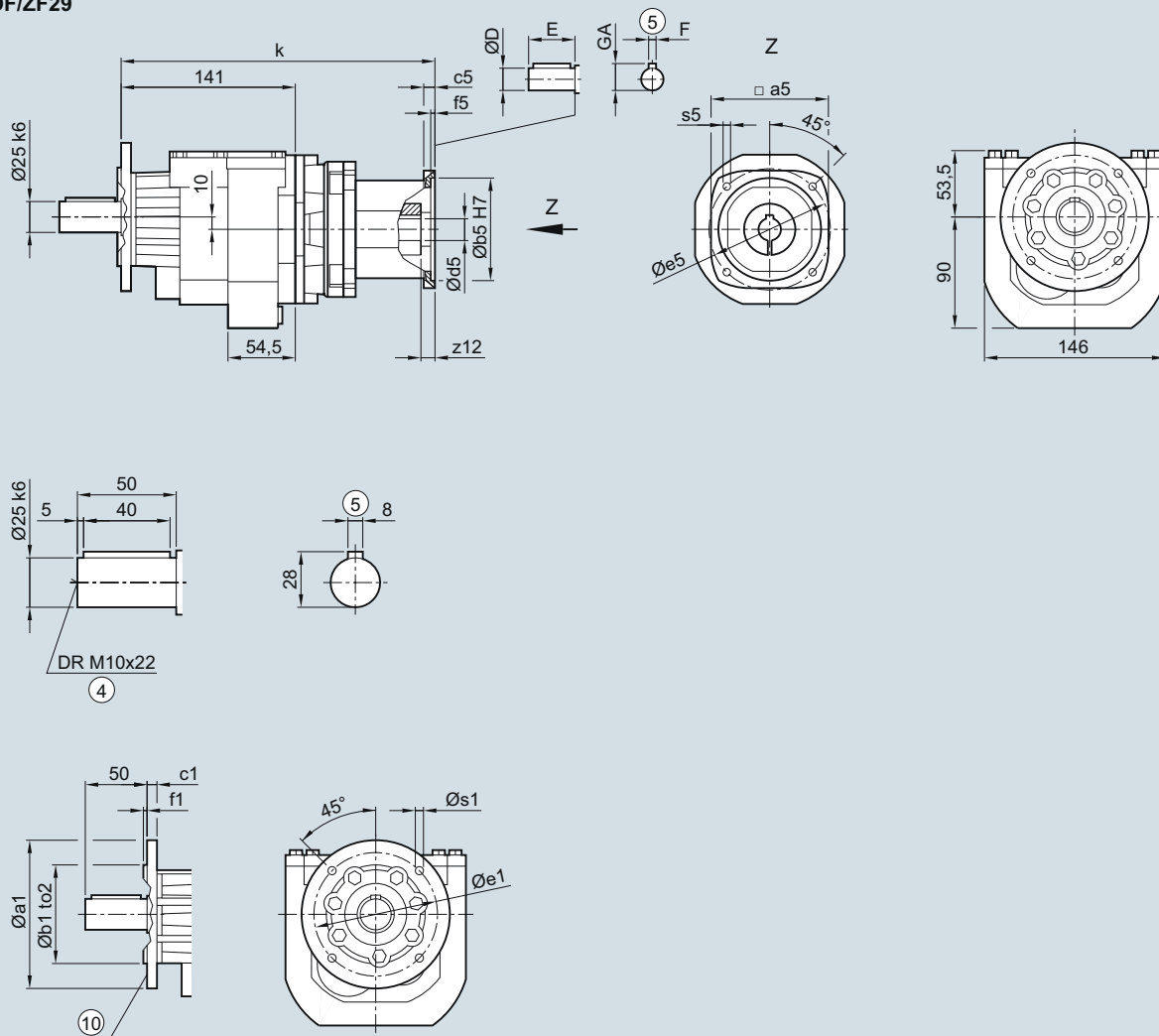
Dimensions**DF/ZF29 gearbox in a flange-mounted design****DZF030KQ****DF/ZF29**

Flange	a1	b1	to2	c1	e1	f1	s1					
	120	80	j6	8	100	3.0	6.6					
	140	95	j6	9	115	3.0	9.0					
	160	110	j6	9	130	3.5	9.0					
Adapter	a5	b5	c5	f5	e5	s5	z12	d5/D	E	F	GA	k
703	71.6	60	9	4.0	75	M5	18	14	30	5	16.0	240.5
704	96.5	80	10	4.0	100	M6	14	19	40	6	21.5	287.5
706	126.0	110	12	4.5	130	M8	15	24	50	8	27.0	300.5

④ DIN 332

Ⓣ For inner contour, see page 3/111

⑤ Feather key/keyway DIN 6885

DZ/ZZ29 gearbox in a housing flange design

DZZ030KQ

DZ/ZZ29

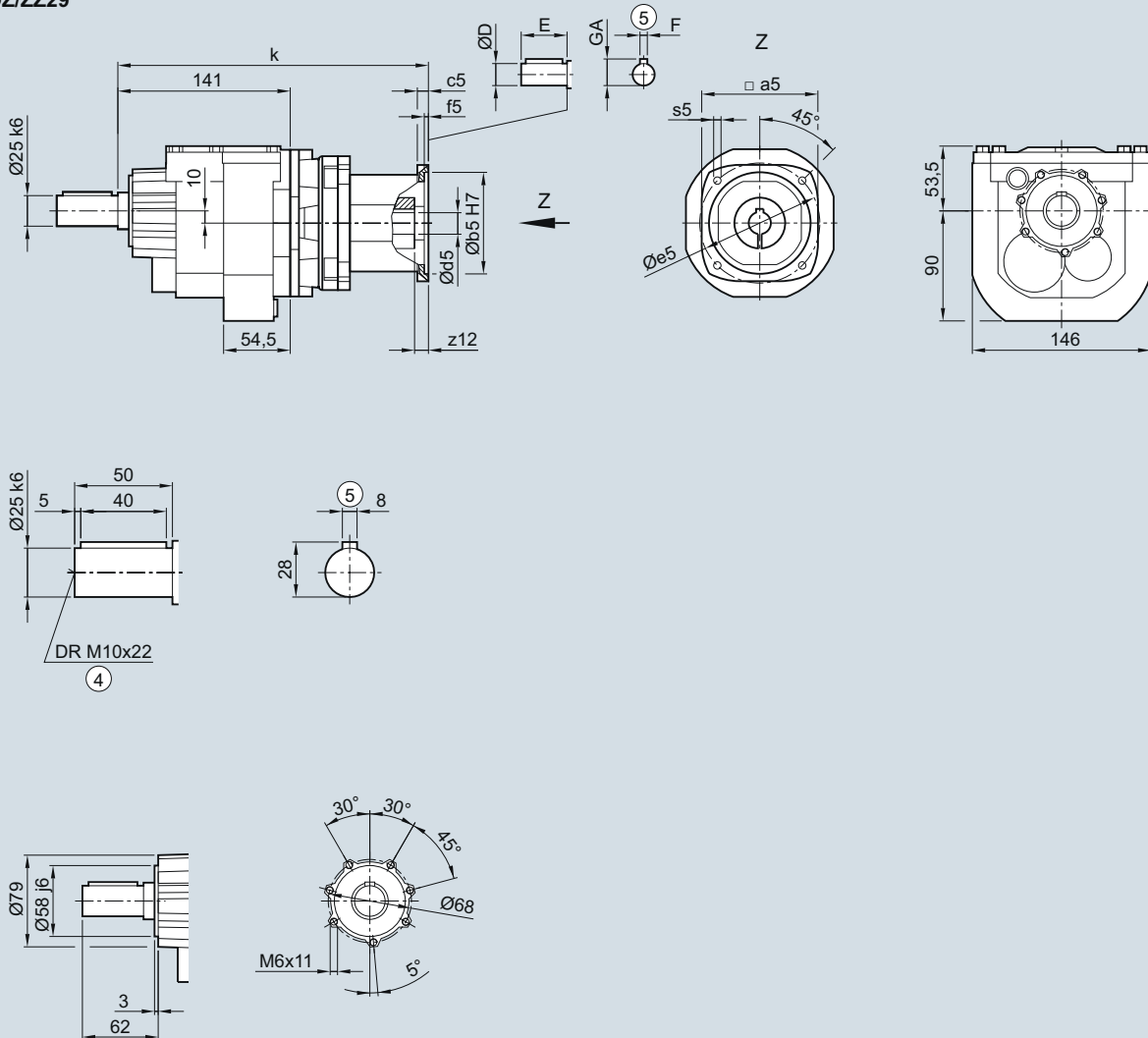

Adapter	a5	b5	c5	f5	e5	s5	z12	d5/D	E	F	GA	k
703	71.6	60	9	4.0	75	M5	18	14	30	5	16.0	240.5
704	96.5	80	10	4.0	100	M6	14	19	40	6	21.5	287.5
706	126.0	110	12	4.5	130	M8	15	24	50	8	27.0	300.5

④ DIN 332

⑤ Feather key/keyway DIN 6885

SIMOGEAR Gearboxes

Helical gearbox with adapter KQ

Dimensions

D/Z39 gearbox in a foot-mounted design

DZ030KQ

D/Z39

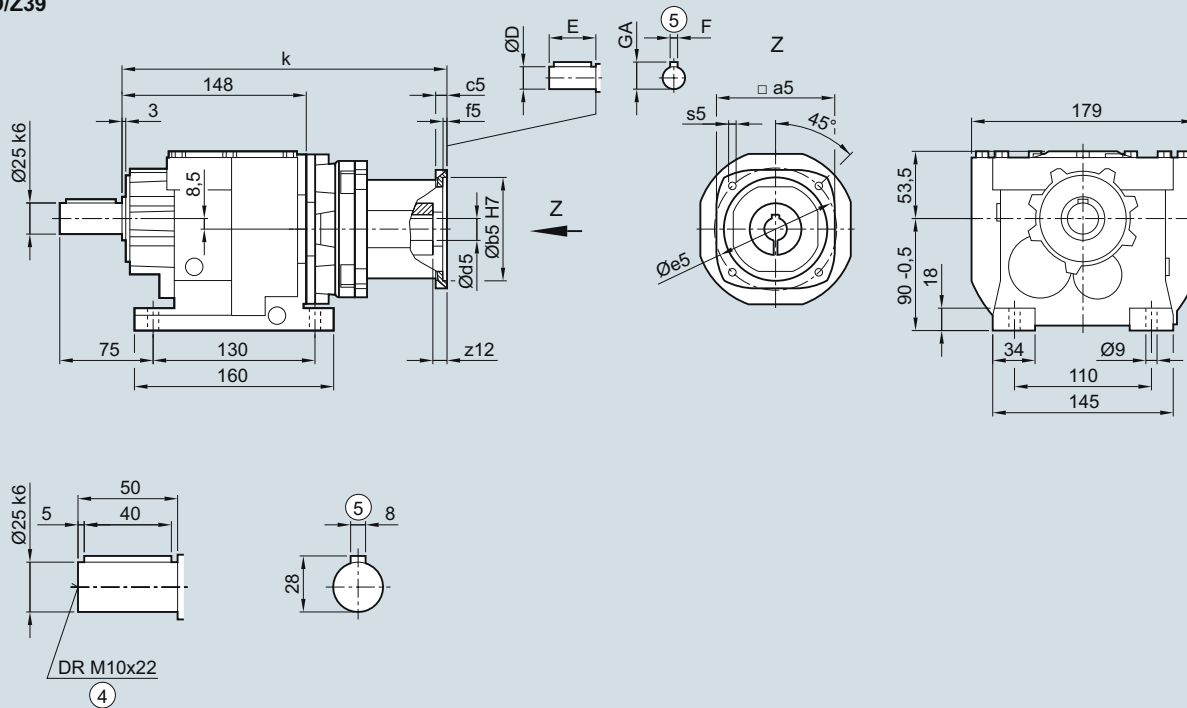

Adapter	a5	b5	c5	f5	e5	s5	z12	d5/D	E	F	GA	k
703	71.6	60	9	4.0	75	M5	18.0	14	30	5	16.0	247.5
704	96.5	80	10	4.0	100	M6	14.0	19	40	6	21.5	294.5
706	126.0	110	12	4.5	130	M8	15.0	24	50	8	27.0	307.5
708	155.0	130	15	4.5	165	M10	23.5	32	58	10	35.0	351.0

④ DIN 332

⑤ Feather key/keyway DIN 6885

DB/ZB39 gearbox in a foot/flange-mounted design

DZB030KQ

DZ/ZZ39

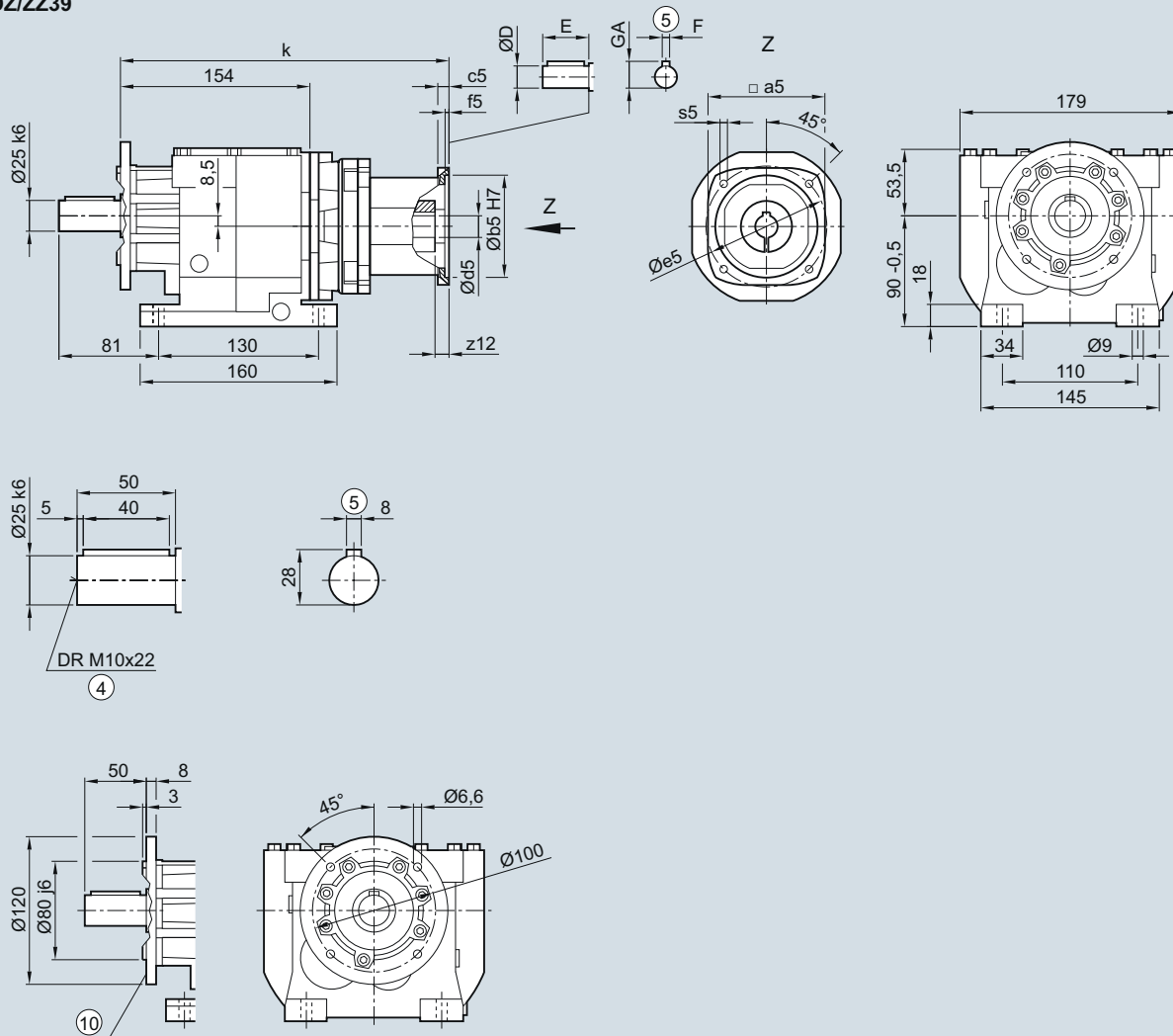

Adapter	a5	b5	c5	f5	e5	s5	z12	d5/D	E	F	GA	k
703	71.6	60	9	4.0	75	M5	18.0	14	30	5	16.0	253.5
704	96.5	80	10	4.0	100	M6	14.0	19	40	6	21.5	300.5
706	126.0	110	12	4.5	130	M8	15.0	24	50	8	27.0	313.5
708	155.0	130	15	4.5	165	M10	23.5	32	58	10	35.0	357.0

④ DIN 332

Ⓜ For inner contour, see page 3/111

⑤ Feather key/keyway DIN 6885

SIMOGEAR Gearboxes

Helical gearbox with adapter KQ

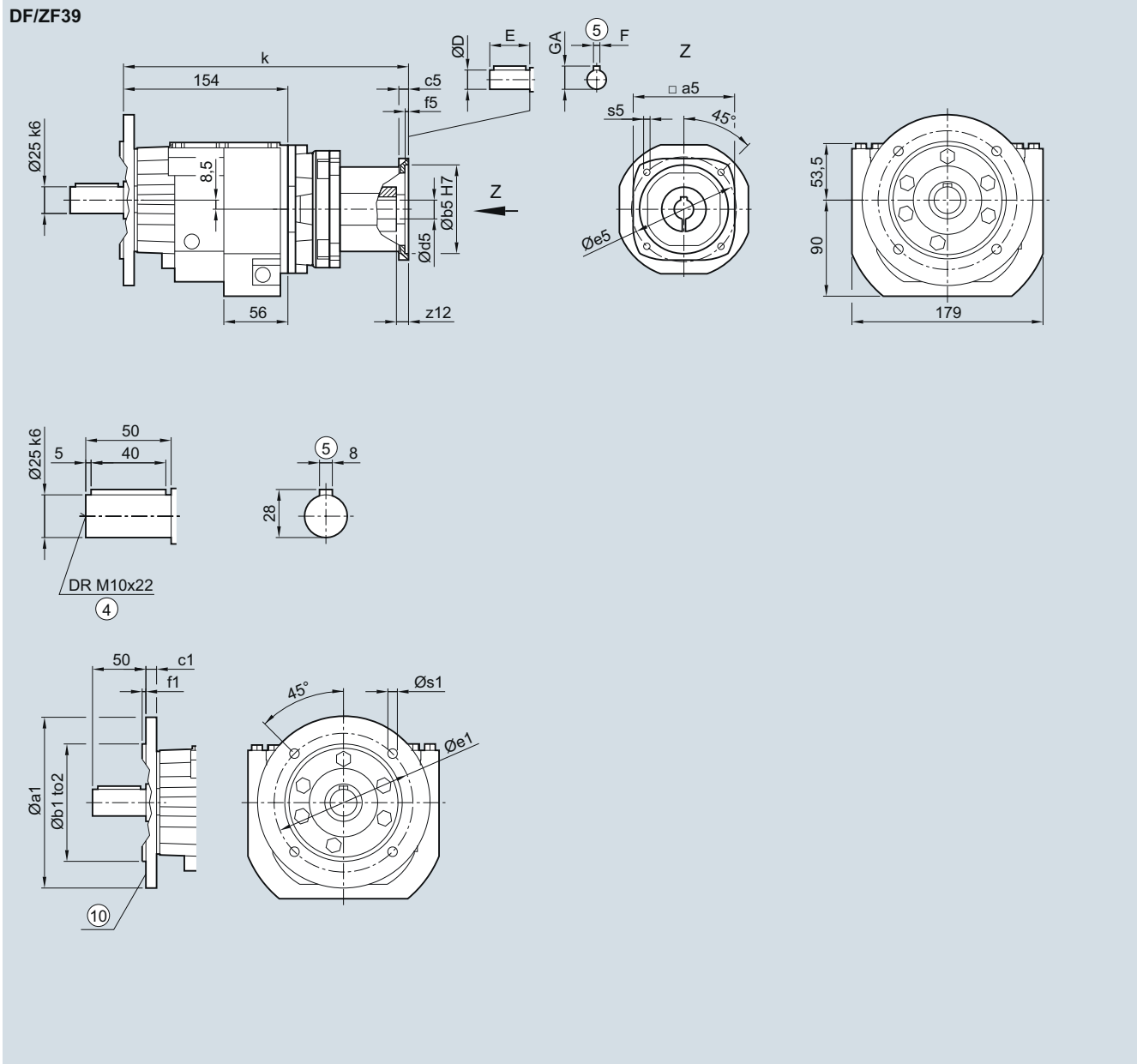
Dimensions**DF/ZF39 gearbox in a flange-mounted design****DZF030KQ**

Flange	a1	b1	to2	c1	e1	f1	s1					
	120	80	j6	8	100	3.0	6.6					
	160	110	j6	10	130	3.5	9.0					
	200	130	j6	12	165	3.5	11.0					
Adapter	a5	b5	c5	f5	e5	s5	z12	d5/D	E	F	GA	k
703	71.6	60	9	4.0	75	M5	18.0	14	30	5	16.0	253.5
704	96.5	80	10	4.0	100	M6	14.0	19	40	6	21.5	300.5
706	126.0	110	12	4.5	130	M8	15.0	24	50	8	27.0	313.5
708	155.0	130	15	4.5	165	M10	23.5	32	58	10	35.0	357.0

④ DIN 332

Ⓣ For inner contour, see page 3/111

⑤ Feather key/keyway DIN 6885

DZ/ZZ39 gearbox in a housing flange design

DZZ030KQ

DZ/ZZ39

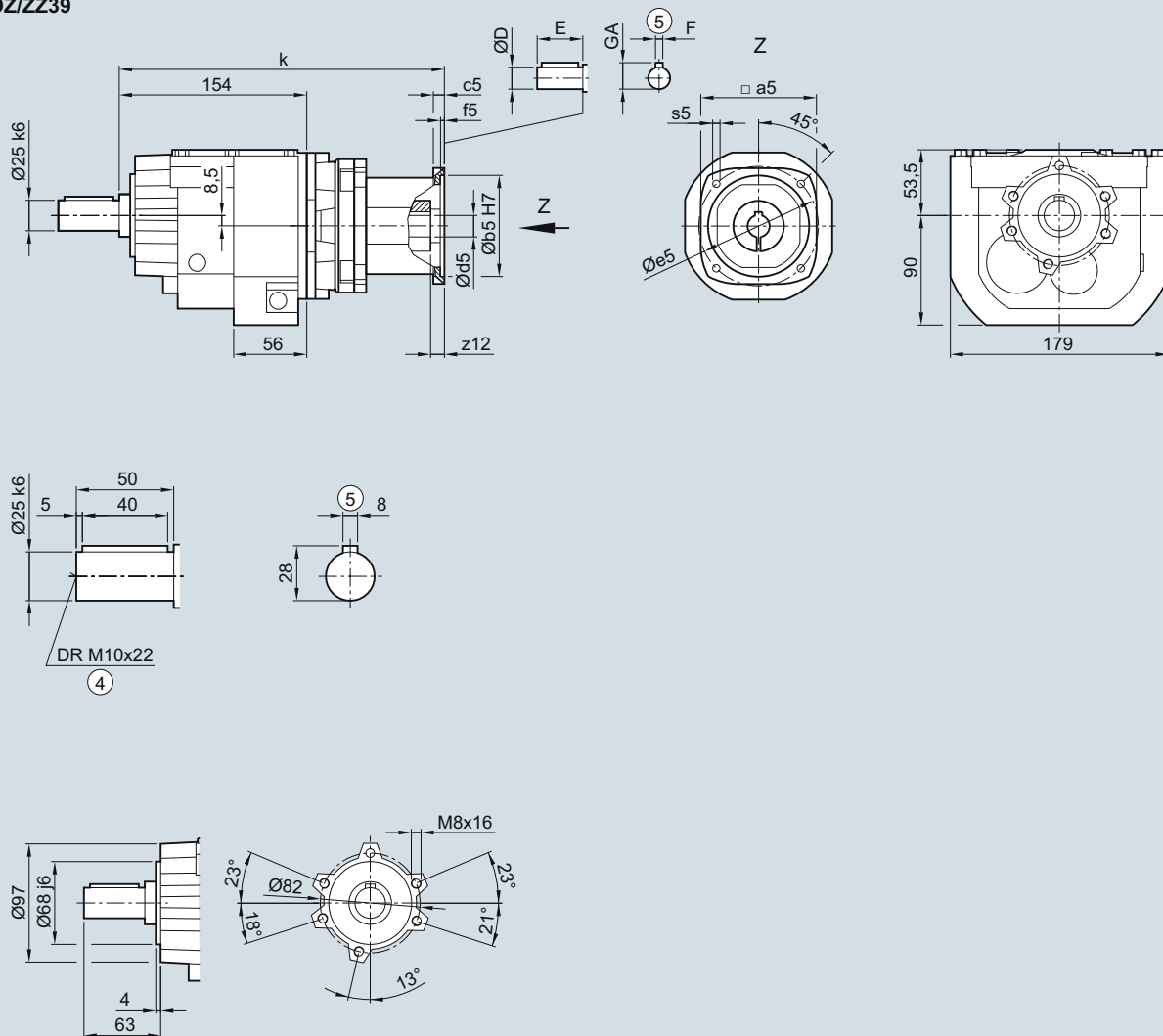

3

Adapter	a5	b5	c5	f5	e5	s5	z12	d5/D	E	F	GA	k
703	71.6	60	9	4.0	75	M5	18.0	14	30	5	16.0	253.5
704	96.5	80	10	4.0	100	M6	14.0	19	40	6	21.5	300.5
706	126.0	110	12	4.5	130	M8	15.0	24	50	8	27.0	313.5
708	155.0	130	15	4.5	165	M10	23.5	32	58	10	35.0	357.0

④ DIN 332

⑤ Feather key/keyway DIN 6885

SIMOGEAR Gearboxes

Helical gearbox with adapter KQ

Dimensions

D/Z49 and DB/ZB49 gearboxes in a foot and foot/flange-mounted design

DZ030, DZB030KQ

D/Z49

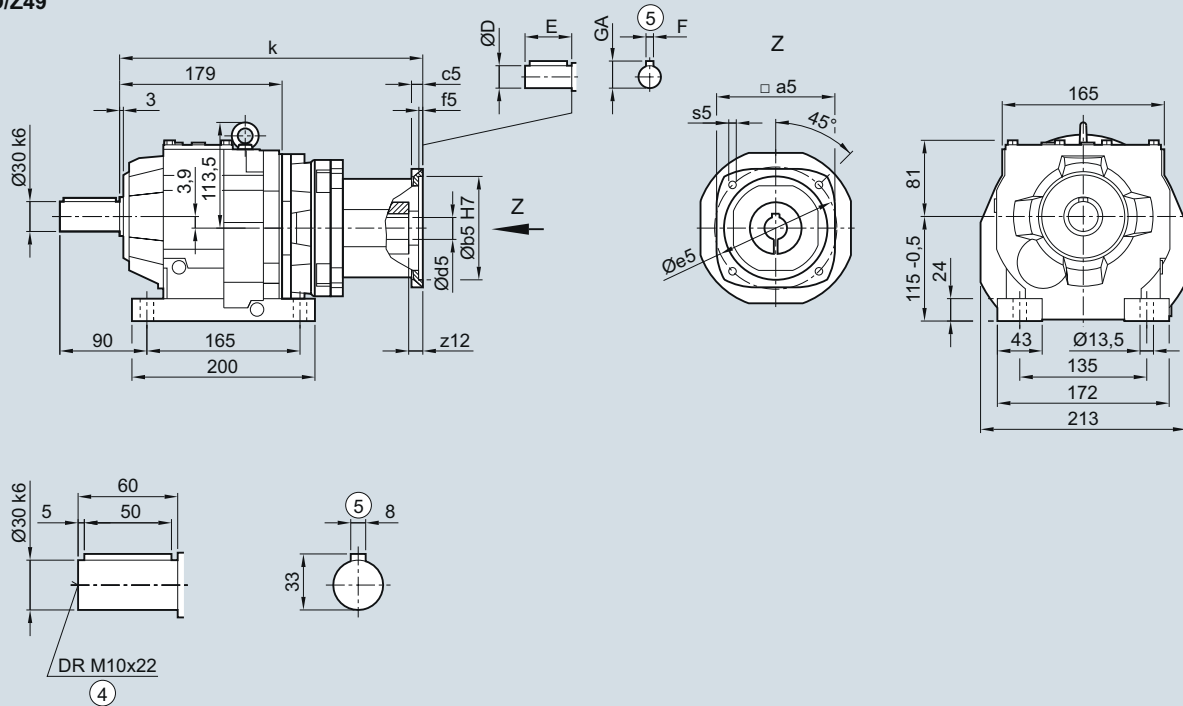

DB/ZB49

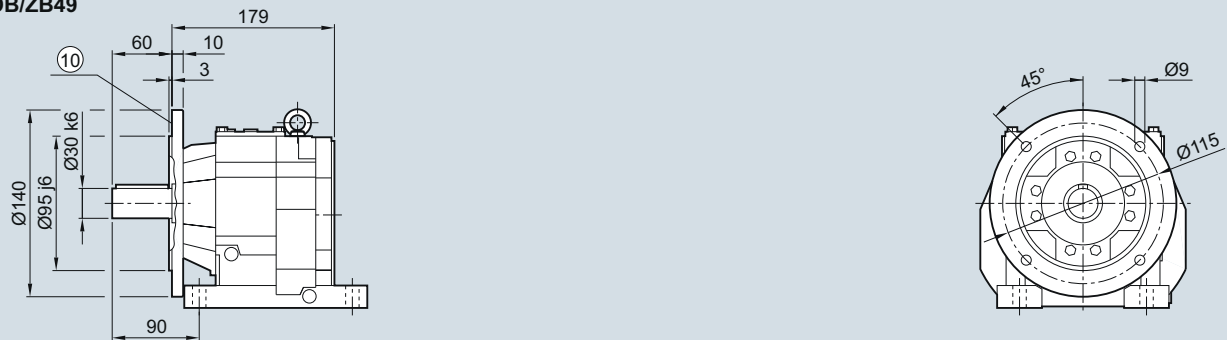

Adapter	a5	b5	c5	f5	e5	s5	z12	d5/D	E	F	GA	k
703	71.6	60	9	4.0	75	M5	18.0	14	30	5	16.0	269.0
704	96.5	80	10	4.0	100	M6	14.0	19	40	6	21.5	316.0
706	126.0	110	12	4.5	130	M8	15.0	24	50	8	27.0	329.0
708	155.0	130	15	4.5	165	M10	23.5	32	58	10	35.0	372.5
710	192.5	180	18	5.0	215	M12	33.0	38	80	10	41.0	441.5

④ DIN 332

Ⓜ For inner contour, see page 3/111

⑤ Feather key/keyway DIN 6885

DF/ZF49 gearbox in a flange-mounted design

DZF030KQ

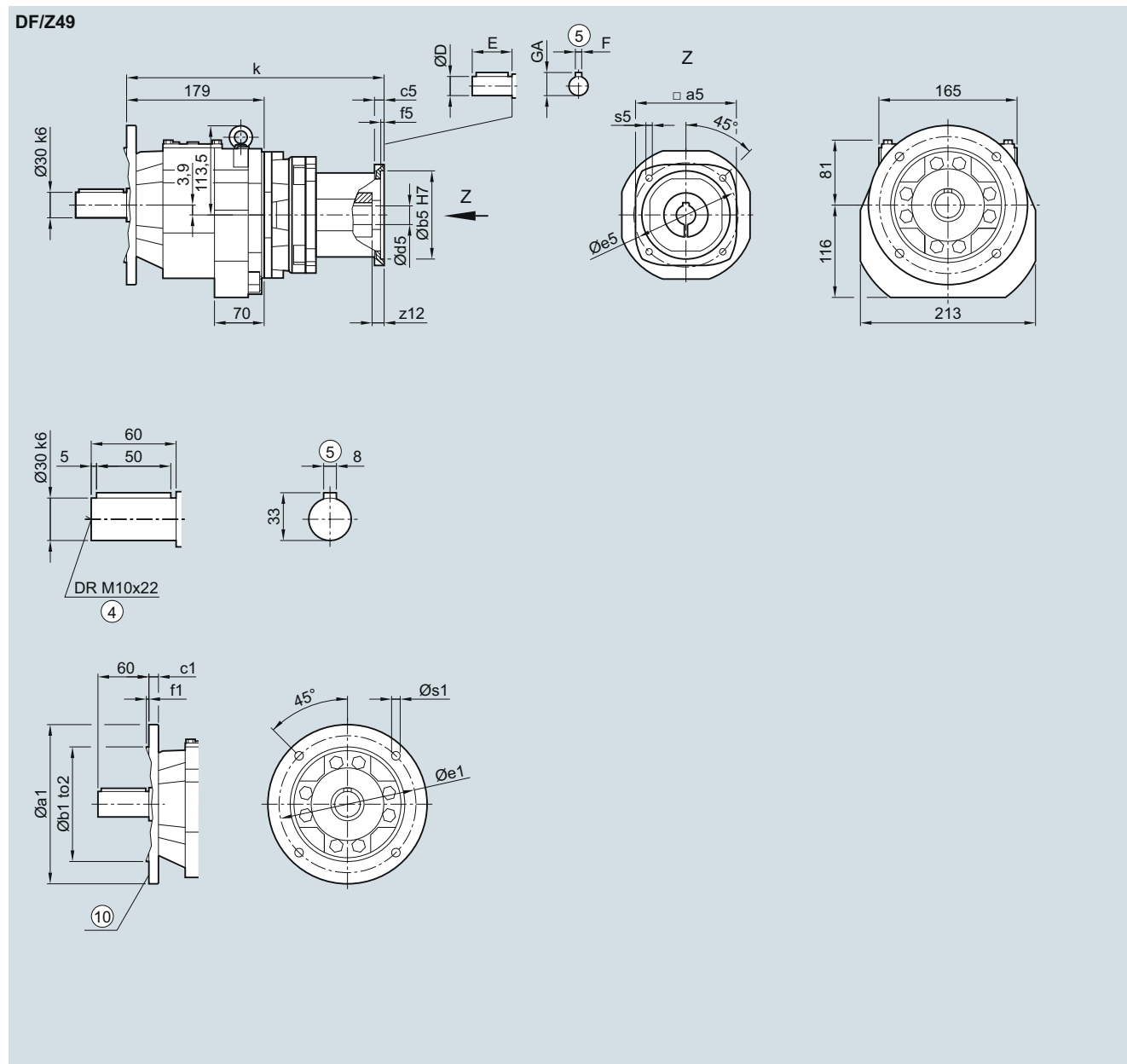

Flange	a1	b1	to2	c1	e1	f1	s1					
	140	95	j6	10	115	3.0	9.0					
	160	110	j6	10	130	3.5	9.0					
	200	130	j6	12	165	3.5	11.0					
Adapter	a5	b5	c5	f5	e5	s5	z12	d5/D	E	F	GA	k
703	71.6	60	9	4.0	75	M5	18.0	14	30	5	16.0	269.0
704	96.5	80	10	4.0	100	M6	14.0	19	40	6	21.5	316.0
706	126.0	110	12	4.5	130	M8	15.0	24	50	8	27.0	329.0
708	155.0	130	15	4.5	165	M10	23.5	32	58	10	35.0	372.5
710	192.5	180	18	5.0	215	M12	33.0	38	80	10	41.0	441.5

④ DIN 332

⑩ For inner contour, see page 3/111

⑤ Feather key/keyway DIN 6885

SIMOGEAR Gearboxes

Helical gearbox with adapter KQ

Dimensions

DZ/ZZ49 gearbox in a housing flange design

DZZ030KQ

DZ/ZZ49

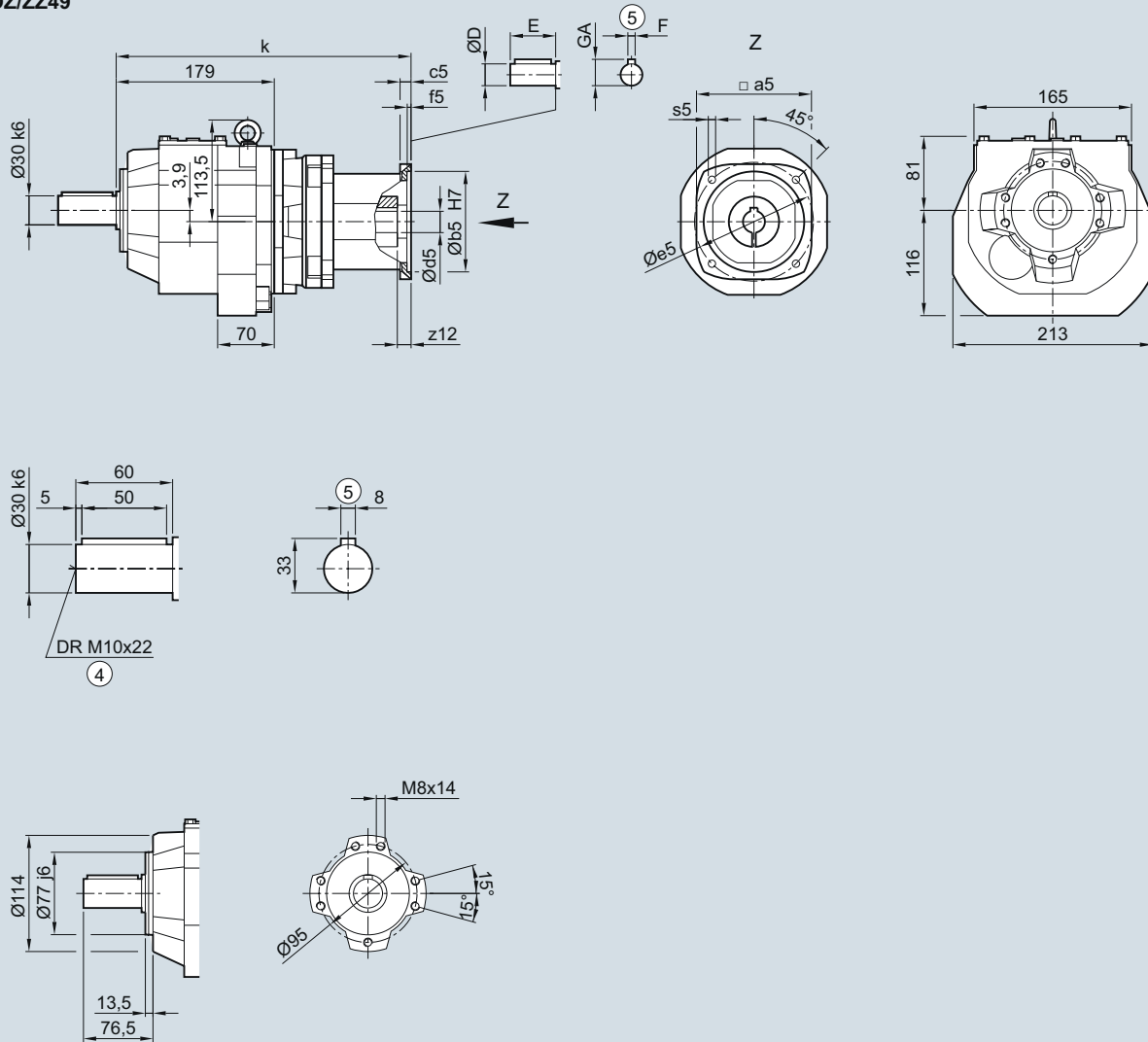

Adapter	a5	b5	c5	f5	e5	s5	z12	d5/D	E	F	GA	k
703	71.6	60	9	4.0	75	M5	18.0	14	30	5	16.0	269.0
704	96.5	80	10	4.0	100	M6	14.0	19	40	6	21.5	316.0
706	126.0	110	12	4.5	130	M8	15.0	24	50	8	27.0	329.0
708	155.0	130	15	4.5	165	M10	23.5	32	58	10	35.0	372.5
710	192.5	180	18	5.0	215	M12	33.0	38	80	10	41.0	441.5

④ DIN 332

⑤ Feather key/keyway DIN 6885

SIMOGEAR Gearboxes

Helical gearbox with adapter KQ

Dimensions

DF/ZF59 gearbox in a flange-mounted design

DZF030KQ

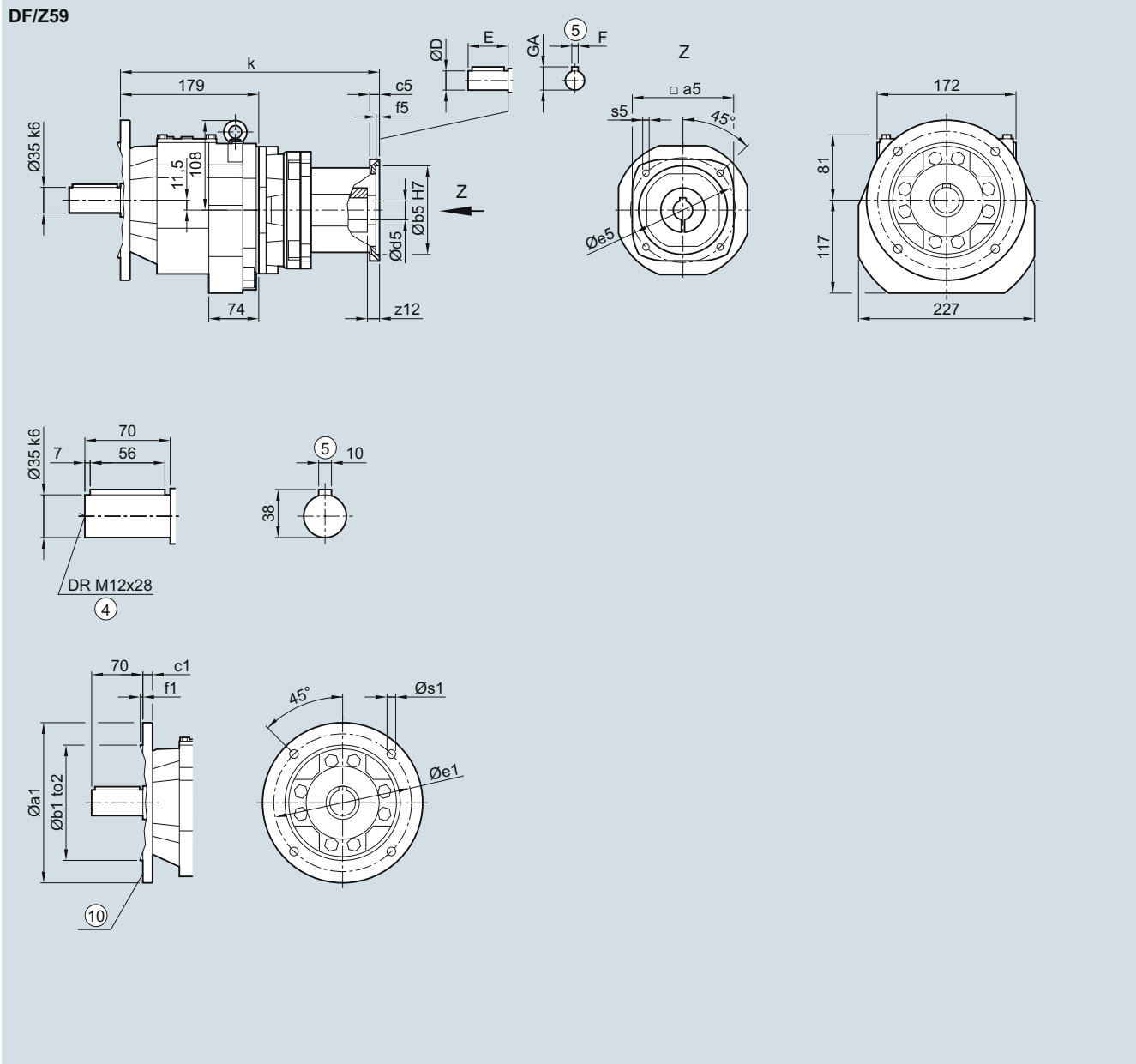

Flange	a1	b1	to2	c1	e1	f1	s1					
	160	110	j6	10	130	3.5	9.0					
	200	130	j6	12	165	3.5	11.0					
	250	180	j6	15	215	4.0	13.5					
Adapter	a5	b5	c5	f5	e5	s5	z12	d5/D	E	F	GA	k
703	71.6	60	9	4.0	75	M5	18.0	14	30	5	16.0	269.0
704	96.5	80	10	4.0	100	M6	14.0	19	40	6	21.5	316.0
706	126.0	110	12	4.5	130	M8	15.0	24	50	8	27.0	329.0
708	155.0	130	15	4.5	165	M10	23.5	32	58	10	35.0	372.5
710	192.5	180	18	5.0	215	M12	33.0	38	80	10	41.0	441.5

④ DIN 332

Ⓜ For inner contour, see page 3/111

⑤ Feather key/keyway DIN 6885

DF/ZF69 gearbox in a flange-mounted design

DZF030KQ

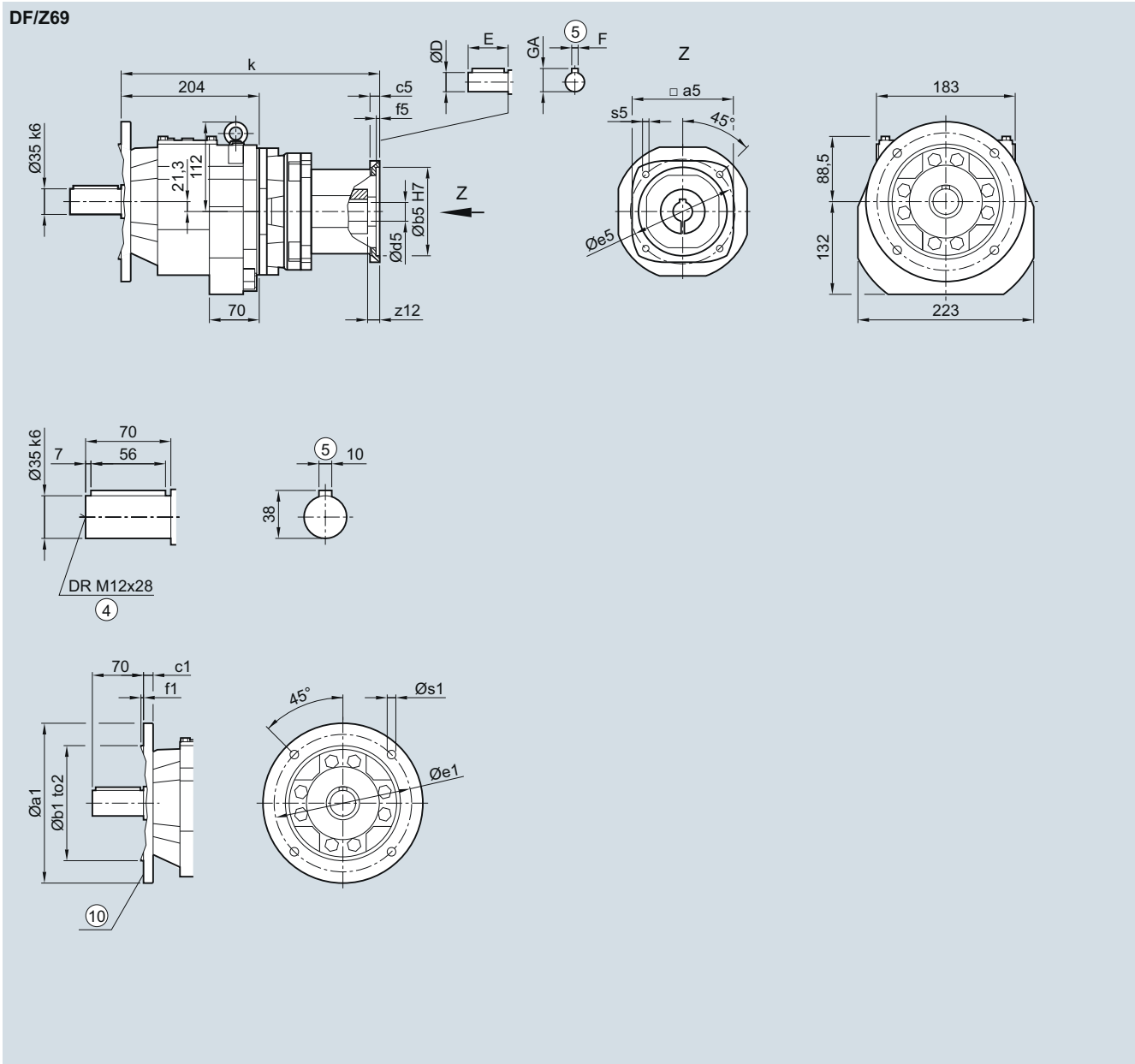

Flange	a1	b1	to2	c1	e1	f1	s1					
	200	130	j6	12	165	3.5	11.0					
	250	180	j6	15	215	4.0	13.5					
Dimensions	a5	b5	c5	f5	e5	s5	z12	d5/D	E	F	GA	k
703	71.6	60	9	4.0	75	M5	18.0	14	30	5	16.0	294.0
704	96.5	80	10	4.0	100	M6	14.0	19	40	6	21.5	341.0
706	126.0	110	12	4.5	130	M8	15.0	24	50	8	27.0	354.0
708	155.0	130	15	4.5	165	M10	23.5	32	58	10	35.0	397.5
710	192.5	180	18	5.0	215	M12	33.0	38	80	10	41.0	466.5

④ DIN 332

Ⓜ For inner contour, see page 3/111

⑤ Feather key/keyway DIN 6885

D/Z79 and DB/ZB79 gearboxes in a foot and foot/flange-mounted design

DZ030, DZB030KQ

D/Z79

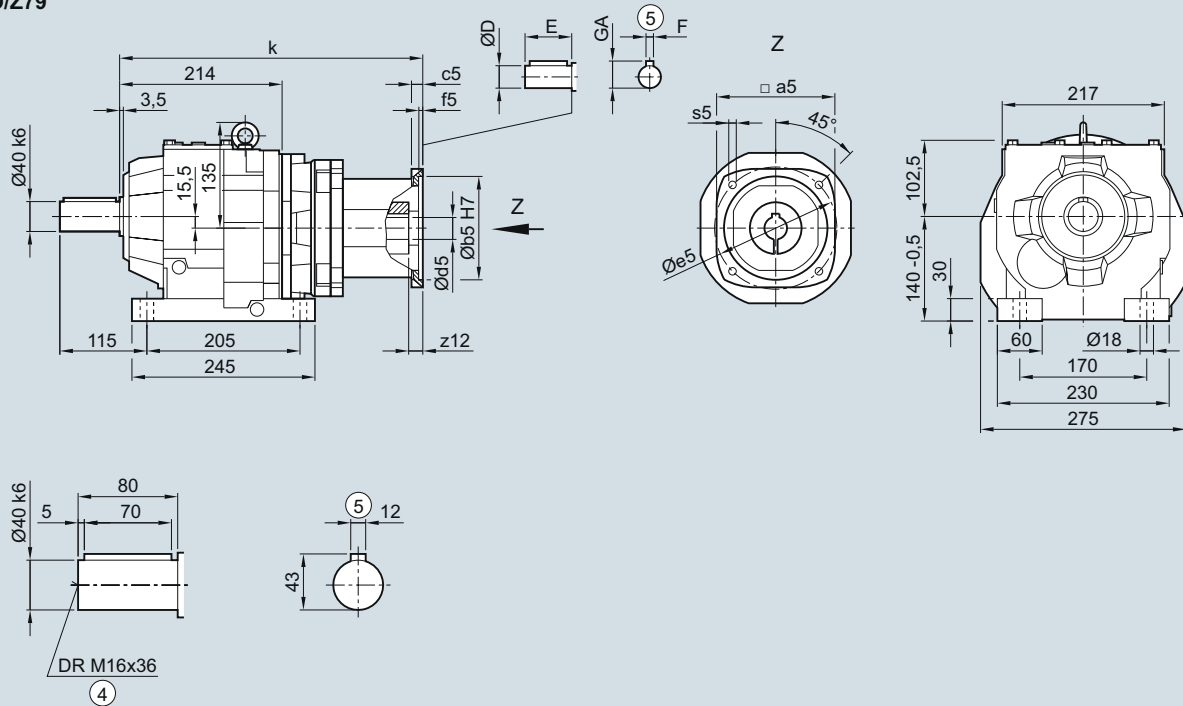

DB/ZB79

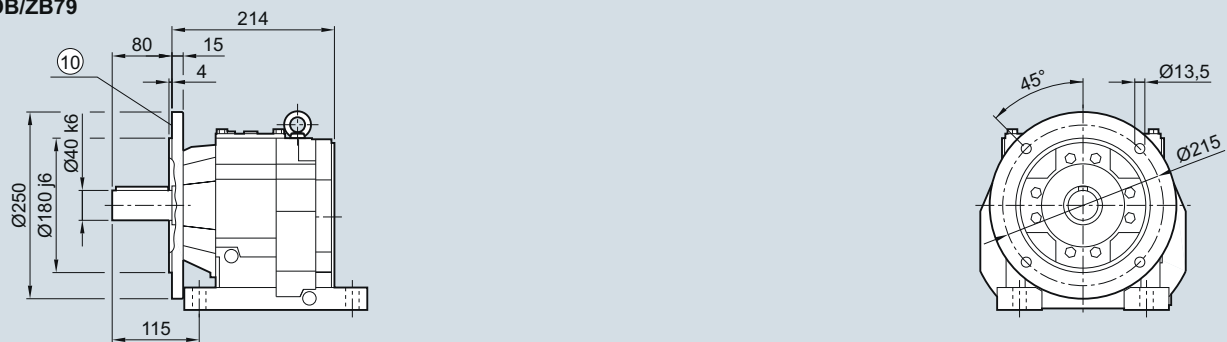

Adapter	a5	b5	c5	f5	e5	s5	z12	d5/D	E	F	GA	k
703	71.6	60	9	4.0	75	M5	18.0	14	30	5	16.0	302.0
704	96.5	80	10	4.0	100	M6	14.0	19	40	6	21.5	345.0
706	126.0	110	12	4.5	130	M8	15.0	24	50	8	27.0	358.0
708	155.0	130	15	4.5	165	M10	23.5	32	58	10	35.0	401.5
710	192.5	180	18	5.0	215	M12	33.0	38	80	10	41.0	470.5

④ DIN 332

Ⓜ For inner contour, see page 3/111

⑤ Feather key/keyway DIN 6885

SIMOGEAR Gearboxes

Helical gearbox with adapter KQ

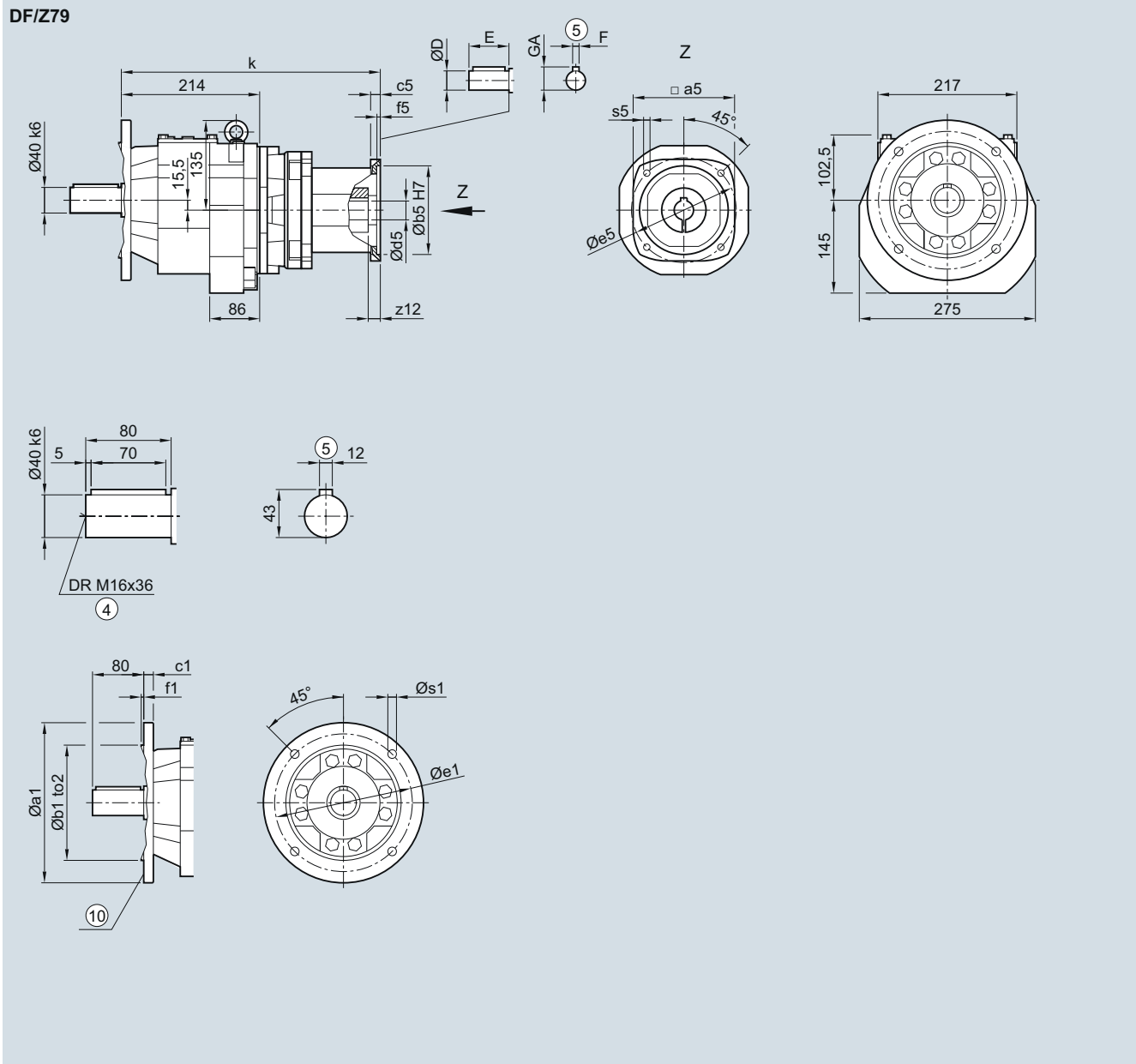
Dimensions**DF/ZF79 gearbox in a flange-mounted design****DZF030KQ**

Flange	a1	b1	to2	c1	e1	f1	s1					
	250	180	j6	15	215	4.0	13.5					
	300	230	j6	16	265	4.0	13.5					
Adapter	a5	b5	c5	f5	e5	s5	z12	d5/D	E	F	GA	k
703	71.6	60	9	4.0	75	M5	18.0	14	30	5	16.0	302.0
704	96.5	80	10	4.0	100	M6	14.0	19	40	6	21.5	345.0
706	126.0	110	12	4.5	130	M8	15.0	24	50	8	27.0	358.0
708	155.0	130	15	4.5	165	M10	23.5	32	58	10	35.0	401.5
710	192.5	180	18	5.0	215	M12	33.0	38	80	10	41.0	470.5

④ DIN 332

Ⓜ For inner contour, see page 3/111

⑤ Feather key/keyway DIN 6885

DZ/ZZ79 gearbox in a housing flange design

DZZ030KQ

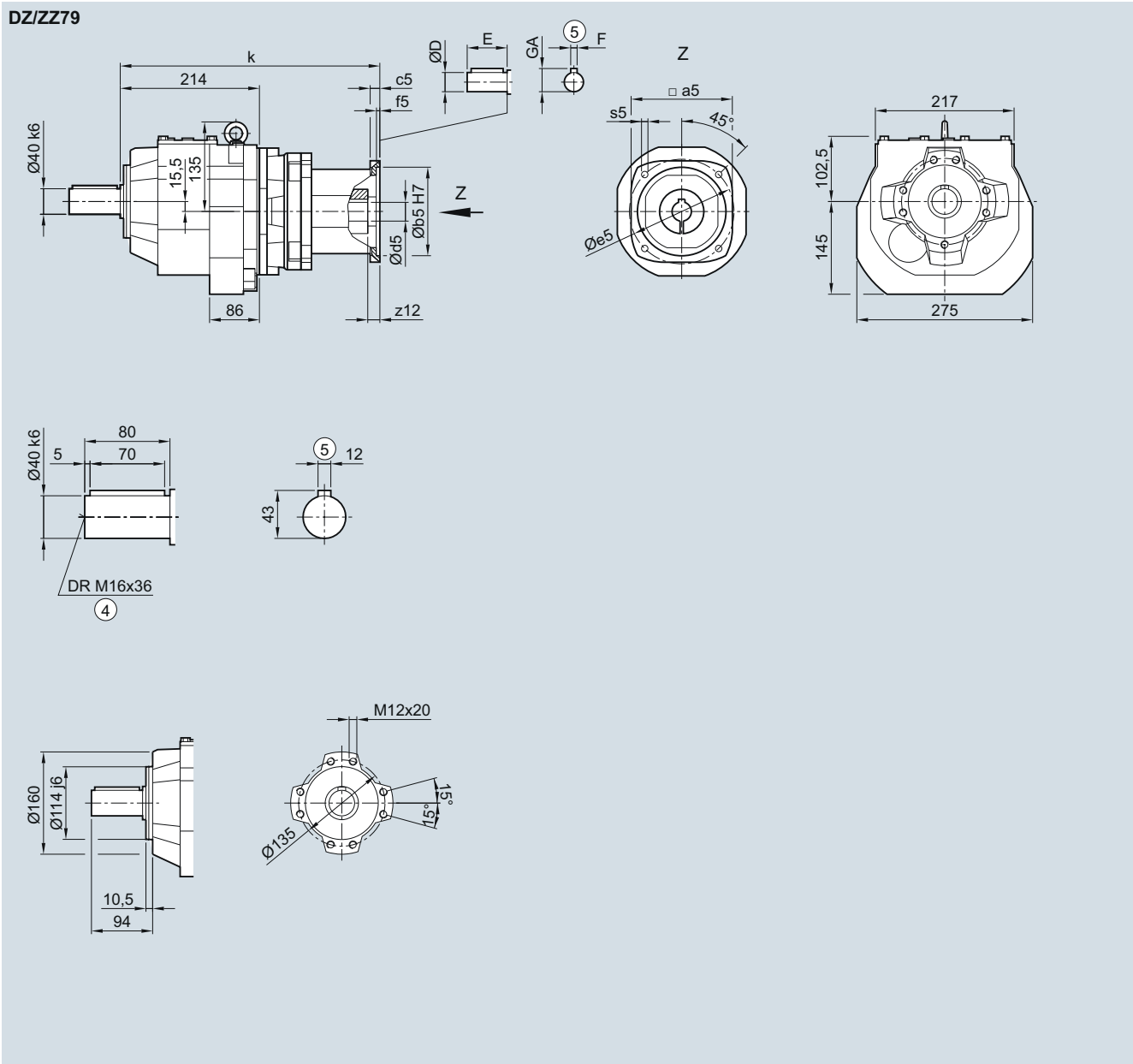

3

Adapter	a5	b5	c5	f5	e5	s5	z12	d5/D	E	F	GA	k
703	71.6	60	9	4.0	75	M5	18.0	14	30	5	16.0	302.0
704	96.5	80	10	4.0	100	M6	14.0	19	40	6	21.5	345.0
706	126.0	110	12	4.5	130	M8	15.0	24	50	8	27.0	358.0
708	155.0	130	15	4.5	165	M10	23.5	32	58	10	35.0	401.5
710	192.5	180	18	5.0	215	M12	33.0	38	80	10	41.0	470.5

④ DIN 332

⑤ Feather key/keyway DIN 6885

SIMOGEAR Gearboxes

Helical gearbox with adapter KQ

Dimensions

D/Z89 and DB/ZB89 gearboxes in a foot and foot/flange-mounted design

DZ030, DZB030KQ

D/Z89

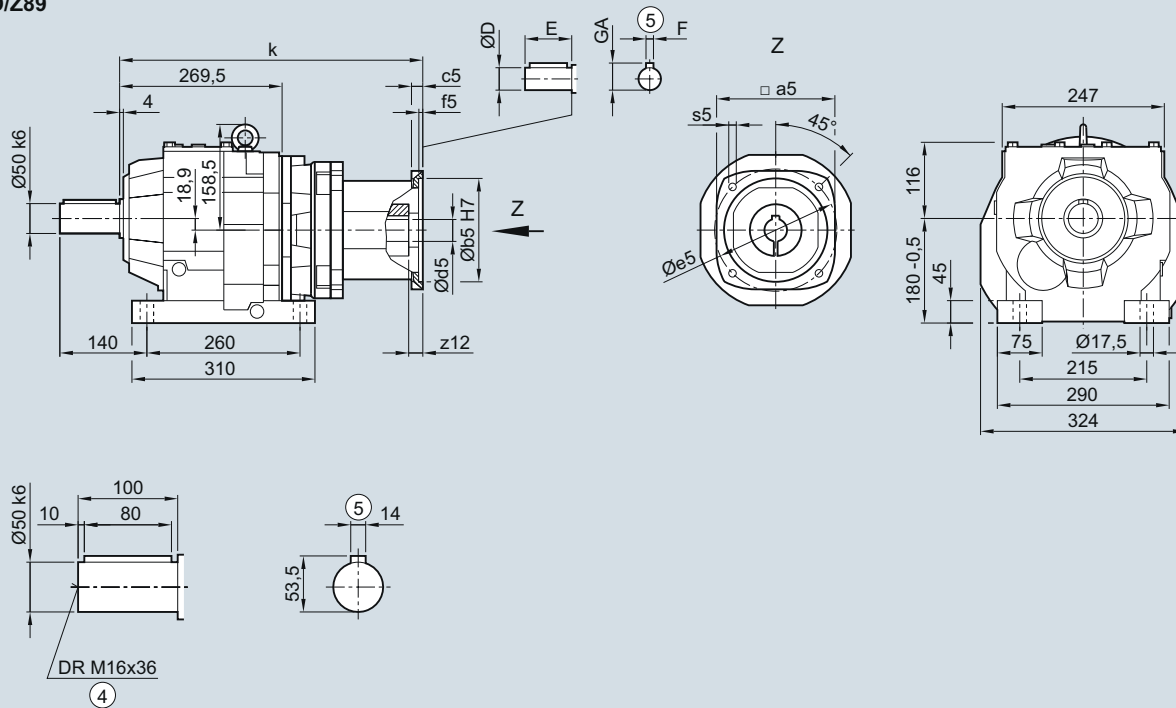

DB/ZB89

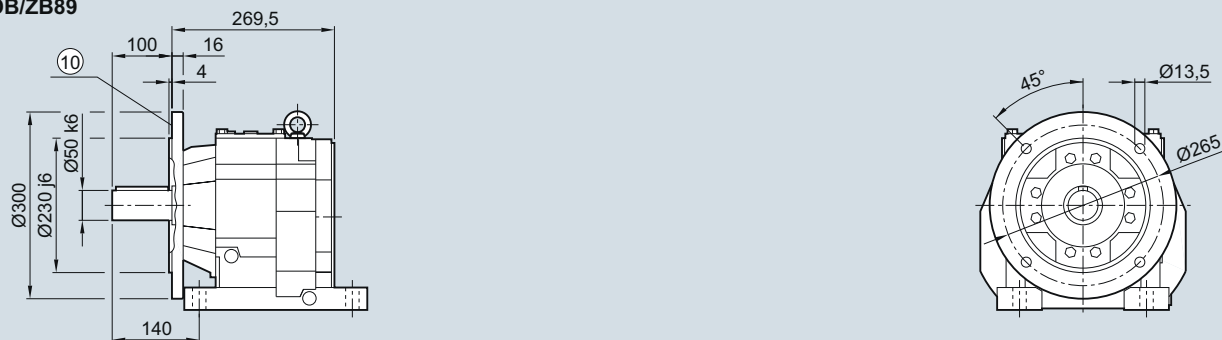

Adapter	a5	b5	c5	f5	e5	s5	z12	d5/D	E	F	GA	k
704	96.5	80	10	4.0	100	M6	14.0	19	40	6	21.5	387.5
706	126.0	110	12	4.5	130	M8	15.0	24	50	8	27.0	400.5
708	155.0	130	15	4.5	165	M10	23.5	32	58	10	35.0	440.0
710	192.5	180	18	5.0	215	M12	33.0	38	80	10	41.0	509.0

④ DIN 332

Ⓜ For inner contour, see page 3/111

⑤ Feather key/keyway DIN 6885

DF/ZF89 gearbox in a flange-mounted design

DZF030KQ

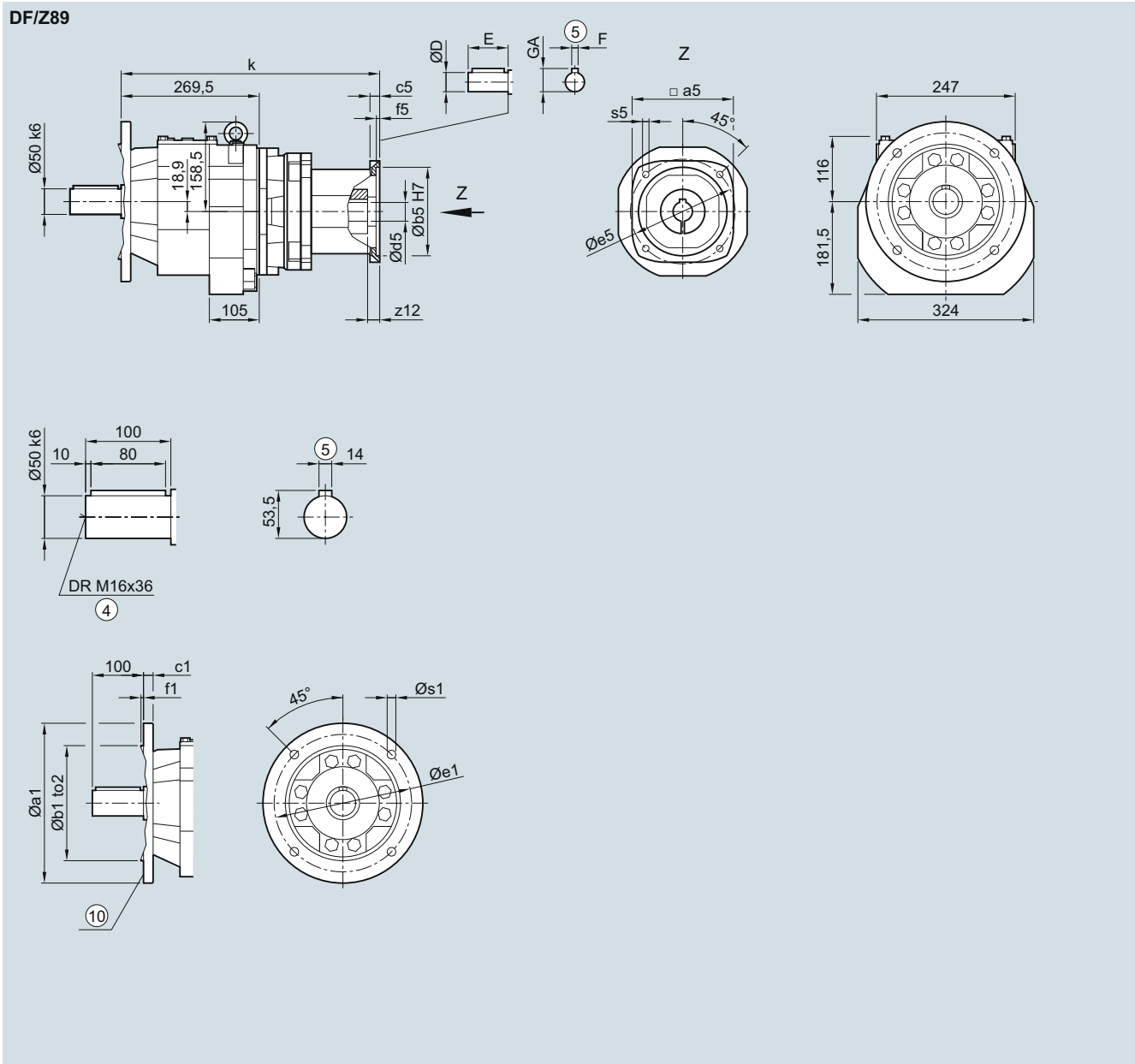

Flange	a1	b1	to2	c1	e1	f1	s1					
	300	230	j6	16	265	4.0	13.5					
	350	250	j6	18	300	5.0	17.5					
Adapter	a5	b5	c5	f5	e5	s5	z12	d5/D	E	F	GA	k
704	96.5	80	10	4.0	100	M6	14.0	19	40	6	21.5	387.5
706	126.0	110	12	4.5	130	M8	15.0	24	50	8	27.0	400.5
708	155.0	130	15	4.5	165	M10	23.5	32	58	10	35.0	440.0
710	192.5	180	18	5.0	215	M12	33.0	38	80	10	41.0	509.0

(4) DIN 332

(5) Feather key/keyway DIN 6885

(10) For inner contour, see page 3/111

SIMOGEAR Gearboxes

Helical gearbox with adapter KQ

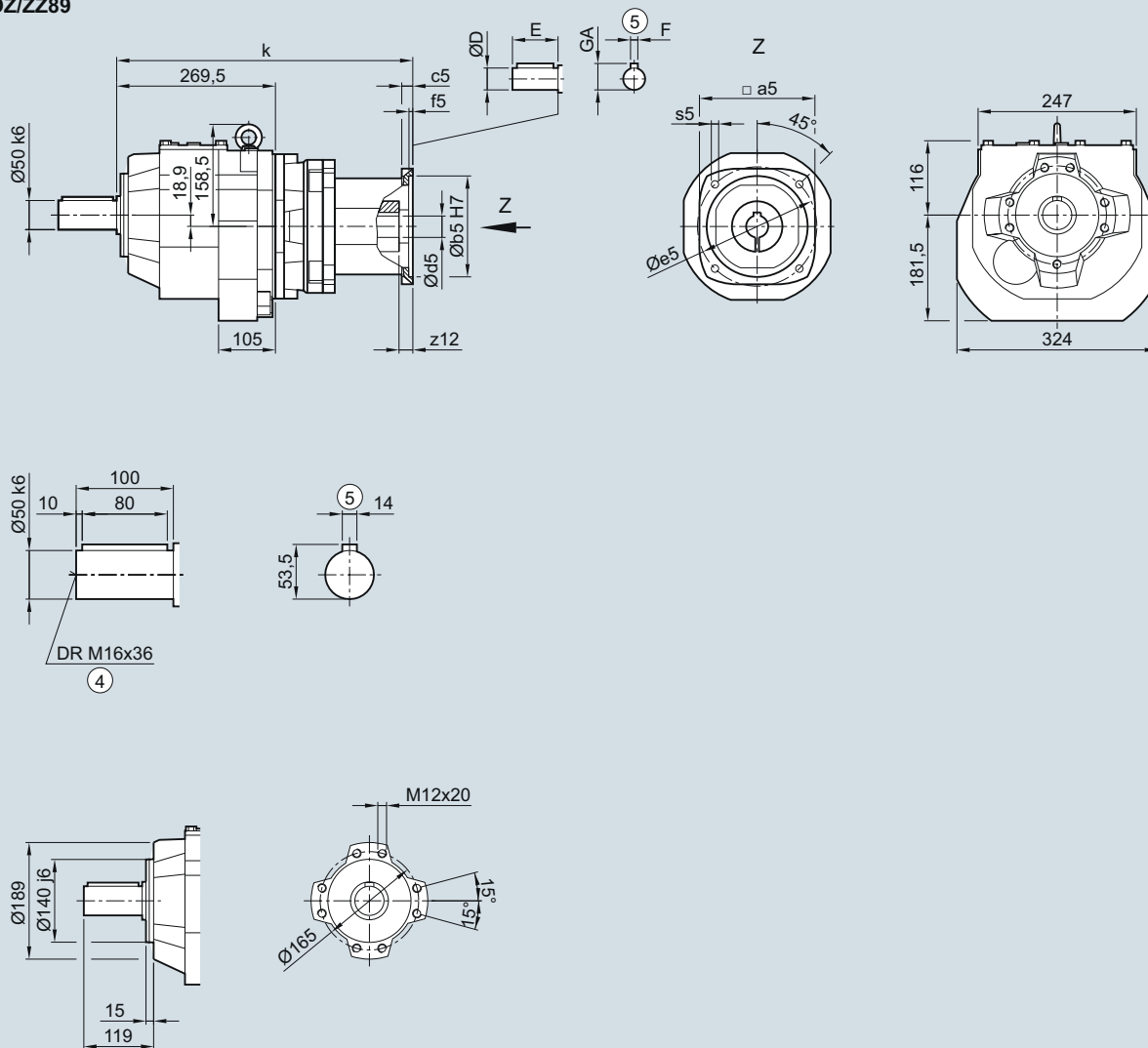
Dimensions**DZ/ZZ89 gearbox in a housing flange design****DZZ030KQ****DZ/ZZ89**

Adapter	a5	b5	c5	f5	e5	s5	z12	d5/D	E	F	GA	k
704	96.5	80	10	4.0	100	M6	14.0	19	40	6	21.5	387.5
706	126.0	110	12	4.5	130	M8	15.0	24	50	8	27.0	400.5
708	155.0	130	15	4.5	165	M10	23.5	32	58	10	35.0	440.0
710	192.5	180	18	5.0	215	M12	33.0	38	80	10	41.0	509.0

④ DIN 332

⑤ Feather key/keyway DIN 6885

D/Z109 gearbox in a foot-mounted design

DZ030KQ

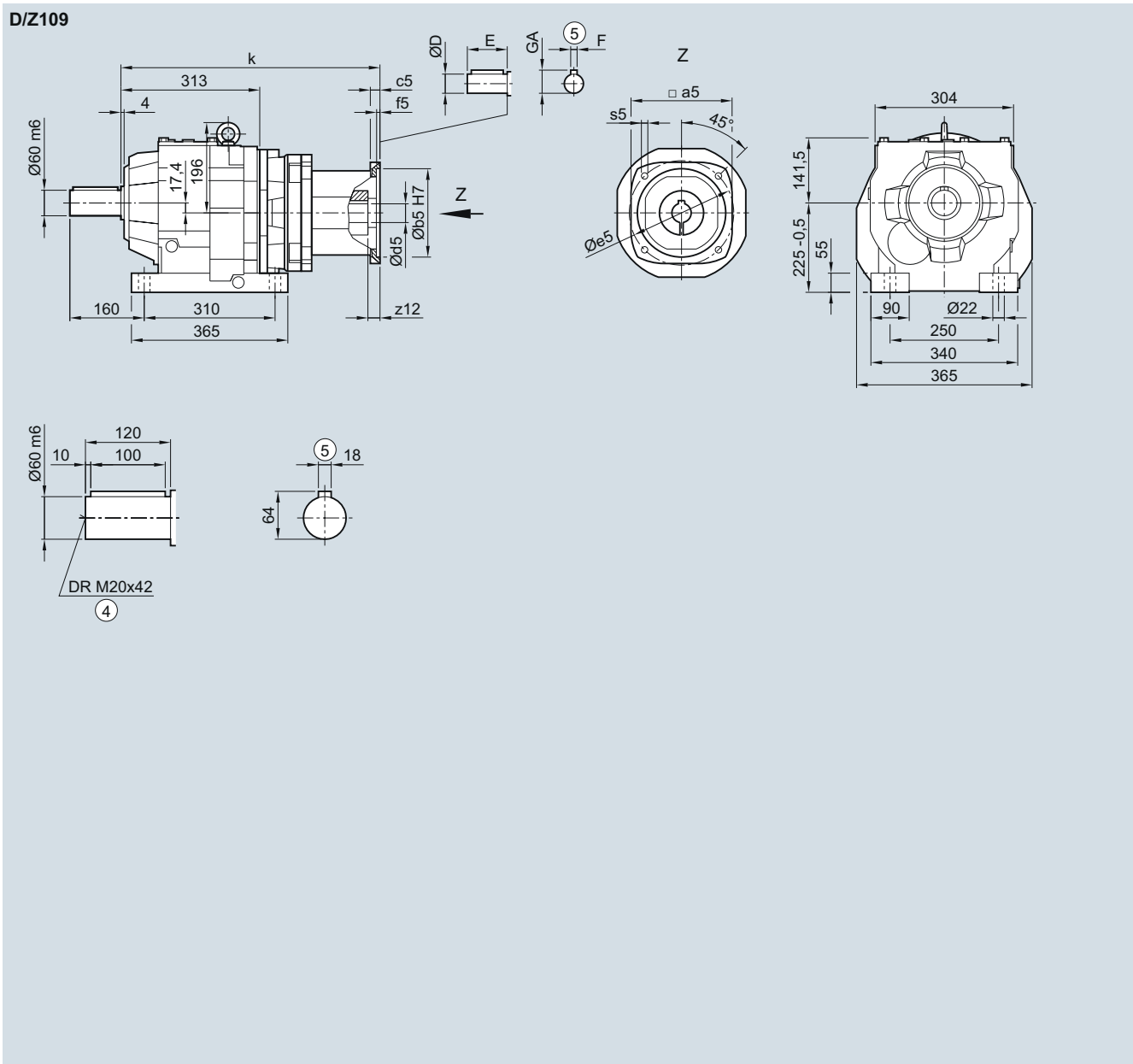

Adapter	a5	b5	c5	f5	e5	s5	z12	d5/D	E	F	GA	k
706	126.0	110	12	4.5	130	M8	15.0	24	50	8	27.0	437.0
708	155.0	130	15	4.5	165	M10	23.5	32	58	10	35.0	474.5
710	192.5	180	18	5.0	215	M12	33.0	38	80	10	41.0	543.5

④ DIN 332

⑤ Feather key/keyway DIN 6885

SIMOGEAR Gearboxes

Helical gearbox with adapter KQ

Dimensions

DF/ZF109 gearbox in a flange-mounted design

DZF030KQ

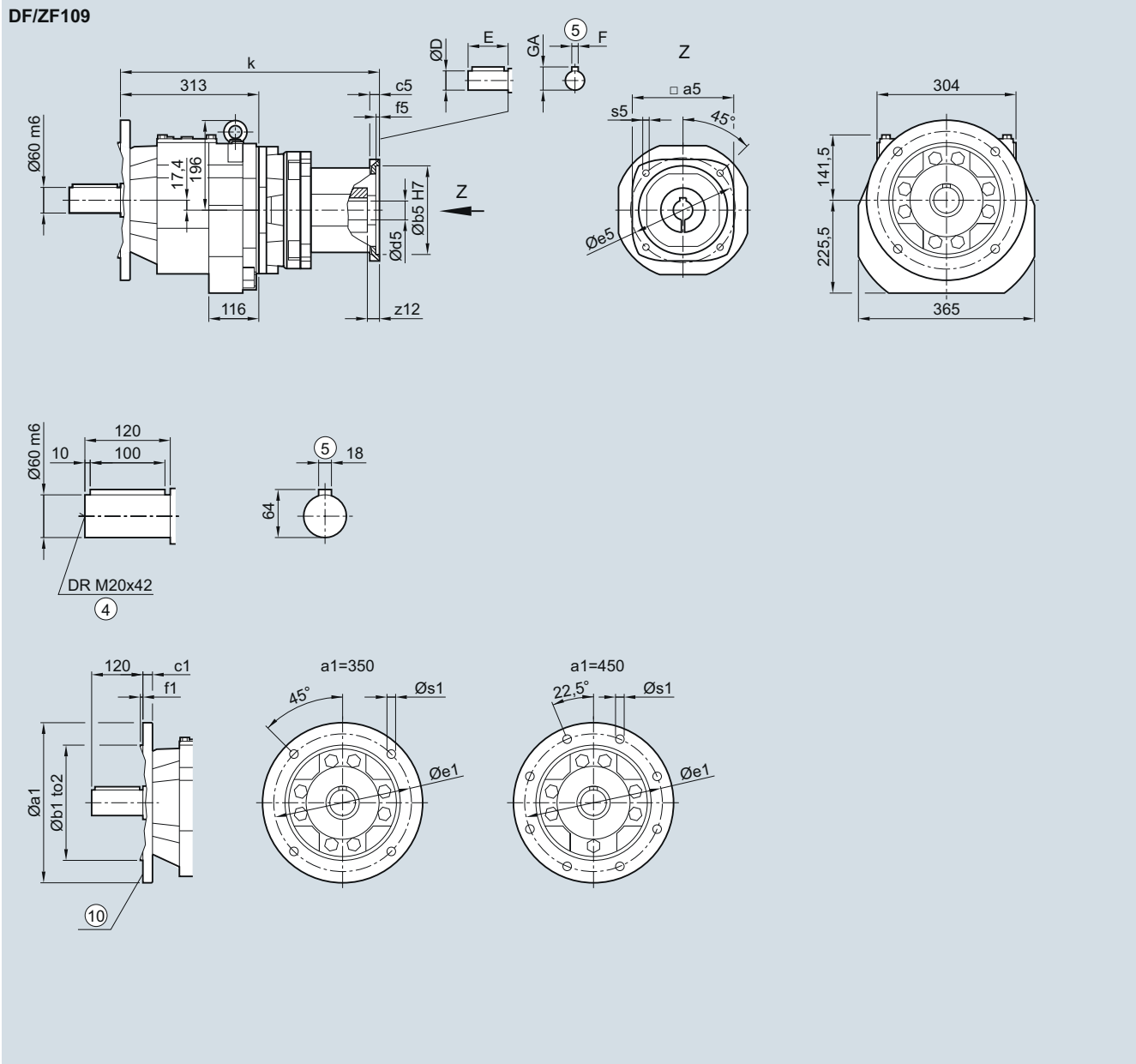

Flange	a1	b1	to2	c1	e1	f1	s1					
	350	250	h6	18	300	5	17.5					
	450	350	h6	22	400	5	17.5					
Adapter	a5	b5	c5	f5	e5	s5	z12	d5/D	E	F	GA	k
706	126.0	110	12	4.5	130	M8	15.0	24	50	8	27.0	437.0
708	155.0	130	15	4.5	165	M10	23.5	32	58	10	35.0	474.5
710	192.5	180	18	5.0	215	M12	33.0	38	80	10	41.0	543.5

④ DIN 332

Ⓜ For inner contour, see page 3/111

⑤ Feather key/keyway DIN 6885

DZ/ZZ109 gearbox in a housing flange design

DZZ030KQ

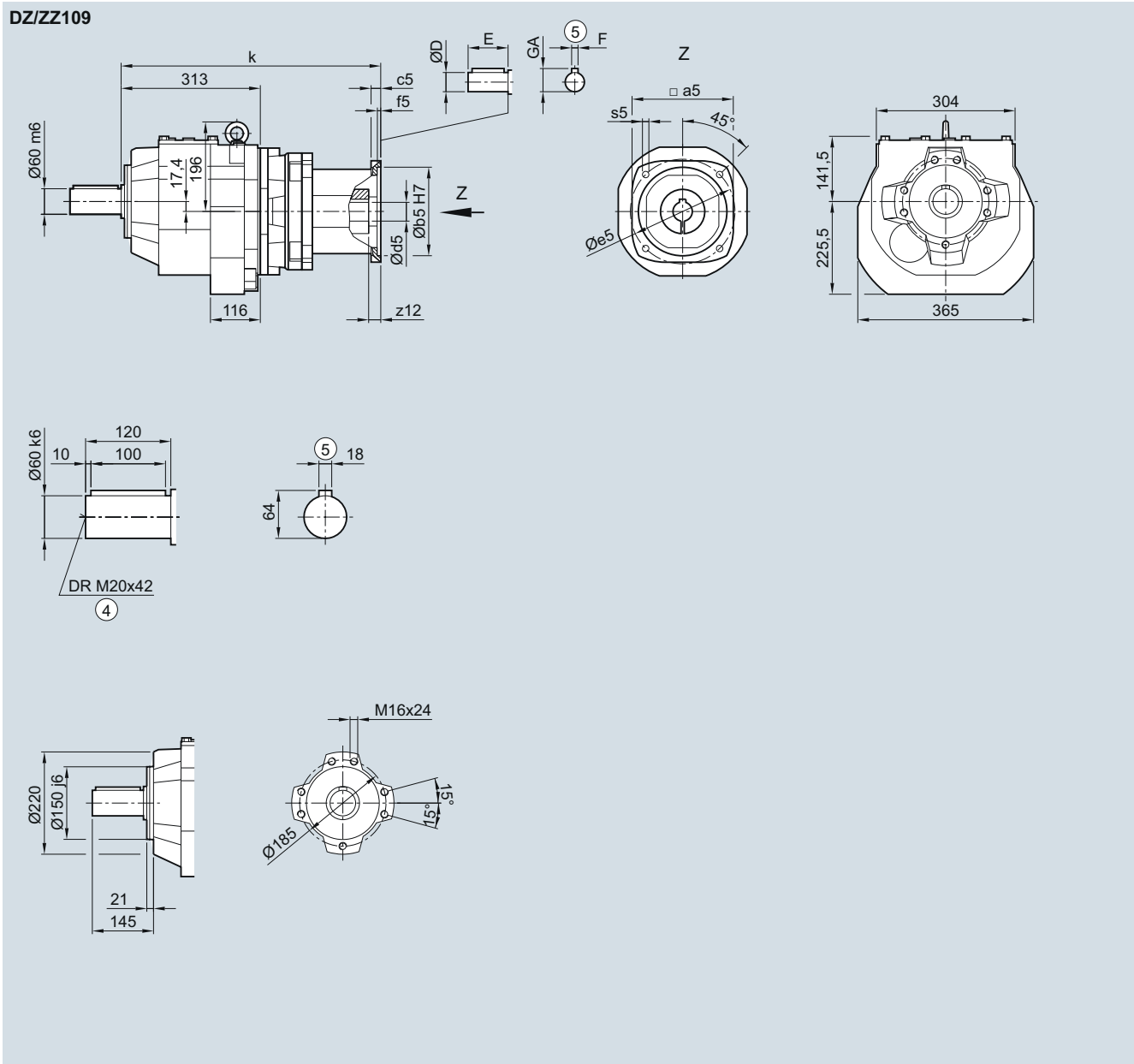

Adapter	a5	b5	c5	f5	e5	s5	z12	d5/D	E	F	GA	k
706	126.0	110	12	4.5	130	M8	15.0	24	50	8	27.0	437.0
708	155.0	130	15	4.5	165	M10	23.5	32	58	10	35.0	474.5
710	192.5	180	18	5.0	215	M12	33.0	38	80	10	41.0	543.5

④ DIN 332

⑤ Feather key/keyway DIN 6885

SIMOGEAR Gearboxes

Helical gearbox with adapter KQ

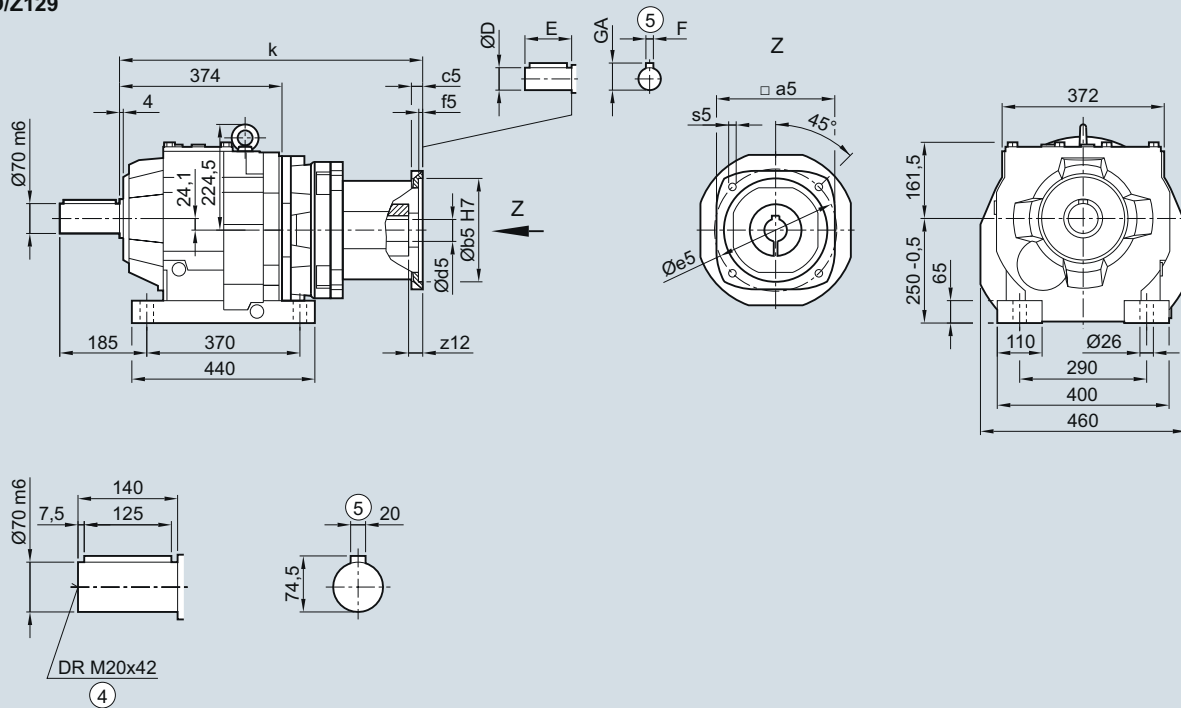
Dimensions**D/Z129 gearbox in a foot-mounted design****DZ030KQ****D/Z129**

Adapter	a5	b5	c5	f5	e5	s5	z12	d5/D	E	F	GA	k
706	126.0	110	12	4.5	130	M8	15.0	24	50	8	27.0	491.0
708	155.0	130	15	4.5	165	M10	23.5	32	58	10	35.0	526.5
710	192.5	180	18	5.0	215	M12	33.0	38	80	10	41.0	593.5

④ DIN 332

⑤ Feather key/keyway DIN 6885

DF/ZF129 gearbox in a flange-mounted design

DZF030KQ

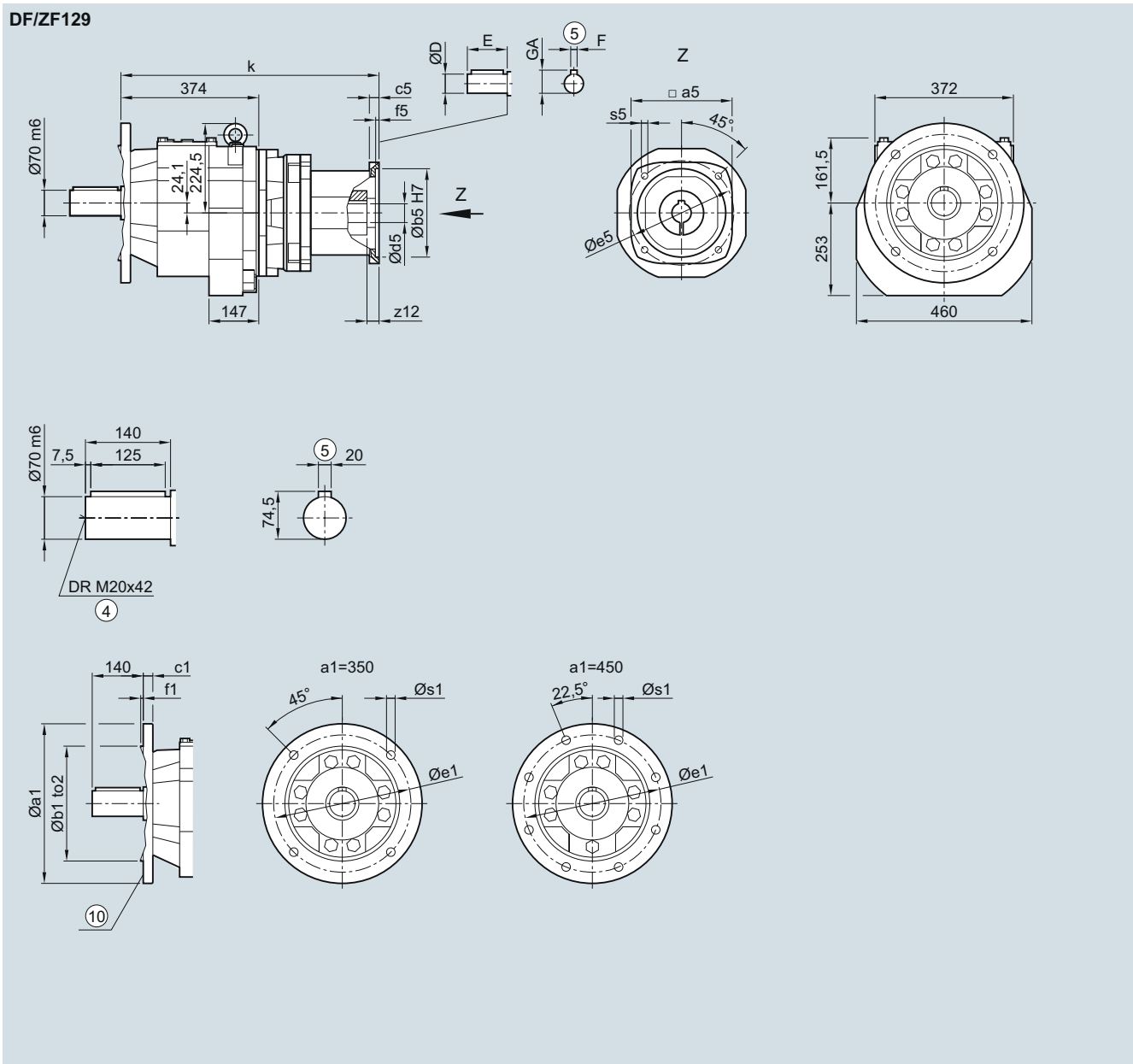

Flange	a1	b1	to2	c1	e1	f1	s1					
	350	250	h6	20	300	5	17.5					
	450	350	h6	22	400	5	17.5					
Adapter	a5	b5	c5	f5	e5	s5	z12	d5/D	E	F	GA	k
706	126.0	110	12	4.5	130	M8	15.0	24	50	8	27.0	491.0
708	155.0	130	15	4.5	165	M10	23.5	32	58	10	35.0	526.5
710	192.5	180	18	5.0	215	M12	33.0	38	80	10	41.0	593.5

④ DIN 332

Ⓜ For inner contour, see page 3/111

⑤ Feather key/keyway DIN 6885

SIMOGEAR Gearboxes

Helical gearbox with adapter KQ

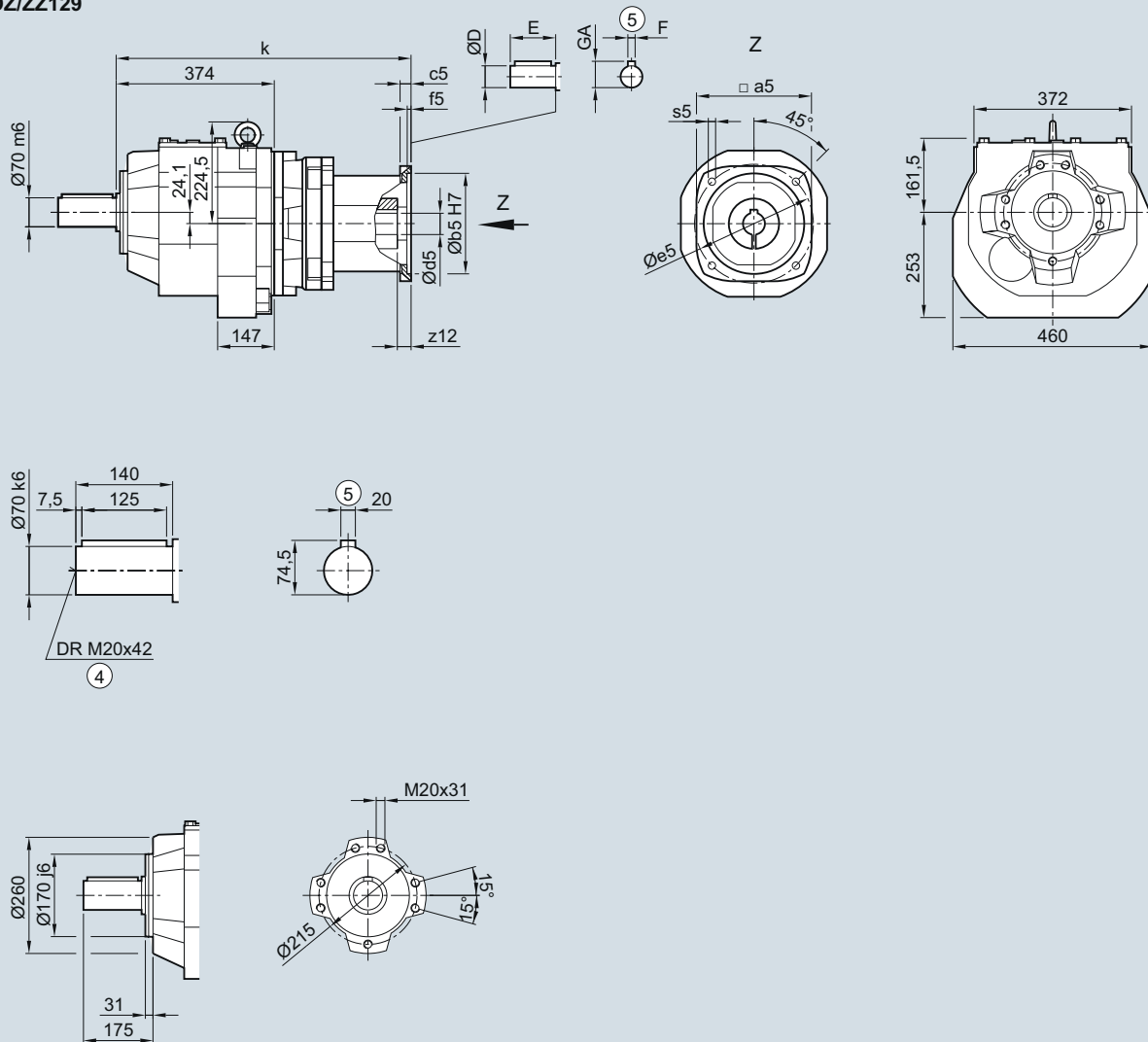
Dimensions**DZ/ZZ129 gearbox in a housing flange design****DZZ030KQ****DZ/ZZ129**

Adapter	a5	b5	c5	f5	e5	s5	z12	d5/D	E	F	GA	k
706	126.0	110	12	4.5	130	M8	15.0	24	50	8	27.0	491.0
708	155.0	130	15	4.5	165	M10	23.5	32	58	10	35.0	526.5
710	192.5	180	18	5.0	215	M12	33.0	38	80	10	41.0	593.5

④ DIN 332

⑤ Feather key/keyway DIN 6885

D/Z149 gearbox in a foot-mounted design

DZ030KQ

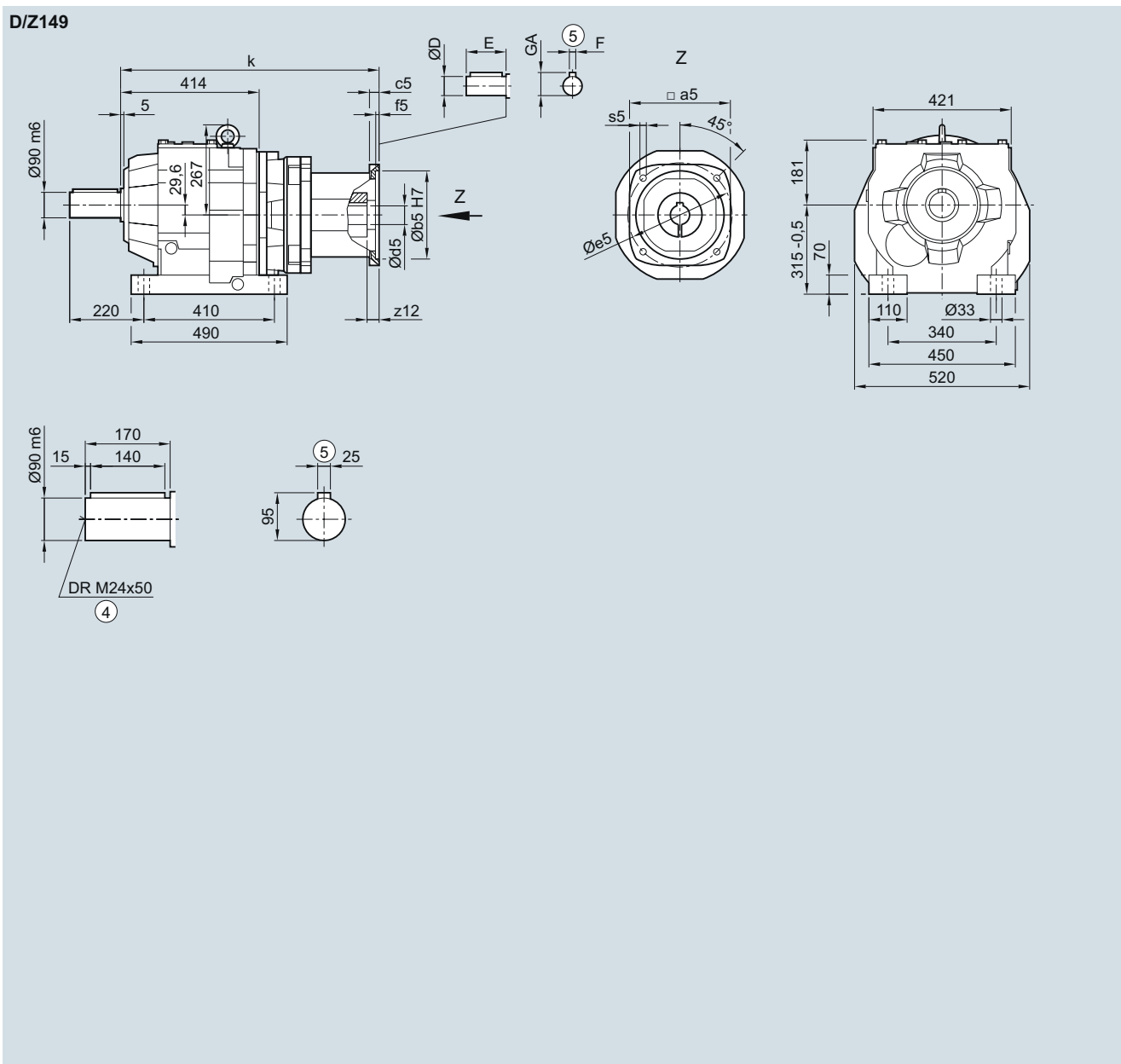

Adapter	a5	b5	c5	f5	e5	s5	z12	d5/D	E	F	GA	k
708	155.0	130	15	4.5	165	M10	23.5	32	58	10	35.0	565.0
710	192.5	180	18	5.0	215	M12	33.0	38	80	10	41.0	627.0

④ DIN 332

⑤ Feather key/keyway DIN 6885

SIMOGEAR Gearboxes

Helical gearbox with adapter KQ

Dimensions

DF/ZF149 gearbox in a flange-mounted design

DZF030KQ

DF/ZF149

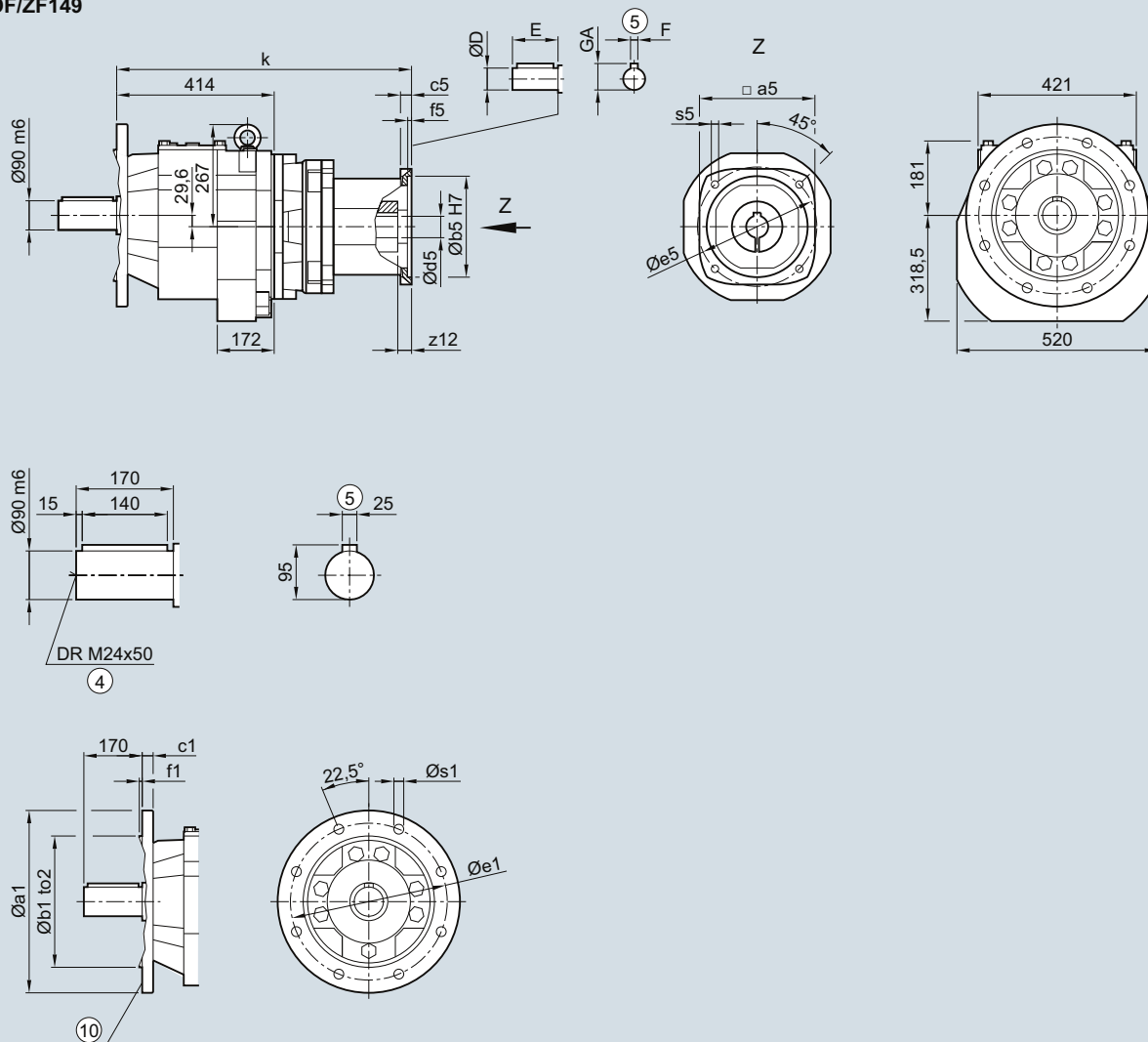

Flange	a1	b1	to2	c1	e1	f1	s1					
	450	350	h6	22	400	5	17.5					
	550	450	h6	25	500	5	17.5					
Adapter	a5	b5	c5	f5	e5	s5	z12	d5/D	E	F	GA	k
708	155.0	130	15	4.5	165	M10	23.5	32	58	10	35.0	526.5
710	192.5	180	18	5.0	215	M12	33.0	38	80	10	41.0	593.5

④ DIN 332

Ⓜ For inner contour, see page 3/111

⑤ Feather key/keyway DIN 6885

D/Z169 gearbox in a foot-mounted design

DZ030KQ

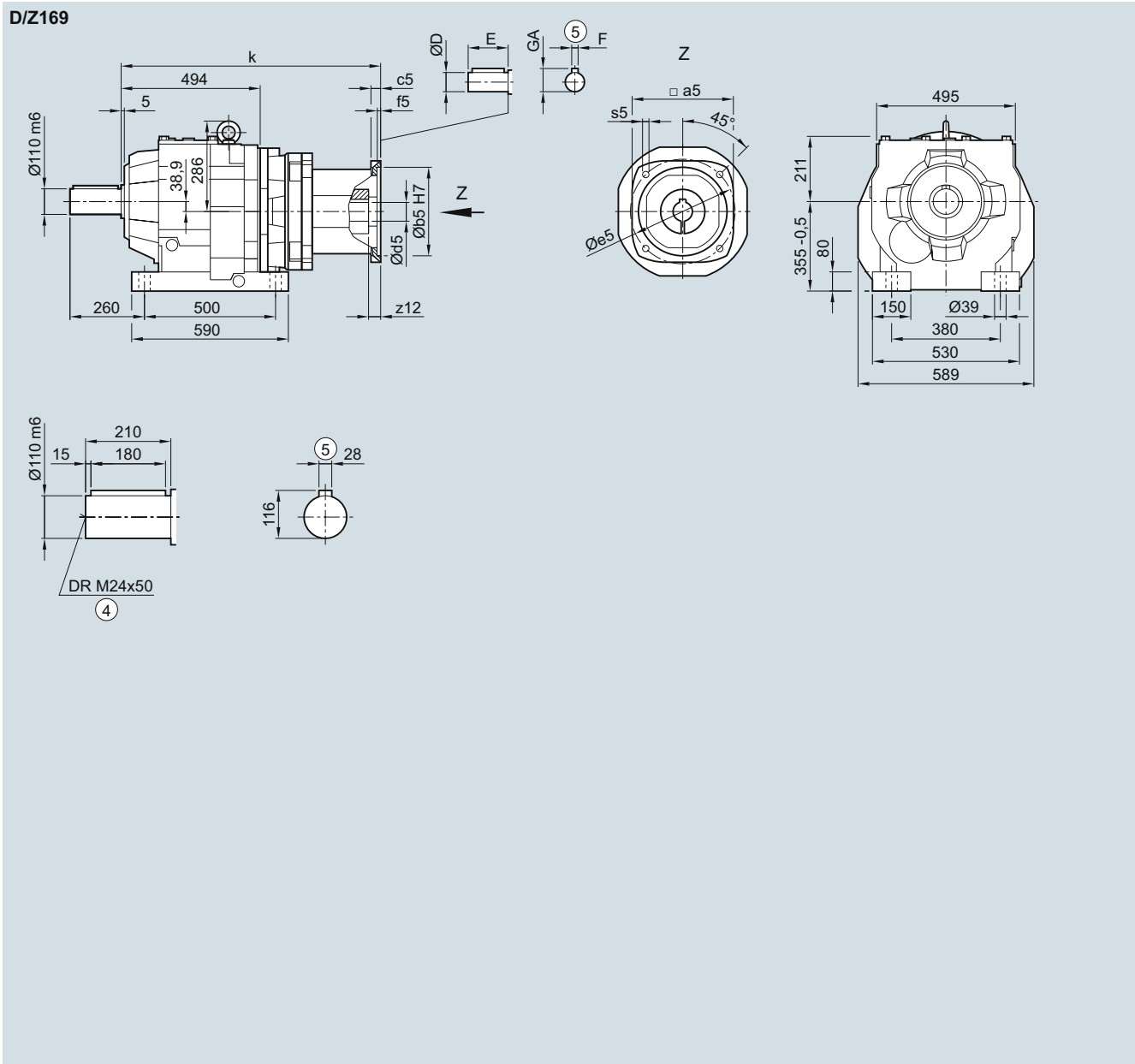

Adapter	a5	b5	c5	f5	e5	s5	z12	d5/D	E	F	GA	k
708	155.0	130	15	4.5	165	M10	23.5	32	58	10	35.0	632.5
710	192.5	180	18	5.0	215	M12	33.0	38	80	10	41.0	694.0

④ DIN 332

⑤ Feather key/keyway DIN 6885

SIMOGEAR Gearboxes

Helical gearbox with adapter KQ

Dimensions

DF/ZF169 gearbox in a flange-mounted design

DZF030KQ

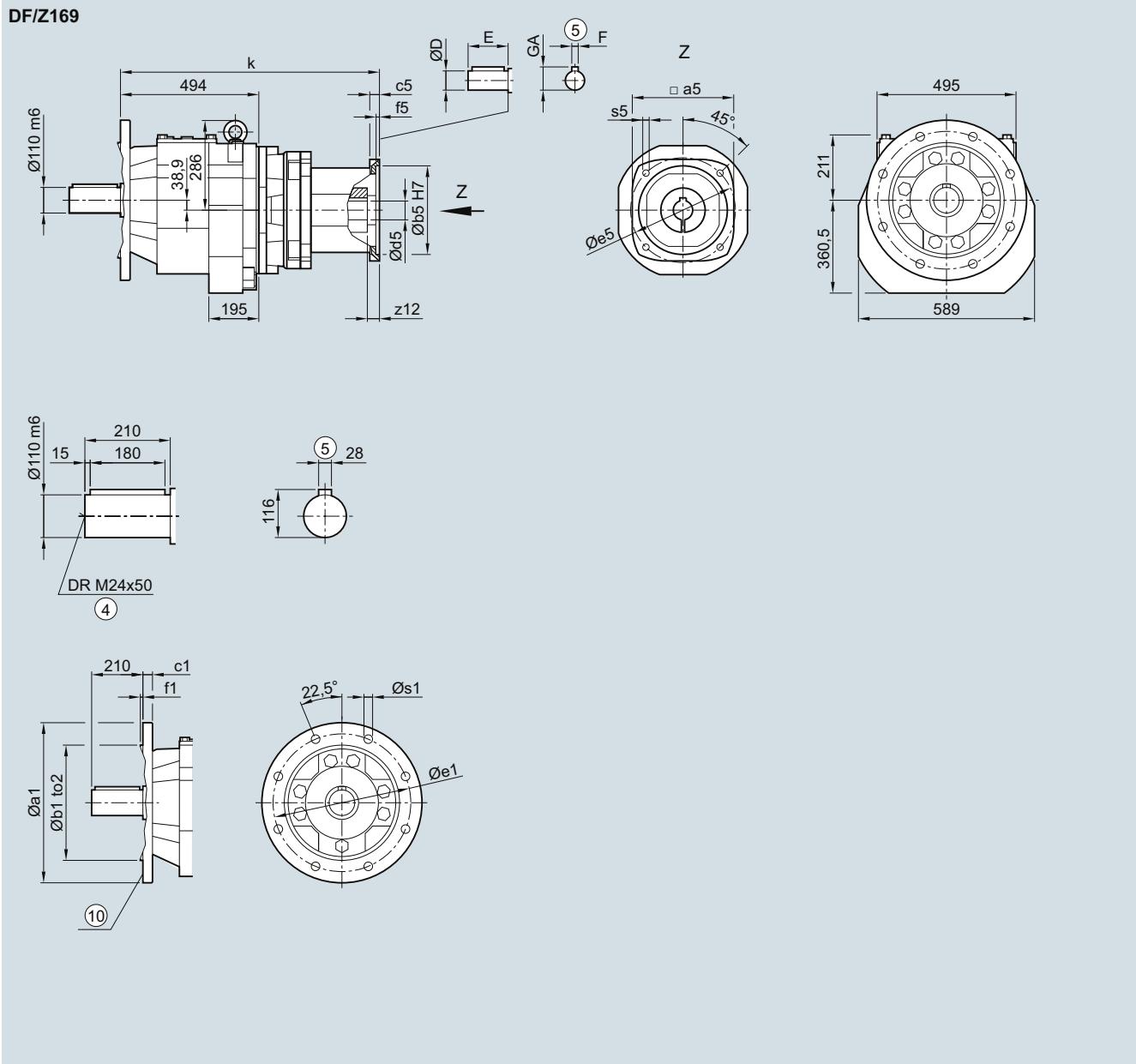

Flange	a1	b1	to2	c1	e1	f1	s1					
	450	350	h6	22	400	5	17.5					
	550	450	h6	25	500	5	17.5					
Adapter	a5	b5	c5	f5	e5	s5	z12	d5/D	E	F	GA	k
708	155.0	130	15	4.5	165	M10	23.5	32	58	10	35.0	632.5
710	192.5	180	18	5.0	215	M12	33.0	38	80	10	41.0	694.0

④ DIN 332

Ⓜ For inner contour, see page 3/111

⑤ Feather key/keyway DIN 6885

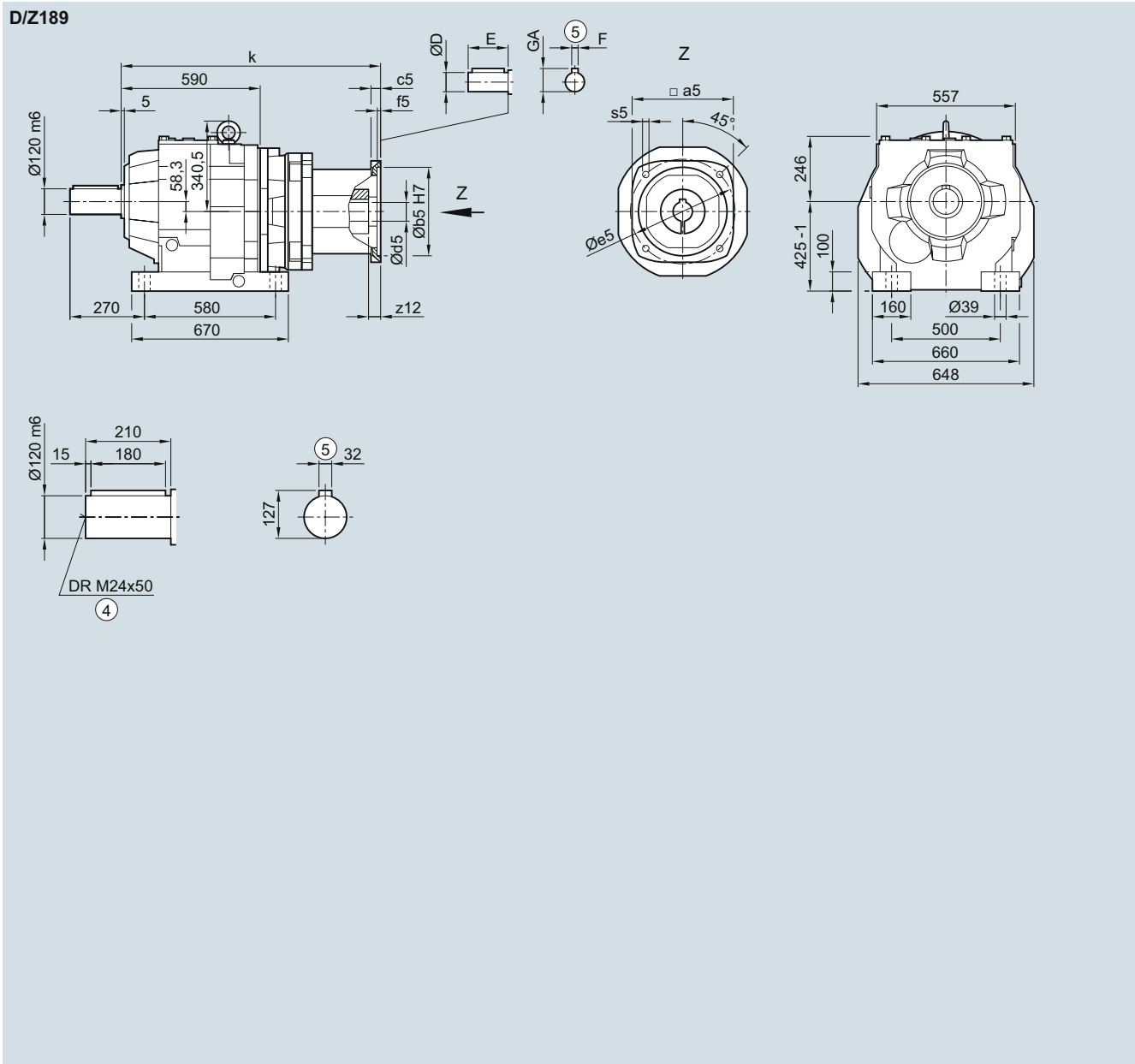
D/Z189 gearbox in a foot-mounted design
DZ030KQ

Adapter	a5	b5	c5	f5	e5	s5	z12	d5/D	E	F	GA	k
708	155.0	130	15	4.5	165	M10	23.5	32	58	10	35.0	728.5
710	192.5	180	18	5.0	215	M12	33.0	38	80	10	41.0	790.0

④ DIN 332

⑤ Feather key/keyway DIN 6885

SIMOGEAR Gearboxes

Helical gearbox with adapter KQ

Dimensions

DF/ZF189 gearbox in a flange-mounted design

DZF030KQ

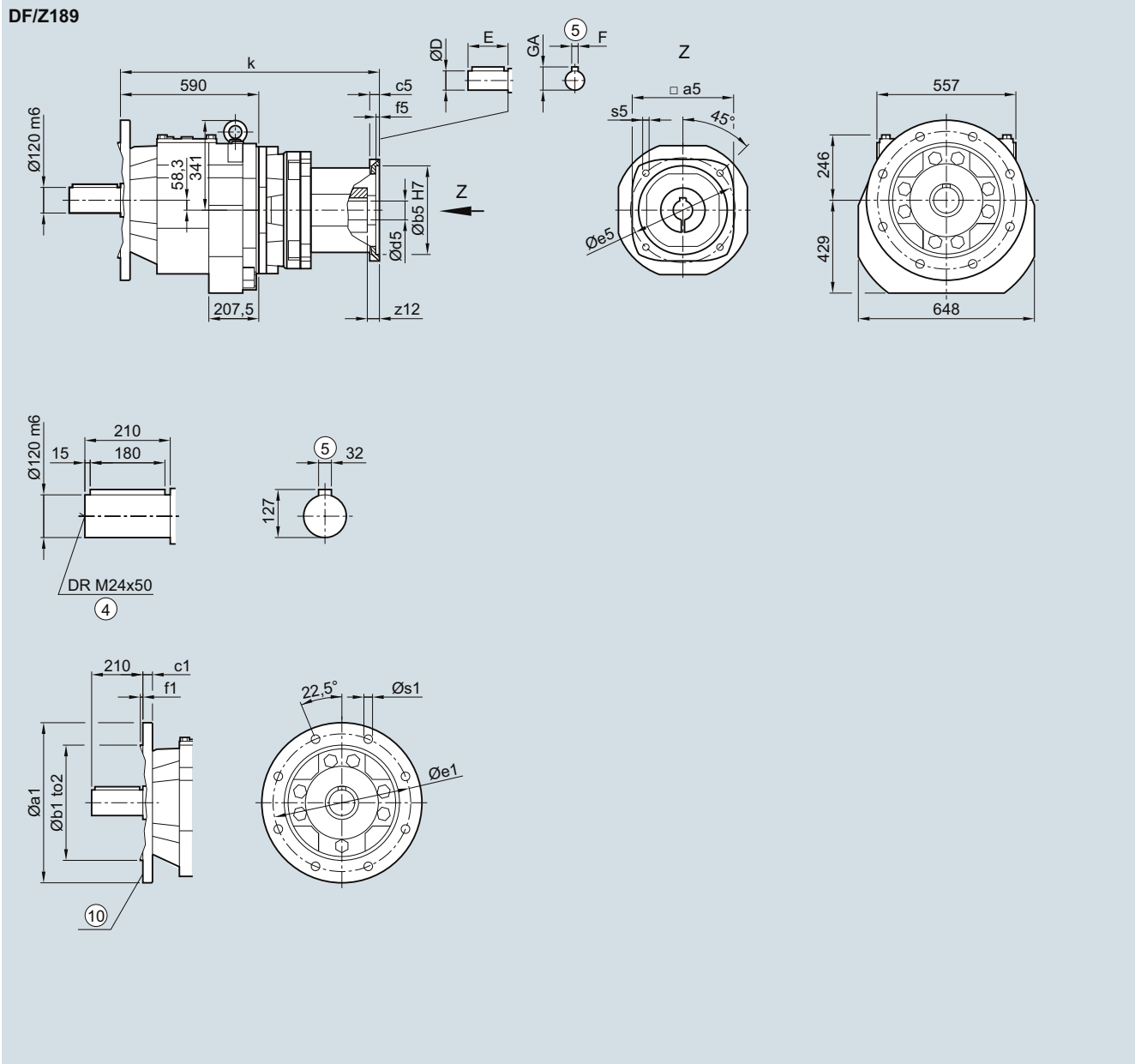

Flange	a1	b1	to2	c1	e1	f1	s1					
	550	450	h6	25	500	5	17.5					
	660	550	h6	28	600	6	22.0					
Adapter	a5	b5	c5	f5	e5	s5	z12	d5/D	E	F	GA	k
708	155.0	130	15	4.5	165	M10	23.5	32	58	10	35.0	728.5
710	192.5	180	18	5.0	215	M12	33.0	38	80	10	41.0	790.0

④ DIN 332

Ⓜ For inner contour, see page 3/111

⑤ Feather key/keyway DIN 6885

D./Z.29 to D./Z.79 gearboxes

DZ030KQS, DZB030KQS, DZF030KQS, DZZ030KQS

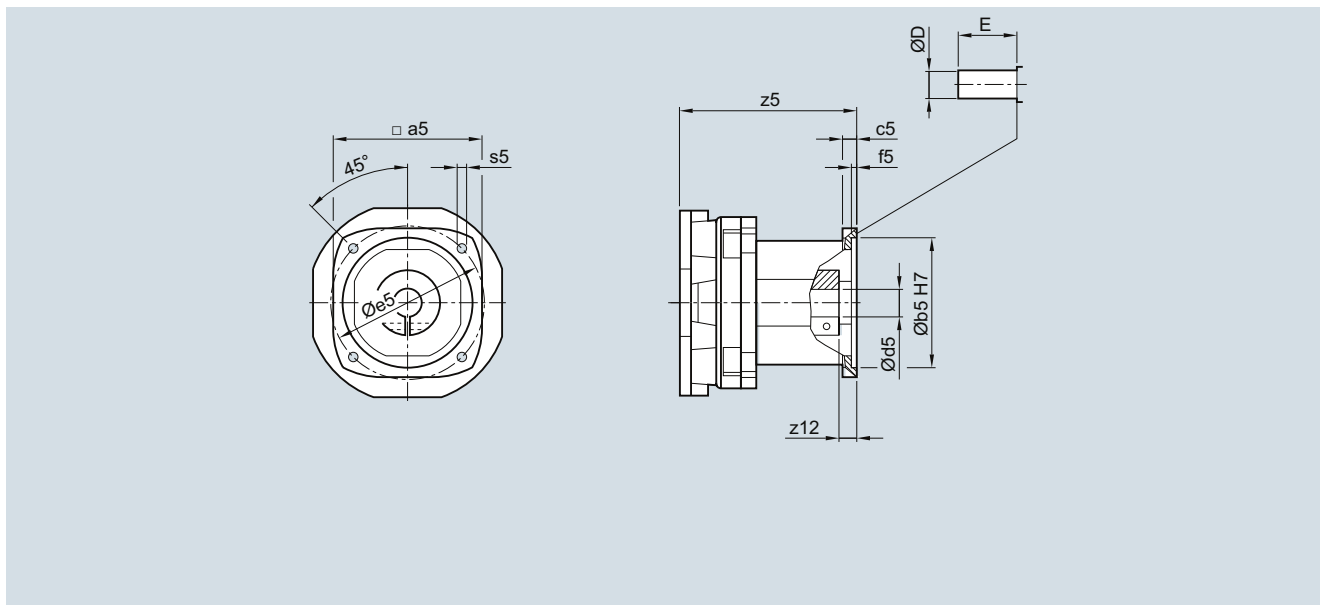

Adapter	a5	b5	c5	f5	e5	s5	z12	d5/D	E	z5
D./Z.29										
703	71.6	60	9	4.0	75	M5	18.0	14	30	99.5
704	96.5	80	10	4.0	100	M6	14.0	19	40	146.5
706	126.0	110	12	4.5	130	M8	15.0	24	50	159.5
D./Z.39										
703	71.6	60	9	4.0	75	M5	18.0	14	30	99.5
704	96.5	80	10	4.0	100	M6	14.0	19	40	146.5
706	126.0	110	12	4.5	130	M8	15.0	24	50	159.5
708	155.0	130	15	4.5	165	M10	23.5	32	58	203.0
D./Z.49										
703	71.6	60	9	4.0	75	M5	18.0	14	30	90.0
704	96.5	80	10	4.0	100	M6	14.0	19	40	137.0
706	126.0	110	12	4.5	130	M8	15.0	24	50	150.0
708	155.0	130	15	4.5	165	M10	23.5	32	58	193.5
710	192.5	180	18	5.0	215	M12	33.0	38	80	262.5
D./Z.59										
703	71.6	60	9	4.0	75	M5	18.0	14	30	90.0
704	96.5	80	10	4.0	100	M6	14.0	19	40	137.0
706	126.0	110	12	4.5	130	M8	15.0	24	50	150.0
708	155.0	130	15	4.5	165	M10	23.5	32	58	193.5
710	192.5	180	18	5.0	215	M12	33.0	38	80	262.5
D./Z.69										
703	71.6	60	9	4.0	75	M5	18.0	14	30	90.0
704	96.5	80	10	4.0	100	M6	14.0	19	40	137.0
706	126.0	110	12	4.5	130	M8	15.0	24	50	150.0
708	155.0	130	15	4.5	165	M10	23.5	32	58	193.5
710	192.5	180	18	5.0	215	M12	33.0	38	80	262.5
D./Z.79										
703	71.6	60	9	4.0	75	M5	18.0	14	30	88.0
704	96.5	80	10	4.0	100	M6	14.0	19	40	131.0
706	126.0	110	12	4.5	130	M8	15.0	24	50	144.0
708	155.0	130	15	4.5	165	M10	23.5	32	58	187.5
710	192.5	180	18	5.0	215	M12	33.0	38	80	256.5

SIMOGEAR Gearboxes

Helical gearbox with adapter KQS

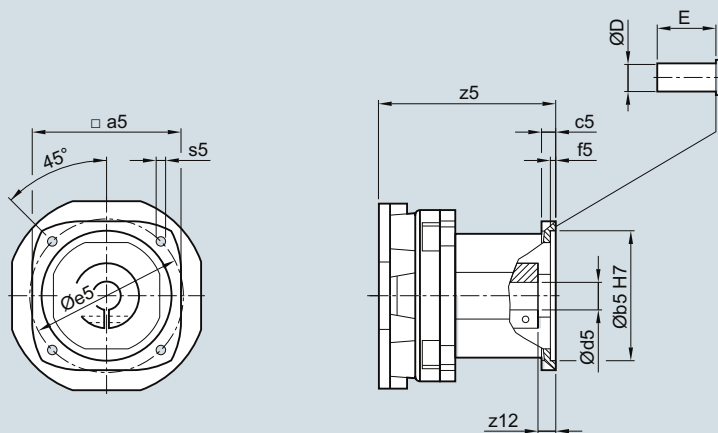
Dimensions**D./Z.89 to D./Z.189 gearboxes****DZ030KQS, DZB030KQS, DZF030KQS, DZZ030KQS**

Adapter	a5	b5	c5	f5	e5	s5	z12	d5/D	E	z5
D./Z.89										
704	96.5	80	10	4.0	100	M6	14.0	19	40	118.0
706	126.0	110	12	4.5	130	M8	15.0	24	50	131.0
708	155.0	130	15	4.5	165	M10	23.5	32	58	170.5
710	192.5	180	18	5.0	215	M12	33.0	38	80	239.5
D./Z.109										
706	126.0	110	12	4.5	130	M8	15.0	24	50	124.0
708	155.0	130	15	4.5	165	M10	23.5	32	58	161.5
710	192.5	180	18	5.0	215	M12	33.0	38	80	230.5
D./Z.129										
706	126.0	110	12	4.5	130	M8	15.0	24	50	117.0
708	155.0	130	15	4.5	165	M10	23.5	32	58	152.5
710	192.5	180	18	5.0	215	M12	33.0	38	80	219.5
D./Z.149										
708	155.0	130	15	4.5	165	M10	23.5	32	58	151.0
710	192.5	180	18	5.0	215	M12	33.0	38	80	213.0
D./Z.169										
708	155.0	130	15	4.5	165	M10	23.5	32	58	138.5
710	192.5	180	18	5.0	215	M12	33.0	38	80	200.0
D./Z.189										
708	155.0	130	15	4.5	165	M10	23.5	32	58	138.5
710	192.5	180	18	5.0	215	M12	33.0	38	80	200.0

D./Z.49 to D./Z.129 gearboxes

DZ030K8, DZB030K8, DZF030K8, DZZ030K8

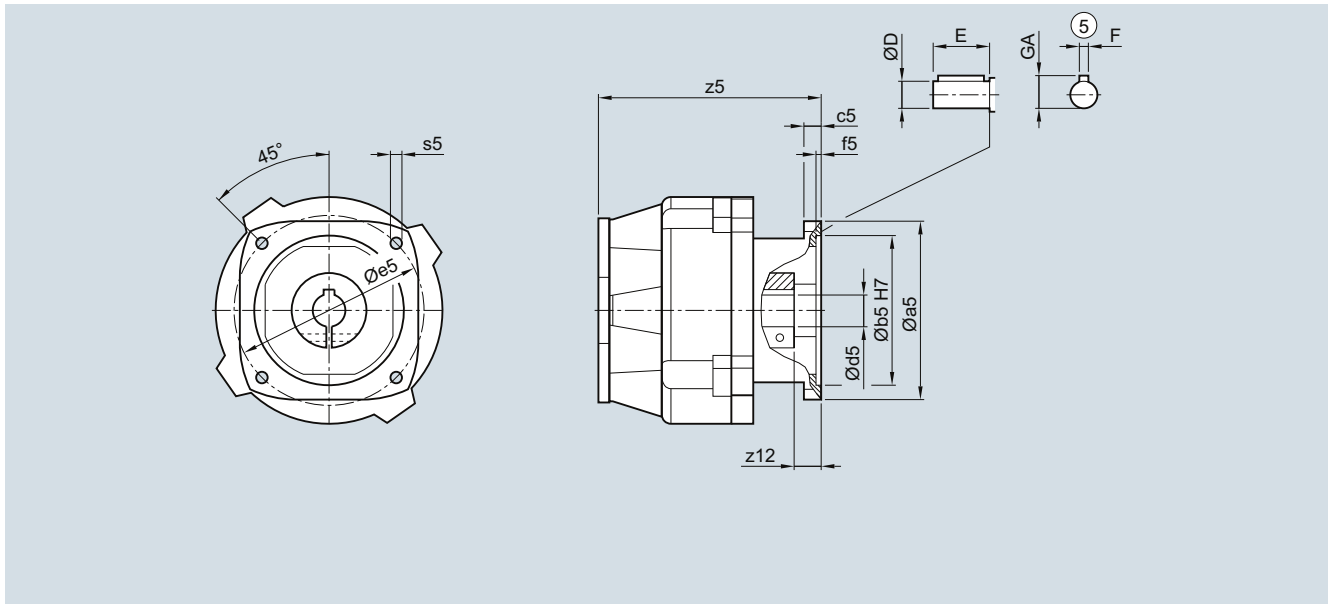

Adapter	a5	b5	c5	f5	e5	s5	z12	d5/D	E	F	GA	z5
D./Z.49												
808	155.0	130	35.0	4.5	165	M10	43.5	32	80	10	35.0	213.5
810	192.5	180	15.0	5.0	215	M12	33.0	38	80	10	41.0	262.5
D./Z.59												
808	155.0	130	35.0	4.5	165	M10	43.5	32	80	10	35.0	213.5
810	192.5	180	15.0	5.0	215	M12	33.0	38	80	10	41.0	262.5
D./Z.69												
808	155.0	130	35.0	4.5	165	M10	43.5	32	80	10	35.0	213.5
810	192.5	180	15.0	5.0	215	M12	33.0	38	80	10	41.0	262.5
D./Z.79												
808	155.0	130	35.0	4.5	165	M10	43.5	32	80	10	35.0	207.5
810	192.5	180	15.0	5.0	215	M12	33.0	38	80	10	41.0	256.5
D./Z.89												
808	155.0	130	35.0	4.5	165	M10	43.5	32	80	10	35.0	190.5
810	192.5	180	15.0	5.0	215	M12	33.0	38	80	10	41.0	239.5
813	260.0	250	25.0	6.0	300	M16	60	48	110	14	51.5	317.5
D./Z.109												
808	155.0	130	35.0	4.5	165	M10	43.5	32	80	10	35.0	181.5
810	192.5	180	15.0	5.0	215	M12	33.0	38	80	10	41.0	230.5
813	260.0	250	25.0	6.0	300	M16	60	48	110	14	51.5	308.5
816	314	300	-	6.0	350	M16x29	60	55	110	16	59.0	365.0
D./Z.129												
808	155.0	130	35.0	4.5	165	M10	43.5	32	80	10	35.0	172.5
810	192.5	180	15.0	5.0	215	M12	33.0	38	80	10	41.0	219.5
813	260.0	250	25.0	6.0	300	M16	60	48	110	14	51.5	297.5
816	314	300	-	6.0	350	M16x29	60	55	110	16	59.0	360.0

© Feather key/keyway DIN 6885

SIMOGEAR Gearboxes

Helical gearbox with adapter K8

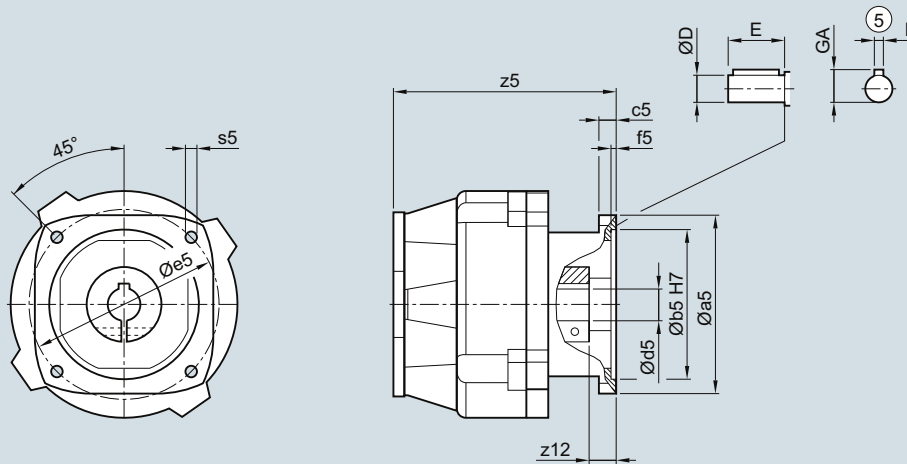
Dimensions**D./Z.149 to D./Z.189 gearboxes****DZ030K8, DZB030K8, DZF030K8, DZZ030K8**

Adapter	a5	b5	c5	f5	e5	s5	z12	d5/D	E	F	GA	z5
D./Z.149												
808	155.0	130	35.0	4.5	165	M10	43.5	32	80	10	35.0	171.0
810	192.5	180	15.0	5.0	215	M12	33.0	38	80	10	41.0	213.0
813	260.0	250	25.0	6.0	300	M16	60	48	110	14	51.5	291.0
816	314	300	-	6.0	350	M16x29	60	55	110	16	59.0	347.5
818	550	350	22.0	12.0	400	M16	73	65	140	18	69	336.5
D./Z.169												
808	155.0	130	35.0	4.5	165	M10	43.5	32	80	10	35.0	158.5
810	192.5	180	15.0	5.0	215	M12	33.0	38	80	10	41.0	200.0
813	260.0	250	25.0	6.0	300	M16	60	48	110	14	51.5	278.0
816	314	300	-	6.0	350	M16x29	60	55	110	16	59.0	333.0
818	550	350	22.0	12.0	400	M16	73	65	140	18	69	319.5
D./Z.189												
808	155.0	130	35.0	4.5	165	M10	43.5	32	80	10	35.0	158.5
810	192.5	180	15.0	5.0	215	M12	33.0	38	80	10	41.0	200.0
813	260.0	250	25.0	6.0	300	M16	60	48	110	14	51.5	278.0
816	314	300	-	6.0	350	M16x29	60	55	110	16	59.0	333.0
818	550	350	22.0	12.0	400	M16	73	65	140	18	69	319.5
822	660	450	58.5	25.0	500	M16	58.5	75	140	20	79.5	346.5

© Feather key/keyway DIN 6885

D./Z.29 to D./Z.89 gearboxes

DZ030K5, DZB030K5, DZF030K5, DZZ030K5

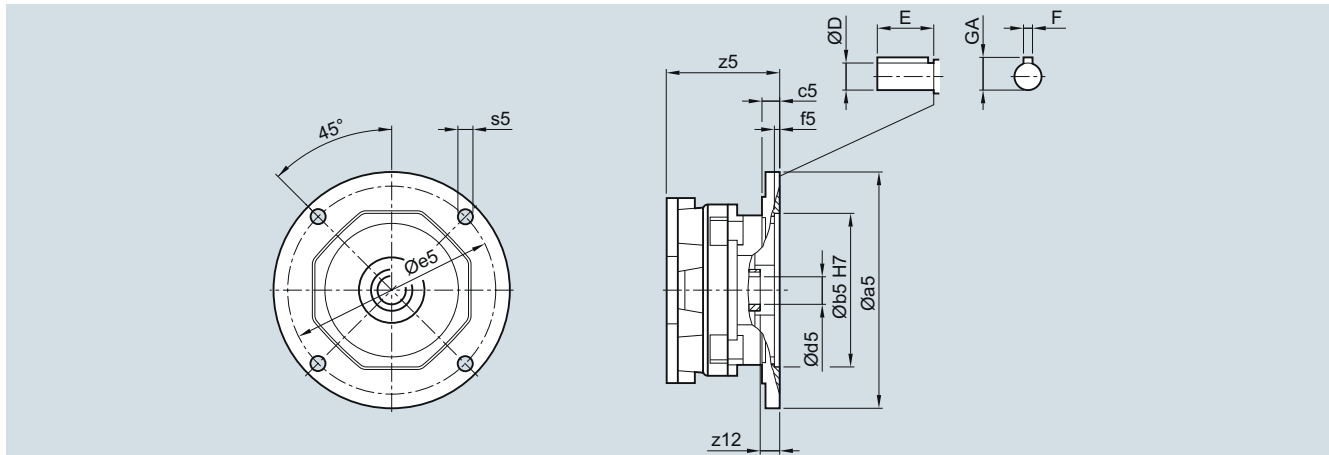

Adapter	a5	b5	c5	f5	e5	s5	z12	d5/D	E	F	GA	z5
D./Z.29												
56	168	114.3	15.0	5.0	149.2	11.0	16.0	15.875	47.752	4.763	17.895	118.5
140	168	114.3	15.0	5.0	149.2	11.0	16.0	22.225	57.150	4.763	24.346	118.5
180	226	215.9	22.0	5.5	184.1	13.5	26.0	28.575	69.850	6.350	31.394	200.5
D./Z.39												
56	168	114.3	15.0	5.0	149.2	11.0	16.0	15.875	47.752	4.763	17.895	118.5
140	168	114.3	15.0	5.0	149.2	11.0	16.0	22.225	57.150	4.763	24.346	118.5
180	226	215.9	22.0	5.5	184.1	13.5	26.0	28.575	69.850	6.350	31.394	200.5
D./Z.49												
56	168	114.3	15.0	5.0	149.2	11.0	16.0	15.875	47.752	4.763	17.895	109.0
140	168	114.3	15.0	5.0	149.2	11.0	16.0	22.225	57.150	4.763	24.346	109.0
180	226	215.9	22.0	5.5	184.1	13.5	26.0	28.575	69.850	6.350	31.394	191.0
210	226	215.9	22.0	5.5	184.1	13.5	12.0	34.925	85.850	7.938	38.443	207.0
D./Z.59												
56	168	114.3	15.0	5.0	149.2	11.0	16.0	15.875	47.752	4.763	17.895	109.0
140	168	114.3	15.0	5.0	149.2	11.0	16.0	22.225	57.150	4.763	24.346	109.0
180	226	215.9	22.0	5.5	184.1	13.5	26.0	28.575	69.850	6.350	31.394	191.0
210	226	215.9	22.0	5.5	184.1	13.5	12.0	34.925	85.850	7.938	38.443	207.0
D./Z.69												
56	168	114.3	15.0	5.0	149.2	11.0	16.0	15.875	47.752	4.763	17.895	109.0
140	168	114.3	15.0	5.0	149.2	11.0	16.0	22.225	57.150	4.763	24.346	109.0
180	226	215.9	22.0	5.5	184.1	13.5	26.0	28.575	69.850	6.350	31.394	191.0
210	226	215.9	22.0	5.5	184.1	13.5	12.0	34.925	85.850	7.938	38.443	207.0
D./Z.79												
56	168	114.3	15.0	5.0	149.2	11.0	16.0	15.875	47.752	4.763	17.895	103.0
140	168	114.3	15.0	5.0	149.2	11.0	16.0	22.225	57.150	4.763	24.346	103.0
180	226	215.9	22.0	5.5	184.1	13.5	26.0	28.575	69.850	6.350	31.394	185.0
210	226	215.9	22.0	5.5	184.1	13.5	12.0	34.925	85.850	7.938	38.443	201.0
250	226	215.9	22.0	5.5	184.1	13.5	12.0	41.275	101.600	9.525	45.491	201.0
D./Z.89												
140	168	114.3	15.0	5.0	149.2	11.0	16.0	22.225	57.150	4.763	24.346	90.0
180	226	215.9	22.0	5.5	184.1	13.5	26.0	28.575	69.850	6.350	31.394	168.0
210	226	215.9	22.0	5.5	184.1	13.6	12.0	34.925	85.850	7.938	38.443	184.0
250	226	215.9	22.0	5.5	184.1	13.5	12.0	41.275	101.600	9.525	45.491	184.0

SIMOGEAR Gearboxes

Helical gearbox with adapter K5

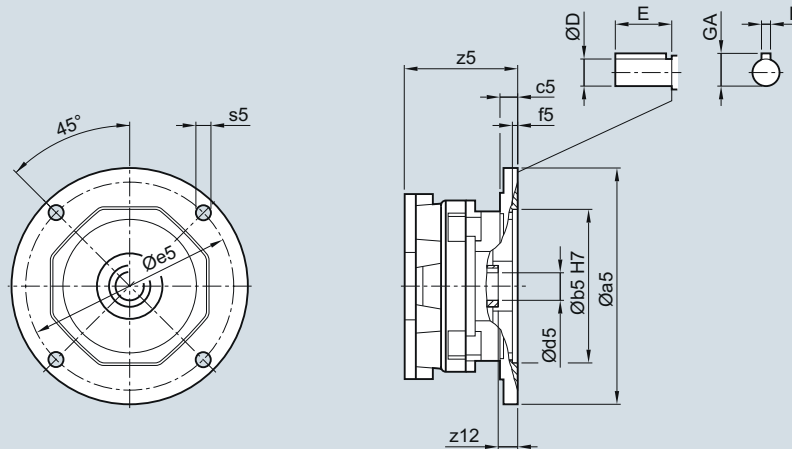
Dimensions**D./Z.109 to D./Z.189 gearboxes****DZ030K5, DZB030K5, DZF030K5, DZZ030K5**

Adapter	a5	b5	c5	f5	e5	s5	z12	d5/D	E	F	GA	z5
D./Z.109												
140	168	114.3	15.0	5.0	149.2	11.0	16.0	22.225	57.150	4.763	24.346	83.0
180	226	215.9	22.0	5.5	184.1	13.5	26.0	28.575	69.850	6.350	31.394	159.0
210	226	215.9	22.0	5.5	184.1	13.6	12.0	34.925	85.850	7.938	38.443	175.0
250	226	215.9	22.0	5.5	184.1	13.5	12.0	41.275	101.600	9.525	45.491	175.0
280	285	266.7	24.5	5.5	228.6	13.2	22.0	47.625	117.602	12.7	53.111	188.0
320	340	317.5	26.5	5.5	279.4	17.0	32.5	53.975	133.35	12.7	59.563	264.5
D./Z.129												
140	168	114.3	15.0	5.0	149.2	11.0	16.0	22.225	57.150	4.763	24.346	76.0
180	226	215.9	22.0	5.5	184.1	13.5	26.0	28.575	69.850	6.350	31.394	150.0
210	226	215.9	22.0	5.5	184.1	13.6	12.0	34.925	85.850	7.938	38.443	164.0
250	226	215.9	22.0	5.5	184.1	13.5	12.0	41.275	101.600	9.525	45.491	164.0
280	285	266.7	24.5	5.5	228.6	13.2	22.0	47.625	117.602	12.7	53.111	177.0
320	340	317.5	26.5	5.5	279.4	17.0	32.5	53.975	133.35	12.7	59.563	259.5
360	340	317.5	26.5	5.5	279.4	17.0	34.5	60.325	149.352	15.875	67.208	278.0
D./Z.149												
180	226	215.9	22.0	5.5	184.1	13.5	26.0	28.575	69.850	6.350	31.394	148.5
210	226	215.9	22.0	5.5	184.1	13.6	12.0	34.925	85.850	7.938	38.443	157.5
250	226	215.9	22.0	5.5	184.1	13.5	12.0	41.275	101.600	9.525	45.491	157.5
280	285	266.7	24.5	5.5	228.6	13.2	22.0	47.625	117.602	12.7	53.111	170.5
320	340	317.5	26.5	5.5	279.4	17.0	32.5	53.975	133.35	12.7	59.563	247.0
360	340	317.5	26.5	5.5	279.4	17.0	34.5	60.325	149.352	15.875	67.208	271.5
D./Z.169												
210	226	215.9	22.0	5.5	184.1	13.6	12.0	34.925	85.850	7.938	38.443	144.5
250	226	215.9	22.0	5.5	184.1	13.5	12.0	41.275	101.600	9.525	45.491	144.5
280	285	266.7	24.5	5.5	228.6	13.2	22.0	47.625	117.602	12.7	53.111	157.5
320	340	317.5	26.5	5.5	279.4	17.0	32.5	53.975	133.35	12.7	59.563	232.5
360	340	317.5	26.5	5.5	279.4	17.0	34.5	60.325	149.352	15.875	67.208	253.0
D./Z.189												
210	226	215.9	22.0	5.5	184.1	13.6	12.0	34.925	85.850	7.938	38.443	144.5
250	226	215.9	22.0	5.5	184.1	13.5	12.0	41.275	101.600	9.525	45.491	144.5
280	285	266.7	24.5	5.5	228.6	13.2	22.0	47.625	117.602	12.7	53.111	157.5
320	340	317.5	26.5	5.5	279.4	17.0	32.5	53.975	133.35	12.7	59.563	232.5
360	340	317.5	26.5	5.5	279.4	17.0	34.5	60.325	149.352	15.875	67.208	253.0

D./Z.29 to D./Z.89 gearboxes

DZ030K3, DZB030K3, DZF030K3, DZZ030K3

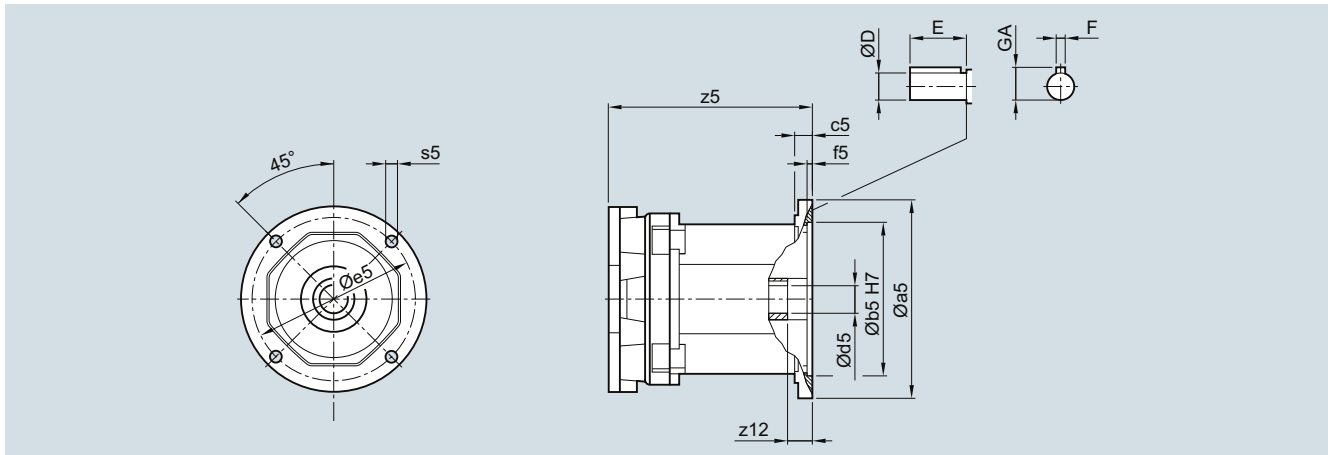

Adapter	a5	b5	c5	f5	e5	s5	z12	d5/D	E	F	GA	z5
D./Z.29												
56	168	114.3	15.0	5.0	149.2	11.0	27.5	15.875	47.752	4.763	17.895	201.0
140	168	114.3	15.0	5.0	149.2	11.0	28.0	22.225	57.150	4.763	24.346	201.0
180	226	215.9	22.0	5.5	184.1	13.5	42	28.575	69.85	6.35	31.394	257.0
D./Z.39												
56	168	114.3	15.0	5.0	149.2	11.0	27.5	15.875	47.752	4.763	17.895	201.0
140	168	114.3	15.0	5.0	149.2	11.0	28.0	22.225	57.150	4.763	24.346	201.0
180	226	215.9	22.0	5.5	184.1	13.5	42.0	28.575	69.850	6.350	31.394	257.0
D./Z.49												
56	168	114.3	15.0	5.0	149.2	11.0	27.5	15.875	47.752	4.763	17.895	191.5
140	168	114.3	15.0	5.0	149.2	11.0	28.0	22.225	57.150	4.763	24.346	191.5
180	226	215.9	22.0	5.5	184.1	13.5	42.0	28.575	69.850	6.350	31.394	247.5
210	226	215.9	22.0	5.5	184.1	13.5	49.5	34.925	85.850	7.938	38.443	318.0
D./Z.59												
56	168	114.3	15.0	5.0	149.2	11.0	27.5	15.875	47.752	4.763	17.895	191.5
140	168	114.3	15.0	5.0	149.2	11.0	28.0	22.225	57.150	4.763	24.346	191.5
180	226	215.9	22.0	5.5	184.1	13.5	42.0	28.575	69.850	6.350	31.394	247.5
210	226	215.9	22.0	5.5	184.1	13.5	49.5	34.925	85.850	7.938	38.443	318.0
D./Z.69												
56	168	114.3	15.0	5.0	149.2	11.0	27.5	15.875	47.752	4.763	17.895	191.5
140	168	114.3	15.0	5.0	149.2	11.0	28.0	22.225	57.150	4.763	24.346	191.5
180	226	215.9	22.0	5.5	184.1	13.5	42.0	28.575	69.850	6.350	31.394	247.5
210	226	215.9	22.0	5.5	184.1	13.5	49.5	34.925	85.850	7.938	38.443	318.0
D./Z.79												
56	168	114.3	15.0	5.0	149.2	11.0	27.5	15.875	47.752	4.763	17.895	185.5
140	168	114.3	15.0	5.0	149.2	11.0	28.0	22.225	57.150	4.763	24.346	185.5
180	226	215.9	22.0	5.5	184.1	13.5	42.0	28.575	69.850	6.350	31.394	241.5
210	226	215.9	22.0	5.5	184.1	13.5	49.5	34.925	85.850	7.938	38.443	312.0
250	226	215.9	22.0	5.5	184.1	13.5	55.5	41.275	101.600	9.525	45.491	342.0
D./Z.89												
140	168	114.3	15.0	5.0	149.2	11.0	28.0	22.225	57.150	4.763	24.346	172.5
180	226	215.9	22.0	5.5	184.1	13.5	42.0	28.575	69.850	6.350	31.394	224.5
210	226	215.9	22.0	5.5	184.1	13.5	49.5	34.925	85.850	7.938	38.443	295.0
250	226	215.9	22.0	5.5	184.1	13.5	55.5	41.275	101.600	9.525	45.491	325.0

SIMOGEAR Gearboxes

Helical gearbox with adapter K3

Dimensions

D./Z.109 to D./Z.189 gearboxes

DZ030K3, DZB030K3, DZF030K3, DZZ030K3

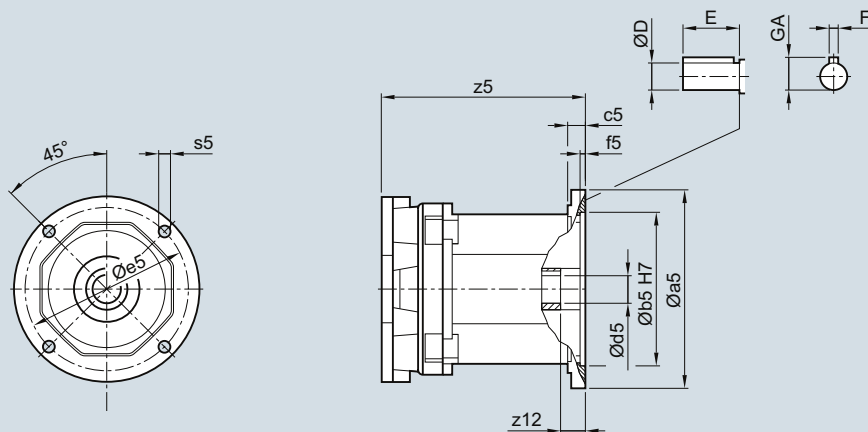

Adapter	a5	b5	c5	f5	e5	s5	z12	d5/D	E	F	GA	z5
D./Z.109												
140	168	114.3	15.0	5.0	149.2	11.0	28.0	22.225	57.150	4.763	24.346	165.5
180	226	215.9	22.0	5.5	184.1	13.5	42.0	28.575	69.850	6.350	31.394	215.5
210	226	215.9	22.0	5.5	184.1	13.5	49.5	34.925	85.850	7.938	38.443	286.0
250	226	215.9	22.0	5.5	184.1	13.5	55.5	41.275	101.600	9.525	45.491	316.0
280	285	266.7	24.5	5.5	228.6	13.5	66.5	47.625	117.602	12.7	53.111	334.0
320	340	317.5	26.5	5.5	279.4	17.0	76.5	53.975	133.35	12.7	59.563	411.5
D./Z.129												
140	168	114.3	15.0	5.0	149.2	11.0	28.0	22.225	57.150	4.763	24.346	158.5
180	226	215.9	22.0	5.5	184.1	13.5	42.0	28.575	69.850	6.350	31.394	206.5
210	226	215.9	22.0	5.5	184.1	13.5	49.5	34.925	85.850	7.938	38.443	275.0
250	226	215.9	22.0	5.5	184.1	13.5	55.5	41.275	101.600	9.525	45.491	305.0
280	285	266.7	24.5	5.5	228.6	13.5	66.5	47.625	117.602	12.7	53.111	323.0
320	340	317.5	26.5	5.5	279.4	17.0	76.5	53.975	133.35	12.7	59.563	406.5
360	340	317.5	26.5	5.5	279.4	17.0	76.5	60.325	149.352	15.875	67.21	454.0
D./Z.149												
180	226	215.9	22.0	5.5	184.1	13.5	42.0	28.575	69.850	6.350	31.394	205.0
210	226	215.9	22.0	5.5	184.1	13.5	49.5	34.925	85.850	7.938	38.443	268.5
250	226	215.9	22.0	5.5	184.1	13.5	55.5	41.275	101.600	9.525	45.491	298.5
280	285	266.7	24.5	5.5	228.6	13.5	66.5	47.625	117.602	12.7	53.111	316.5
320	340	317.5	26.5	5.5	279.4	17.0	76.5	53.975	133.35	12.7	59.563	394.0
360	340	317.5	26.5	5.5	279.4	17.0	76.5	60.325	149.352	15.875	67.21	447.5
D./Z.169												
210	226	215.9	22.0	5.5	184.1	13.5	49.5	34.925	85.850	7.938	38.443	255.5
250	226	215.9	22.0	5.5	184.1	13.5	55.5	41.275	101.600	9.525	45.491	285.5
280	285	266.7	24.5	5.5	228.6	13.5	66.5	47.625	117.602	12.7	53.111	303.5
320	340	317.5	26.5	5.5	279.4	17.0	76.5	53.975	133.35	12.7	59.563	379.0
360	340	317.5	26.5	5.5	279.4	17.0	76.5	60.325	149.352	15.875	67.21	429.0
D./Z.189												
210	226	215.9	22.0	5.5	184.1	13.5	49.5	34.925	85.850	7.938	38.443	255.5
250	226	215.9	22.0	5.5	184.1	13.5	55.5	41.275	101.600	9.525	45.491	285.5
280	285	266.7	24.5	5.5	228.6	13.5	66.5	47.625	117.602	12.7	53.111	303.5
320	340	317.5	26.5	5.5	279.4	17.0	76.5	53.975	133.35	12.7	59.563	379.0
360	340	317.5	26.5	5.5	279.4	17.0	76.5	60.325	149.352	15.875	67.21	429.0

Inner contour of the flange design

Notes regarding the design of the customer's interface.

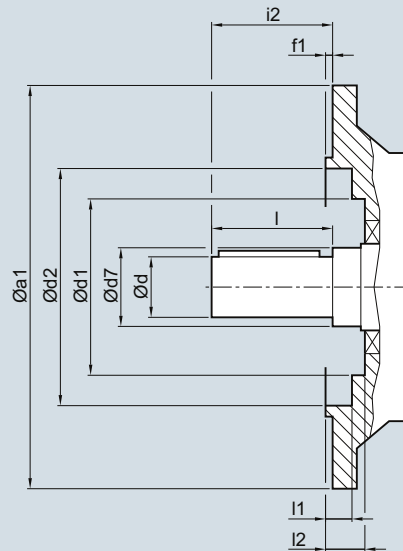

Gearbox	a1	d	d7	d1 DF/ZF	d1 DB/ZB	d2	f1	i2	l	l1 DF/ZF	l1 DB/ZB	l2
DF/ZF19, DB/ZB19	120	16	25	48.0	48.0	72.0	3.0	40	28	1.0	1.0	6.0
	120	16	25	48.0	48.0	72.0	3.0	40	40	1.0	1.0	6.0
	120	20	25	48.0	48.0	72.0	3.0	40	40	1.0	1.0	6.0
DF/ZF19	140	20	25	48.0	-	87.0	3.0	40	40	1.0	-	6.0
	160	20	25	48.0	-	102.0	3.5	40	40	1.0	-	6.5
DF/ZF29, /DB/ZB29	120	25	30	56.0	56.0	72.0	3.0	50	50	2.0	2.0	8.0
DF/ZF29	140	25	30	56.0	-	87.0	3.5	50	50	2.0	-	7.0
	160	25	30	56.0	-	102.0	3.5	50	50	2.0	-	7.5
DF/ZF39, DB/ZB39	120	25	35	69.0	66.0	72.0	3.0	50	50	4.0	4.0	9.0
DF/ZF39	160	25	35	66.5	-	102.0	3.5	50	50	1.5	-	6.5
	200	25	35	66.5	-	120.0	3.5	50	50	1.5	-	6.5
DF/ZF49, DB/ZB49	140	30	35	79.0	79.0	84.5	3.0	60	60	4.0	4.0	9.5
DF/ZF49	160	30	35	79.0	-	94.5	3.5	60	60	5.5	-	11.0
	200	30	35	79.0	-	121.0	3.5	60	60	4.5	-	10.0
DF/ZF59, DB/ZB59	160	35	40	88.0	88.0	94.5	3.5	70	70	4.5	4.5	11.0
DF/ZF59	200	35	40	88.0	-	115.0	3.5	70	70	4.5	-	9.0
	250	35	40	88.0	-	168.0	4.0	70	70	4.0	-	10.5
DF/ZF69, DB/ZB69	200	35	47	105.0	105.0	115.0	3.5	70	70	4.5	4.5	11.0
DF/ZF69	250	35	47	105.0	-	168.0	4.0	70	70	4.0	-	10.5
DF/ZF79, DB/ZB79	250	40	52	113.0	114.5	168.0	4.0	80	80	0.5	2.5	8.0
DF/ZF79	300	40	52	113.0	-	217.0	4.0	80	80	0.5	-	8.0
DF/ZF89, DB/ZB89	300	50	62	143.0	143.0	218.0	4.0	100	100	1.5	1.5	9.0
DF/ZF89	350	50	62	143.0	-	238.0	5.0	100	100	2.5	-	10.0
DF/ZF109	350	60	65	157.0	-	236.0	5.0	120	120	2.0	-	12.0
	450	60	65	168.0	-	335.0	5.0	120	120	2.0	-	12.0
DF/ZF129	350	70	75	180.0	-	236.0	5.0	140	140	7.5	-	20.0
	450	70	75	180.0	-	330.0	5.0	140	140	7.5	-	20.0
DF/ZF149	450	90	100	225.0	-	330.0	5.0	170	170	2.5	-	10.0
	550	90	100	225.0	-	430.0	5.0	170	170	2.5	-	10.0
DF/ZF169	450	110	120	235.0	-	330.0	5.0	210	210	0.5	-	10.0
	550	110	120	235.0	-	430.0	5.0	210	210	0.5	-	10.0
DF/ZF189	550	120	140	274.0	-	430.0	5.0	210	210	-	-	10.0
	660	120	140	274.0	-	530.0	6.0	210	210	1.0	-	11.0

SIMOGEAR Gearboxes

Notes

3

Parallel Shaft Gearboxes

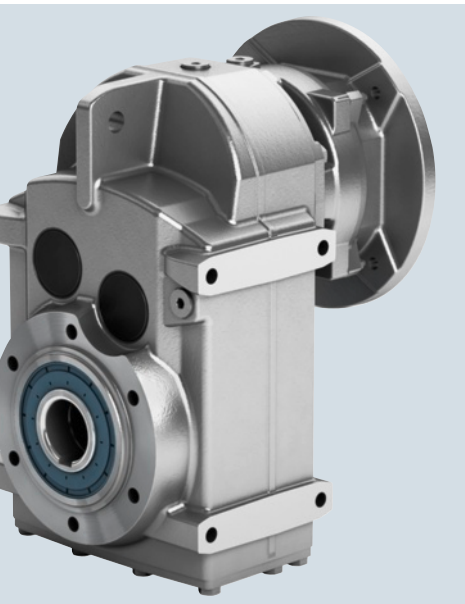

4/2	Orientation	4/75	Dimensions (continued)
4/3	Transmission ratios and torques	4/75	Parallel shaft gearbox with adapter KQ
4/3	Selection and ordering data	4/76	FDAD./FZAD.29
4/25	Dimensions	4/77	FD.Z./FZ.Z.29
4/25	Dimensional drawing overview	4/78	FD.F./FZ.F.29
	Parallel shaft gearbox with adapter K4	4/79	FD../FZ..29
4/28	FDAD./FZAD.29	4/80	FDAD./FZAD.39
4/29	FD.Z./FZ.Z.29	4/81	FD.Z./FZ.Z.39
4/30	FD.F./FZ.F.29	4/82	FD.F./FZ.F.39
4/31	FD../FZ..29	4/83	FD../FZ..39
4/32	FDAD./FZAD.39	4/84	FDAD./FZAD.49
4/33	FD.Z./FZ.Z.39	4/85	FD.Z./FZ.Z.49
4/34	FD.F./FZ.F.39	4/86	FD.F./FZ.F.49
4/35	FD../FZ..39	4/87	FD../FZ..49
4/36	FDAD./FZAD.49	4/88	FDAD./FZAD.69
4/37	FD.Z./FZ.Z.49	4/89	FD.Z./FZ.Z.69
4/38	FD.F./FZ.F.49	4/90	FD.F./FZ.F.69
4/39	FD../FZ..49	4/91	FD../FZ..69
4/40	FDAD./FZAD.69	4/92	FDAD./FZAD.79
4/41	FD.Z./FZ.Z.69	4/93	FD.Z./FZ.Z.79
4/42	FD.F./FZ.F.69	4/94	FD.F./FZ.F.79
4/43	FD../FZ..69	4/95	FD../FZ..79
4/44	FDAD./FZAD.79	4/96	FDAD./FZAD.89
4/45	FD.Z./FZ.Z.79	4/97	FD.Z./FZ.Z.89
4/46	FD.F./FZ.F.79	4/98	FD.F./FZ.F.89
4/47	FD../FZ..79	4/99	FD../FZ..89
4/48	FDAD./FZAD.89	4/100	FDAD./FZAD.109
4/49	FD.Z./FZ.Z.89	4/101	FD.Z./FZ.Z.109
4/50	FD.F./FZ.F.89	4/102	FD.F./FZ.F.109
4/51	FD../FZ..89	4/103	FD../FZ..109
4/52	FDAD./FZAD.109	4/104	FDAD./FZAD.129
4/53	FD.Z./FZ.Z.109	4/105	FD.Z./FZ.Z.129
4/54	FD.F./FZ.F.109	4/106	FD.F./FZ.F.129
4/55	FD../FZ..109	4/107	FD../FZ..129
4/56	FDAD./FZAD.129	4/108	FDAD./FZAD.149
4/57	FD.Z./FZ.Z.129	4/109	FD.Z./FZ.Z.149
4/58	FD.F./FZ.F.129	4/110	FD.F./FZ.F.149
4/59	FD../FZ..129	4/111	FD../FZ..149
4/60	FDAD./FZAD.149	4/112	FDAD./FZAD.169
4/61	FD.Z./FZ.Z.149	4/113	FD.Z./FZ.Z.169
4/62	FD.F./FZ.F.149	4/114	FD.F./FZ.F.169
4/63	FD../FZ..149	4/115	FD../FZ..169
4/64	FDAD./FZAD.169	4/116	FDAD./FZAD.189
4/65	FD.Z./FZ.Z.169	4/117	FD.Z./FZ.Z.189
4/66	FD.F./FZ.F.169	4/118	FD.F./FZ.F.189
4/67	FD../FZ..169	4/119	FD../FZ..189
4/68	FDAD./FZAD.189		Parallel shaft gearbox with adapter KQS
4/69	FD.Z./FZ.Z.189	4/119	FD../FZ..29 bis FD../FZ..189
4/70	FD.F./FZ.F.189		Parallel shaft gearbox with adapter K8
4/71	FD../FZ..189	4/121	FD../FZ..39 bis FD../FZ..189
	Parallel shaft gearbox with adapter K2		Parallel shaft gearbox with adapter K5
4/72	FD../FZ..29 bis FD../FZ..189	4/122	FD../FZ..29 bis FD../FZ..189
		4/124	Parallel shaft gearbox with adapter K3
		4/126	FD../FZ..29 bis FD../FZ..189
		4/128	SIMOLOC assembly system
		4/129	Protection cover for hollow shaft
		4/131	Inner contour of the flange design
			Pin holes

SIMOGEAR Gearboxes

Parallel shaft gearbox

Orientation

SIMOGEAR parallel shaft gearbox F

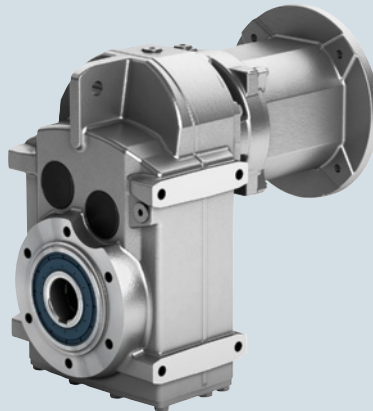

Fig. 4/1 Parallel shaft gearbox F

Gearbox designation	Number of sizes	Maximum output torque	Transmission ratio	Maximum motor power
		T_{2N} Nm	i -	P_1 kW
FZ29 ... FZ189 (2-stage)	11	150 ... 19 000	3.5 ... 70	200
FD29 ... FD189 (3-stage)	11	150 ... 19 000	32 ... 413	200

SIMOGEAR parallel shaft gearboxes are available in the following versions for mounting in any position:

- 2 or 3 stages FZ/FD
- Shaft-mounted design with torque arm FZAD/FDAD
- Flange-mounted design FZF/FDF
- Design with integrated housing flange FZZ/FDZ
- Foot-mounted design FZ/FD
- Hollow-shaft design with feather key FZA/FDA
- Hollow-shaft design with splined shaft FZAT/FDAT
- Hollow-shaft design with shrink disk FZAS/FDAS
- Hollow-shaft design with SIMOLOC assembly system FZADR/FDADR
- Solid shaft design with and without feather key FZ/FD

Selection and ordering data

Gearbox							Adapter													Article No.				
i	n_2	T_{2N}	F_{R2}	ϕ ¹⁾	J_G	R_{ex}	K4	63	71	80	90	100	112	132	160	180	200	225	250			(Article No. supplement → below)		
-	rpm	Nm	N	'	10^{-4}	-	K2			80	90	100	112	132	160	180	200	225	250	280	315			
							KQ	703	704	706			708	710										
							K8						808	810		813		816		818	822			
							K5	56		140	180		210	250		280	320	360						
							K3	56		140	180		210	250		280	320	360						
FD.29																								
298.58	4.9	150	5 220	15	0.02	94054/315	✓	✓															2KJ3401 - ■ ■ A 0 ■ - 0 ■ Q1	
264.39	5.5	150	5 220	15	0.03	92537/350	✓	✓	✓															2KJ3401 - ■ ■ A 0 ■ - 0 ■ P1
229.72	6.3	150	5 220	15	0.04	80401/350	✓	✓	✓															2KJ3401 - ■ ■ A 0 ■ - 0 ■ N1
208.83	6.9	150	5 220	15	0.05	80401/385	✓	✓	✓	✓														2KJ3401 - ■ ■ A 0 ■ - 0 ■ M1
177.71	8.2	150	5 220	15	0.06	62197/350	✓	✓	✓	✓														2KJ3401 - ■ ■ A 0 ■ - 0 ■ L1
161.55	9	150	5 220	15	0.08	62197/385	✓	✓	✓	✓														2KJ3401 - ■ ■ A 0 ■ - 0 ■ K1
140.86	10	150	5 220	16	0.09	19721/140	✓	✓	✓	✓	✓													2KJ3401 - ■ ■ A 0 ■ - 0 ■ J1
126.09	11	150	5 220	16	0.12	48544/385	✓	✓	✓	✓	✓													2KJ3401 - ■ ■ A 0 ■ - 0 ■ H1
111.97	13	150	5 220	16	0.14	47027/420	✓	✓	✓	✓	✓													2KJ3401 - ■ ■ A 0 ■ - 0 ■ G1
103.36	14	150	5 220	16	0.17	47027/455	✓	✓	✓	✓	✓													2KJ3401 - ■ ■ A 0 ■ - 0 ■ F1
89.78	16	150	5 220	16	0.19	43993/490	✓	✓	✓	✓	✓													2KJ3401 - ■ ■ A 0 ■ - 0 ■ E1
78.02	19	150	5 220	16	0.19	13653/175	✓	✓	✓	✓	✓													2KJ3401 - ■ ■ A 0 ■ - 0 ■ D1
70.43	21	150	5 220	16	0.25	19721/280	✓	✓	✓	✓	✓													2KJ3401 - ■ ■ A 0 ■ - 0 ■ C1
66.29	22	150	5 220	16	0.29	39442/595	✓	✓	✓	✓	✓													2KJ3401 - ■ ■ A 0 ■ - 0 ■ B1
57.79	25	150	5 220	16	0.33	6068/105	✓	✓	✓	✓	✓													2KJ3401 - ■ ■ A 0 ■ - 0 ■ A1

¹⁾ Only in conjunction with reduced-backlash version

Article No. supplement		1 or 9																						
Shaft design	→ Page 9/39																							
Adapter size		K4	B	C	D	E	F	G	H	J	K	L	M	N										4
		K2			D	E	F	G	H	J	K	L	M	N	P	Q								2
		KQ		A	B	C		D	E															7
		K8						A	B		C		D	E	F									8
		K5		A		B	C		D	E		F	G	H										5
		K3		A		B	C		D	E		F	G	H										3
Adapter type																								
Gearbox mounting type	→ Page 9/34	A, B, F or H																						

SIMOGEAR Gearboxes

Parallel shaft gearbox

Transmission ratios and torques

Selection and ordering data

Gearbox							Adapter													Article No.			
<i>i</i>	<i>n</i> ₂	<i>T</i> _{2N}	<i>F</i> _{R2}	ϕ ¹⁾	<i>J</i> _G	<i>R</i> _{ex}	K4	63	71	80	90	100	112	132	160	180	200	225	250	280	315	(Article No. supplement → below)	
-	rpm	Nm	N	'	10 ⁻⁴	-	K2			80	90	100	112	132	160	180	200	225	250	280	315		
							KQ	703	704	706			708	710									
							K8						808	810		813		816		818	822		
							K5	56		140	180			210	250			280	320	360			
							K3	56		140	180			210	250			280	320	360			

FZ.29																									
56.73	26	150	5 220	15	0.04	851/15	✓	✓																	2KJ3301 - ■ ■ A 0 ■ - 0 ■ C2
50.32	29	150	5 220	15	0.05	1258/25	✓	✓	✓																2KJ3301 - ■ ■ A 0 ■ - 0 ■ B2
43.66	33	150	5 220	15	0.06	2183/50	✓	✓	✓																2KJ3301 - ■ ■ A 0 ■ - 0 ■ A2
39.69	37	150	5 220	15	0.08	2183/55	✓	✓	✓	✓															2KJ3301 - ■ ■ A 0 ■ - 0 ■ X1
34.04	43	150	4 920	16	0.10	851/25	✓	✓	✓	✓															2KJ3301 - ■ ■ A 0 ■ - 0 ■ W1
30.95	47	150	4 730	16	0.12	1702/55	✓	✓	✓	✓															2KJ3301 - ■ ■ A 0 ■ - 0 ■ V1
27.13	53	150	4 470	16	0.14	407/15	✓	✓	✓	✓	✓														2KJ3301 - ■ ■ A 0 ■ - 0 ■ U1
24.22	60	150	4 260	16	0.17	1332/55	✓	✓	✓	✓	✓														2KJ3301 - ■ ■ A 0 ■ - 0 ■ T1
21.58	67	150	4 050	16	0.20	259/12	✓	✓	✓	✓	✓														2KJ3301 - ■ ■ A 0 ■ - 0 ■ S1
19.92	73	150	3 910	16	0.24	259/13	✓	✓	✓	✓	✓														2KJ3301 - ■ ■ A 0 ■ - 0 ■ R1
17.44	83	150	3 690	16	0.28	1221/70	✓	✓	✓	✓	✓														2KJ3301 - ■ ■ A 0 ■ - 0 ■ Q1
15.29	95	150	3 480	16	0.30	1147/75	✓	✓	✓	✓	✓														2KJ3301 - ■ ■ A 0 ■ - 0 ■ P1
13.88	104	150	3 320	16	0.38	111/8	✓	✓	✓	✓	✓														2KJ3301 - ■ ■ A 0 ■ - 0 ■ N1
13.06	111	150	3 230	16	0.44	222/17	✓	✓	✓	✓	✓														2KJ3301 - ■ ■ A 0 ■ - 0 ■ M1
11.51	126	143	3 110	16	0.50	518/45	✓	✓	✓	✓	✓														2KJ3301 - ■ ■ A 0 ■ - 0 ■ L1
9.99	145	136	2 970	16	0.67	999/100	✓	✓	✓	✓	✓														2KJ3301 - ■ ■ A 0 ■ - 0 ■ K1
9.69	150	143	2 670	23	0.26	2664/275	✓	✓	✓	✓	✓														2KJ3301 - ■ ■ A 0 ■ - 0 ■ J1
8.63	168	130	2 640	24	0.32	259/30	✓	✓	✓	✓	✓														2KJ3301 - ■ ■ A 0 ■ - 0 ■ H1
7.97	182	120	2 630	24	0.38	518/65	✓	✓	✓	✓	✓														2KJ3301 - ■ ■ A 0 ■ - 0 ■ G1
6.98	208	123	2 440	24	0.46	1221/175	✓	✓	✓	✓	✓														2KJ3301 - ■ ■ A 0 ■ - 0 ■ F1
6.12	237	114	2 370	25	0.53	2294/375	✓	✓	✓	✓	✓														2KJ3301 - ■ ■ A 0 ■ - 0 ■ E1
5.55	261	108	2 320	25	0.66	111/20	✓	✓	✓	✓	✓														2KJ3301 - ■ ■ A 0 ■ - 0 ■ D1
5.22	278	106	2 300	25	0.76	444/85	✓	✓	✓	✓	✓														2KJ3301 - ■ ■ A 0 ■ - 0 ■ C1
4.60	315	97	2 280	24	0.92	1036/225	✓	✓	✓	✓	✓														2KJ3301 - ■ ■ A 0 ■ - 0 ■ B1
4.00	362	91	2 250	25	1.21	999/250	✓	✓	✓	✓	✓														2KJ3301 - ■ ■ A 0 ■ - 0 ■ A1

1) Only in conjunction with reduced-backlash version

Article No. supplement

Shaft design	→ Page 9/39																								
Adapter size	1 or 9																								
	K4	B	C	D	E	F	G	H	J	K	L	M	N												4
	K2			D	E	F	G	H	J	K	L	M	N	P	Q										2
	KQ	A	B	C		D	E																		7
	K8					A	B		C		D		E	F											8
	K5	A		B	C		D	E		F	G	H													5
	K3	A		B	C		D	E		F	G	H													3
Adapter type																									
Gearbox mounting type	→ Page 9/34 A, B, F or H																								

Selection and ordering data

Gearbox							Adapter													Article No.				
i	n_2	T_{2N}	F_{R2}	ϕ ¹⁾	J_G	R_{ex}	K4	63	71	80	90	100	112	132	160	180	200	225	250				(Article No. supplement → below)	
-	rpm	Nm	N	'	10^{-4}	-	K2			80	90	100	112	132	160	180	200	225	250	280	315			
							KQ	703	704	706			708	710										
							K8						808	810		813		816		818	822			
							K5	56		140	180			210	250		280	320	360					
							K3	56		140	180			210	250		280	320	360					
FD.39																								
274.26	5.3	290	5 820	9 0.04	32637/119		✓	✓																2KJ3402 - ■ ■ A 0 ■ - 0 ■ R1
243.26	6.0	290	5 820	9 0.05	8514/35		✓	✓	✓															2KJ3402 - ■ ■ A 0 ■ - 0 ■ Q1
211.06	6.9	290	5 820	9 0.06	251163/1190		✓	✓	✓															2KJ3402 - ■ ■ A 0 ■ - 0 ■ P1
191.87	7.6	290	5 820	9 0.07	22833/119		✓	✓	✓	✓														2KJ3402 - ■ ■ A 0 ■ - 0 ■ N1
164.56	8.8	290	5 820	9 0.09	97911/595		✓	✓	✓	✓														2KJ3402 - ■ ■ A 0 ■ - 0 ■ M1
149.60	9.7	290	5 820	9 0.11	17802/119		✓	✓	✓	✓														2KJ3402 - ■ ■ A 0 ■ - 0 ■ L1
131.17	11	290	5 820	9 0.12	15609/119		✓	✓	✓	✓	✓	✓												2KJ3402 - ■ ■ A 0 ■ - 0 ■ K1
117.08	12	290	5 820	9 0.15	13932/119		✓	✓	✓	✓	✓	✓	✓											2KJ3402 - ■ ■ A 0 ■ - 0 ■ J1
104.34	14	290	5 820	9 0.18	7095/68		✓	✓	✓	✓	✓	✓	✓											2KJ3402 - ■ ■ A 0 ■ - 0 ■ H1
96.31	15	290	5 820	9 0.21	21285/221		✓	✓	✓	✓	✓	✓	✓											2KJ3402 - ■ ■ A 0 ■ - 0 ■ G1
84.32	17	290	5 820	9 0.25	140481/1666		✓	✓	✓	✓	✓	✓	✓											2KJ3402 - ■ ■ A 0 ■ - 0 ■ F1
73.93	20	290	5 820	9 0.24	43989/595		✓	✓	✓	✓	✓	✓	✓											2KJ3402 - ■ ■ A 0 ■ - 0 ■ E1
67.07	22	290	5 820	9 0.34	63855/952		✓	✓	✓	✓	✓	✓	✓											2KJ3402 - ■ ■ A 0 ■ - 0 ■ D1
63.13	23	290	5 820	9 0.40	127710/2023		✓	✓	✓	✓	✓	✓	✓											2KJ3402 - ■ ■ A 0 ■ - 0 ■ C1
55.65	26	290	5 820	9 0.44	946/17		✓	✓	✓	✓	✓	✓	✓											2KJ3402 - ■ ■ A 0 ■ - 0 ■ B1
48.29	30	290	5 820	9 0.59	114939/2380		✓	✓	✓	✓	✓	✓	✓											2KJ3402 - ■ ■ A 0 ■ - 0 ■ A1

1) Only in conjunction with reduced-backlash version

Article No. supplement		1 or 9																						
Shaft design	→ Page 9/39																							
Adapter size		K4	B	C	D	E	F	G	H	J	K	L	M	N										4
		K2			D	E	F	G	H	J	K	L	M	N	P	Q								2
		KQ		A	B	C		D	E															7
		K8						A	B		C		D		E	F								8
		K5		A		B	C		D	E		F	G	H										5
		K3		A		B	C		D	E		F	G	H										3
Adapter type																								
Gearbox mounting type	→ Page 9/34		A, B, F or H																					

SIMOGEAR Gearboxes

Parallel shaft gearbox

Transmission ratios and torques

Selection and ordering data

Gearbox							Adapter													Article No.						
<i>i</i>	<i>n</i> ₂	<i>T</i> _{2N}	<i>F</i> _{R2}	ϕ ¹⁾	<i>J</i> _G	<i>R</i> _{ex}	K4	63	71	80	90	100	112	132	160	180	200	225	250				(Article No. supplement → below)			
-	rpm	Nm	N	'	10 ⁻⁴	-	K2			80	90	100	112	132	160	180	200	225	250	280	315					
							KQ	703	704	706			708	710												
							K8						808	810		813		816		818	822					
							K5	56		140	180		210	250		280	320	360								
							K3	56		140	180		210	250		280	320	360								
FZ.39																										
65.21	22	290	5 820	9 0.06	913/14		✓	✓																2KJ3302 - ■ ■ A 0 ■ - 0 ■ B2		
57.99	25	230	6 040	9 0.08	4059/70		✓	✓	✓															2KJ3302 - ■ ■ A 0 ■ - 0 ■ A2		
50.91	28	240	6 000	9 0.09	1782/35		✓	✓	✓															2KJ3302 - ■ ■ A 0 ■ - 0 ■ X1		
46.29	31	255	5 950	9 0.11	324/7		✓	✓	✓	✓														2KJ3302 - ■ ■ A 0 ■ - 0 ■ W1		
39.60	37	290	5 820	9 0.13	198/5		✓	✓	✓	✓														2KJ3302 - ■ ■ A 0 ■ - 0 ■ V1		
36.00	40	255	5 950	9 0.16	36/1		✓	✓	✓	✓														2KJ3302 - ■ ■ A 0 ■ - 0 ■ U1		
31.82	46	285	5 490	9 0.19	891/28		✓	✓	✓	✓	✓	✓	✓											2KJ3302 - ■ ■ A 0 ■ - 0 ■ T1		
28.93	50	275	5 330	9 0.26	405/14		✓	✓	✓	✓	✓	✓	✓											2KJ3302 - ■ ■ A 0 ■ - 0 ■ S1		
25.34	57	265	5 080	9 0.30	1419/56		✓	✓	✓	✓	✓	✓	✓											2KJ3302 - ■ ■ A 0 ■ - 0 ■ R1		
23.39	62	260	4 930	9 0.36	4257/182		✓	✓	✓	✓	✓	✓	✓											2KJ3302 - ■ ■ A 0 ■ - 0 ■ Q1		
20.71	70	250	4 740	9 0.42	4059/196		✓	✓	✓	✓	✓	✓	✓											2KJ3302 - ■ ■ A 0 ■ - 0 ■ P1		
17.24	84	235	4 460	9 0.57	3861/224		✓	✓	✓	✓	✓	✓	✓											2KJ3302 - ■ ■ A 0 ■ - 0 ■ N1		
16.22	89	230	4 370	9 0.66	3861/238		✓	✓	✓	✓	✓	✓	✓											2KJ3302 - ■ ■ A 0 ■ - 0 ■ M1		
14.54	100	220	4 220	10 0.74	407/28		✓	✓	✓	✓	✓	✓	✓											2KJ3302 - ■ ■ A 0 ■ - 0 ■ L1		
12.38	117	210	3 990	10 0.97	99/8		✓	✓	✓	✓	✓	✓	✓											2KJ3302 - ■ ■ A 0 ■ - 0 ■ K1		
10.61	137	199	3 800	10 1.28	297/28				✓	✓	✓	✓	✓											2KJ3302 - ■ ■ A 0 ■ - 0 ■ J1		
9.13	159	189	3 610	10 1.65	1023/112				✓	✓	✓	✓	✓											2KJ3302 - ■ ■ A 0 ■ - 0 ■ H1		
8.10	179	167	3 430	14 0.70	3403/420		✓	✓	✓	✓	✓	✓	✓											2KJ3302 - ■ ■ A 0 ■ - 0 ■ G1		
6.74	215	152	3 270	14 0.96	1079/160		✓	✓	✓	✓	✓	✓	✓											2KJ3302 - ■ ■ A 0 ■ - 0 ■ F1		
6.35	228	149	3 210	14 1.11	1079/170		✓	✓	✓	✓	✓	✓	✓											2KJ3302 - ■ ■ A 0 ■ - 0 ■ E1		
5.69	255	140	3 120	15 1.29	3071/540		✓	✓	✓	✓	✓	✓	✓											2KJ3302 - ■ ■ A 0 ■ - 0 ■ D1		
4.84	300	128	3 000	15 1.73	581/120		✓	✓	✓	✓	✓	✓	✓											2KJ3302 - ■ ■ A 0 ■ - 0 ■ C1		
4.15	349	118	2 950	16 2.30	83/20				✓	✓	✓	✓	✓											2KJ3302 - ■ ■ A 0 ■ - 0 ■ B1		
3.57	406	108	2 890	17 3.00	2573/720				✓	✓	✓	✓	✓											2KJ3302 - ■ ■ A 0 ■ - 0 ■ A1		

1) Only in conjunction with reduced-backlash version

Article No. supplement

Shaft design	→ Page 9/39	1 or 9																								
Adapter size	K4	B	C	D	E	F	G	H	J	K	L	M	N												4	
	K2			D	E	F	G	H	J	K	L	M	N	P	Q											2
	KQ		A	B	C		D	E																		7
	K8						A	B		C		D		E	F											8
	K5		A		B	C		D	E		F	G	H													5
Adapter type		K3	A		B	C		D	E		F	G	H												3	
Gearbox mounting type	→ Page 9/34	A, B, F or H																								

Selection and ordering data

Gearbox							Adapter													Article No.						
<i>i</i>	<i>n</i> ₂	<i>T</i> _{2N}	<i>F</i> _{R2}	ϕ ¹⁾	<i>J</i> _G	<i>R</i> _{ex}	K4	63	71	80	90	100	112	132	160	180	200	225	250					(Article No. supplement → below)		
-	rpm	Nm	N	'	10 ⁻⁴	-	K2			80	90	100	112	132	160	180	200	225	250	280	315					
							KQ	703	704	706			708	710												
							K8						808	810		813		816		818	822					
							K5	56		140	180			210	250		280	320	360							
							K3	56		140	180			210	250		280	320	360							
FD.49																										
330.98	4.4	480	7 960	8 0.06	26809/81		✓	✓																	2KJ3403 - ■ ■ A 0 ■ - 0 ■ S1	
294.29	4.9	480	7 960	8 0.07	13243/45		✓	✓	✓																2KJ3403 - ■ ■ A 0 ■ - 0 ■ R1	
258.40	5.6	480	7 960	8 0.08	1292/5		✓	✓	✓																2KJ3403 - ■ ■ A 0 ■ - 0 ■ Q1	
234.91	6.2	480	7 960	8 0.10	2584/11		✓	✓	✓	✓															2KJ3403 - ■ ■ A 0 ■ - 0 ■ P1	
200.98	7.2	480	7 960	8 0.12	9044/45		✓	✓	✓	✓															2KJ3403 - ■ ■ A 0 ■ - 0 ■ N1	
182.71	7.9	480	7 960	8 0.14	18088/99		✓	✓	✓	✓															2KJ3403 - ■ ■ A 0 ■ - 0 ■ M1	
161.50	9	480	7 960	8 0.17	323/2		✓	✓	✓	✓	✓	✓													2KJ3403 - ■ ■ A 0 ■ - 0 ■ L1	
146.82	9.9	480	7 960	8 0.22	1615/11		✓	✓	✓	✓	✓	✓													2KJ3403 - ■ ■ A 0 ■ - 0 ■ K1	
128.60	11	480	7 960	8 0.26	13889/108		✓	✓	✓	✓	✓	✓													2KJ3403 - ■ ■ A 0 ■ - 0 ■ J1	
118.71	12	480	7 960	8 0.31	13889/117		✓	✓	✓	✓	✓	✓													2KJ3403 - ■ ■ A 0 ■ - 0 ■ H1	
105.10	14	480	7 960	8 0.37	13243/126		✓	✓	✓	✓	✓	✓	✓												2KJ3403 - ■ ■ A 0 ■ - 0 ■ G1	
87.48	17	480	7 960	8 0.50	4199/48		✓	✓	✓	✓	✓	✓	✓	✓											2KJ3403 - ■ ■ A 0 ■ - 0 ■ F1	
82.33	18	480	7 960	8 0.59	247/3		✓	✓	✓	✓	✓	✓	✓	✓											2KJ3403 - ■ ■ A 0 ■ - 0 ■ E1	
73.77	20	480	7 640	8 0.66	11951/162		✓	✓	✓	✓	✓	✓	✓	✓											2KJ3403 - ■ ■ A 0 ■ - 0 ■ D1	
62.81	23	480	7 080	8 0.86	2261/36		✓	✓	✓	✓	✓	✓	✓	✓											2KJ3403 - ■ ■ A 0 ■ - 0 ■ C1	
53.83	27	480	6 570	8 1.13	323/6				✓	✓	✓	✓	✓	✓											2KJ3403 - ■ ■ A 0 ■ - 0 ■ B1	
46.36	31	480	6 090	8 1.46	10013/216				✓	✓	✓	✓	✓	✓											2KJ3403 - ■ ■ A 0 ■ - 0 ■ A1	

¹⁾ Only in conjunction with reduced-backlash version

Article No. supplement		1 or 9																							
Shaft design	→ Page 9/39																								
Adapter size		K4	B	C	D	E	F	G	H	J	K	L	M	N											4
		K2			D	E	F	G	H	J	K	L	M	N	P	Q									2
		KQ		A	B	C		D	E																7
		K8						A	B		C		D		E	F									8
		K5		A		B	C		D	E		F	G	H											5
		K3		A		B	C		D	E		F	G	H											3
Adapter type																									
Gearbox mounting type	→ Page 9/34		A, B, F or H																						

SIMOGEAR Gearboxes

Parallel shaft gearbox

Transmission ratios and torques

Selection and ordering data

Gearbox							Adapter													Article No.							
<i>i</i>	<i>n</i> ₂	<i>T</i> _{2N}	<i>F</i> _{R2}	ϕ ¹⁾	<i>J</i> _G	<i>R</i> _{ex}	K4	63	71	80	90	100	112	132	160	180	200	225	250					(Article No. supplement → below)			
-	rpm	Nm	N	'	10 ⁻⁴	-	K2			80	90	100	112	132	160	180	200	225	250	280	315						
							KQ	703	704	706			708	710													
							K8						808	810		813		816		818	822						
							K5	56		140	180			210	250		280	320	360								
							K3	56		140	180			210	250		280	320	360								
FZ.49																											
61.43	24	480	7 000	8 0.18	1843/30		✓	✓	✓																2KJ3303 - ■ ■ A 0 ■ - 0 ■ X1		
55.85	26	480	6 690	8 0.22	1843/33		✓	✓	✓	✓															2KJ3303 - ■ ■ A 0 ■ - 0 ■ W1		
47.50	31	480	6 170	8 0.27	95/2		✓	✓	✓	✓															2KJ3303 - ■ ■ A 0 ■ - 0 ■ V1		
43.18	34	480	5 880	8 0.33	475/11		✓	✓	✓	✓															2KJ3303 - ■ ■ A 0 ■ - 0 ■ U1		
38.53	38	480	5 540	8 0.39	1387/36		✓	✓	✓	✓	✓	✓													2KJ3303 - ■ ■ A 0 ■ - 0 ■ T1		
34.55	42	480	5 230	8 0.47	380/11		✓	✓	✓	✓	✓	✓	✓												2KJ3303 - ■ ■ A 0 ■ - 0 ■ S1		
31.14	47	480	4 950	8 0.55	1121/36		✓	✓	✓	✓	✓	✓	✓												2KJ3303 - ■ ■ A 0 ■ - 0 ■ R1		
28.74	50	480	4 730	8 0.65	1121/39		✓	✓	✓	✓	✓	✓	✓												2KJ3303 - ■ ■ A 0 ■ - 0 ■ Q1		
26.24	55	480	4 500	8 0.77	551/21		✓	✓	✓	✓	✓	✓	✓	✓											2KJ3303 - ■ ■ A 0 ■ - 0 ■ P1		
21.77	67	480	4 040	8 0.99	1045/48		✓	✓	✓	✓	✓	✓	✓	✓											2KJ3303 - ■ ■ A 0 ■ - 0 ■ N1		
20.49	71	480	3 890	8 1.15	1045/51		✓	✓	✓	✓	✓	✓	✓	✓											2KJ3303 - ■ ■ A 0 ■ - 0 ■ M1		
19.35	75	480	3 760	8 1.30	1045/54		✓	✓	✓	✓	✓	✓	✓	✓											2KJ3303 - ■ ■ A 0 ■ - 0 ■ L1		
16.47	88	480	3 400	8 1.61	247/15		✓	✓	✓	✓	✓	✓	✓	✓											2KJ3303 - ■ ■ A 0 ■ - 0 ■ K1		
14.11	103	480	3 070	8 1.99	931/66				✓	✓	✓	✓	✓	✓											2KJ3303 - ■ ■ A 0 ■ - 0 ■ J1		
12.40	117	480	3 010	8 2.50	893/72				✓	✓	✓	✓	✓	✓											2KJ3303 - ■ ■ A 0 ■ - 0 ■ H1		
10.46	139	480	3 140	9 3.10	722/69				✓	✓	✓	✓	✓	✓											2KJ3303 - ■ ■ A 0 ■ - 0 ■ G1		
9.12	159	480	3 210	9 4.20	228/25				✓	✓	✓	✓	✓	✓											2KJ3303 - ■ ■ A 0 ■ - 0 ■ F1		
8.40	173	450	3 010	11 2.20	42/5		✓	✓	✓	✓	✓	✓	✓	✓											2KJ3303 - ■ ■ A 0 ■ - 0 ■ E1		
7.20	201	450	3 070	12 2.80	1029/143				✓	✓	✓	✓	✓	✓											2KJ3303 - ■ ■ A 0 ■ - 0 ■ D1		
6.33	229	430	3 090	12 3.50	329/52				✓	✓	✓	✓	✓	✓											2KJ3303 - ■ ■ A 0 ■ - 0 ■ C1		
5.34	272	400	3 080	12 4.60	1596/299				✓	✓	✓	✓	✓	✓											2KJ3303 - ■ ■ A 0 ■ - 0 ■ B1		
4.65	312	375	3 060	14 6.10	1512/325				✓	✓	✓	✓	✓	✓											2KJ3303 - ■ ■ A 0 ■ - 0 ■ A1		

1) Only in conjunction with reduced-backlash version

Article No. supplement		1 or 9																								
Shaft design	→ Page 9/39																									
Adapter size	K4	B	C	D	E	F	G	H	J	K	L	M	N												4	
	K2			D	E	F	G	H	J	K	L	M	N	P	Q											2
	KQ		A	B	C		D	E																		7
	K8						A	B		C		D		E	F											8
	K5		A		B	C		D	E		F	G	H													5
K3		A		B	C		D	E		F	G	H													3	
Adapter type																										
Gearbox mounting type	→ Page 9/34	A, B, F or H																								

Selection and ordering data

Gearbox							Adapter												Article No.					
i	n_2	T_{2N}	F_{R2}	ϕ ¹⁾	J_G	R_{ex}	K4	63	71	80	90	100	112	132	160	180	200	225	250			(Article No. supplement → below)		
-	rpm	Nm	N	'	10 ⁻⁴	-	K2			80	90	100	112	132	160	180	200	225	250	280	315			
							KQ	703	704	706			708	710										
							K8						808	810		813		816		818	822			
							K5	56		140	180			210	250			280	320	360				
							K3	56		140	180			210	250			280	320	360				
FD.69																								
348.40	4.2	600	10 800	8	0.06	28220/81	✓	✓															2KJ3404 - ■ ■ A 0 ■ - 0 ■ S1	
309.78	4.7	600	10 800	8	0.07	2788/9	✓	✓	✓															2KJ3404 - ■ ■ A 0 ■ - 0 ■ R1
272.00	5.3	600	10 800	8	0.08	272/1	✓	✓	✓															2KJ3404 - ■ ■ A 0 ■ - 0 ■ Q1
247.27	5.9	600	10 800	8	0.10	2720/11	✓	✓	✓	✓														2KJ3404 - ■ ■ A 0 ■ - 0 ■ P1
211.56	6.9	600	10 800	8	0.12	1904/9	✓	✓	✓	✓														2KJ3404 - ■ ■ A 0 ■ - 0 ■ N1
192.32	7.5	600	10 800	8	0.14	19040/99	✓	✓	✓	✓														2KJ3404 - ■ ■ A 0 ■ - 0 ■ M1
170.00	8.5	600	10 800	8	0.17	170/1	✓	✓	✓	✓	✓	✓												2KJ3404 - ■ ■ A 0 ■ - 0 ■ L1
154.55	9.4	600	10 800	8	0.22	1700/11	✓	✓	✓	✓	✓	✓	✓											2KJ3404 - ■ ■ A 0 ■ - 0 ■ K1
135.37	11	600	10 800	8	0.26	3655/27	✓	✓	✓	✓	✓	✓	✓											2KJ3404 - ■ ■ A 0 ■ - 0 ■ J1
124.96	12	600	10 800	8	0.31	14620/117	✓	✓	✓	✓	✓	✓	✓											2KJ3404 - ■ ■ A 0 ■ - 0 ■ H1
110.63	13	600	10 800	8	0.38	6970/63	✓	✓	✓	✓	✓	✓	✓	✓										2KJ3404 - ■ ■ A 0 ■ - 0 ■ G1
92.08	16	600	10 800	8	0.51	1105/12	✓	✓	✓	✓	✓	✓	✓	✓										2KJ3404 - ■ ■ A 0 ■ - 0 ■ F1
86.67	17	600	10 800	8	0.60	260/3	✓	✓	✓	✓	✓	✓	✓	✓										2KJ3404 - ■ ■ A 0 ■ - 0 ■ E1
77.65	19	600	10 400	8	0.66	6290/81	✓	✓	✓	✓	✓	✓	✓	✓										2KJ3404 - ■ ■ A 0 ■ - 0 ■ D1
66.11	22	600	9 740	8	0.87	595/9	✓	✓	✓	✓	✓	✓	✓	✓										2KJ3404 - ■ ■ A 0 ■ - 0 ■ C1
56.67	26	600	9 060	8	1.15	170/3			✓	✓	✓	✓	✓	✓										2KJ3404 - ■ ■ A 0 ■ - 0 ■ B1
48.80	30	600	8 440	8	1.47	2635/54			✓	✓	✓	✓	✓	✓										2KJ3404 - ■ ■ A 0 ■ - 0 ■ A1

¹⁾ Only in conjunction with reduced-backlash version

Article No. supplement

Shaft design

→ Page 9/39

1 or 9

Adapter size

K4	B	C	D	E	F	G	H	J	K	L	M	N											4	
K2			D	E	F	G	H	J	K	L	M	N	P	Q										2
KQ		A	B	C		D	E																	7
K8						A	B		C		D		E	F										8
K5		A		B	C		D	E		F	G	H												5
K3		A		B	C		D	E		F	G	H												3

Adapter type

Gearbox mounting type

→ Page 9/34

A, B, F or H

SIMOGEAR Gearboxes

Parallel shaft gearbox

Transmission ratios and torques

Selection and ordering data

Gearbox							Adapter											Article No.					
<i>i</i>	<i>n</i> ₂	<i>T</i> _{2N}	<i>F</i> _{R2}	ϕ ¹⁾	<i>J</i> _G	<i>R</i> _{ex}	K4	63	71	80	90	100	112	132	160	180	200	225	250			(Article No. supplement → below)	
-	rpm	Nm	N	'	10 ⁻⁴	-	K2			80	90	100	112	132	160	180	200	225	250	280	315		
							KQ	703	704	706		708	710										
							K8					808	810		813		816			818	822		
							K5	56		140	180		210	250		280	320	360					
							K3	56		140	180		210	250		280	320	360					

FZ.69																							
64.67	22	600	9 640	7 0.19	194/3		✓	✓	✓														2KJ3304 - ■ ■ A 0 ■ - 0 ■ X1
58.79	25	600	9 220	7 0.23	1940/33		✓	✓	✓	✓													2KJ3304 - ■ ■ A 0 ■ - 0 ■ W1
50.00	29	600	8 540	7 0.29	50/1		✓	✓	✓	✓													2KJ3304 - ■ ■ A 0 ■ - 0 ■ V1
45.45	32	600	8 160	7 0.35	500/11		✓	✓	✓	✓													2KJ3304 - ■ ■ A 0 ■ - 0 ■ U1
40.56	36	600	7 720	7 0.41	365/9		✓	✓	✓	✓	✓	✓											2KJ3304 - ■ ■ A 0 ■ - 0 ■ T1
36.36	40	600	7 310	7 0.49	400/11		✓	✓	✓	✓	✓	✓	✓										2KJ3304 - ■ ■ A 0 ■ - 0 ■ S1
32.78	44	600	6 930	7 0.58	295/9		✓	✓	✓	✓	✓	✓	✓										2KJ3304 - ■ ■ A 0 ■ - 0 ■ R1
30.26	48	600	6 650	7 0.69	1180/39		✓	✓	✓	✓	✓	✓	✓										2KJ3304 - ■ ■ A 0 ■ - 0 ■ Q1
27.62	52	600	6 340	7 0.83	580/21		✓	✓	✓	✓	✓	✓	✓	✓									2KJ3304 - ■ ■ A 0 ■ - 0 ■ P1
22.92	63	600	5 740	8 1.07	275/12		✓	✓	✓	✓	✓	✓	✓	✓									2KJ3304 - ■ ■ A 0 ■ - 0 ■ N1
21.57	67	600	5 550	8 1.23	1100/51		✓	✓	✓	✓	✓	✓	✓	✓									2KJ3304 - ■ ■ A 0 ■ - 0 ■ M1
20.37	71	600	5 370	8 1.39	550/27		✓	✓	✓	✓	✓	✓	✓	✓									2KJ3304 - ■ ■ A 0 ■ - 0 ■ L1
17.33	84	600	4 900	8 1.74	52/3		✓	✓	✓	✓	✓	✓	✓	✓									2KJ3304 - ■ ■ A 0 ■ - 0 ■ K1
14.85	98	600	4 460	8 2.20	490/33					✓	✓	✓	✓	✓									2KJ3304 - ■ ■ A 0 ■ - 0 ■ J1
13.06	111	600	4 120	8 2.70	235/18					✓	✓	✓	✓	✓									2KJ3304 - ■ ■ A 0 ■ - 0 ■ H1
11.01	132	600	4 030	8 3.50	760/69					✓	✓	✓	✓	✓									2KJ3304 - ■ ■ A 0 ■ - 0 ■ G1
9.60	151	600	4 130	9 4.60	48/5					✓	✓	✓	✓	✓									2KJ3304 - ■ ■ A 0 ■ - 0 ■ F1
8.90	163	475	4 030	11 2.40	89/10		✓	✓	✓	✓	✓	✓	✓	✓									2KJ3304 - ■ ■ A 0 ■ - 0 ■ E1
7.62	190	465	4 100	11 3.10	4361/572					✓	✓	✓	✓	✓									2KJ3304 - ■ ■ A 0 ■ - 0 ■ D1
6.70	216	440	4 120	11 3.90	4183/624					✓	✓	✓	✓	✓									2KJ3304 - ■ ■ A 0 ■ - 0 ■ C1
5.66	256	410	4 110	12 5.10	1691/299					✓	✓	✓	✓	✓									2KJ3304 - ■ ■ A 0 ■ - 0 ■ B1
4.93	294	385	4 070	13 6.80	1602/325					✓	✓	✓	✓	✓									2KJ3304 - ■ ■ A 0 ■ - 0 ■ A1

1) Only in conjunction with reduced-backlash version

Article No. supplement

Shaft design	→ Page 9/39	1 or 9																						
Adapter size	K4	B	C	D	E	F	G	H	J	K	L	M	N											4
	K2			D	E	F	G	H	J	K	L	M	N	P	Q									2
	KQ		A	B	C		D	E																7
	K8						A	B		C		D	E	F										8
	K5		A		B	C		D	E		F	G	H											5
K3		A		B	C		D	E		F	G	H											3	
Adapter type																								
Gearbox mounting type	→ Page 9/34	A, B, F or H																						

Selection and ordering data

Gearbox							Adapter													Article No.						
i	n_2	T_{2N}	F_{R2}	ϕ ¹⁾	J_G	R_{ex}	K4	63	71	80	90	100	112	132	160	180	200	225	250					(Article No. supplement → below)		
-	rpm	Nm	N	'	10 ⁻⁴	-	K2			80	90	100	112	132	160	180	200	225	250	280	315					
							KQ	703	704	706			708	710												
							K8						808	810		813		816		818	822					
							K5	56		140	180		210	250		280	320	360								
							K3	56		140	180		210	250		280	320	360								
FD.79																										
357.00	4.1	1 000	13 600	7	0.17	57133/160		✓	✓															2KJ3405 - ■ ■ A 0 ■ - 0 ■ S1		
324.62	4.5	1 000	13 600	7	0.20	57133/176		✓	✓	✓														2KJ3405 - ■ ■ A 0 ■ - 0 ■ R1		
276.09	5.3	1 000	13 600	7	0.25	8835/32		✓	✓	✓														2KJ3405 - ■ ■ A 0 ■ - 0 ■ Q1		
250.99	5.8	1 000	13 600	7	0.30	44175/176		✓	✓	✓														2KJ3405 - ■ ■ A 0 ■ - 0 ■ P1		
223.94	6.5	1 000	13 600	7	0.35	42997/192		✓	✓	✓	✓	✓												2KJ3405 - ■ ■ A 0 ■ - 0 ■ N1		
200.80	7.2	1 000	13 600	7	0.42	8835/44		✓	✓	✓	✓	✓												2KJ3405 - ■ ■ A 0 ■ - 0 ■ M1		
180.99	8	1 000	13 600	7	0.49	34751/192		✓	✓	✓	✓	✓												2KJ3405 - ■ ■ A 0 ■ - 0 ■ L1		
167.07	8.7	1 000	13 600	7	0.58	34751/208		✓	✓	✓	✓	✓												2KJ3405 - ■ ■ A 0 ■ - 0 ■ K1		
152.51	9.5	1 000	13 600	7	0.69	17081/112		✓	✓	✓	✓	✓	✓	✓										2KJ3405 - ■ ■ A 0 ■ - 0 ■ J1		
126.54	11	1 000	13 600	7	0.87	32395/256		✓	✓	✓	✓	✓	✓	✓	✓									2KJ3405 - ■ ■ A 0 ■ - 0 ■ H1		
119.10	12	1 000	13 600	7	1.01	32395/272		✓	✓	✓	✓	✓	✓	✓	✓									2KJ3405 - ■ ■ A 0 ■ - 0 ■ G1		
112.48	13	1 000	13 600	7	1.15	32395/288		✓	✓	✓	✓	✓	✓	✓	✓									2KJ3405 - ■ ■ A 0 ■ - 0 ■ F1		
95.71	15	1 000	13 600	7	1.39	7657/80		✓	✓	✓	✓	✓	✓	✓	✓									2KJ3405 - ■ ■ A 0 ■ - 0 ■ E1		
81.99	18	1 000	13 600	7	1.70	28861/352				✓	✓	✓	✓	✓	✓									2KJ3405 - ■ ■ A 0 ■ - 0 ■ D1		
72.09	20	1 000	13 600	7	2.10	27683/384				✓	✓	✓	✓	✓	✓									2KJ3405 - ■ ■ A 0 ■ - 0 ■ C1		
60.82	24	1 000	13 600	7	2.60	11191/184				✓	✓	✓	✓	✓	✓									2KJ3405 - ■ ■ A 0 ■ - 0 ■ B1		
53.01	27	1 000	13 600	7	3.50	5301/100				✓	✓	✓	✓	✓	✓									2KJ3405 - ■ ■ A 0 ■ - 0 ■ A1		

¹⁾ Only in conjunction with reduced-backlash version

Article No. supplement		1 or 9																						
Shaft design	→ Page 9/39																							
Adapter size		K4	B	C	D	E	F	G	H	J	K	L	M	N										4
		K2			D	E	F	G	H	J	K	L	M	N	P	Q								2
		KQ		A	B	C		D	E														7	
		K8						A	B		C		D		E	F							8	
		K5		A		B	C		D	E		F	G	H									5	
		K3		A		B	C		D	E		F	G	H									3	
Adapter type																								
Gearbox mounting type	→ Page 9/34		A, B, F or H																					

SIMOGEAR Gearboxes

Parallel shaft gearbox

Transmission ratios and torques

Selection and ordering data

Gearbox							Adapter											Article No.					
i	n_2	T_{2N}	F_{R2}	ϕ ¹⁾	J_G	R_{ex}	K4	63	71	80	90	100	112	132	160	180	200	225	250			(Article No. supplement → below)	
-	rpm	Nm	N	'	10 ⁻⁴	-	K2			80	90	100	112	132	160	180	200	225	250	280	315		
							KQ	703	704	706			708	710									
							K8						808	810		813		816		818	822		
							K5	56		140	180			210	250		280	320	360				
							K3	56		140	180			210	250		280	320	360				

FZ.79

53.55	27	1 000	13 600	7 0.56	589/11		✓	✓	✓													2KJ3305 - ■ ■ A 0 ■ - 0 ■ X1
48.03	30	1 000	13 600	7 0.77	1729/36		✓	✓	✓	✓	✓											2KJ3305 - ■ ■ A 0 ■ - 0 ■ W1
43.18	34	1 000	13 600	7 0.87	475/11		✓	✓	✓	✓	✓											2KJ3305 - ■ ■ A 0 ■ - 0 ■ V1
39.06	37	1 000	13 600	7 0.97	703/18		✓	✓	✓	✓	✓											2KJ3305 - ■ ■ A 0 ■ - 0 ■ U1
36.05	40	1 000	13 600	7 1.15	1406/39		✓	✓	✓	✓	✓											2KJ3305 - ■ ■ A 0 ■ - 0 ■ T1
33.02	44	1 000	13 600	7 1.49	1387/42		✓	✓	✓	✓	✓	✓	✓									2KJ3305 - ■ ■ A 0 ■ - 0 ■ S1
27.71	52	1 000	13 600	7 1.62	665/24		✓	✓	✓	✓	✓	✓	✓	✓								2KJ3305 - ■ ■ A 0 ■ - 0 ■ R1
26.08	56	1 000	13 600	7 1.85	1330/51		✓	✓	✓	✓	✓	✓	✓	✓								2KJ3305 - ■ ■ A 0 ■ - 0 ■ Q1
23.93	61	1 000	13 600	7 2.00	646/27		✓	✓	✓	✓	✓	✓	✓	✓								2KJ3305 - ■ ■ A 0 ■ - 0 ■ P1
20.90	69	1 000	13 600	7 2.90	209/10		✓	✓	✓	✓	✓	✓	✓	✓								2KJ3305 - ■ ■ A 0 ■ - 0 ■ N1
18.71	77	1 000	13 000	7 3.60	1235/66				✓	✓	✓	✓	✓	✓								2KJ3305 - ■ ■ A 0 ■ - 0 ■ M1
16.36	89	1 000	12 200	7 4.20	589/36				✓	✓	✓	✓	✓	✓								2KJ3305 - ■ ■ A 0 ■ - 0 ■ L1
14.04	103	1 000	11 400	7 4.70	323/23				✓	✓	✓	✓	✓	✓								2KJ3305 - ■ ■ A 0 ■ - 0 ■ K1
12.41	117	1 000	10 800	7 6.00	931/75				✓	✓	✓	✓	✓	✓								2KJ3305 - ■ ■ A 0 ■ - 0 ■ J1
10.56	137	1 000	10 100	8 7.80	95/9						✓	✓	✓	✓								2KJ3305 - ■ ■ A 0 ■ - 0 ■ H1
9.05	160	1 000	9 980	8 10.00	190/21						✓	✓	✓	✓								2KJ3305 - ■ ■ A 0 ■ - 0 ■ G1
8.51	170	720	10 300	10 4.60	468/55				✓	✓	✓	✓	✓	✓								2KJ3305 - ■ ■ A 0 ■ - 0 ■ F1
7.44	195	725	9 780	11 5.50	186/25				✓	✓	✓	✓	✓	✓								2KJ3305 - ■ ■ A 0 ■ - 0 ■ E1
6.39	227	720	9 690	11 6.50	3672/575				✓	✓	✓	✓	✓	✓								2KJ3305 - ■ ■ A 0 ■ - 0 ■ D1
5.64	257	700	9 620	12 8.30	3528/625				✓	✓	✓	✓	✓	✓								2KJ3305 - ■ ■ A 0 ■ - 0 ■ C1
4.80	302	650	9 480	12 11.00	24/5						✓	✓	✓	✓								2KJ3305 - ■ ■ A 0 ■ - 0 ■ B1
4.11	353	605	9 310	13 15.00	144/35						✓	✓	✓	✓								2KJ3305 - ■ ■ A 0 ■ - 0 ■ A1

1) Only in conjunction with reduced-backlash version

Article No. supplement

Shaft design	→ Page 9/39	1 or 9																						
Adapter size		K4	B	C	D	E	F	G	H	J	K	L	M	N										4
		K2			D	E	F	G	H	J	K	L	M	N	P	Q								2
		KQ		A	B	C		D	E															7
		K8						A	B		C		D	E	F									8
		K5		A		B	C		D	E		F	G	H										5
		K3		A		B	C		D	E		F	G	H										3
Adapter type																								
Gearbox mounting type	→ Page 9/34																							

Selection and ordering data

Gearbox							Adapter													Article No.				
i	n_2	T_{2N}	F_{R2}	ϕ ¹⁾	J_G	R_{ex}	K4	63	71	80	90	100	112	132	160	180	200	225	250				(Article No. supplement → below)	
-	rpm	Nm	N	'	10 ⁻⁴ kgm ²	-	K2			80	90	100	112	132	160	180	200	225	250	280	315			
							KQ	703	704	706			708	710										
							K8						808	810		813		816		818	822			
							K5	56		140	180			210	250			280	320	360				
							K3	56		140	180			210	250			280	320	360				
FD.89																								
335.30	4.3	1 850	17 400	7	0.42	370512/1105			✓	✓														2KJ3406 - ■ ■ A 0 ■ - 0 ■ S1
304.82	4.8	1 850	17 400	7	0.51	741024/2431			✓	✓														2KJ3406 - ■ ■ A 0 ■ - 0 ■ R1
273.41	5.3	1 850	17 400	7	0.71	4648/17			✓	✓	✓	✓												2KJ3406 - ■ ■ A 0 ■ - 0 ■ Q1
245.82	5.9	1 850	17 400	7	0.79	597600/2431			✓	✓	✓	✓												2KJ3406 - ■ ■ A 0 ■ - 0 ■ P1
222.33	6.5	1 850	17 400	7	0.88	49136/221			✓	✓	✓	✓												2KJ3406 - ■ ■ A 0 ■ - 0 ■ N1
205.23	7.1	1 850	17 400	7	1.03	589632/2873			✓	✓	✓	✓												2KJ3406 - ■ ■ A 0 ■ - 0 ■ M1
188.00	7.7	1 850	17 400	7	1.35	290832/1547			✓	✓	✓	✓	✓	✓	✓									2KJ3406 - ■ ■ A 0 ■ - 0 ■ L1
157.74	9.2	1 850	17 400	7	1.43	34860/221			✓	✓	✓	✓	✓	✓	✓									2KJ3406 - ■ ■ A 0 ■ - 0 ■ K1
148.46	9.8	1 850	17 400	7	1.64	557760/3757			✓	✓	✓	✓	✓	✓	✓									2KJ3406 - ■ ■ A 0 ■ - 0 ■ J1
136.21	11	1 850	17 400	7	1.79	5312/39			✓	✓	✓	✓	✓	✓	✓									2KJ3406 - ■ ■ A 0 ■ - 0 ■ H1
118.98	12	1 850	17 400	7	2.60	131472/1105			✓	✓	✓	✓	✓	✓	✓									2KJ3406 - ■ ■ A 0 ■ - 0 ■ G1
106.52	14	1 850	17 400	7	3.10	19920/187			✓	✓	✓	✓	✓	✓	✓									2KJ3406 - ■ ■ A 0 ■ - 0 ■ F1
93.14	16	1 850	17 400	7	3.70	20584/221			✓	✓	✓	✓	✓	✓	✓									2KJ3406 - ■ ■ A 0 ■ - 0 ■ E1
79.95	18	1 850	17 400	7	4.00	23904/299			✓	✓	✓	✓	✓	✓	✓									2KJ3406 - ■ ■ A 0 ■ - 0 ■ D1
70.67	21	1 850	17 400	7	5.10	390432/5525			✓	✓	✓	✓	✓	✓	✓									2KJ3406 - ■ ■ A 0 ■ - 0 ■ C1
60.09	24	1 850	17 400	7	6.50	13280/221					✓	✓	✓	✓										2KJ3406 - ■ ■ A 0 ■ - 0 ■ B1
51.51	28	1 850	17 400	7	8.50	79680/1547					✓	✓	✓	✓										2KJ3406 - ■ ■ A 0 ■ - 0 ■ A1

¹⁾ Only in conjunction with reduced-backlash version

Article No. supplement		1 or 9																						
Shaft design	→ Page 9/39																							
Adapter size		K4	B	C	D	E	F	G	H	J	K	L	M	N										4
		K2			D	E	F	G	H	J	K	L	M	N	P	Q								2
		KQ		A	B	C		D	E															7
		K8						A	B		C		D		E	F								8
		K5		A		B	C		D	E		F	G	H										5
		K3		A		B	C		D	E		F	G	H										3
Adapter type																								
Gearbox mounting type	→ Page 9/34																							
			A, B, F or H																					

SIMOGEAR Gearboxes

Parallel shaft gearbox

Transmission ratios and torques

Selection and ordering data

Gearbox							Adapter													Article No.						
<i>i</i>	<i>n</i> ₂	<i>T</i> _{2N}	<i>F</i> _{R2}	ϕ ¹⁾	<i>J</i> _G	<i>R</i> _{ex}	K4	63	71	80	90	100	112	132	160	180	200	225	250					(Article No. supplement → below)		
-	rpm	Nm	N	'	10 ⁻⁴	-	K2			80	90	100	112	132	160	180	200	225	250	280	315					
							KQ	703	704	706		708	710													
							K8					808	810		813		816		818	822						
							K5	56		140	180		210	250		280	320	360								
							K3	56		140	180		210	250		280	320	360								
FZ.89																										
61.72	23	1 850	17 400	6	1.38	2407/39				✓	✓	✓	✓											2KJ3306 - ■ ■ A 0 ■ - 0 ■ B2		
55.72	26	1 850	17 400	6	1.51	7968/143				✓	✓	✓	✓											2KJ3306 - ■ ■ A 0 ■ - 0 ■ A2		
50.54	29	1 850	17 400	6	1.77	7885/156				✓	✓	✓	✓											2KJ3306 - ■ ■ A 0 ■ - 0 ■ X1		
46.66	31	1 850	17 400	6	2.1	7885/169				✓	✓	✓	✓											2KJ3306 - ■ ■ A 0 ■ - 0 ■ W1		
42.41	34	1 850	17 400	6	2.4	7719/182				✓	✓	✓	✓	✓	✓									2KJ3306 - ■ ■ A 0 ■ - 0 ■ V1		
35.91	40	1 850	17 400	7	2.9	3735/104				✓	✓	✓	✓	✓	✓									2KJ3306 - ■ ■ A 0 ■ - 0 ■ U1		
33.80	43	1 850	17 400	7	3.0	7470/221				✓	✓	✓	✓	✓	✓									2KJ3306 - ■ ■ A 0 ■ - 0 ■ T1		
31.21	46	1 850	17 400	7	4.5	3652/117				✓	✓	✓	✓	✓	✓									2KJ3306 - ■ ■ A 0 ■ - 0 ■ S1		
27.77	52	1 850	17 400	7	5.5	7221/260				✓	✓	✓	✓	✓	✓									2KJ3306 - ■ ■ A 0 ■ - 0 ■ R1		
24.67	59	1 850	17 400	7	6.7	7055/286				✓	✓	✓	✓	✓	✓									2KJ3306 - ■ ■ A 0 ■ - 0 ■ Q1		
22.08	66	1 850	17 400	7	6.7	6889/312				✓	✓	✓	✓	✓	✓									2KJ3306 - ■ ■ A 0 ■ - 0 ■ P1		
18.88	77	1 850	17 200	7	7.9	5644/299				✓	✓	✓	✓	✓	✓									2KJ3306 - ■ ■ A 0 ■ - 0 ■ N1		
16.86	86	1 850	16 400	7	10	5478/325			✓	✓	✓	✓	✓	✓	✓	✓								2KJ3306 - ■ ■ A 0 ■ - 0 ■ M1		
14.90	97	1 850	15 500	7	12	581/39					✓	✓	✓	✓	✓									2KJ3306 - ■ ■ A 0 ■ - 0 ■ L1		
13.07	111	1 850	14 600	7	16	3569/273					✓	✓	✓	✓	✓									2KJ3306 - ■ ■ A 0 ■ - 0 ■ K1		
11.38	127	1 850	14 600	7	20	3403/299					✓	✓	✓	✓	✓									2KJ3306 - ■ ■ A 0 ■ - 0 ■ J1		
9.73	149	1 850	14 600	7	26	2656/273					✓	✓	✓	✓	✓									2KJ3306 - ■ ■ A 0 ■ - 0 ■ H1		
8.33	174	1 740	14 500	7	33	2490/299					✓	✓	✓	✓	✓									2KJ3306 - ■ ■ A 0 ■ - 0 ■ G1		
7.60	191	1 100	14 100	11	14	4752/625			✓	✓	✓	✓	✓	✓	✓									2KJ3306 - ■ ■ A 0 ■ - 0 ■ F1		
6.72	216	1 110	14 000	12	17	168/25					✓	✓	✓	✓	✓									2KJ3306 - ■ ■ A 0 ■ - 0 ■ E1		
5.90	246	1 110	13 800	11	23	1032/175					✓	✓	✓	✓	✓									2KJ3306 - ■ ■ A 0 ■ - 0 ■ D1		
5.13	283	1 110	13 600	11	28	2952/575					✓	✓	✓	✓	✓									2KJ3306 - ■ ■ A 0 ■ - 0 ■ C1		
4.39	330	1 060	13 300	12	39	768/175					✓	✓	✓	✓	✓									2KJ3306 - ■ ■ A 0 ■ - 0 ■ B1		
3.76	386	985	12 900	12	50	432/115					✓	✓	✓	✓	✓									2KJ3306 - ■ ■ A 0 ■ - 0 ■ A1		

¹⁾ Only in conjunction with reduced-backlash version

Article No. supplement

Shaft design → Page 9/39

Adapter size

1 or 9

K4	B	C	D	E	F	G	H	J	K	L	M	N												4	
K2			D	E	F	G	H	J	K	L	M	N	P	Q											2
KQ	A	B	C		D	E																			7
K8					A	B		C		D		E	F												8
K5	A		B	C		D	E		F	G	H														5
K3	A		B	C		D	E		F	G	H														3

Adapter type

Gearbox mounting type → Page 9/34

A, B, F or H

Selection and ordering data

Gearbox							Adapter													Article No.						
<i>i</i>	<i>n</i> ₂	<i>T</i> _{2N}	<i>F</i> _{R2}	ϕ ¹⁾	<i>J</i> _G	<i>R</i> _{ex}	K4	63	71	80	90	100	112	132	160	180	200	225	250					(Article No. supplement → below)		
-	rpm	Nm	N	'	10 ⁻⁴	-	K2			80	90	100	112	132	160	180	200	225	250	280	315					
							KQ	703	704	706		708	710													
							K8					808	810		813		816			818	822					
							K5	56		140	180		210	250		280	320	360								
							K3	56		140	180		210	250		280	320	360								
FD.109																										
410.00	3.5	3 100	25 000	- 1.27	332021/810						✓	✓	✓												2KJ3407 - ■ ■ A 0 ■ - 0 ■ T1	
370.00	3.9	3 100	25 000	- 1.37	183184/495						✓	✓	✓												2KJ3407 - ■ ■ A 0 ■ - 0 ■ S1	
335.70	4.3	3 100	25 000	- 1.61	217531/648						✓	✓	✓												2KJ3407 - ■ ■ A 0 ■ - 0 ■ R1	
309.87	4.7	3 100	25 000	- 1.89	217531/702						✓	✓	✓												2KJ3407 - ■ ■ A 0 ■ - 0 ■ Q1	
281.68	5.1	3 100	25 000	- 2.2	354919/1260						✓	✓	✓	✓	✓										2KJ3407 - ■ ■ A 0 ■ - 0 ■ P1	
238.52	6.1	3 100	25 000	- 2.6	11449/48						✓	✓	✓	✓	✓										2KJ3407 - ■ ■ A 0 ■ - 0 ■ N1	
224.49	6.5	3 100	25 000	- 2.6	11449/51						✓	✓	✓	✓	✓										2KJ3407 - ■ ■ A 0 ■ - 0 ■ M1	
207.31	7	3 100	25 000	- 4.0	251878/1215						✓	✓	✓	✓	✓										2KJ3407 - ■ ■ A 0 ■ - 0 ■ L1	
184.46	7.9	3 100	25 000	- 5.0	332021/1800						✓	✓	✓	✓	✓										2KJ3407 - ■ ■ A 0 ■ - 0 ■ K1	
163.83	8.9	3 100	25 000	- 5.9	194633/1188						✓	✓	✓	✓	✓										2KJ3407 - ■ ■ A 0 ■ - 0 ■ J1	
146.65	9.9	3 100	25 000	- 5.9	950267/6480						✓	✓	✓	✓	✓										2KJ3407 - ■ ■ A 0 ■ - 0 ■ H1	
125.37	12	3 100	25 000	- 6.7	389266/3105						✓	✓	✓	✓	✓										2KJ3407 - ■ ■ A 0 ■ - 0 ■ G1	
111.95	13	3 100	25 000	- 8.6	125939/1125						✓	✓	✓	✓	✓										2KJ3407 - ■ ■ A 0 ■ - 0 ■ F1	
98.94	15	3 100	25 000	- 9.6	80143/810							✓	✓	✓	✓										2KJ3407 - ■ ■ A 0 ■ - 0 ■ E1	
86.83	17	3 100	25 000	- 14	492307/5670							✓	✓	✓	✓										2KJ3407 - ■ ■ A 0 ■ - 0 ■ D1	
75.59	19	3 100	25 000	- 16	469409/6210							✓	✓	✓	✓										2KJ3407 - ■ ■ A 0 ■ - 0 ■ C1	
64.62	22	3 100	25 000	- 21	183184/2835							✓	✓	✓	✓										2KJ3407 - ■ ■ A 0 ■ - 0 ■ B1	
55.31	26	3 100	25 000	- 25	11449/207							✓	✓	✓	✓										2KJ3407 - ■ ■ A 0 ■ - 0 ■ A1	

1) Only in conjunction with reduced-backlash version

Article No. supplement		1 or 9																								
Shaft design	→ Page 9/39																									
Adapter size		K4	B	C	D	E	F	G	H	J	K	L	M	N											4	
		K2			D	E	F	G	H	J	K	L	M	N	P	Q										2
		KQ	A	B	C		D	E																		7
		K8					A	B		C		D		E	F											8
		K5	A		B	C		D	E		F	G	H													5
		K3	A		B	C		D	E		F	G	H													3
Adapter type																										
Gearbox mounting type	→ Page 9/34	A, B, F or H																								



SIMOGEAR Gearboxes

Parallel shaft gearbox

Transmission ratios and torques

Selection and ordering data

Gearbox							Adapter													Article No.						
<i>i</i>	<i>n</i> ₂	<i>T</i> _{2N}	<i>F</i> _{R2}	ϕ ¹⁾	<i>J</i> _G	<i>R</i> _{ex}	K4	63	71	80	90	100	112	132	160	180	200	225	250					(Article No. supplement → below)		
-	rpm	Nm	N	'	10 ⁻⁴	-	K2			80	90	100	112	132	160	180	200	225	250	280	315					
							KQ	703	704	706			708	710												
							K8						808	810		813		816		818	822					
							K5	56		140	180			210	250		280	320	360							
							K3	56		140	180			210	250		280	320	360							
FZ.109																										
70.74	20	3 100	25 000	-	3.6	12733/180						✓	✓	✓										2KJ3307 - ■ ■ A 0 ■ - 0 ■ B2		
65.30	22	3 100	25 000	-	4.3	12733/195						✓	✓	✓										2KJ3307 - ■ ■ A 0 ■ - 0 ■ A2		
60.12	24	3 100	25 000	-	4.9	6313/105						✓	✓	✓	✓	✓								2KJ3307 - ■ ■ A 0 ■ - 0 ■ X1		
51.27	28	3 100	25 000	-	6.3	2461/48						✓	✓	✓	✓	✓								2KJ3307 - ■ ■ A 0 ■ - 0 ■ W1		
48.25	30	3 100	25 000	-	7.1	2461/51						✓	✓	✓	✓	✓								2KJ3307 - ■ ■ A 0 ■ - 0 ■ V1		
44.78	32	3 100	25 000	-	7.8	12091/270						✓	✓	✓	✓	✓								2KJ3307 - ■ ■ A 0 ■ - 0 ■ U1		
39.59	37	3 100	25 000	-	9.5	3959/100						✓	✓	✓	✓	✓								2KJ3307 - ■ ■ A 0 ■ - 0 ■ T1		
35.34	41	3 100	24 700	-	11	11663/330						✓	✓	✓	✓	✓								2KJ3307 - ■ ■ A 0 ■ - 0 ■ S1		
31.80	46	3 100	23 600	-	13	11449/360						✓	✓	✓	✓	✓								2KJ3307 - ■ ■ A 0 ■ - 0 ■ R1		
27.60	53	3 100	22 200	-	16	9523/345						✓	✓	✓	✓	✓								2KJ3307 - ■ ■ A 0 ■ - 0 ■ Q1		
24.82	58	3 100	21 200	-	19	3103/125						✓	✓	✓	✓	✓	✓							2KJ3307 - ■ ■ A 0 ■ - 0 ■ P1		
21.70	67	3 100	20 000	-	23	7811/360							✓	✓	✓	✓	✓	✓						2KJ3307 - ■ ■ A 0 ■ - 0 ■ N1		
19.36	75	3 100	18 900	-	27	2033/105							✓	✓	✓	✓	✓	✓	✓					2KJ3307 - ■ ■ A 0 ■ - 0 ■ M1		
17.06	85	3 100	17 900	-	33	1177/69							✓	✓	✓	✓	✓	✓	✓					2KJ3307 - ■ ■ A 0 ■ - 0 ■ L1		
14.95	97	3 100	16 800	-	40	4708/315							✓	✓	✓	✓	✓	✓	✓					2KJ3307 - ■ ■ A 0 ■ - 0 ■ K1		
13.03	111	3 100	15 700	-	48	1498/115							✓	✓	✓	✓	✓	✓	✓					2KJ3307 - ■ ■ A 0 ■ - 0 ■ J1		
11.89	122	3 060	15 600	-	56	107/9							✓	✓	✓	✓	✓	✓	✓					2KJ3307 - ■ ■ A 0 ■ - 0 ■ H1		
10.23	142	2 880	15 900	-	70	1177/115								✓	✓	✓	✓	✓	✓					2KJ3307 - ■ ■ A 0 ■ - 0 ■ G1		
9.02	161	2 090	16 100	-	36	1767/196							✓	✓	✓	✓	✓	✓	✓					2KJ3307 - ■ ■ A 0 ■ - 0 ■ F1		
7.94	183	2 000	15 800	-	44	5115/644							✓	✓	✓	✓	✓	✓	✓					2KJ3307 - ■ ■ A 0 ■ - 0 ■ E1		
6.96	208	1 900	15 700	-	54	341/49							✓	✓	✓	✓	✓	✓	✓					2KJ3307 - ■ ■ A 0 ■ - 0 ■ D1		
6.07	239	1 800	15 600	-	68	279/46							✓	✓	✓	✓	✓	✓	✓					2KJ3307 - ■ ■ A 0 ■ - 0 ■ C1		
5.54	262	1 730	15 400	-	79	155/28							✓	✓	✓	✓	✓	✓	✓					2KJ3307 - ■ ■ A 0 ■ - 0 ■ B1		
4.77	304	1 620	15 200	-	102	3069/644								✓	✓	✓	✓	✓	✓					2KJ3307 - ■ ■ A 0 ■ - 0 ■ A1		

1) Only in conjunction with reduced-backlash version

Article No. supplement

Shaft design	→ Page 9/39													1 or 9											
Adapter size	K4	B	C	D	E	F	G	H	J	K	L	M	N											4	
	K2			D	E	F	G	H	J	K	L	M	N	P	Q										2
	KQ		A	B	C		D	E																	7
	K8						A	B		C		D		E	F										8
	K5		A		B	C		D	E		F	G	H												5
	K3		A		B	C		D	E		F	G	H												3
Adapter type																									
Gearbox mounting type	→ Page 9/34													A, B, F or H											

Selection and ordering data

Gearbox							Adapter											Article No.					
i	n_2	T_{2N}	F_{R2}	ϕ ¹⁾	J_G	R_{ex}	K4	63	71	80	90	100	112	132	160	180	200	225	250			(Article No. supplement → below)	
-	rpm	Nm	N	'	10^{-4}	-	K2			80	90	100	112	132	160	180	200	225	250	280	315		
					kgm^2		KQ	703	704	706			708	710									
							K8						808	810		813		816		818	822		
							K5	56		140	180			210	250		280	320	360				
							K3	56		140	180			210	250		280	320	360				
FD.129																							
413.00	3.5	4 850	37 200	-	3.3	9911/24						✓	✓	✓									2KJ3408 - ■ ■ A 0 ■ - 0 ■ T1
381.00	3.8	4 850	37 200	-	3.9	9911/26						✓	✓	✓									2KJ3408 - ■ ■ A 0 ■ - 0 ■ S1
351.00	4.1	4 850	37 200	-	4.5	34397/98						✓	✓	✓	✓	✓							2KJ3408 - ■ ■ A 0 ■ - 0 ■ R1
299.31	4.8	4 850	37 200	-	5.6	67045/224						✓	✓	✓	✓	✓							2KJ3408 - ■ ■ A 0 ■ - 0 ■ Q1
281.70	5.1	4 850	37 200	-	6.4	67045/238						✓	✓	✓	✓	✓							2KJ3408 - ■ ■ A 0 ■ - 0 ■ P1
261.42	5.5	4 850	37 200	-	6.9	65879/252						✓	✓	✓	✓	✓							2KJ3408 - ■ ■ A 0 ■ - 0 ■ N1
231.12	6.3	4 850	37 200	-	8.4	64713/280						✓	✓	✓	✓	✓							2KJ3408 - ■ ■ A 0 ■ - 0 ■ M1
206.32	7	4 850	37 200	-	10	5777/28						✓	✓	✓	✓	✓							2KJ3408 - ■ ■ A 0 ■ - 0 ■ L1
185.66	7.8	4 850	37 200	-	12	62381/336						✓	✓	✓	✓	✓							2KJ3408 - ■ ■ A 0 ■ - 0 ■ K1
161.14	9	4 850	37 200	-	14	51887/322						✓	✓	✓	✓	✓							2KJ3408 - ■ ■ A 0 ■ - 0 ■ J1
144.92	10	4 850	37 200	-	16	50721/350						✓	✓	✓	✓	✓							2KJ3408 - ■ ■ A 0 ■ - 0 ■ H1
126.66	11	4 850	37 200	-	19	42559/336						✓	✓	✓	✓								2KJ3408 - ■ ■ A 0 ■ - 0 ■ G1
113.03	13	4 850	37 200	-	23	11077/98						✓	✓	✓	✓								2KJ3408 - ■ ■ A 0 ■ - 0 ■ F1
99.58	15	4 850	37 200	-	27	32065/322						✓	✓	✓	✓								2KJ3408 - ■ ■ A 0 ■ - 0 ■ E1
87.25	17	4 850	37 200	-	32	12826/147						✓	✓	✓	✓								2KJ3408 - ■ ■ A 0 ■ - 0 ■ D1
76.04	19	4 850	37 200	-	37	1749/23						✓	✓	✓	✓								2KJ3408 - ■ ■ A 0 ■ - 0 ■ C1
69.40	21	4 850	37 200	-	44	2915/42						✓	✓	✓	✓								2KJ3408 - ■ ■ A 0 ■ - 0 ■ B1
59.75	24	4 850	37 200	-	53	19239/322								✓	✓								2KJ3408 - ■ ■ A 0 ■ - 0 ■ A1

1) Only in conjunction with reduced-backlash version

Article No. supplement

Shaft design	→ Page 9/39	1 or 9																						
Adapter size		K4	B	C	D	E	F	G	H	J	K	L	M	N										4
		K2			D	E	F	G	H	J	K	L	M	N	P	Q								2
		KQ	A	B	C			D	E															7
		K8						A	B		C		D		E	F								8
		K5	A		B	C			D	E		F	G	H										5
		K3	A		B	C			D	E		F	G	H										3
Adapter type																								
Gearbox mounting type	→ Page 9/34		A, B, F or H																					

SIMOGEAR Gearboxes

Parallel shaft gearbox

Transmission ratios and torques**Selection and ordering data**

Gearbox							Adapter												Article No.					
i	n_2	T_{2N}	F_{R2}	ϕ ¹⁾	J_G	R_{ex}	K4	63	71	80	90	100	112	132	160	180	200	225	250					(Article No. supplement → below)
-	rpm	Nm	N	'	10^{-4}	-	K2			80	90	100	112	132	160	180	200	225	250	280	315			
							KQ	703	704	706		708	710											
							K8					808	810		813		816			818	822			
							K5	56		140	180		210	250		280	320	360						
							K3	56		140	180		210	250		280	320	360						

FZ.129

69.20	21	4 850	37 200	- 7.7	13563/196		✓	✓	✓	✓	✓												2KJ3308 - ■ A 0 ■ - 0 ■ A2
59.22	24	4 850	37 200	- 9.7	6633/112		✓	✓	✓	✓	✓												2KJ3308 - ■ A 0 ■ - 0 ■ X1
55.74	26	4 850	37 200	- 11	6633/119		✓	✓	✓	✓	✓												2KJ3308 - ■ A 0 ■ - 0 ■ W1
52.25	28	4 850	36 700	- 12	209/4		✓	✓	✓	✓	✓												2KJ3308 - ■ A 0 ■ - 0 ■ V1
46.32	31	4 850	34 900	- 15	12969/280		✓	✓	✓	✓	✓												2KJ3308 - ■ A 0 ■ - 0 ■ U1
41.14	35	4 850	33 200	- 18	288/7		✓	✓	✓	✓	✓												2KJ3308 - ■ A 0 ■ - 0 ■ T1
37.12	39	4 850	31 800	- 21	297/8		✓	✓	✓	✓	✓												2KJ3308 - ■ A 0 ■ - 0 ■ S1
32.90	44	4 850	30 100	- 26	10593/322		✓	✓	✓	✓	✓												2KJ3308 - ■ A 0 ■ - 0 ■ R1
29.13	50	4 850	28 600	- 29	10197/350		✓	✓	✓	✓	✓	✓											2KJ3308 - ■ A 0 ■ - 0 ■ Q1
25.93	56	4 850	27 100	- 35	363/14				✓	✓	✓	✓	✓	✓	✓								2KJ3308 - ■ A 0 ■ - 0 ■ P1
23.23	62	4 850	25 800	- 41	2277/98				✓	✓	✓	✓	✓	✓	✓	✓							2KJ3308 - ■ A 0 ■ - 0 ■ N1
20.60	70	4 850	24 400	- 49	6633/322				✓	✓	✓	✓	✓	✓	✓	✓							2KJ3308 - ■ A 0 ■ - 0 ■ M1
18.18	80	4 850	23 000	- 60	891/49				✓	✓	✓	✓	✓	✓	✓	✓	✓						2KJ3308 - ■ A 0 ■ - 0 ■ L1
15.99	91	4 800	21 800	- 73	2574/161				✓	✓	✓	✓	✓	✓	✓	✓	✓	✓					2KJ3308 - ■ A 0 ■ - 0 ■ K1
14.48	100	4 690	21 100	- 83	1419/98				✓	✓	✓	✓	✓	✓	✓	✓	✓	✓					2KJ3308 - ■ A 0 ■ - 0 ■ J1
12.61	115	4 530	20 100	- 101	4059/322						✓	✓	✓	✓	✓	✓	✓	✓					2KJ3308 - ■ A 0 ■ - 0 ■ H1
10.34	140	4 320	20 400	- 135	1881/182						✓	✓	✓	✓	✓	✓	✓	✓					2KJ3308 - ■ A 0 ■ - 0 ■ G1
9.80	148	3 630	19 600	- 64	2479/253				✓	✓	✓	✓	✓	✓	✓	✓	✓						2KJ3308 - ■ A 0 ■ - 0 ■ F1
8.65	168	3 640	19 700	- 79	666/77				✓	✓	✓	✓	✓	✓	✓	✓	✓	✓					2KJ3308 - ■ A 0 ■ - 0 ■ E1
7.60	191	3 620	19 800	- 97	1924/253				✓	✓	✓	✓	✓	✓	✓	✓	✓	✓					2KJ3308 - ■ A 0 ■ - 0 ■ D1
6.89	210	3 630	19 700	- 112	1591/231				✓	✓	✓	✓	✓	✓	✓	✓	✓	✓					2KJ3308 - ■ A 0 ■ - 0 ■ C1
6.00	242	3 640	19 600	- 140	1517/253						✓	✓	✓	✓	✓	✓	✓						2KJ3308 - ■ A 0 ■ - 0 ■ B1
4.92	295	3 030	19 300	- 192	703/143						✓	✓	✓	✓	✓	✓	✓						2KJ3308 - ■ A 0 ■ - 0 ■ A1

1) Only in conjunction with reduced-backlash version

Article No. supplement

Shaft design	→ Page 9/39		1 or 9																						
Adapter size	K4	B	C	D	E	F	G	H	J	K	L	M	N											4	
	K2			D	E	F	G	H	J	K	L	M	N	P	Q										2
	KQ	A	B	C		D	E																	7	
	K8					A	B		C		D		E	F										8	
	K5	A		B	C		D	E		F	G	H												5	
K3	A		B	C		D	E		F	G	H												3		
Adapter type																									
Gearbox mounting type	→ Page 9/34		A, B, F or H																						

Selection and ordering data

Gearbox							Adapter													Article No.				
<i>i</i>	<i>n</i> ₂	<i>T</i> _{2N}	<i>F</i> _{R2}	ϕ ¹⁾	<i>J</i> _G	<i>R</i> _{ex}	K4	63	71	80	90	100	112	132	160	180	200	225	250				(Article No. supplement → below)	
-	rpm	Nm	N	'	10 ⁻⁴	-	K2			80	90	100	112	132	160	180	200	225	250	280	315			
							KQ	703	704	706		708	710											
							K8					808	810		813		816		818	822				
							K5	56		140	180		210	250		280	320	360						
							K3	56		140	180		210	250		280	320	360						
FD.149																								
377.00	3.8	8 000	65 000	-	7.1	18495/49							✓	✓	✓	✓								2KJ3410 - ■ ■ A 0 ■ - 0 ■ W1
323.04	4.5	8 000	65 000	-	9	9045/28							✓	✓	✓	✓								2KJ3410 - ■ ■ A 0 ■ - 0 ■ V1
304.03	4.8	8 000	65 000	-	10	36180/119							✓	✓	✓	✓								2KJ3410 - ■ ■ A 0 ■ - 0 ■ U1
285.00	5.1	8 000	65 000	-	11	285/1							✓	✓	✓	✓								2KJ3410 - ■ ■ A 0 ■ - 0 ■ T1
252.64	5.7	8 000	65 000	-	14	3537/14							✓	✓	✓	✓								2KJ3410 - ■ ■ A 0 ■ - 0 ■ S1
224.42	6.5	8 000	65 000	-	16	17280/77							✓	✓	✓	✓								2KJ3410 - ■ ■ A 0 ■ - 0 ■ R1
202.50	7.2	8 000	65 000	-	19	405/2							✓	✓	✓	✓								2KJ3410 - ■ ■ A 0 ■ - 0 ■ Q1
179.44	8.1	8 000	65 000	-	23	28890/161							✓	✓	✓	✓								2KJ3410 - ■ ■ A 0 ■ - 0 ■ P1
158.91	9.1	8 000	65 000	-	26	5562/35							✓	✓	✓	✓	✓							2KJ3410 - ■ ■ A 0 ■ - 0 ■ N1
141.43	10	8 000	65 000	-	31	990/7							✓	✓	✓	✓	✓	✓						2KJ3410 - ■ ■ A 0 ■ - 0 ■ M1
126.73	11	8 000	63 700	-	37	6210/49							✓	✓	✓	✓	✓	✓	✓					2KJ3410 - ■ ■ A 0 ■ - 0 ■ L1
112.36	13	8 000	60 800	-	43	18090/161							✓	✓	✓	✓	✓	✓	✓					2KJ3410 - ■ ■ A 0 ■ - 0 ■ K1
99.18	15	8 000	57 800	-	53	4860/49							✓	✓	✓	✓	✓	✓	✓	✓				2KJ3410 - ■ ■ A 0 ■ - 0 ■ J1
87.20	17	8 000	54 800	-	63	14040/161							✓	✓	✓	✓	✓	✓	✓	✓				2KJ3410 - ■ ■ A 0 ■ - 0 ■ H1
78.98	18	8 000	52 600	-	71	3870/49							✓	✓	✓	✓	✓	✓	✓	✓				2KJ3410 - ■ ■ A 0 ■ - 0 ■ G1
68.76	21	8 000	49 700	-	85	11070/161								✓	✓	✓	✓	✓	✓	✓				2KJ3410 - ■ ■ A 0 ■ - 0 ■ F1
56.37	26	8 000	45 600	-	111	5130/91								✓	✓	✓	✓	✓	✓	✓				2KJ3410 - ■ ■ A 0 ■ - 0 ■ E1
50.01	29	8 000	43 300	-	73	37960/759							✓	✓	✓	✓	✓	✓	✓	✓				2KJ3410 - ■ ■ A 0 ■ - 0 ■ D1
45.30	32	8 000	41 500	-	83	31390/693							✓	✓	✓	✓	✓	✓	✓	✓				2KJ3410 - ■ ■ A 0 ■ - 0 ■ C1
39.43	37	7 970	39 000	-	102	29930/759								✓	✓	✓	✓	✓	✓	✓				2KJ3410 - ■ ■ A 0 ■ - 0 ■ B1
32.33	45	7 510	36 800	-	135	13870/429								✓	✓	✓	✓	✓	✓	✓				2KJ3410 - ■ ■ A 0 ■ - 0 ■ A1

1) Only in conjunction with reduced-backlash version

Article No. supplement		1 or 9																						
Shaft design	→ Page 9/39																							
Adapter size		K4	B	C	D	E	F	G	H	J	K	L	M	N										4
		K2			D	E	F	G	H	J	K	L	M	N	P	Q								2
		KQ	A	B	C		D	E																7
		K8					A	B		C		D		E	F									8
		K5	A		B	C		D	E		F	G	H											5
		K3	A		B	C		D	E		F	G	H											3
Adapter type																								
Gearbox mounting type	→ Page 9/34		A, B, F or H																					

SIMOGEAR Gearboxes

Parallel shaft gearbox

Transmission ratios and torques

Selection and ordering data

Gearbox							Adapter											Article No.					
<i>i</i>	<i>n</i> ₂	<i>T</i> _{2N}	<i>F</i> _{R2}	ϕ ¹⁾	<i>J</i> _G	<i>R</i> _{ex}	K4	63	71	80	90	100	112	132	160	180	200	225	250			(Article No. supplement → below)	
-	rpm	Nm	N	'	10 ⁻⁴	-	K2			80	90	100	112	132	160	180	200	225	250	280	315		
							KQ	703	704	706			708	710									
							K8						808	810		813		816		818	822		
							K5	56		140	180			210	250		280	320	360				
							K3	56		140	180			210	250		280	320	360				

FZ.149

48.48	30	8 000	42 700	-	31	1600/33							✓	✓	✓	✓							2KJ3310 - ■ ■ A 0 ■ - 0 ■ T1
43.89	33	8 000	40 900	-	36	395/9							✓	✓	✓	✓							2KJ3310 - ■ ■ A 0 ■ - 0 ■ S1
38.55	38	8 000	38 600	-	44	2660/69							✓	✓	✓	✓							2KJ3310 - ■ ■ A 0 ■ - 0 ■ R1
34.93	42	8 000	36 900	-	51	524/15							✓	✓	✓	✓	✓						2KJ3310 - ■ ■ A 0 ■ - 0 ■ Q1
31.11	47	8 000	34 900	-	60	280/9							✓	✓	✓	✓	✓	✓					2KJ3310 - ■ ■ A 0 ■ - 0 ■ P1
27.94	52	8 000	33 200	-	72	1760/63							✓	✓	✓	✓	✓	✓					2KJ3310 - ■ ■ A 0 ■ - 0 ■ N1
24.93	58	8 000	31 400	-	84	1720/69							✓	✓	✓	✓	✓	✓					2KJ3310 - ■ ■ A 0 ■ - 0 ■ M1
22.22	65	8 000	29 600	-	98	200/9							✓	✓	✓	✓	✓	✓	✓	✓	✓		2KJ3310 - ■ ■ A 0 ■ - 0 ■ L1
19.71	74	8 000	27 900	-	117	1360/69							✓	✓	✓	✓	✓	✓	✓	✓	✓		2KJ3310 - ■ ■ A 0 ■ - 0 ■ K1
18.10	80	8 000	26 700	-	132	380/21							✓	✓	✓	✓	✓	✓	✓	✓	✓		2KJ3310 - ■ ■ A 0 ■ - 0 ■ J1
15.94	91	8 000	24 900	-	156	1100/69								✓	✓	✓	✓	✓	✓	✓	✓		2KJ3310 - ■ ■ A 0 ■ - 0 ■ H1
13.08	111	7 620	23 300	-	212	170/13								✓	✓	✓	✓	✓	✓	✓	✓		2KJ3310 - ■ ■ A 0 ■ - 0 ■ G1
11.47	126	7 320	23 700	-	241	172/15								✓	✓	✓	✓	✓	✓	✓	✓		2KJ3310 - ■ ■ A 0 ■ - 0 ■ F1
8.97	162	6 770	24 500	-	379	260/29								✓	✓	✓	✓	✓	✓	✓	✓		2KJ3310 - ■ ■ A 0 ■ - 0 ■ E1
8.09	179	5 690	23 900	-	200	2420/299								✓	✓	✓	✓	✓	✓	✓	✓		2KJ3310 - ■ ■ A 0 ■ - 0 ■ D1
6.64	218	5 690	24 000	-	277	1122/169								✓	✓	✓	✓	✓	✓	✓	✓		2KJ3310 - ■ ■ A 0 ■ - 0 ■ C1
5.82	249	5 680	24 000	-	325	1892/325								✓	✓	✓	✓	✓	✓	✓	✓		2KJ3310 - ■ ■ A 0 ■ - 0 ■ B1
4.55	319	5 650	23 600	-	517	132/29								✓	✓	✓	✓	✓	✓	✓	✓		2KJ3310 - ■ ■ A 0 ■ - 0 ■ A1

1) Only in conjunction with reduced-backlash version

Article No. supplement

Shaft design	→ Page 9/39	1 or 9																					
Adapter size		K4	B	C	D	E	F	G	H	J	K	L	M	N									4
		K2			D	E	F	G	H	J	K	L	M	N	P	Q							2
		KQ	A	B	C			D	E														7
		K8						A	B		C		D		E	F							8
		K5	A		B	C			D	E		F	G	H									5
		K3	A		B	C			D	E		F	G	H									3
Adapter type																							
Gearbox mounting type	→ Page 9/34																						A, B, F or H

Selection and ordering data

Gearbox							Adapter													Article No.				
<i>i</i>	<i>n</i> ₂	<i>T</i> _{2N}	<i>F</i> _{R2}	ϕ ¹⁾	<i>J</i> _G	<i>R</i> _{ex}	K4	63	71	80	90	100	112	132	160	180	200	225	250				(Article No. supplement → below)	
-	rpm	Nm	N	'	10 ⁻⁴	-	K2			80	90	100	112	132	160	180	200	225	250	280	315			
							KQ	703	704	706			708	710										
							K8						808	810		813		816		818	822			
							K5	56		140	180			210	250		280	320	360					
							K3	56		140	180			210	250		280	320	360					
FD.169																								
368.00	3.9	13 600	73 500	-	18	106240/289							✓	✓	✓									2KJ3411 - ■ ■ A 0 ■ - 0 ■ V1
343.01	4.2	13 600	73 500	-	19	52480/153							✓	✓	✓									2KJ3411 - ■ ■ A 0 ■ - 0 ■ U1
304.94	4.8	13 600	73 500	-	24	5184/17							✓	✓	✓									2KJ3411 - ■ ■ A 0 ■ - 0 ■ T1
273.80	5.3	13 600	73 500	-	28	51200/187							✓	✓	✓									2KJ3411 - ■ ■ A 0 ■ - 0 ■ S1
247.84	5.9	13 600	73 500	-	33	12640/51							✓	✓	✓									2KJ3411 - ■ ■ A 0 ■ - 0 ■ R1
217.70	6.7	13 600	73 500	-	40	85120/391							✓	✓	✓									2KJ3411 - ■ ■ A 0 ■ - 0 ■ Q1
197.27	7.4	13 600	73 500	-	46	16768/85							✓	✓	✓	✓								2KJ3411 - ■ ■ A 0 ■ - 0 ■ P1
175.69	8.3	13 600	73 500	-	54	8960/51							✓	✓	✓	✓	✓							2KJ3411 - ■ ■ A 0 ■ - 0 ■ N1
157.76	9.2	13 600	73 500	-	64	56320/357							✓	✓	✓	✓	✓	✓						2KJ3411 - ■ ■ A 0 ■ - 0 ■ M1
140.77	10	13 600	73 500	-	74	55040/391							✓	✓	✓	✓	✓	✓						2KJ3411 - ■ ■ A 0 ■ - 0 ■ L1
125.49	12	13 600	73 500	-	86	6400/51							✓	✓	✓	✓	✓	✓	✓					2KJ3411 - ■ ■ A 0 ■ - 0 ■ K1
111.30	13	13 600	73 500	-	101	2560/23							✓	✓	✓	✓	✓	✓	✓					2KJ3411 - ■ ■ A 0 ■ - 0 ■ J1
102.18	14	13 600	73 500	-	113	12160/119							✓	✓	✓	✓	✓	✓	✓					2KJ3411 - ■ ■ A 0 ■ - 0 ■ H1
90.03	16	13 600	73 500	-	132	35200/391								✓	✓	✓	✓	✓	✓					2KJ3411 - ■ ■ A 0 ■ - 0 ■ G1
73.85	20	13 600	71 300	-	176	960/13								✓	✓	✓	✓	✓	✓					2KJ3411 - ■ ■ A 0 ■ - 0 ■ F1
64.75	22	13 600	67 500	-	194	5504/85								✓	✓	✓	✓	✓	✓					2KJ3411 - ■ ■ A 0 ■ - 0 ■ E1
50.63	29	13 600	60 700	-	302	24960/493								✓	✓	✓	✓	✓	✓					2KJ3411 - ■ ■ A 0 ■ - 0 ■ D1
46.55	31	13 600	58 400	-	201	3026/65								✓	✓	✓	✓	✓	✓					2KJ3411 - ■ ■ A 0 ■ - 0 ■ C1
40.82	36	13 600	55 100	-	226	15308/375								✓	✓	✓	✓	✓	✓					2KJ3411 - ■ ■ A 0 ■ - 0 ■ B1
31.92	45	13 600	53 400	-	355	4628/145								✓	✓	✓	✓	✓	✓					2KJ3411 - ■ ■ A 0 ■ - 0 ■ A1

1) Only in conjunction with reduced-backlash version

Article No. supplement		1 or 9																						
Shaft design	→ Page 9/39																							
Adapter size		K4	B	C	D	E	F	G	H	J	K	L	M	N										4
		K2			D	E	F	G	H	J	K	L	M	N	P	Q								2
		KQ	A	B	C		D	E																7
		K8					A	B		C		D	E	F										8
		K5	A		B	C		D	E		F	G	H											5
		K3	A		B	C		D	E		F	G	H											3
Adapter type																								
Gearbox mounting type	→ Page 9/34	A, B, F or H																						

SIMOGEAR Gearboxes

Parallel shaft gearbox

Transmission ratios and torques

Selection and ordering data

Gearbox							Adapter													Article No.												
<i>i</i>	<i>n</i> ₂	<i>T</i> _{2N}	<i>F</i> _{R2}	ϕ ¹⁾	<i>J</i> _G	<i>R</i> _{ex}	K4	63	71	80	90	100	112	132	160	180	200	225	250												(Article No. supplement → below)	
-	rpm	Nm	N	'	10 ⁻⁴	-	K2				80	90	100	112	132	160	180	200	225	250	280	315										
							KQ	703	704	706			708	710																		
							K8						808	810		813			816			818	822									
							K5	56		140	180			210	250			280	320	360												
							K3	56		140	180			210	250			280	320	360												
FZ.169																																
44.93	32	12 400	60 000	-	68	3100/69							✓	✓	✓															2KJ3311 - ■ ■ A 0 ■ - 0 ■ S1		
41.07	35	13 600	55 200	-	80	616/15							✓	✓	✓	✓														2KJ3311 - ■ ■ A 0 ■ - 0 ■ R1		
36.94	39	13 600	52 600	-	95	665/18							✓	✓	✓	✓	✓													2KJ3311 - ■ ■ A 0 ■ - 0 ■ Q1		
33.02	44	13 600	49 900	-	111	2080/63							✓	✓	✓	✓	✓	✓												2KJ3311 - ■ ■ A 0 ■ - 0 ■ P1		
29.86	49	13 600	47 600	-	133	2060/69							✓	✓	✓	✓	✓	✓												2KJ3311 - ■ ■ A 0 ■ - 0 ■ N1		
26.35	55	13 600	44 800	-	157	1660/63							✓	✓	✓	✓	✓	✓	✓	✓										2KJ3311 - ■ ■ A 0 ■ - 0 ■ M1		
23.48	62	13 600	42 300	-	186	540/23							✓	✓	✓	✓	✓	✓	✓	✓	✓									2KJ3311 - ■ ■ A 0 ■ - 0 ■ L1		
21.27	68	13 600	42 300	-	206	1340/63							✓	✓	✓	✓	✓	✓	✓	✓	✓									2KJ3311 - ■ ■ A 0 ■ - 0 ■ K1		
19.13	76	13 600	42 800	-	249	440/23								✓	✓	✓	✓	✓	✓	✓	✓									2KJ3311 - ■ ■ A 0 ■ - 0 ■ J1		
15.90	91	13 500	43 200	-	314	620/39								✓	✓	✓	✓	✓	✓	✓	✓									2KJ3311 - ■ ■ A 0 ■ - 0 ■ H1		
14.13	103	12 900	43 200	-	386	212/15								✓	✓	✓	✓	✓	✓	✓	✓									2KJ3311 - ■ ■ A 0 ■ - 0 ■ G1		
11.26	129	11 700	42 800	-	534	980/87								✓	✓	✓	✓	✓	✓	✓	✓									2KJ3311 - ■ ■ A 0 ■ - 0 ■ F1		
8.97	162	10 400	41 900	-	710	260/29										✓	✓	✓	✓	✓	✓									2KJ3311 - ■ ■ A 0 ■ - 0 ■ E1		
8.07	180	8 350	39 300	-	396	1364/169								✓	✓	✓	✓	✓	✓	✓	✓									2KJ3311 - ■ ■ A 0 ■ - 0 ■ D1		
7.18	202	8 310	38 900	-	489	2332/325								✓	✓	✓	✓	✓	✓	✓	✓									2KJ3311 - ■ ■ A 0 ■ - 0 ■ C1		
5.72	253	8 210	37 800	-	697	2156/377								✓	✓	✓	✓	✓	✓	✓	✓									2KJ3311 - ■ ■ A 0 ■ - 0 ■ B1		
4.55	319	7 300	36 500	-	967	132/29										✓	✓	✓	✓	✓	✓									2KJ3311 - ■ ■ A 0 ■ - 0 ■ A1		

1) Only in conjunction with reduced-backlash version

Article No. supplement																																
Shaft design					→ Page 9/39										1 or 9																	
Adapter size					K4	B	C	D	E	F	G	H	J	K	L	M	N															4
					K2			D	E	F	G	H	J	K	L	M	N	P	Q													2
					KQ		A	B	C		D	E																				7
					K8						A	B		C		D		E	F													8
					K5		A		B	C		D	E		F	G	H															5
					K3		A		B	C		D	E		F	G	H															3
Adapter type																																
Gearbox mounting type					→ Page 9/34										A, B, F or H																	

Selection and ordering data

Gearbox							Adapter													Article No.						
<i>i</i>	<i>n</i> ₂	<i>T</i> _{2N}	<i>F</i> _{R2}	ϕ ¹⁾	<i>J</i> _G	<i>R</i> _{ex}	K4	63	71	80	90	100	112	132	160	180	200	225	250					(Article No. supplement → below)		
-	rpm	Nm	N	'	10 ⁻⁴	-	K2			80	90	100	112	132	160	180	200	225	250	280	315					
							KQ	703	704	706			708	710												
							K8						808	810		813		816		818	822					
							K5	56		140	180			210	250		280	320	360							
							K3	56		140	180			210	250		280	320	360							
FD.189																										
347.35	4.2	19 000	110 900	-	36	590499/1700							✓	✓	✓										2KJ3412 - ■ ■ A 0 ■ - 0 ■ T1	
310.76	4.7	19 000	110 900	-	43	290563/935							✓	✓	✓										2KJ3412 - ■ ■ A 0 ■ - 0 ■ S1	
280.27	5.2	19 000	110 900	-	49	571753/2040							✓	✓	✓										2KJ3412 - ■ ■ A 0 ■ - 0 ■ R1	
247.71	5.9	19 000	110 900	-	61	290563/1173							✓	✓	✓										2KJ3412 - ■ ■ A 0 ■ - 0 ■ Q1	
226.42	6.4	19 000	110 900	-	71	1443442/6375							✓	✓	✓	✓									2KJ3412 - ■ ■ A 0 ■ - 0 ■ P1	
203.69	7.1	19 000	110 900	-	84	1246609/6120							✓	✓	✓	✓	✓								2KJ3412 - ■ ■ A 0 ■ - 0 ■ N1	
182.03	8	19 000	110 900	-	98	139256/765							✓	✓	✓	✓	✓	✓							2KJ3412 - ■ ■ A 0 ■ - 0 ■ M1	
164.61	8.8	19 000	110 900	-	117	965419/5865							✓	✓	✓	✓	✓	✓							2KJ3412 - ■ ■ A 0 ■ - 0 ■ L1	
145.28	10	19 000	110 900	-	136	111137/765							✓	✓	✓	✓	✓	✓	✓						2KJ3412 - ■ ■ A 0 ■ - 0 ■ K1	
129.45	11	19 000	110 900	-	160	253071/1955							✓	✓	✓	✓	✓	✓	✓						2KJ3412 - ■ ■ A 0 ■ - 0 ■ J1	
117.27	12	19 000	110 900	-	177	89713/765							✓	✓	✓	✓	✓	✓	✓						2KJ3412 - ■ ■ A 0 ■ - 0 ■ H1	
105.48	14	19 000	110 900	-	214	206206/1955								✓	✓	✓	✓	✓	✓						2KJ3412 - ■ ■ A 0 ■ - 0 ■ G1	
87.65	17	19 000	108 400	-	263	22351/255								✓	✓	✓	✓	✓	✓						2KJ3412 - ■ ■ A 0 ■ - 0 ■ F1	
77.92	19	19 000	103 300	-	323	496769/6375								✓	✓	✓	✓	✓	✓						2KJ3412 - ■ ■ A 0 ■ - 0 ■ E1	
62.11	23	19 000	94 100	-	437	459277/7395							✓	✓	✓	✓	✓	✓	✓						2KJ3412 - ■ ■ A 0 ■ - 0 ■ D1	
49.43	29	19 000	85 500	-	557	121849/2465										✓	✓	✓	✓						2KJ3412 - ■ ■ A 0 ■ - 0 ■ C1	
40.61	36	19 000	78 500	-	478	35329/870							✓	✓	✓	✓	✓	✓	✓						2KJ3412 - ■ ■ A 0 ■ - 0 ■ B1	
32.32	45	19 000	70 900	-	621	9373/290										✓	✓	✓	✓						2KJ3412 - ■ ■ A 0 ■ - 0 ■ A1	

1) Only in conjunction with reduced-backlash version

Article No. supplement		1 or 9																						
Shaft design	→ Page 9/39																							
Adapter size		K4	B	C	D	E	F	G	H	J	K	L	M	N										4
		K2			D	E	F	G	H	J	K	L	M	N	P	Q								2
		KQ	A	B	C		D	E																7
		K8					A	B		C		D		E	F									8
		K5	A		B	C		D	E		F	G	H											5
		K3	A		B	C		D	E		F	G	H											3
Adapter type																								
Gearbox mounting type	→ Page 9/34	A, B, F or H																						



SIMOGEAR Gearboxes

Parallel shaft gearbox

Transmission ratios and torques

Selection and ordering data

Gearbox							Adapter													Article No.						
<i>i</i>	<i>n</i> ₂	<i>T</i> _{2N}	<i>F</i> _{R2}	ϕ ¹⁾	<i>J</i> _G	<i>R</i> _{ex}	K4	63	71	80	90	100	112	132	160	180	200	225	250					(Article No. supplement → below)		
-	rpm	Nm	N	'	10 ⁻⁴	-	K2			80	90	100	112	132	160	180	200	225	250	280	315					
							KQ	703	704	706			708	710												
							K8						808	810		813		816		818	822					
							K5	56		140	180		210	250		280	320	360								
							K3	56		140	180		210	250		280	320	360								
FZ.189																										
37.93	38	19 000	76 200	- 143	11948/315								✓	✓	✓	✓	✓	✓							2KJ3312 - ■ ■ A 0 ■ - 0 ■ L1	
34.03	43	19 000	72 600	- 169	3914/115								✓	✓	✓	✓	✓	✓							2KJ3312 - ■ ■ A 0 ■ - 0 ■ K1	
30.41	48	19 000	69 000	- 202	3193/105								✓	✓	✓	✓	✓	✓	✓	✓					2KJ3312 - ■ ■ A 0 ■ - 0 ■ J1	
27.17	53	19 000	65 500	- 241	9373/345								✓	✓	✓	✓	✓	✓	✓	✓					2KJ3312 - ■ ■ A 0 ■ - 0 ■ H1	
24.85	58	19 000	62 800	- 269	7828/315								✓	✓	✓	✓	✓	✓	✓	✓	✓				2KJ3312 - ■ ■ A 0 ■ - 0 ■ G1	
22.09	66	19 000	59 400	- 319	7622/345								✓	✓	✓	✓	✓	✓	✓	✓	✓				2KJ3312 - ■ ■ A 0 ■ - 0 ■ F1	
18.75	77	19 000	54 800	- 406	7313/390								✓	✓	✓	✓	✓	✓	✓	✓	✓				2KJ3312 - ■ ■ A 0 ■ - 0 ■ E1	
16.21	89	19 000	50 900	- 489	6077/375								✓	✓	✓	✓	✓	✓	✓	✓	✓				2KJ3312 - ■ ■ A 0 ■ - 0 ■ D1	
13.26	109	17 600	48 700	- 677	5768/435								✓	✓	✓	✓	✓	✓	✓	✓	✓				2KJ3312 - ■ ■ A 0 ■ - 0 ■ C1	
10.89	133	16 300	50 000	- 906	4738/435										✓	✓	✓	✓	✓	✓	✓				2KJ3312 - ■ ■ A 0 ■ - 0 ■ B1	
8.47	171	14 700	50 400	- 1 333	3811/450															✓	✓	✓			2KJ3312 - ■ ■ A 0 ■ - 0 ■ A1	

¹⁾ Only in conjunction with reduced-backlash version

Article No. supplement

Shaft design	→ Page 9/39	1 or 9																									
Adapter size		K4	B	C	D	E	F	G	H	J	K	L	M	N												4	
		K2			D	E	F	G	H	J	K	L	M	N	P	Q										2	
		KQ	A	B	C		D	E																		7	
		K8					A	B		C		D		E	F											8	
		K5	A		B	C		D	E		F	G	H													5	
		K3	A		B	C		D	E		F	G	H													3	
Adapter type																											
Gearbox mounting type	→ Page 9/34	A, B, F or H																									

Dimensional drawing overview

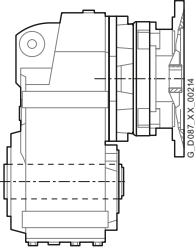
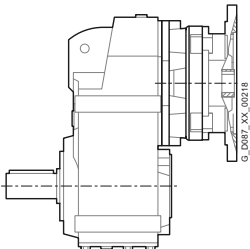
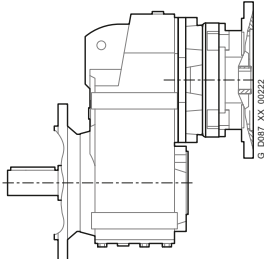
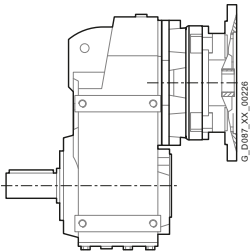
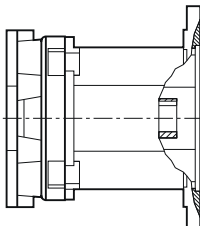
Design	Gearbox type	Dimensional drawing on page
Parallel shaft gearbox with adapter K4		
<i>Shaft-mounted design</i>		
	FDAD./FZAD.29	4/28
	FDAD./FZAD.39	4/32
	FDAD./FZAD.49	4/36
	FDAD./FZAD.69	4/40
	FDAD./FZAD.79	4/44
	FDAD./FZAD.89	4/48
	FDAD./FZAD.109	4/52
	FDAD./FZAD.129	4/56
	FDAD./FZAD.149	4/60
	FDAD./FZAD.169	4/64
	FDAD./FZAD.189	4/68
<i>Housing flange design</i>		
	FD.Z./FZ.Z.29	4/29
	FD.Z./FZ.Z.39	4/33
	FD.Z./FZ.Z.49	4/37
	FD.Z./FZ.Z.69	4/41
	FD.Z./FZ.Z.79	4/45
	FD.Z./FZ.Z.89	4/49
	FD.Z./FZ.Z.109	4/53
	FD.Z./FZ.Z.129	4/57
	FD.Z./FZ.Z.149	4/61
	FD.Z./FZ.Z.169	4/65
	FD.Z./FZ.Z.189	4/69
<i>Flange-mounted design</i>		
	FD.F./FZ.F.29	4/30
	FD.F./FZ.F.39	4/34
	FD.F./FZ.F.49	4/38
	FD.F./FZ.F.69	4/42
	FD.F./FZ.F.79	4/46
	FD.F./FZ.F.89	4/50
	FD.F./FZ.F.109	4/54
	FD.F./FZ.F.129	4/58
	FD.F./FZ.F.149	4/62
	FD.F./FZ.F.169	4/66
	FD.F./FZ.F.189	4/70
<i>Foot-mounted design</i>		
	FD../FZ..29	4/31
	FD../FZ..39	4/35
	FD../FZ..49	4/39
	FD../FZ..69	4/43
	FD../FZ..79	4/47
	FD../FZ..89	4/51
	FD../FZ..109	4/55
	FD../FZ..129	4/59
	FD../FZ..149	4/63
	FD../FZ..169	4/67
	FD../FZ..189	4/71
Parallel shaft gearbox with adapter K2		
	FD../FZ..29 ... FD../FZ..189	4/72

SIMOGEAR Gearboxes



Parallel shaft gearboxes

Dimensions

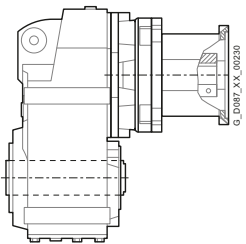
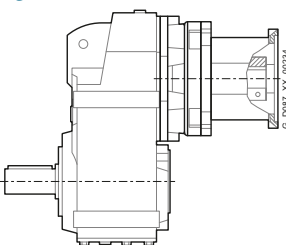
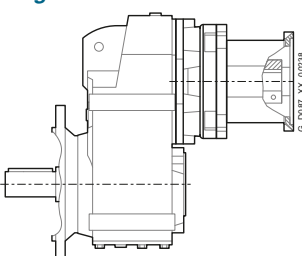
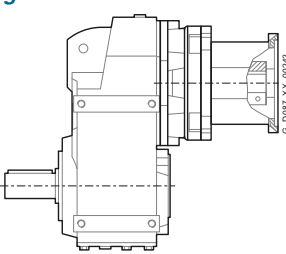
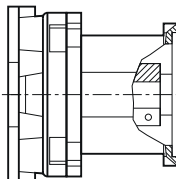
Dimensional drawing overview (continued)

Design	Gearbox type	Dimensional drawing on page
Parallel shaft gearbox with adapter KQ		
<i>Shaft-mounted design</i>		
	FDAD./FZAD.29	4/75
	FDAD./FZAD.39	4/79
	FDAD./FZAD.49	4/83
	FDAD./FZAD.69	4/87
	FDAD./FZAD.79	4/91
	FDAD./FZAD.89	4/95
	FDAD./FZAD.109	4/99
	FDAD./FZAD.129	4/103
	FDAD./FZAD.149	4/107
	FDAD./FZAD.169	4/111
FDAD./FZAD.189	4/115	
<i>Housing flange design</i>		
	FD.Z./FZ.Z.29	4/76
	FD.Z./FZ.Z.39	4/80
	FD.Z./FZ.Z.49	4/84
	FD.Z./FZ.Z.69	4/88
	FD.Z./FZ.Z.79	4/92
	FD.Z./FZ.Z.89	4/96
	FD.Z./FZ.Z.109	4/100
	FD.Z./FZ.Z.129	4/104
	FD.Z./FZ.Z.149	4/108
	FD.Z./FZ.Z.169	4/112
FD.Z./FZ.Z.189	4/116	
<i>Flange-mounted design</i>		
	FD.F./FZ.F.29	4/77
	FD.F./FZ.F.39	4/81
	FD.F./FZ.F.49	4/85
	FD.F./FZ.F.69	4/89
	FD.F./FZ.F.79	4/93
	FD.F./FZ.F.89	4/97
	FD.F./FZ.F.109	4/101
	FD.F./FZ.F.129	4/105
	FD.F./FZ.F.149	4/109
	FD.F./FZ.F.169	4/113
FD.F./FZ.F.189	4/117	
<i>Foot-mounted design</i>		
	FD../FZ..29	4/78
	FD../FZ..39	4/82
	FD../FZ..49	4/86
	FD../FZ..69	4/90
	FD../FZ..79	4/94
	FD../FZ..89	4/98
	FD../FZ..109	4/102
	FD../FZ..129	4/106
	FD../FZ..149	4/110
	FD../FZ..169	4/114
FD../FZ..189	4/118	
Parallel shaft gearbox with adapter KQS		
	FD../FZ..29 ... FD../FZ..189	4/119

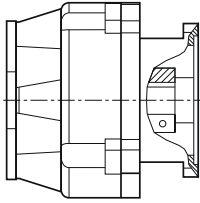
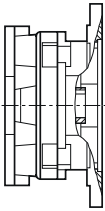
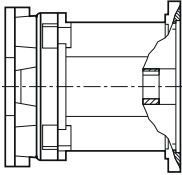
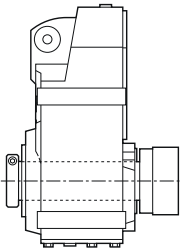
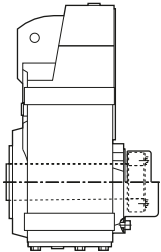
Dimensional drawing overview (continued)

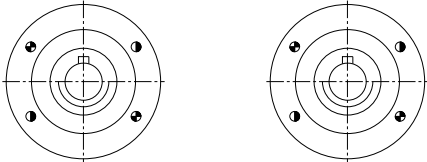
Design	Gearbox type	Dimensional drawing on page
	FD../FZ..29 ... FD../FZ..189	4/121
Parallel shaft gearbox with adapter K5 	FD../FZ..29 ... FD../FZ..189	4/122
Parallel shaft gearbox with adapter K3 	FD../FZ..29 ... FD../FZ..189	4/124
Additional versions and options 	SIMOLOC assembly system	4/126
	Protection cover for hollow shaft	4/128
	Inner contour flange-mounted design	4/129
	Pin holes	4/131

SIMOGEAR Gearboxes

Parallel shaft gearbox with adapter K4

Dimensions

FDAD/FZAD.29 gearbox in a shaft-mounted design

FAD030K4, FADS030K4

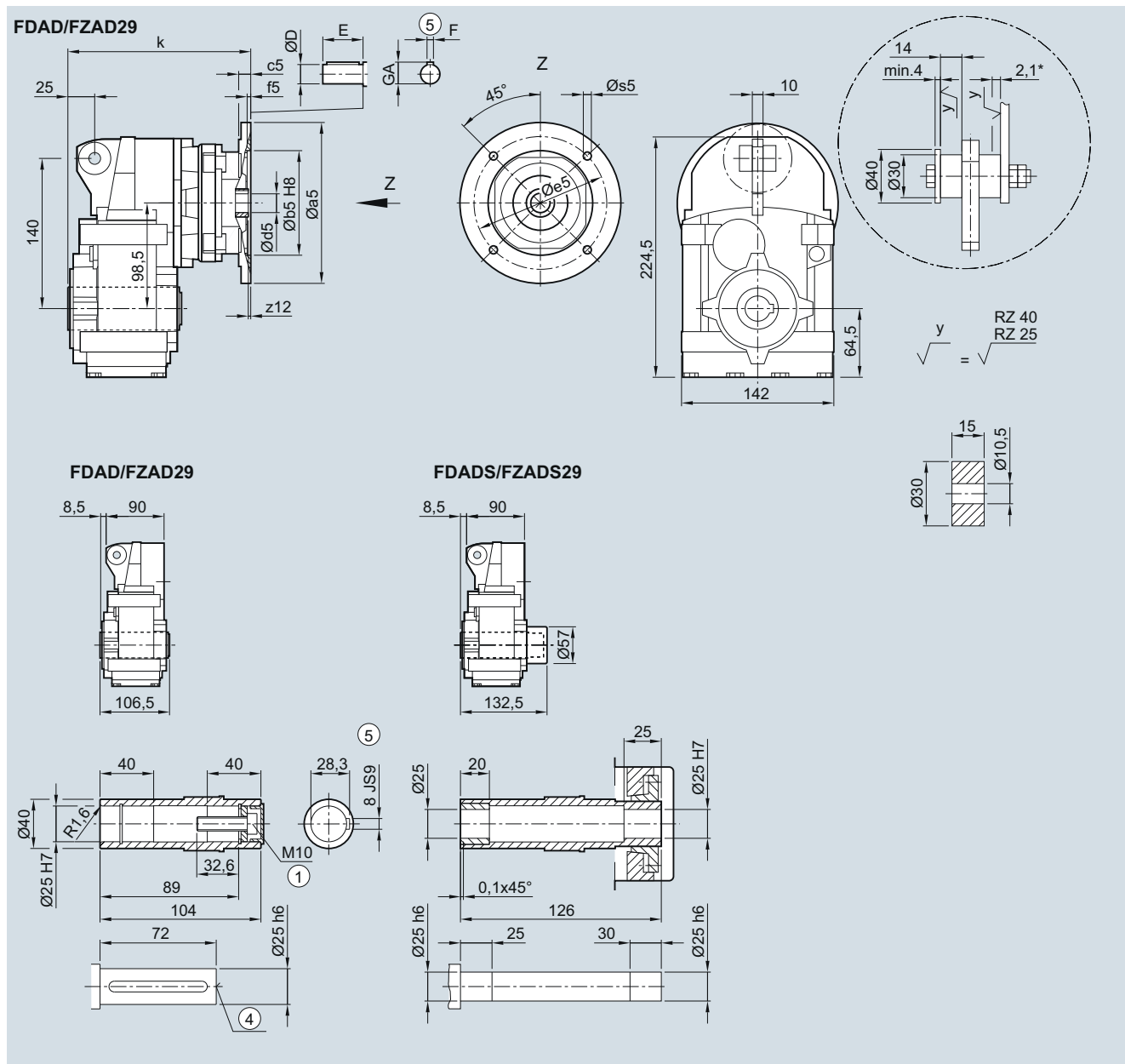

Adapter	a5	b5	c5	f5	e5	s5	z12	d5/D	E	F	GA	k
63	140	95	12	4.5	115	M8	2.5	11	23	4	12.5	177.0
71	160	110	12	4.5	130	M8	2.5	14	30	5	16.0	177.0
80	200	130	15	4.5	165	M10	4.0	19	40	6	12.5	205.0
90	200	130	15	4.5	165	M10	4.0	24	50	8	27.0	205.0
100	250	180	14	5.0	215	M12x21	7.5	28	60	8	31.0	259.5

① ISO 4017

④ DIN 332

⑤ Feather key/keyway DIN 6885

* Spring compression at max. torque

FD.Z./FZ.Z.29 gearbox in a housing flange design

FZ030K4, FAZ030K4, FAZS030K4

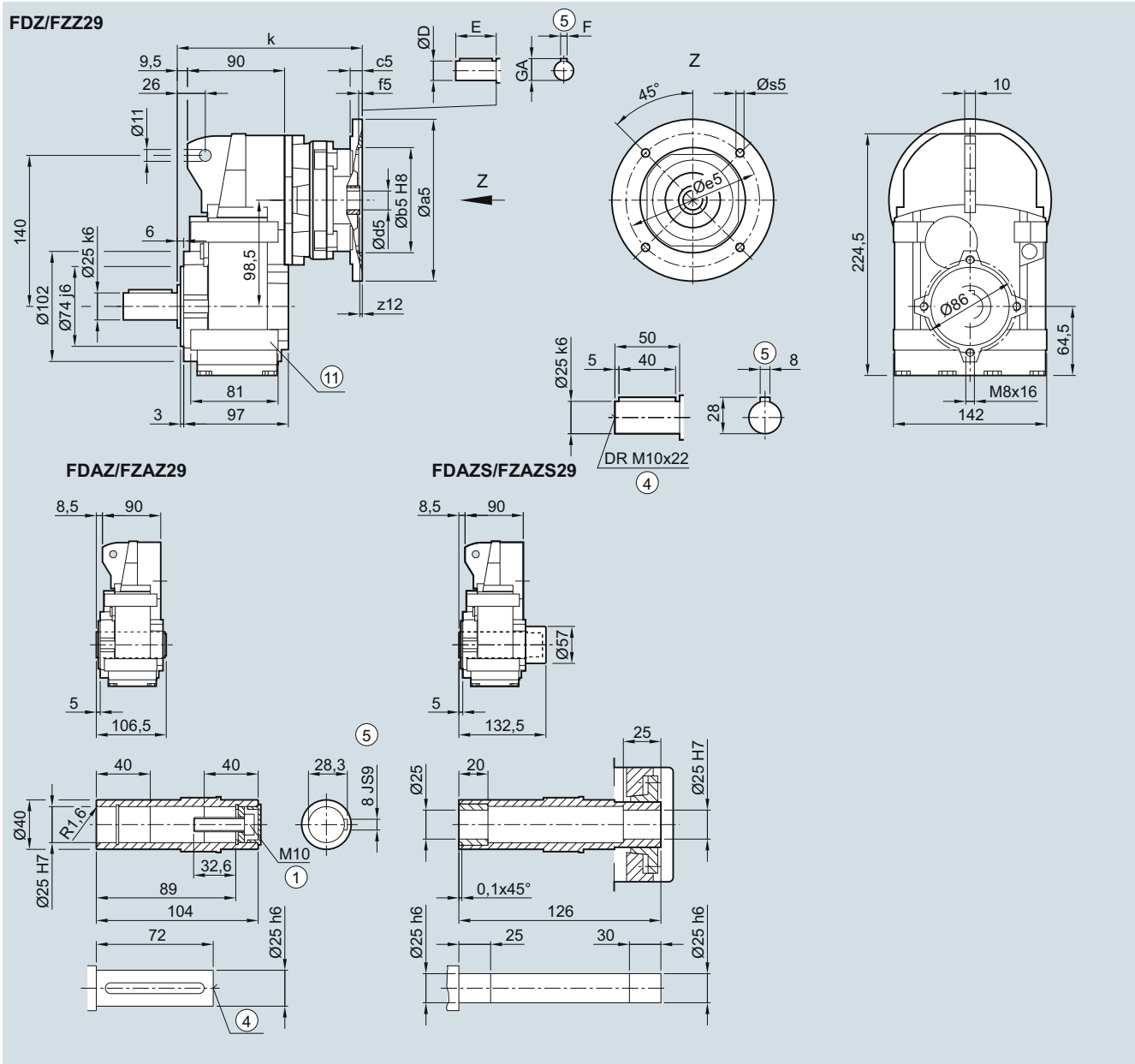

4

Adapter	a5	b5	c5	f5	e5	s5	z12	d5/D	E	F	GA	k
63	140	95	12	4.5	115	M8	2.5	11	23	4	12.5	177.0
71	160	110	12	4.5	130	M8	2.5	14	30	5	16.0	177.0
80	200	130	15	4.5	165	M10	4.0	19	40	6	12.5	205.0
90	200	130	15	4.5	165	M10	4.0	24	50	8	27.0	205.0
100	250	180	14	5.0	215	M12x21	7.5	28	60	8	31.0	259.5

① ISO 4017

④ DIN 332

⑤ Feather key/keyway DIN 6885

⑩ Use bores only for foot-mounted design

SIMOGEAR Gearboxes

Parallel shaft gearbox with adapter K4

Dimensions

FD.F./FZ.F.29 gearbox in a flange-mounted design

FF030K4, FAF030K4, FAFS030K4

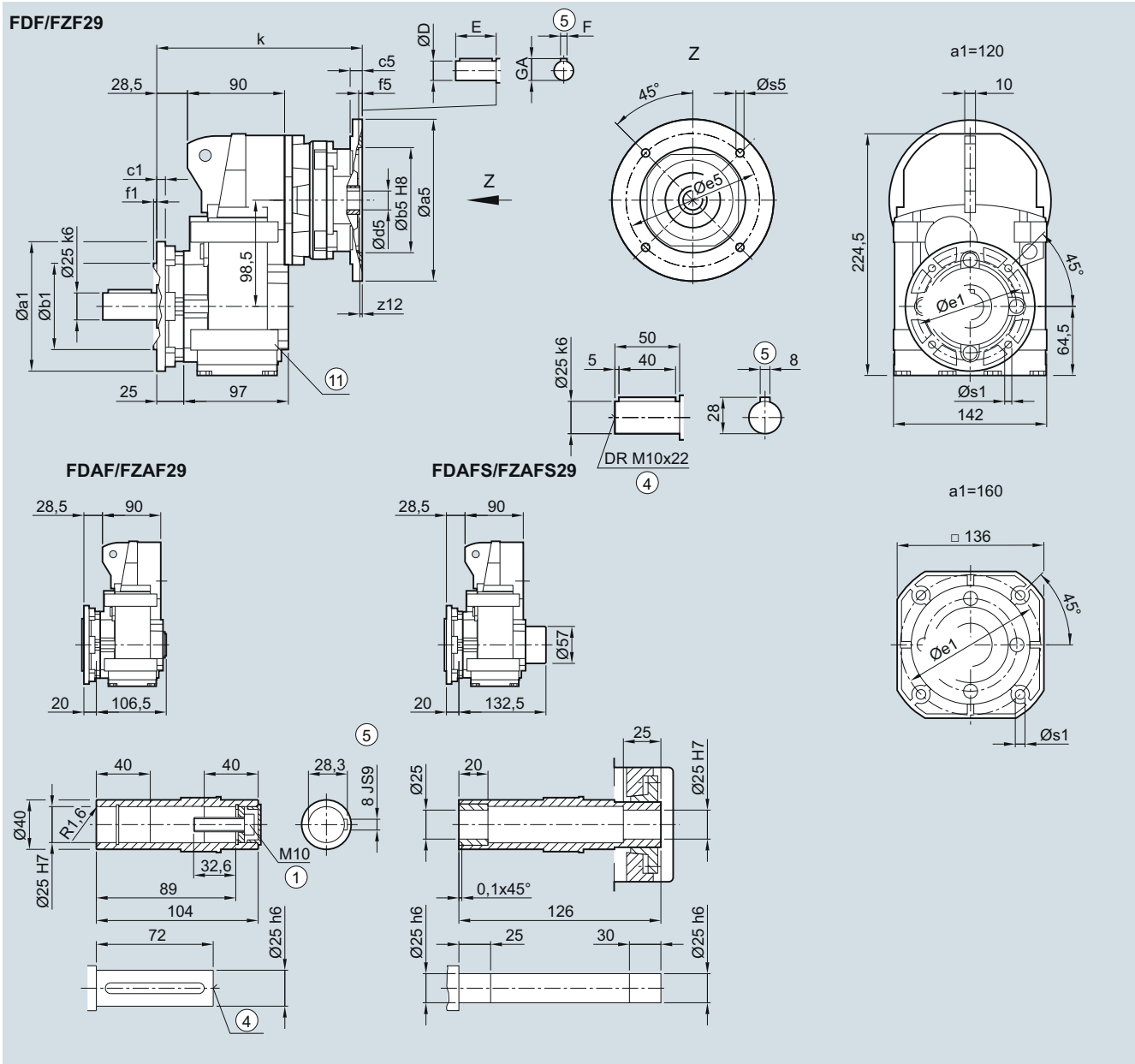

Flange	a1	b1	to2	c1	e1	f1	s1					
	120	80	j6	8	100	3.0	6.6					
	160	110	j6	9	130	3.5	9.0					
Adapter	a5	b5	c5	f5	e5	s5	z12	d5/D	E	F	GA	k
63	140	95	12	4.5	115	M8	2.5	11	23	4	12.5	196.0
71	160	110	12	4.5	130	M8	2.5	14	30	5	16.0	196.0
80	200	130	15	4.5	165	M10	4.0	19	40	6	12.5	224.0
90	200	130	15	4.5	165	M10	4.0	24	50	8	27.0	224.0
100	250	180	14	5.0	215	M12x21	7.5	28	60	8	31.0	278.5

① ISO 4017

④ DIN 332

⑤ Feather key/keyway DIN 6885

⑩ For inner contour, see page 4/129

⑪ Use bores only for foot-mounted design

FD../FZ..29 gearbox in a foot-mounted design

F030K4, FA030K4, FAS030K4

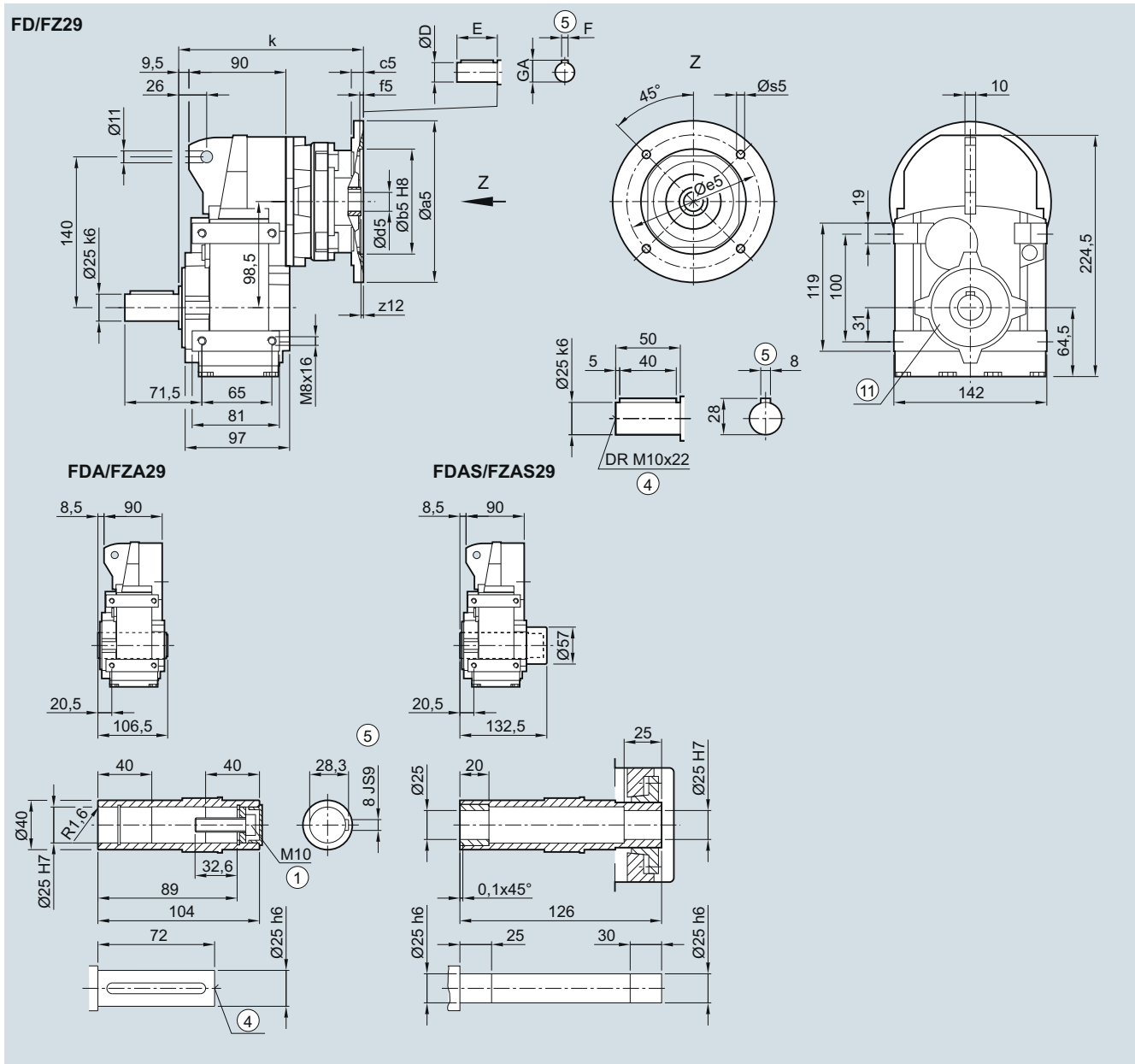

Adapter	a5	b5	c5	f5	e5	s5	z12	d5/D	E	F	GA	k
63	140	95	12	4.5	115	M8	2.5	11	23	4	12.5	177.0
71	160	110	12	4.5	130	M8	2.5	14	30	5	16.0	177.0
80	200	130	15	4.5	165	M10	4.0	19	40	6	12.5	205.0
90	200	130	15	4.5	165	M10	4.0	24	50	8	27.0	205.0
100	250	180	14	5.0	215	M12x21	7.5	28	60	8	31.0	259.5

① ISO 4017

④ DIN 332

⑤ Feather key/keyway DIN 6885

⑩ Use bores only for housing flange design

SIMOGEAR Gearboxes

Parallel shaft gearbox with adapter K4

Dimensions

FDAD/FZAD.39 gearbox in a shaft-mounted design

FAD030K4, FADS030K4, FADT030K4

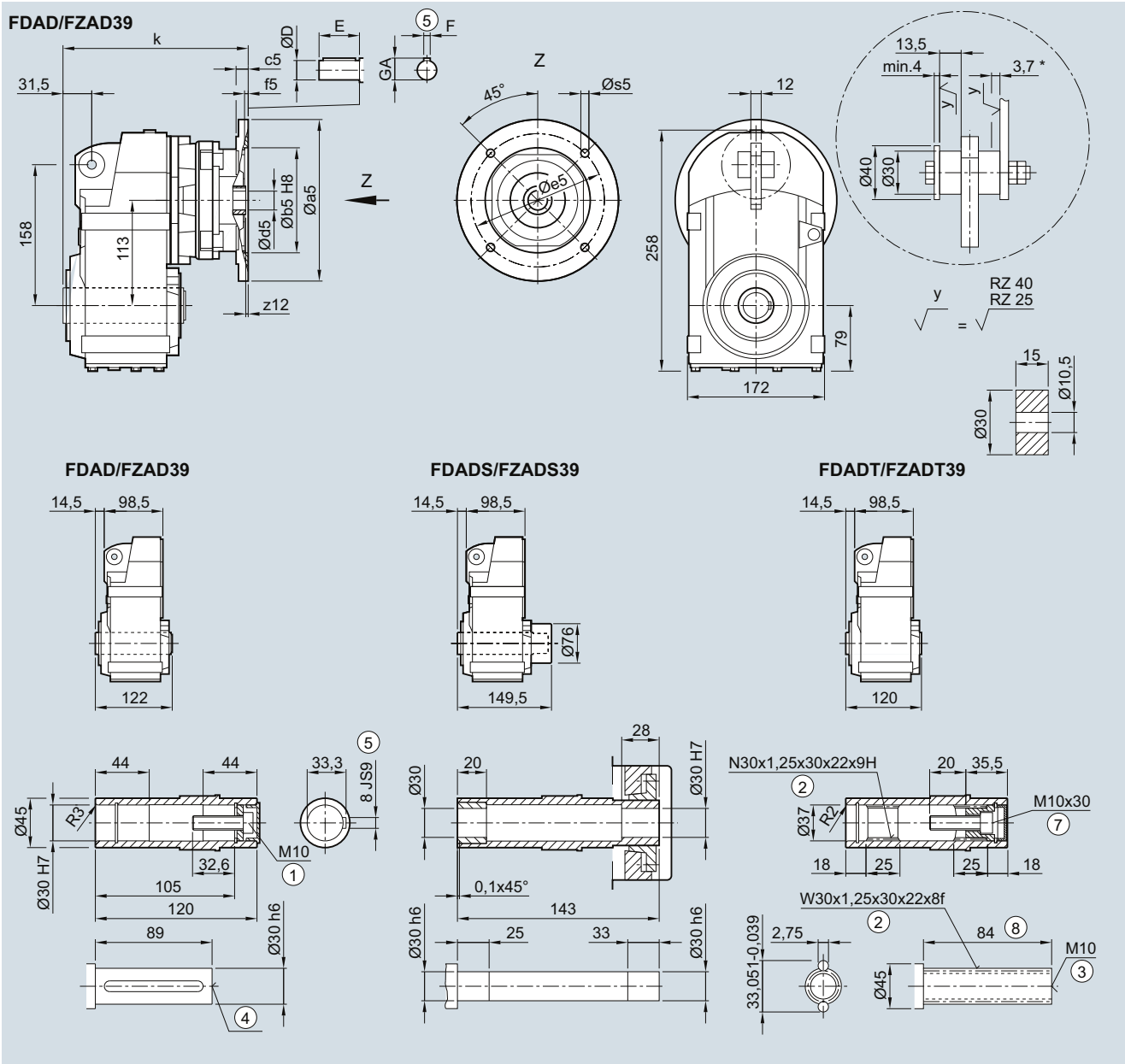

Adapter	a5	b5	c5	f5	e5	s5	z12	d5/D	E	F	GA	k
63	140	95	12	4.5	115	M8	2.5	11	23	4	12.5	190.5
71	160	110	12	4.5	130	M8	2.5	14	30	5	16.0	190.5
80	200	130	15	4.5	165	M10	4.0	19	40	6	12.5	218.5
90	200	130	15	4.5	165	M10	4.0	24	50	8	27.0	218.5
100	250	180	14	5.0	215	M12x21	7.5	28	60	8	31.0	273.0
112	250	180	14	5.0	215	M12x21	7.5	28	60	8	31.0	273.0

① ISO 4014 ② DIN 5480 ③ DIN 332-D ④ DIN 332 ⑤ Feather key/keyway DIN 6885 ⑦ ISO 4762 ⑥ Without locating shoulder +1 mm

* Spring compression at max. torque

FD.Z./FZ.Z.39 gearbox in a housing flange design

FZ030K4, FAZ030K4, FAZS030K4, FAZT030K4

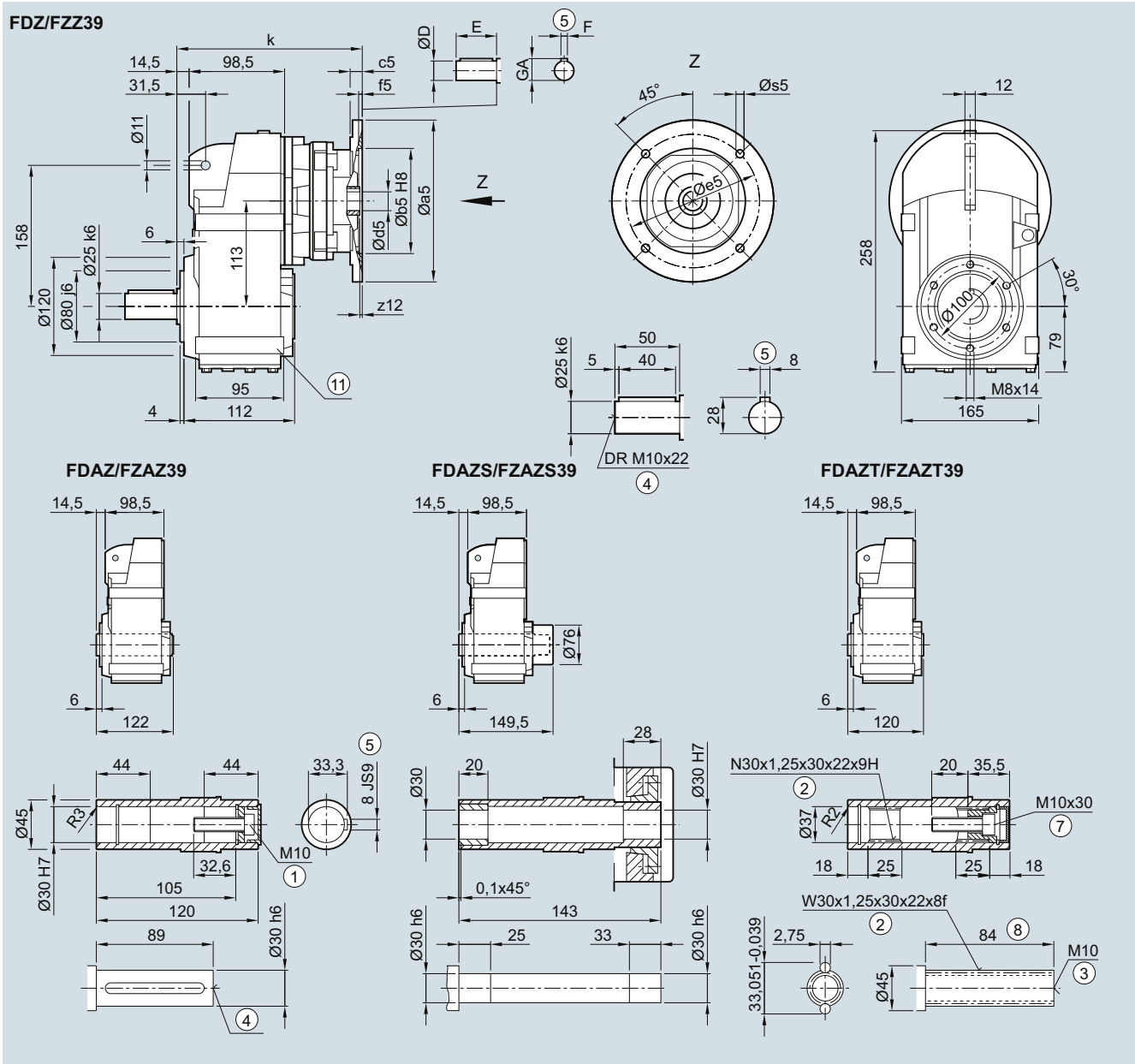

Adapter	a5	b5	c5	f5	e5	s5	z12	d5/D	E	F	GA	k
63	140	95	12	4.5	115	M8	2.5	11	23	4	12.5	190.5
71	160	110	12	4.5	130	M8	2.5	14	30	5	16.0	190.5
80	200	130	15	4.5	165	M10	4.0	19	40	6	12.5	218.5
90	200	130	15	4.5	165	M10	4.0	24	50	8	27.0	218.5
100	250	180	14	5.0	215	M12x21	7.5	28	60	8	31.0	273.0
112	250	180	14	5.0	215	M12x21	7.5	28	60	8	31.0	273.0

① ISO 4014 ② DIN 5480 ③ DIN 332-D ④ DIN 332
 ⑤ Feather key/keyway DIN 6885 ⑦ ISO 4762 ⑧ Without locating shoulder +1 mm ⑩ Use bores only for foot-mounted design



SIMOGEAR Gearboxes

Parallel shaft gearbox with adapter K4

Dimensions

FD.F./FZ.F.39 in a flange-mounted design

FF030K4, FAF030K4, FAFS030K4, FAFT030K4

4

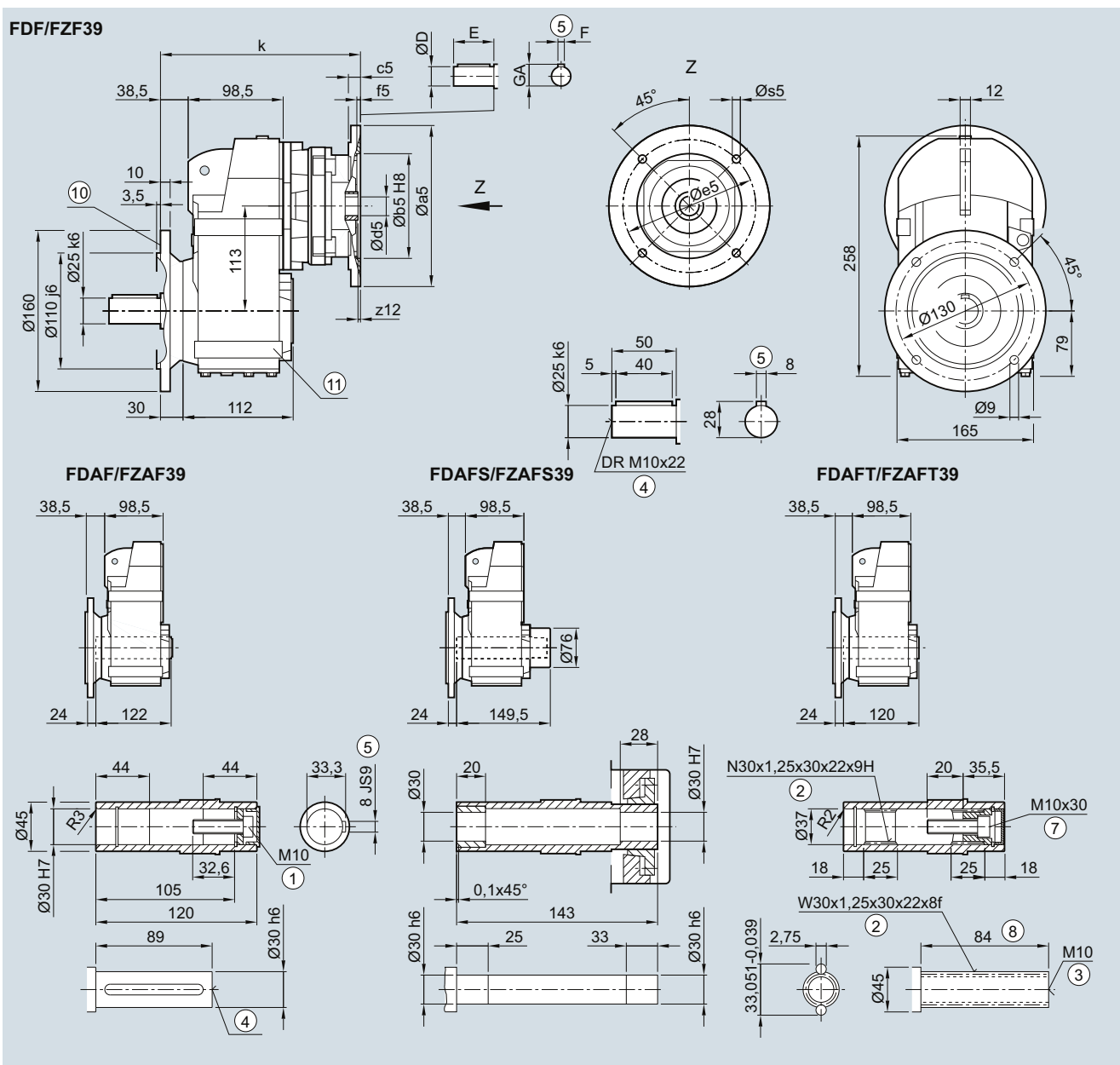

Adapter	a5	b5	c5	f5	e5	s5	z12	d5/D	E	F	GA	k
63	140	95	12	4.5	115	M8	2.5	11.0	23	4	12.5	214.5
71	160	110	12	4.5	130	M8	2.5	14.0	30	5	16.0	214.5
80	200	130	15	4.5	165	M10	4.0	19.0	40	6	12.5	242.5
90	200	130	15	4.5	165	M10	4.0	24.0	50	8	27.0	242.5
100	250	180	14	5.0	215	M12x21	7.5	28.0	60	8	31.0	297.0
112	250	180	14	5.0	215	M12x21	7.5	28.0	60	8	31.0	297.0

- ① ISO 4014 ② DIN 5480 ③ DIN 332-D ④ DIN 332 ⑤ Feather key/keyway DIN 6885
 ⑦ ISO 4762 ⑧ Without locating shoulder +1 mm ⑨ For inner contour, see page 4/129 ⑩ Use bores only for foot-mounted design

FD./FZ..39 gearbox in a foot-mounted design

F030K4, FA030K4, FAS030K4, FAT030K4

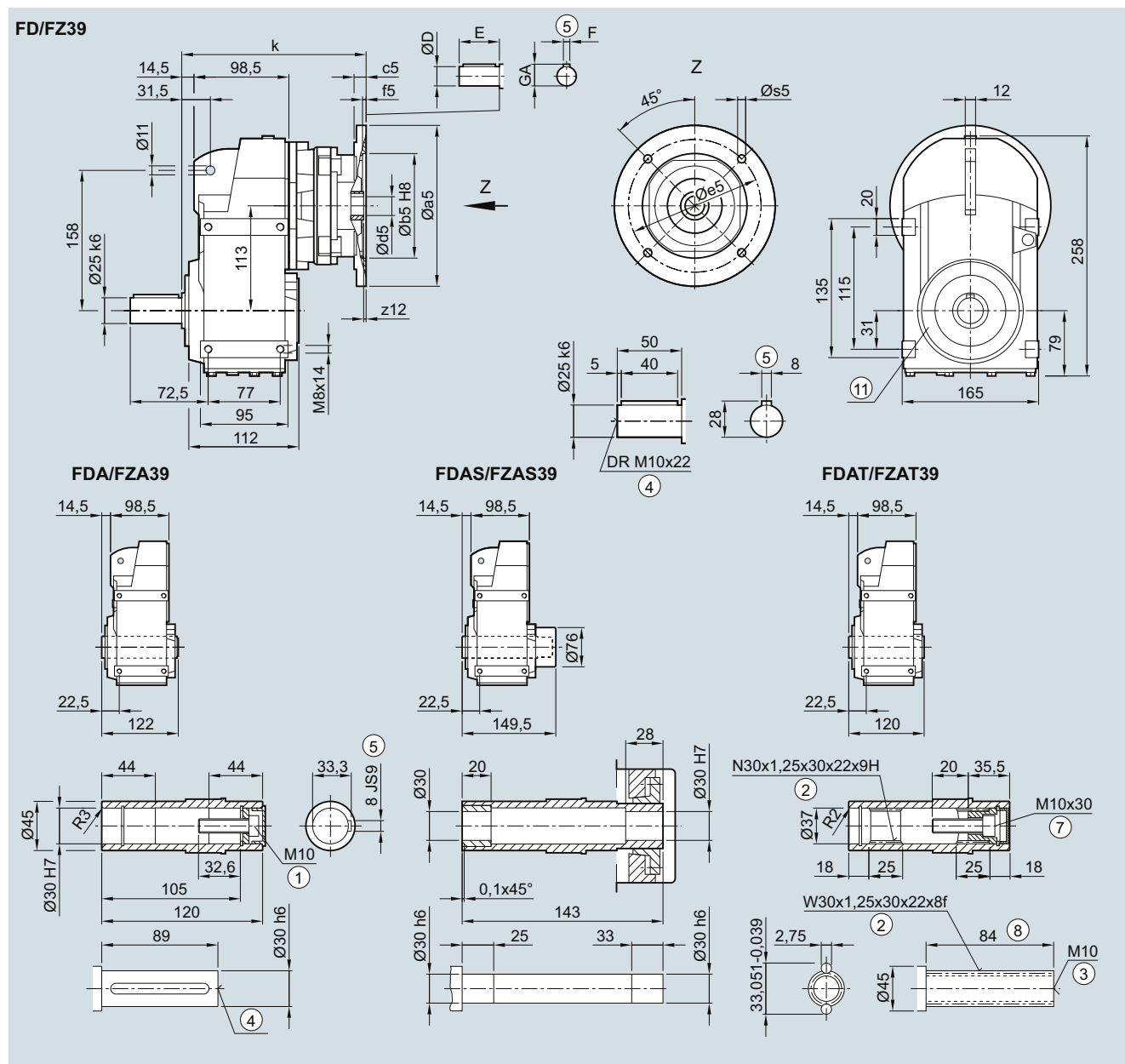

Adapter	a5	b5	c5	f5	e5	s5	z12	d5/D	E	F	GA	k
63	140	95	12	4.5	115	M8	2.5	11	23	4	12.5	190.5
71	160	110	12	4.5	130	M8	2.5	14	30	5	16.0	190.5
80	200	130	15	4.5	165	M10	4.0	19	40	6	12.5	218.5
90	200	130	15	4.5	165	M10	4.0	24	50	8	27.0	218.5
100	250	180	14	5.0	215	M12x21	7.5	28	60	8	31.0	273.0
112	250	180	14	5.0	215	M12x21	7.5	28	60	8	31.0	273.0

① ISO 4014

② DIN 5480

③ DIN 332-D

④ DIN 332

⑤ Feather key/keyway DIN 6885

⑦ ISO 4762

⑧ Without locating shoulder +1 mm

⑨ Use bores only for housing flange design

SIMOGEAR Gearboxes

Parallel shaft gearbox with adapter K4

Dimensions

FDAD/FZAD.49 gearbox in a shaft-mounted design

FAD030K4, FADS030K4, FADT030K4

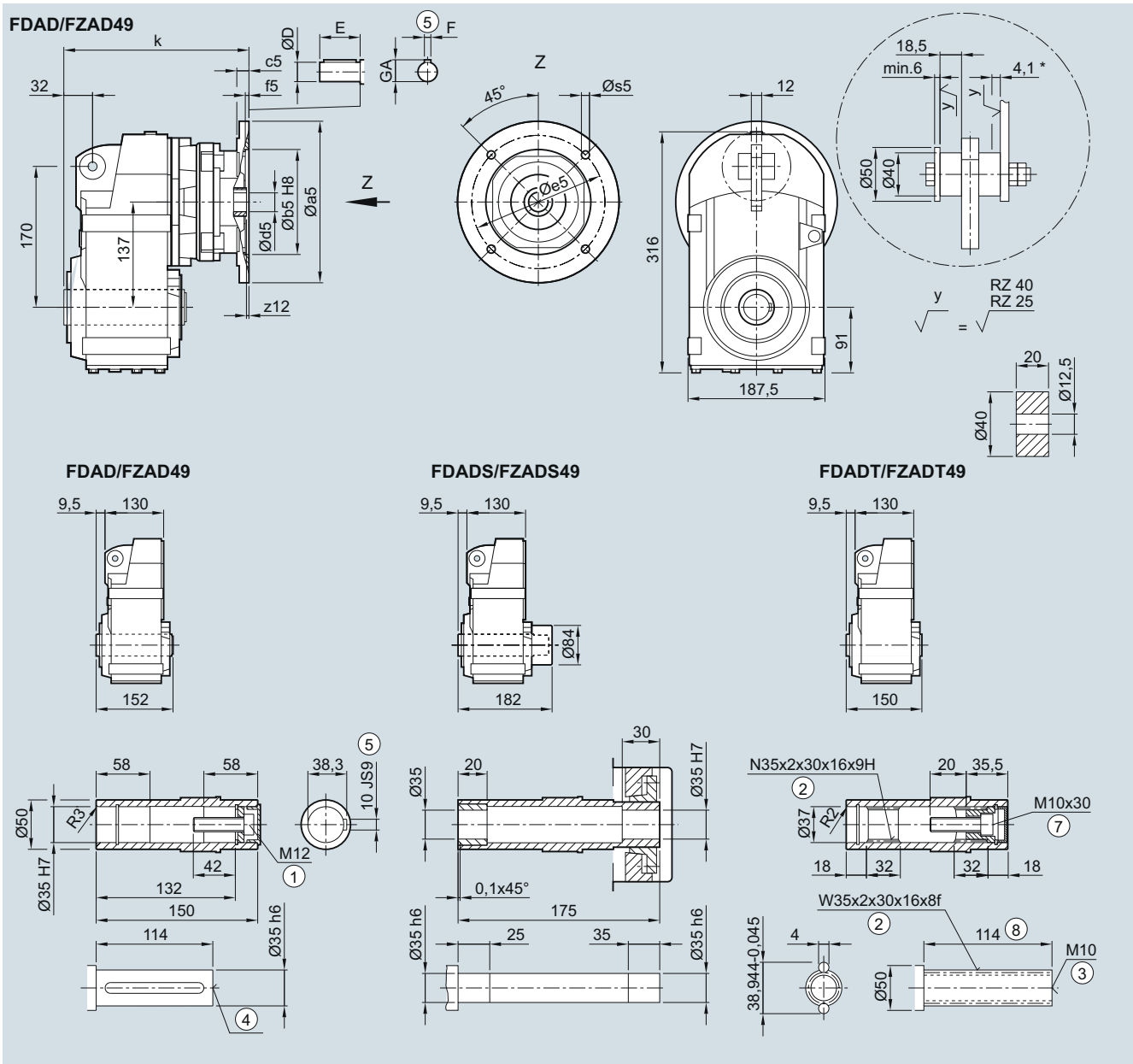

Adapter	a5	b5	c5	f5	e5	s5	z12	d5/D	E	F	GA	k
63	140	95	12	4.5	115	M8	2.5	11	23	4	12.5	207.5
71	160	110	12	4.5	130	M8	2.5	14	30	5	16.0	207.5
80	200	130	15	4.5	165	M10	4.0	19	40	6	12.5	235.5
90	200	130	15	4.5	165	M10	4.0	24	50	8	27.0	235.5
100	250	180	14	5.0	215	M12x21	7.5	28	60	8	31.0	290.0
112	250	180	14	5.0	215	M12x21	7.5	28	60	8	31.0	290.0
132	300	230	12	6.0	265	M12x20	3.0	38	80	10	41.0	307.5

① ISO 4014 ② DIN 5480 ③ DIN 332-D ④ DIN 332 ⑤ Feather key/keyway DIN 6885 ⑦ ISO 4762 ⑥ Without locating shoulder +1 mm

* Spring compression at max. torque

FD.Z./FZ.Z.49 gearbox in a housing flange design

FDZ030K4, FAZ030K4, FAZS030K4, FAZT030K4

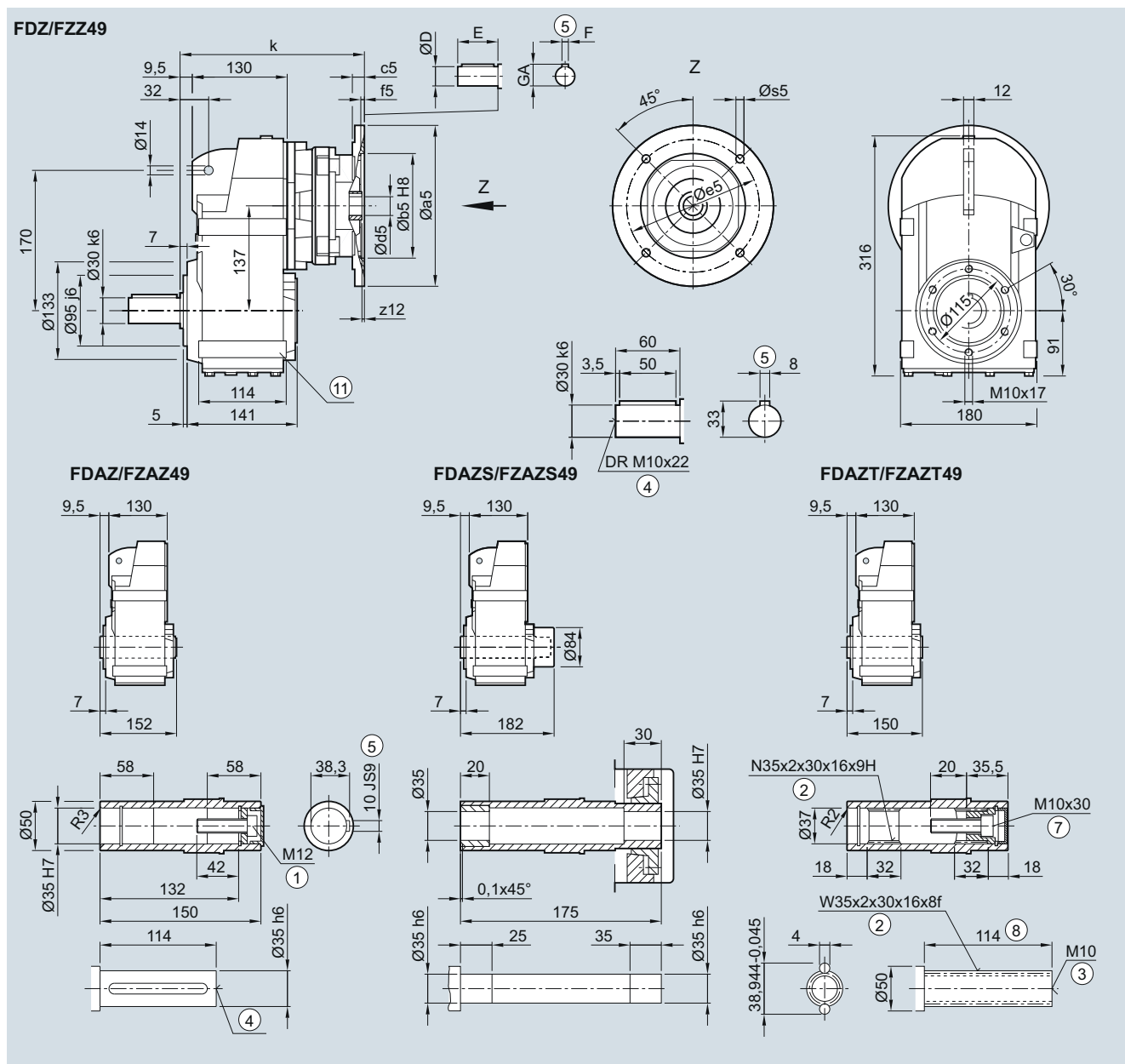

Adapter	a5	b5	c5	f5	e5	s5	z12	d5/D	E	F	GA	k
63	140	95	12	4.5	115	M8	2.5	11	23	4	12.5	207.5
71	160	110	12	4.5	130	M8	2.5	14	30	5	16.0	207.5
80	200	130	15	4.5	165	M10	4.0	19	40	6	12.5	235.5
90	200	130	15	4.5	165	M10	4.0	24	50	8	27.0	235.5
100	250	180	14	5.0	215	M12x21	7.5	28	60	8	31.0	290.0
112	250	180	14	5.0	215	M12x21	7.5	28	60	8	31.0	290.0
132	300	230	12	6.0	265	M12x20	3.0	38	80	10	41.0	307.5

① ISO 4014

② DIN 5480

③ DIN 332-D

④ DIN 332

⑤ Feather key/keyway DIN 6885

⑦ ISO 4762

⑧ Without locating shoulder +1 mm

⑨ Use bores only for foot-mounted design

SIMOGEAR Gearboxes

Parallel shaft gearbox with adapter K4

Dimensions

FD.F./FZ.F.49 gearbox in a flange-mounted design

FF030K4, FAF030K4, FAFS030K4, FAFT030K4

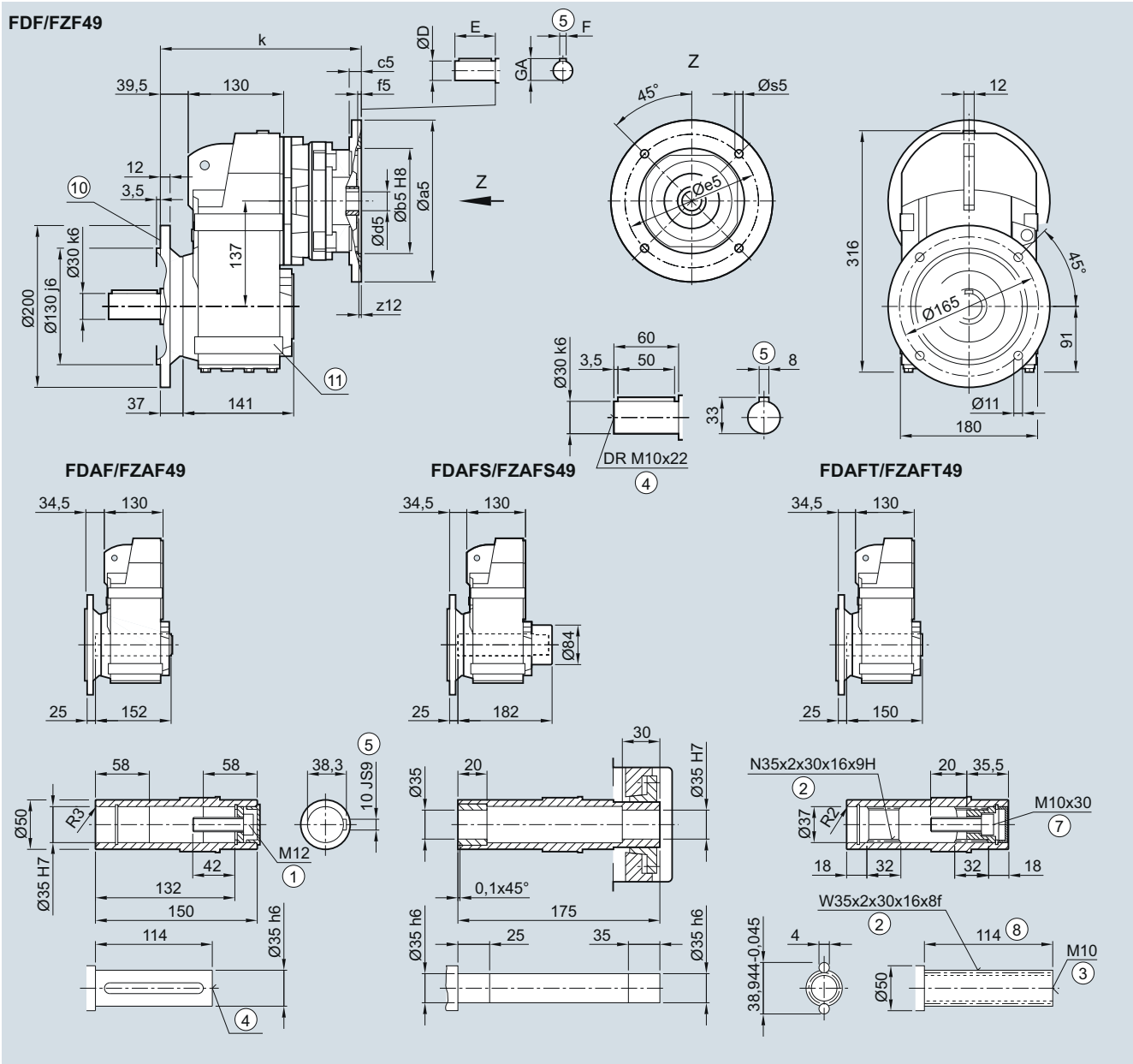

Adapter	a5	b5	c5	f5	e5	s5	z12	d5/D	E	F	GA	k
63	140	95	12	4.5	115	M8	2.5	11.0	23	4	12.5	237.5
71	160	110	12	4.5	130	M8	2.5	14.0	30	5	16.0	237.5
80	200	130	15	4.5	165	M10	4.0	19.0	40	6	12.5	265.5
90	200	130	15	4.5	165	M10	4.0	24.0	50	8	27.0	265.5
100	250	180	14	5.0	215	M12x21	7.5	28.0	60	8	31.0	320.0
112	250	180	14	5.0	215	M12x21	7.5	28.0	60	8	31.0	320.0
132	300	230	12	6.0	265	M12x20	3.0	38.0	80	10	41.0	337.5

① ISO 4014 ② DIN 5480 ③ DIN 332-D ④ DIN 332 ⑤ Feather key/keyway DIN 6885
 ⑦ ISO 4762 ⑥ Without locating shoulder +1 mm ⑩ For inner contour, see page 4/129 ⑪ Use bores only for foot-mounted design

FD../FZ..49 gearbox in a foot-mounted design

F030K4, FA030K4, FAS030K4, FAT030K4

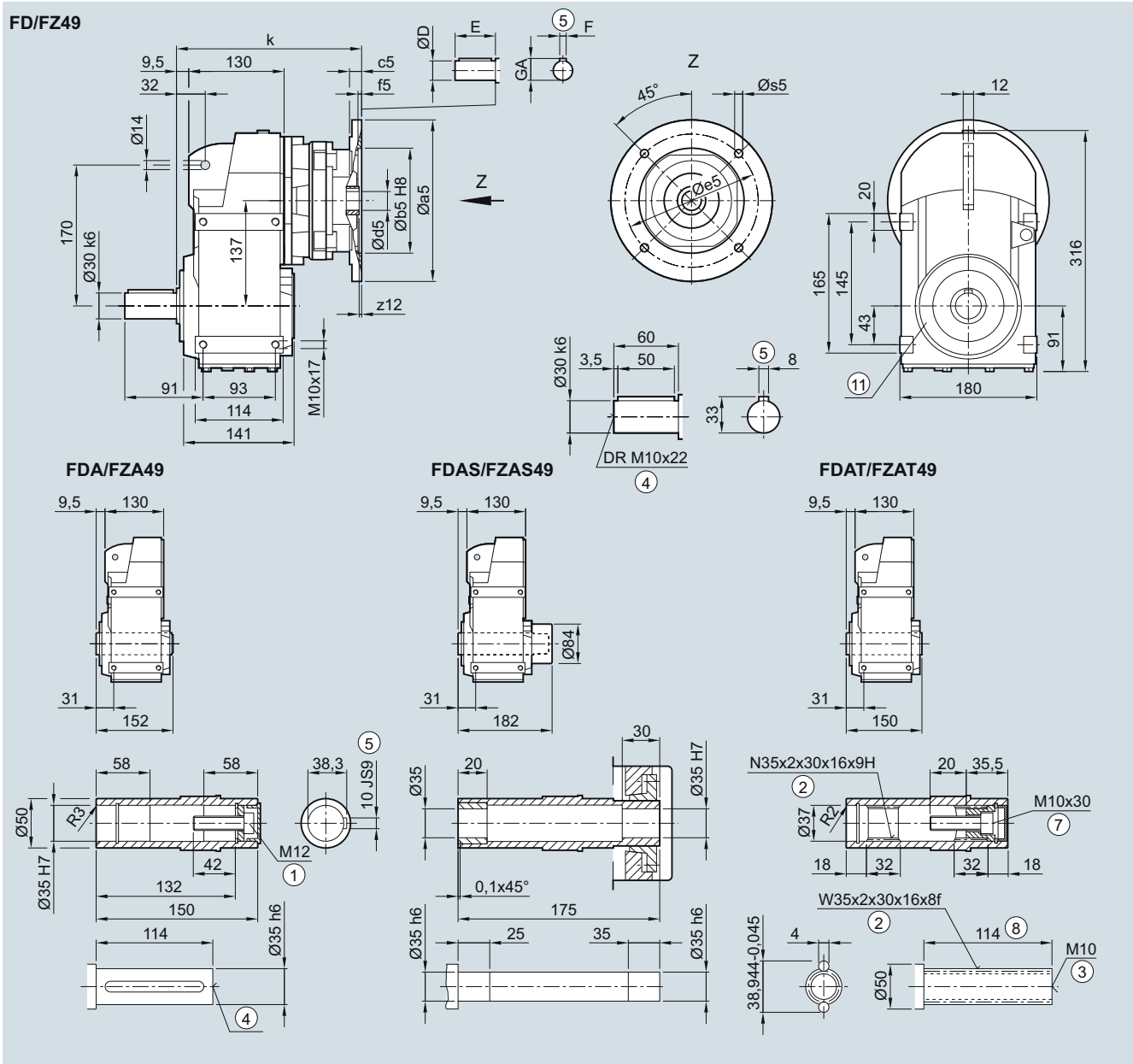

Adapter	a5	b5	c5	f5	e5	s5	z12	d5/D	E	F	GA	k
63	140	95	12	4.5	115	M8	2.5	11	23	4	12.5	207.5
71	160	110	12	4.5	130	M8	2.5	14	30	5	16.0	207.5
80	200	130	15	4.5	165	M10	4.0	19	40	6	12.5	235.5
90	200	130	15	4.5	165	M10	4.0	24	50	8	27.0	235.5
100	250	180	14	5.0	215	M12x21	7.5	28	60	8	31.0	290.0
112	250	180	14	5.0	215	M12x21	7.5	28	60	8	31.0	290.0
132	300	230	12	6.0	265	M12x20	3.0	38	80	10	41.0	307.5

① ISO 4014 ② DIN 5480 ③ DIN 332-D ④ DIN 332
 ⑤ Feather key/keyway DIN 6885 ⑦ ISO 4762 ⑧ Without locating shoulder +1 mm ⑨ Use bores only for housing flange design

SIMOGEAR Gearboxes

Parallel shaft gearbox with adapter K4

Dimensions

FDAD/FZAD.69 gearbox in a shaft-mounted design

FAD030K4, FADS030K4, FADT030K4

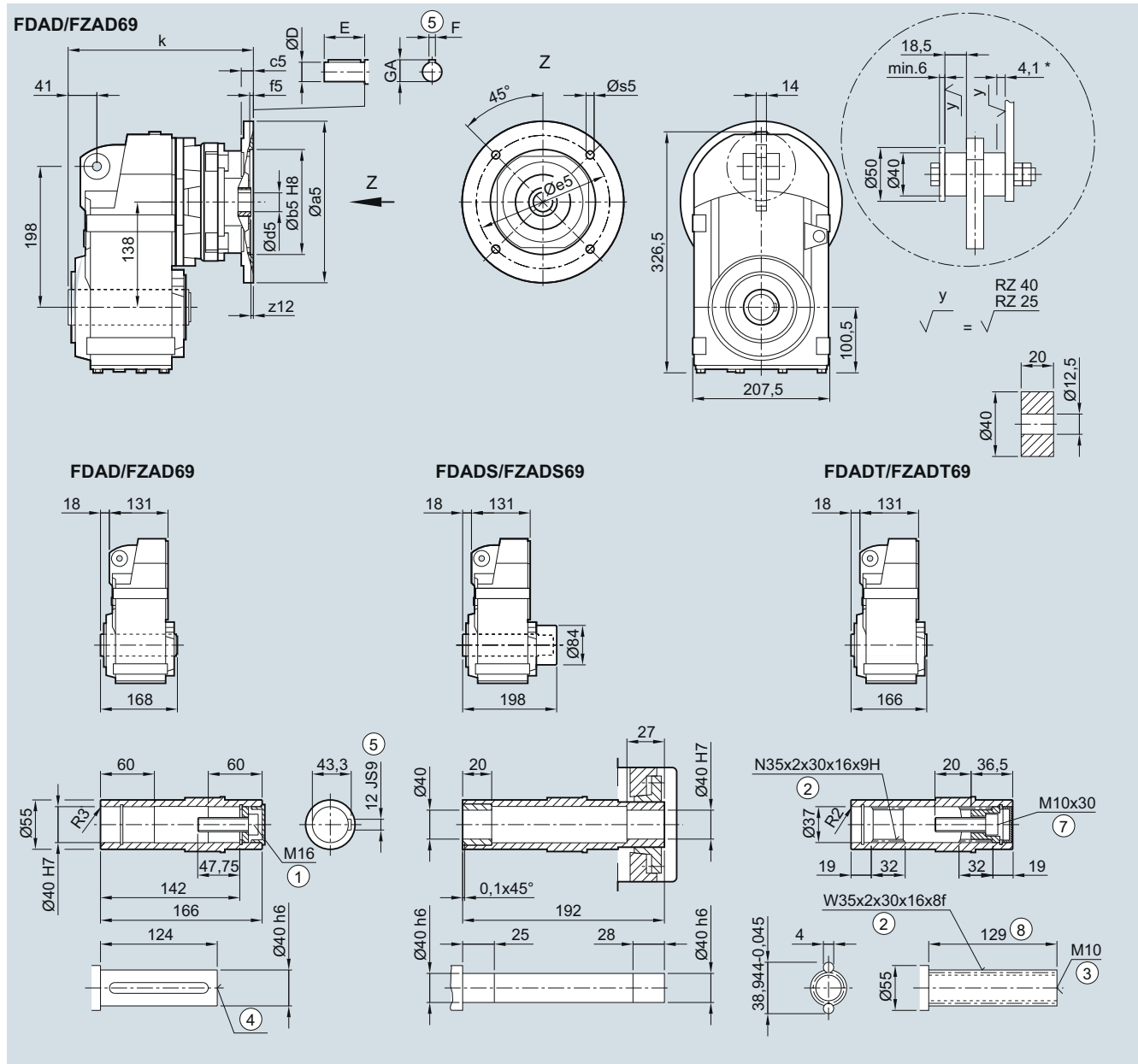

Adapter	a5	b5	c5	f5	e5	s5	z12	d5/D	E	F	GA	k
63	140	95	12	4.5	115	M8	2.5	11	23	4	12.5	217.0
71	160	110	12	4.5	130	M8	2.5	14	30	5	16.0	217.0
80	200	130	15	4.5	165	M10	4.0	19	40	6	12.5	245.0
90	200	130	15	4.5	165	M10	4.0	24	50	8	27.0	245.0
100	250	180	14	5.0	215	M12x21	7.5	28	60	8	31.0	299.5
112	250	180	14	5.0	215	M12x21	7.5	28	60	8	31.0	299.5
132	300	230	12	6.0	265	M12x20	3.0	38	80	10	41.0	317.0

① ISO 4014 ② DIN 5480 ③ DIN 332-D ④ DIN 332 ⑤ Feather key/keyway DIN 6885 ⑦ ISO 4762 ⑧ Without locating shoulder +1 mm

* Spring compression at max. torque

FD.Z./FZ.Z.69 gearbox in a housing flange design

FZ030K4, FAZ030K4, FAZS030K4, FAZT030K4

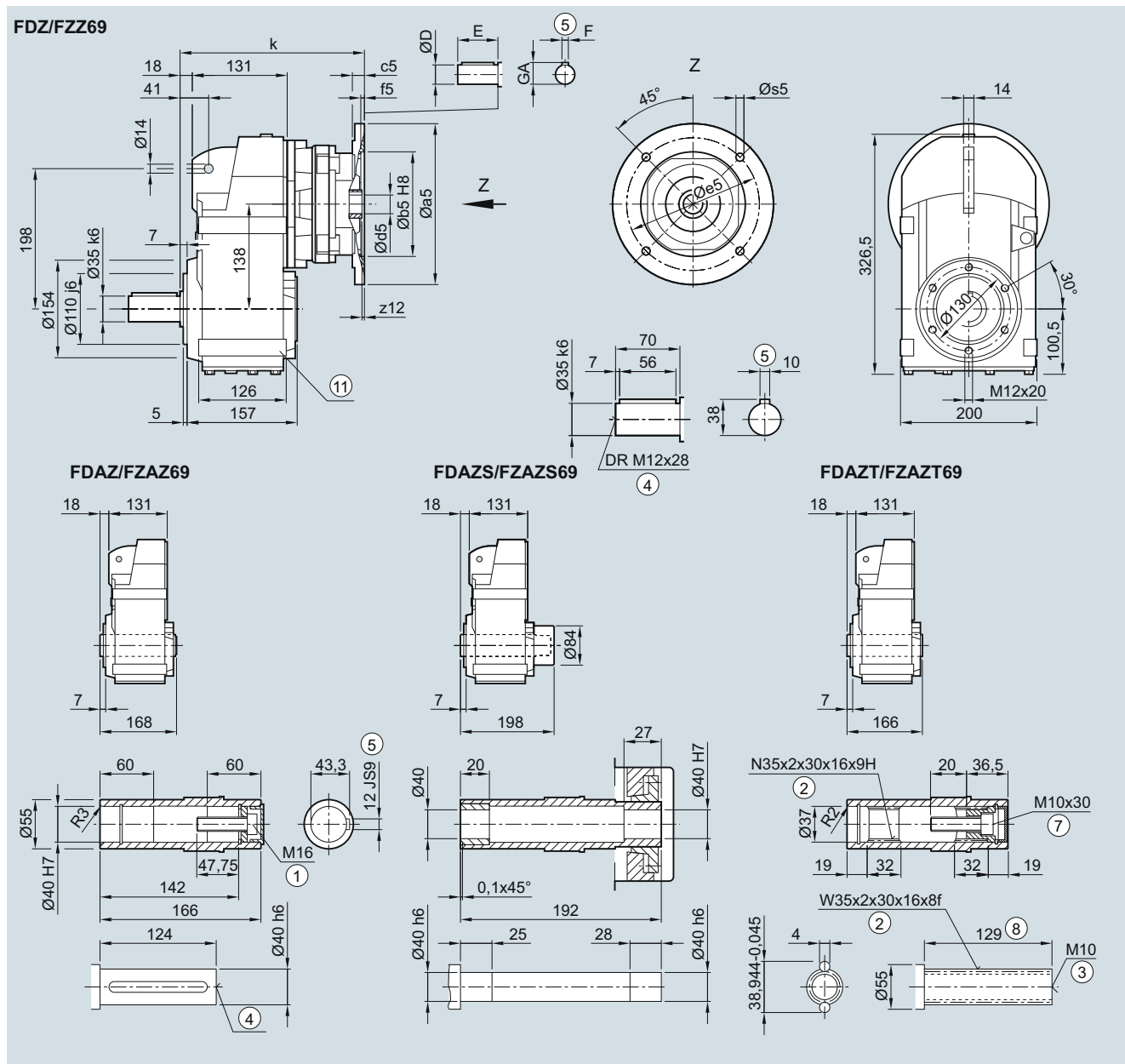

Adapter	a5	b5	c5	f5	e5	s5	z12	d5/D	E	F	GA	k
63	140	95	12	4.5	115	M8	2.5	11	23	4	12.5	217.0
71	160	110	12	4.5	130	M8	2.5	14	30	5	16.0	217.0
80	200	130	15	4.5	165	M10	4.0	19	40	6	12.5	245.0
90	200	130	15	4.5	165	M10	4.0	24	50	8	27.0	245.0
100	250	180	14	5.0	215	M12x21	7.5	28	60	8	31.0	299.5
112	250	180	14	5.0	215	M12x21	7.5	28	60	8	31.0	299.5
132	300	230	12	6.0	265	M12x20	3.0	38	80	10	41.0	317.0

① ISO 4014 ② DIN 5480 ③ DIN 332-D ④ DIN 332
 ⑤ Feather key/keyway DIN 6885 ⑦ ISO 4762 ⑧ Without locating shoulder +1 mm ⑩ Use bores only for foot-mounted design

SIMOGEAR Gearboxes

Parallel shaft gearbox with adapter K4

Dimensions

FD.F./FZ.F.69 gearbox in a flange-mounted design

FF030K4, FAF030K4, FAFS030K4, FAFT030K4

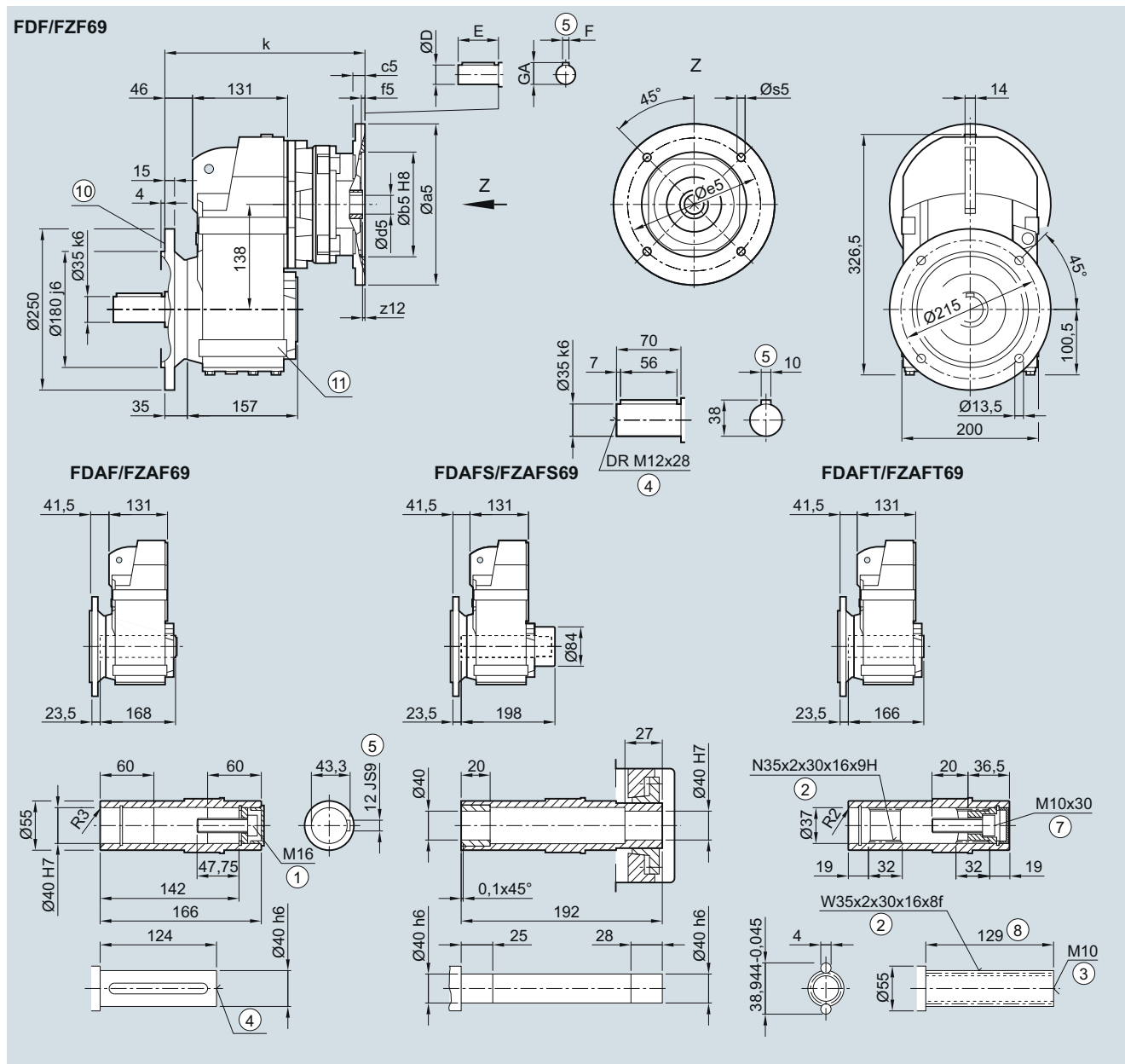

Adapter	a5	b5	c5	f5	e5	s5	z12	d5/D	E	F	GA	k
63	140	95	12	4.5	115	M8	2.5	11.0	23	4	12.5	245.0
71	160	110	12	4.5	130	M8	2.5	14.0	30	5	16.0	245.0
80	200	130	15	4.5	165	M10	4.0	19.0	40	6	12.5	273.0
90	200	130	15	4.5	165	M10	4.0	24.0	50	8	27.0	273.0
100	250	180	14	5.0	215	M12x21	7.5	28.0	60	8	31.0	327.5
112	250	180	14	5.0	215	M12x21	7.5	28.0	60	8	31.0	327.5
132	300	230	12	6.0	265	M12x20	3.0	38.0	80	10	41.0	345.0

① ISO 4014

② DIN 5480

③ DIN 332-D

④ DIN 332

⑤ Feather key/keyway DIN 6885

⑦ ISO 4762

⑥ Without locating shoulder +1 mm

⑩ For inner contour, see page 4/129

⑪ Use bores only for foot-mounted design

FD../FZ..69 gearbox in a foot-mounted design

F030K4, FA030K4, FAS030K4, FAT030K4

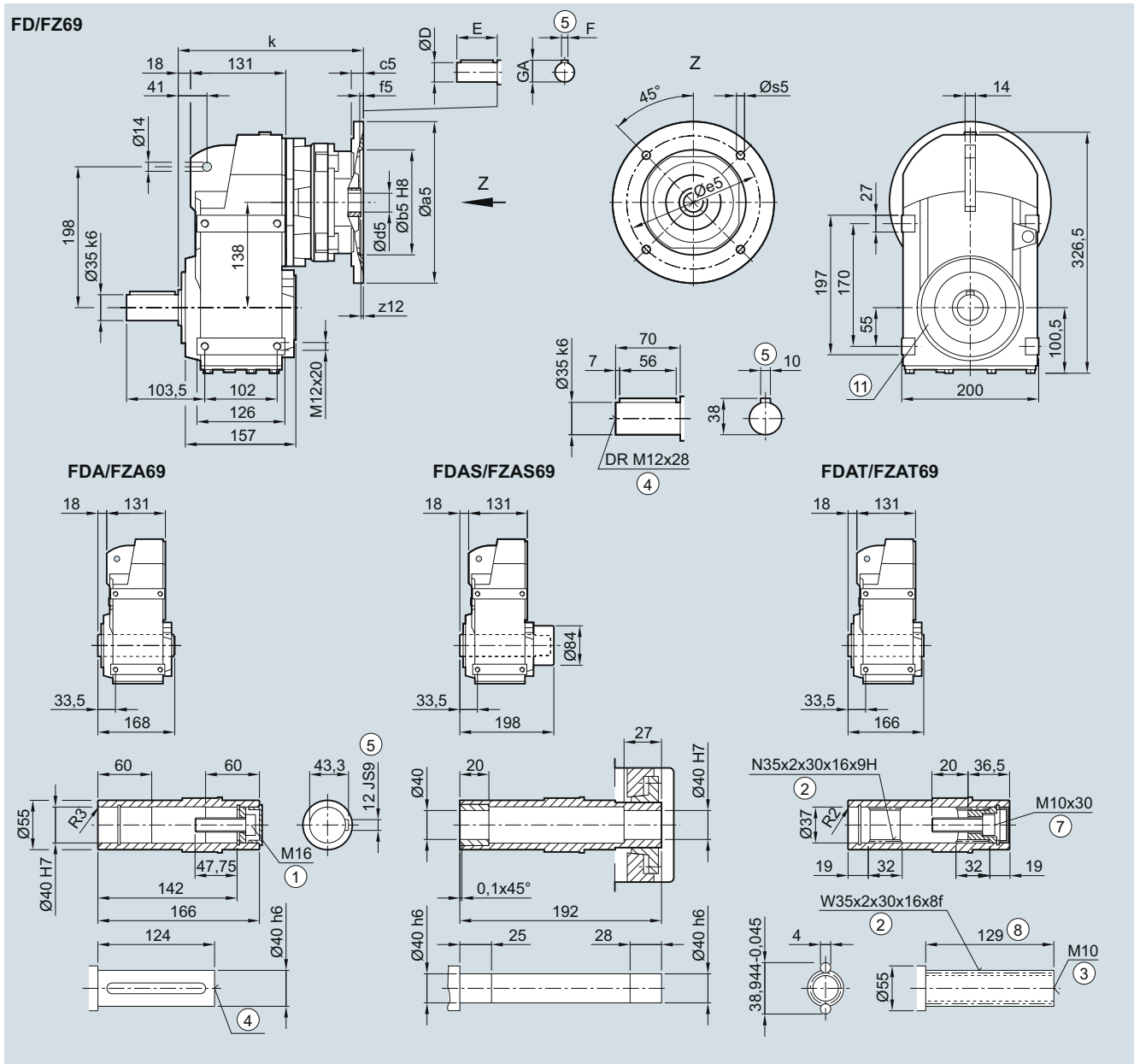

Adapter	a5	b5	c5	f5	e5	s5	z12	d5/D	E	F	GA	k
63	140	95	12	4.5	115	M8	2.5	11	23	4	12.5	217.0
71	160	110	12	4.5	130	M8	2.5	14	30	5	16.0	217.0
80	200	130	15	4.5	165	M10	4.0	19	40	6	12.5	245.0
90	200	130	15	4.5	165	M10	4.0	24	50	8	27.0	245.0
100	250	180	14	5.0	215	M12x21	7.5	28	60	8	31.0	299.5
112	250	180	14	5.0	215	M12x21	7.5	28	60	8	31.0	299.5
132	300	230	12	6.0	265	M12x20	3.0	38	80	10	41.0	317.0

① ISO 4014

② DIN 5480

③ DIN 332-D

④ DIN 332

⑤ Feather key/keyway DIN 6885

⑦ ISO 4762

⑧ Without locating shoulder +1 mm

⑨ Use bores only for housing flange design

SIMOGEAR Gearboxes

Parallel shaft gearbox with adapter K4

Dimensions

FDAD/FZAD.79 gearbox in a shaft-mounted design

FAD030K4, FADS030K4, FADT030K4

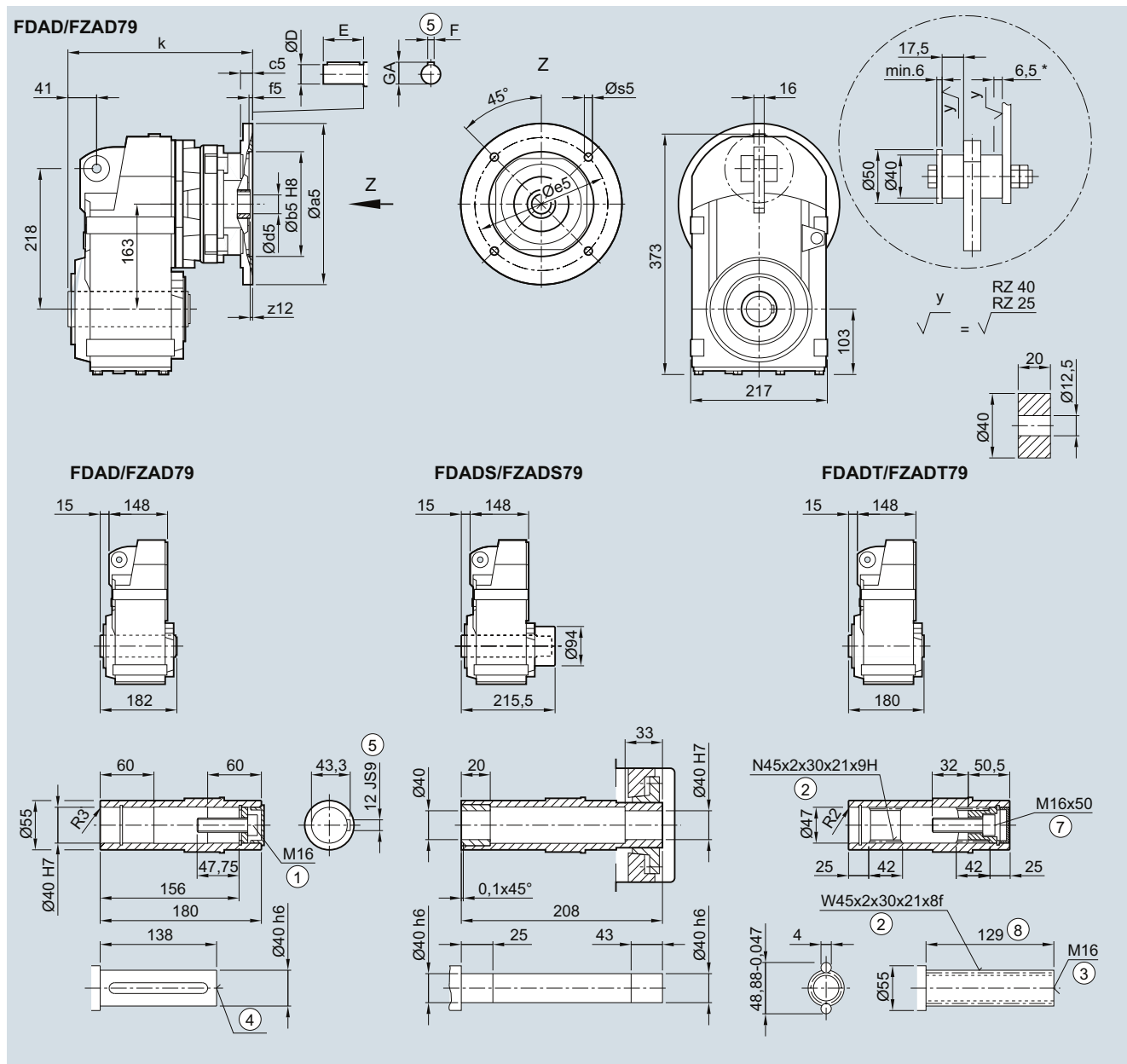

Adapter	a5	b5	c5	f5	e5	s5	z12	d5/D	E	F	GA	k
71	160	110	12	4.5	130	M8	2.5	14	30	5	16.0	229.0
80	200	130	15	4.5	165	M10	4.0	19	40	6	12.5	253.0
90	200	130	15	4.5	165	M10	4.0	24	50	8	27.0	253.0
100	250	180	14	5.0	215	M12x21	7.5	28	60	8	31.0	307.5
112	250	180	14	5.0	215	M12x21	7.5	28	60	8	31.0	307.5
132	300	230	12	6.0	265	M12x20	3.0	38	80	10	41.0	325.0
160	350	250	15	6.0	300	M16x25	3.0	42	110	12	45.0	355.0

① ISO 4014 ② DIN 5480 ③ DIN 332-D ④ DIN 332 ⑤ Feather key/keyway DIN 6885 ⑦ ISO 4762 ⑧ Without locating shoulder +1 mm

* Spring compression at max. torque

FD.Z./FZ.Z.79 gearbox in a housing flange design

FDZ030K4, FAZ030K4, FAZS030K4, FAZT030K4

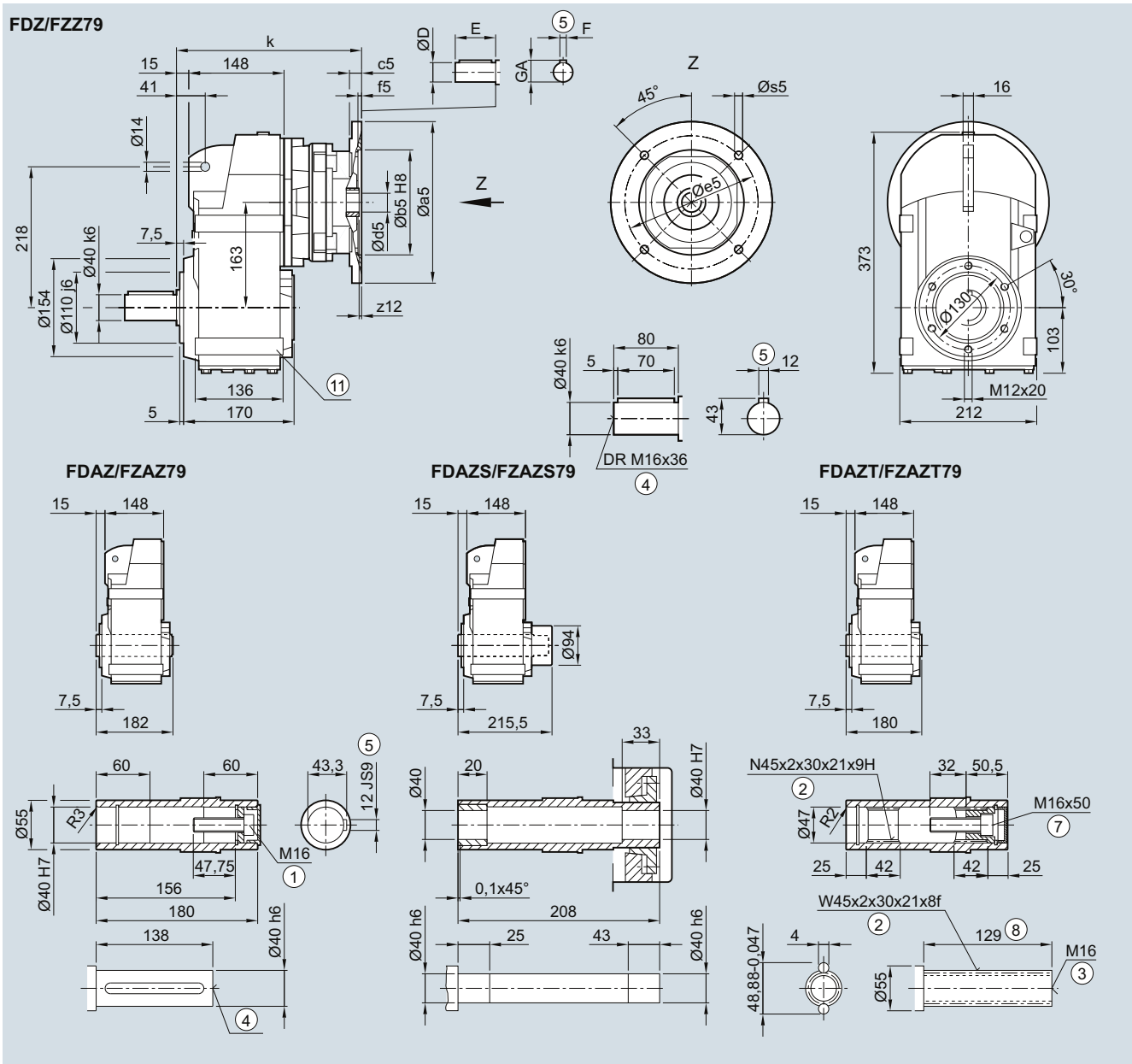

Adapter	a5	b5	c5	f5	e5	s5	z12	d5/D	E	F	GA	k
71	160	110	12	4.5	130	M8	2.5	14	30	5	16.0	229.0
80	200	130	15	4.5	165	M10	4.0	19	40	6	12.5	253.0
90	200	130	15	4.5	165	M10	4.0	24	50	8	27.0	253.0
100	250	180	14	5.0	215	M12x21	7.5	28	60	8	31.0	307.5
112	250	180	14	5.0	215	M12x21	7.5	28	60	8	31.0	307.5
132	300	230	12	6.0	265	M12x20	3.0	38	80	10	41.0	325.0
160	350	250	15	6.0	300	M16x25	3.0	42	110	12	45.0	355.0

① ISO 4014

② DIN 5480

③ DIN 332-D

④ DIN 332

⑤ Feather key/keyway DIN 6885

⑦ ISO 4762

⑧ Without locating shoulder +1 mm

⑨ Use bores only for foot-mounted design

SIMOGEAR Gearboxes

Parallel shaft gearbox with adapter K4

Dimensions

FD.F./FZ.F.79 gearbox in a flange-mounted design

FF030K4, FAF030K4, FAFS030K4, FAFT030K4

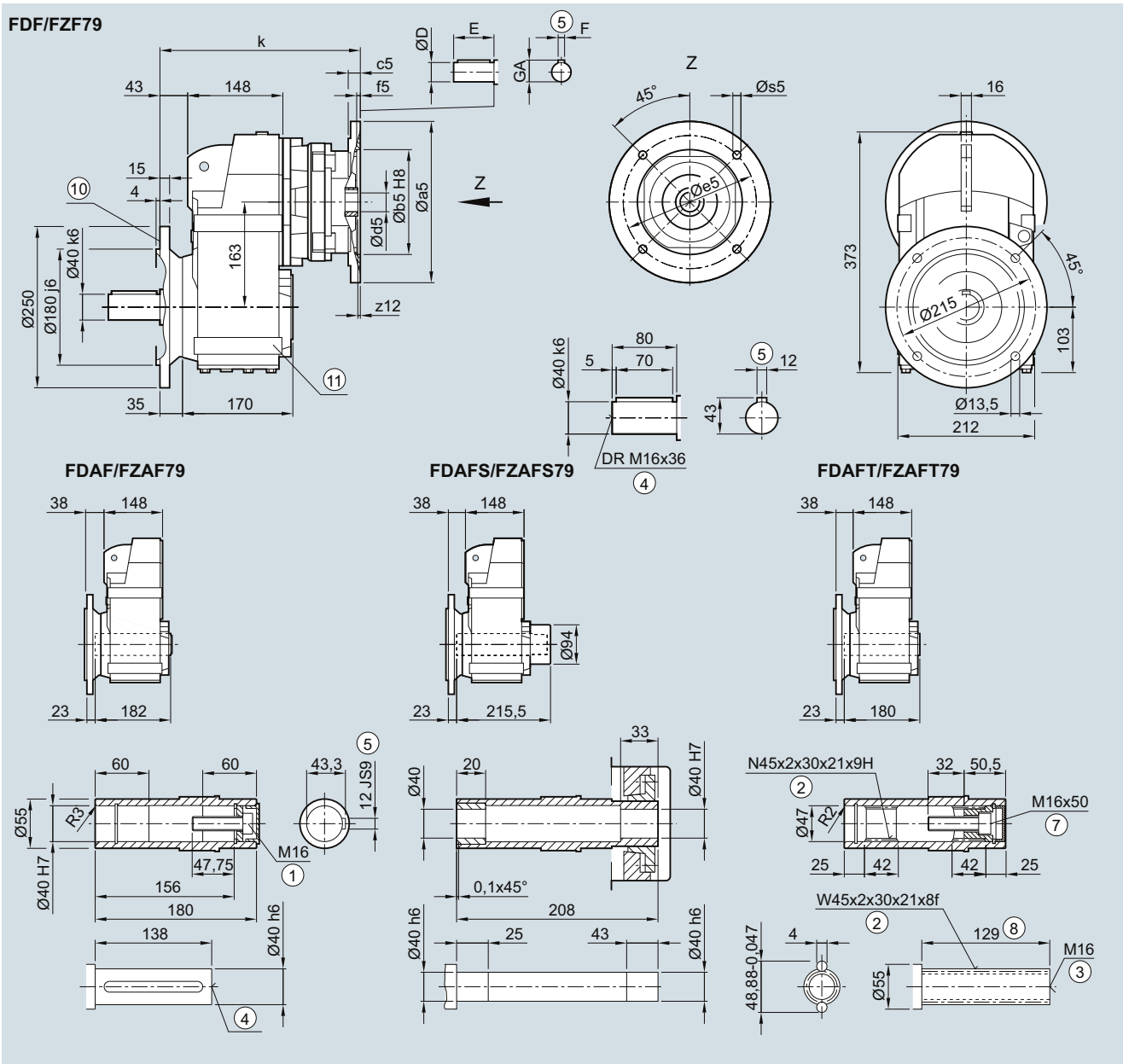

Adapter	a5	b5	c5	f5	e5	s5	z12	d5/D	E	F	GA	k
71	160	110	12	4.5	130	M8	2.5	14.0	30	5	16.0	257.0
80	200	130	15	4.5	165	M10	4.0	19.0	40	6	12.5	281.0
90	200	130	15	4.5	165	M10	4.0	24.0	50	8	27.0	281.0
100	250	180	14	5.0	215	M12x21	7.5	28.0	60	8	31.0	335.5
112	250	180	14	5.0	215	M12x21	7.5	28.0	60	8	31.0	335.5
132	300	230	12	6.0	265	M12x20	3.0	38.0	80	10	41.0	353.0
160	350	250	15	6.0	300	M16x25	3.0	42.0	110	12	45.0	383.0

① ISO 4014 ② DIN 5480 ③ DIN 332-D ④ DIN 332 ⑤ Feather key/keyway DIN 6885
 ⑦ ISO 4762 ⑥ Without locating shoulder +1 mm ⑩ For inner contour, see page 4/129 ⑧ Use bores only for foot-mounted design

FD../FZ..79 gearbox in a foot-mounted design

F030K4, FA030K4, FAS030K4, FAT030K4

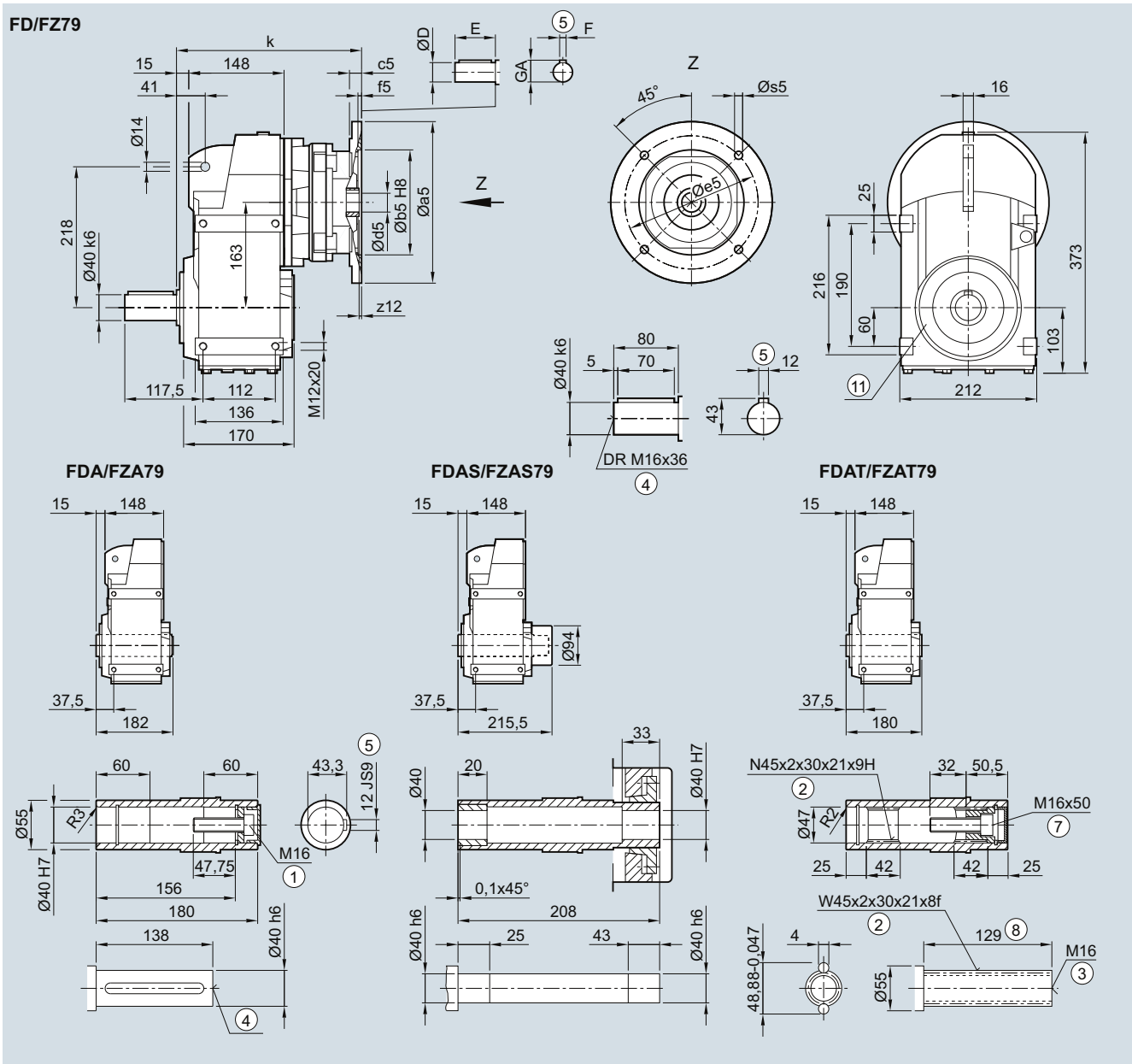

Adapter	a5	b5	c5	f5	e5	s5	z12	d5/D	E	F	GA	k
71	160	110	12	4.5	130	M8	2.5	14	30	5	16.0	229.0
80	200	130	15	4.5	165	M10	4.0	19	40	6	12.5	253.0
90	200	130	15	4.5	165	M10	4.0	24	50	8	27.0	253.0
100	250	180	14	5.0	215	M12x21	7.5	28	60	8	31.0	307.5
112	250	180	14	5.0	215	M12x21	7.5	28	60	8	31.0	307.5
132	300	230	12	6.0	265	M12x20	3.0	38	80	10	41.0	325.0
160	350	250	15	6.0	300	M16x25	3.0	42	110	12	45.0	355.0

① ISO 4014

② DIN 5480

③ DIN 332-D

④ DIN 332

⑤ Feather key/keyway DIN 6885

⑦ ISO 4762

⑧ Without locating shoulder +1 mm

⑨ Use bores only for housing flange design

SIMOGEAR Gearboxes

Parallel shaft gearbox with adapter K4

Dimensions

FDAD./FZAD.89 gearbox in a shaft-mounted design

FAD030K4, FADS030K4, FADT030K4

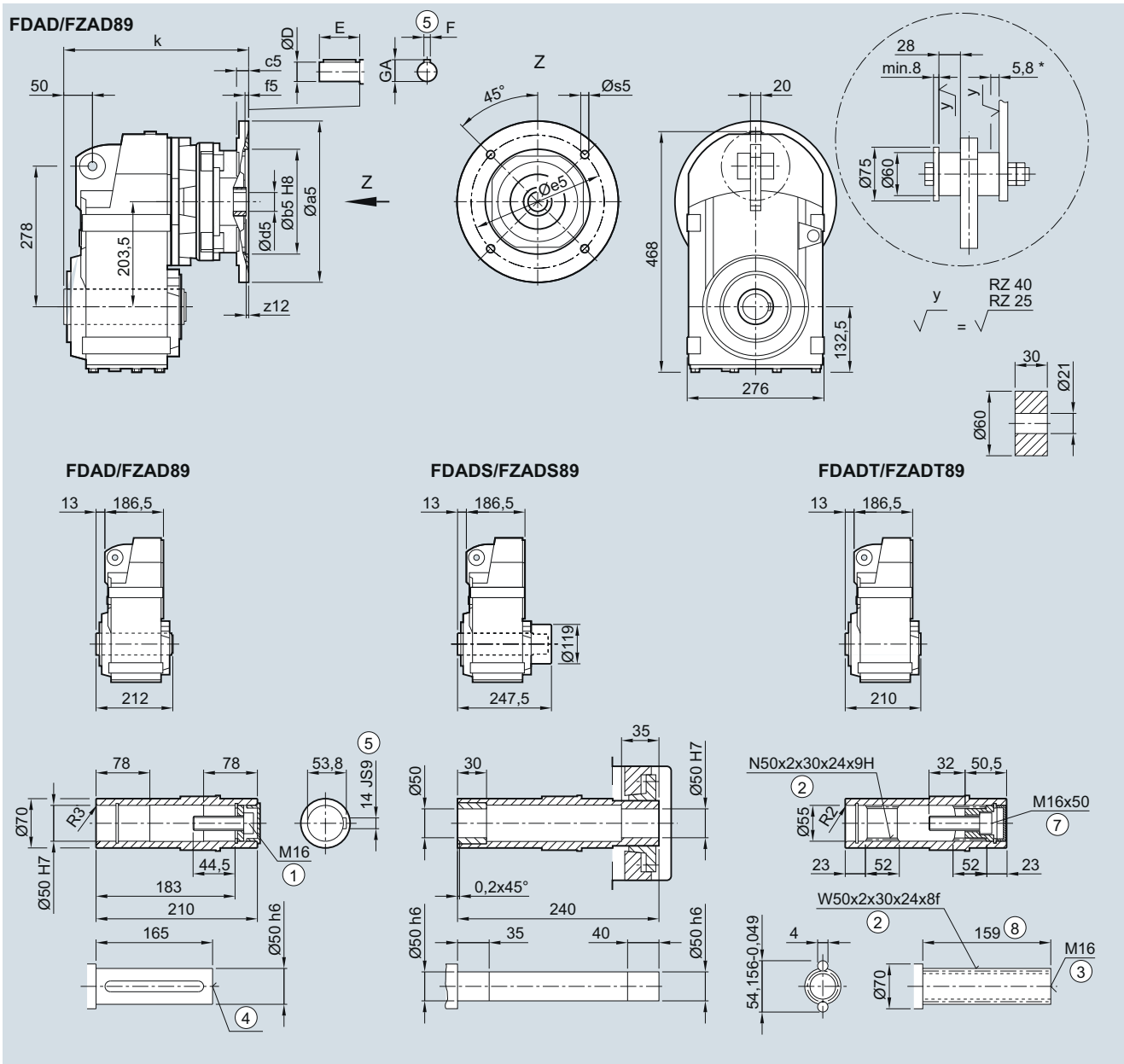

Adapter	a5	b5	c5	f5	e5	s5	z12	d5/D	E	F	GA	k
80	200	130	15	4.5	165	M10	4.0	19	40	6	12.5	276.5
90	200	130	15	4.5	165	M10	4.0	24	50	8	27.0	276.5
100	250	180	14	5.0	215	M12x21	7.5	28	60	8	31.0	327.0
112	250	180	14	5.0	215	M12x21	7.5	28	60	8	31.0	327.0
132	300	230	12	6.0	265	M12x20	3.0	38	80	10	41.0	344.5
160	350	250	15	6.0	300	M16x25	3.0	42	110	12	45.0	374.5

① ISO 4014 ② DIN 5480 ③ DIN 332-D ④ DIN 332 ⑤ Feather key/keyway DIN 6885 ⑦ ISO 4762 ⑧ Without locating shoulder +1 mm

* Spring compression at max. torque

FD.Z./FZ.Z.89 gearbox in a housing flange design

FZ030K4, FAZ030K4, FAZS030K4, FAZT030K4

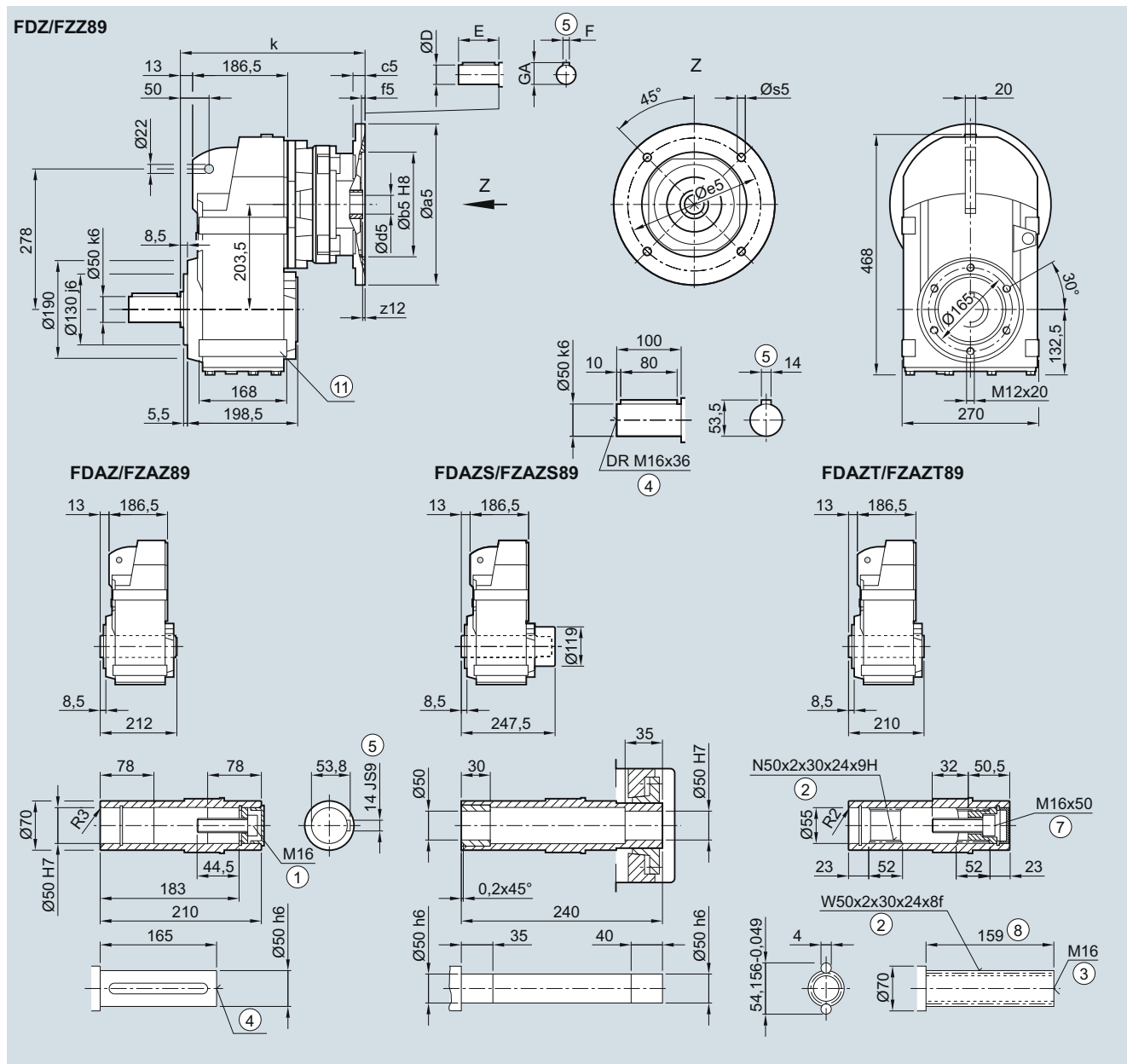

Adapter	a5	b5	c5	f5	e5	s5	z12	d5/D	E	F	GA	k
80	200	130	15	4.5	165	M10	4.0	19	40	6	12.5	276.5
90	200	130	15	4.5	165	M10	4.0	24	50	8	27.0	276.5
100	250	180	14	5.0	215	M12x21	7.5	28	60	8	31.0	327.0
112	250	180	14	5.0	215	M12x21	7.5	28	60	8	31.0	327.0
132	300	230	12	6.0	265	M12x20	3.0	38	80	10	41.0	344.5
160	350	250	15	6.0	300	M16x25	3.0	42	110	12	45.0	374.5

① ISO 4014 ② DIN 5480 ③ DIN 332-D ④ DIN 332
 ⑤ Feather key/keyway DIN 6885 ⑦ ISO 4762 ⑧ Without locating shoulder +1 mm ⑩ Use bores only for foot-mounted design

SIMOGEAR Gearboxes

Parallel shaft gearbox with adapter K4

Dimensions

FD.F./FZ.F.89 gearbox in a flange-mounted design

FF030K4, FAF030K4, FAFS030K4, FAFT030K4

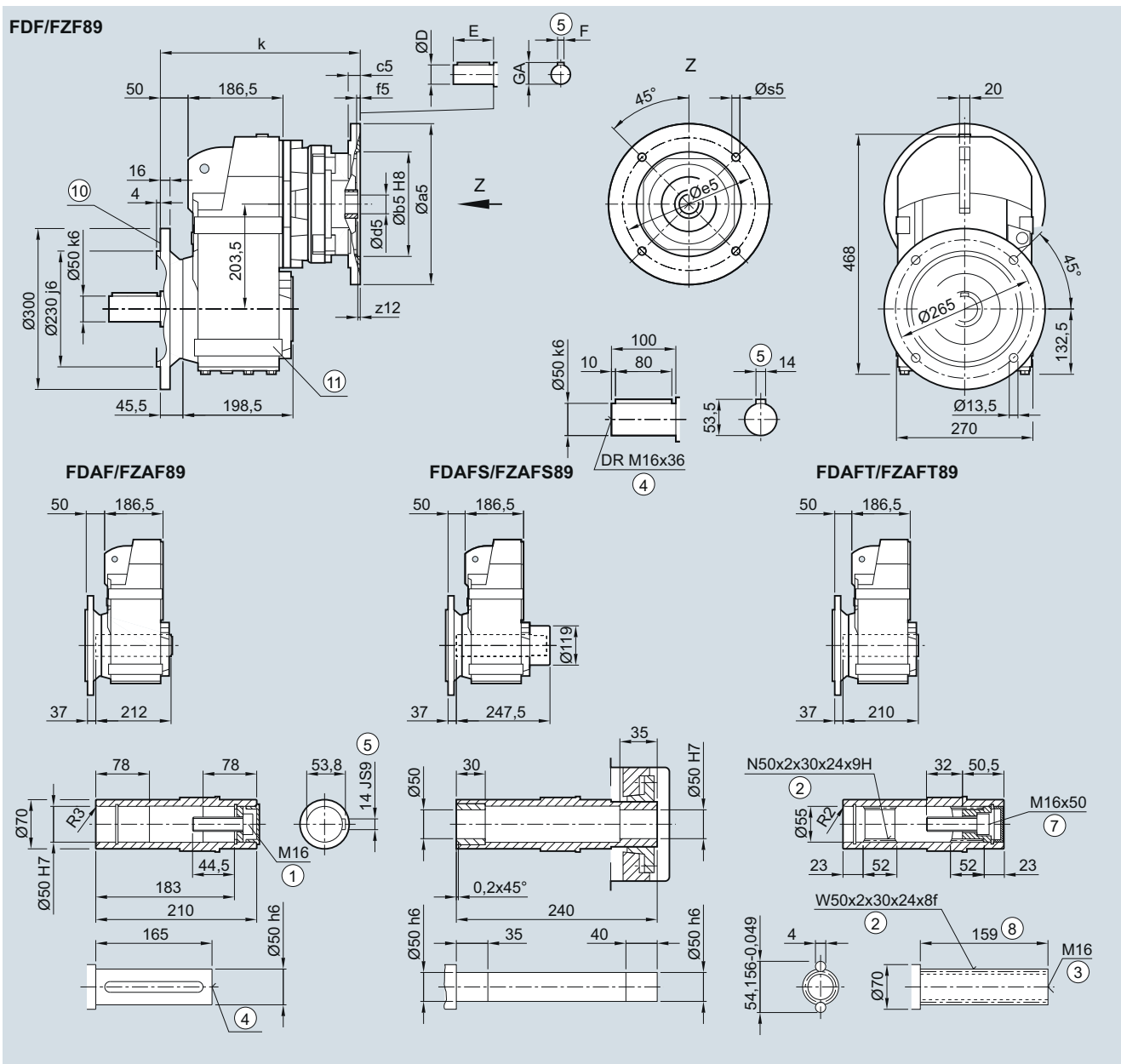

Adapter	a5	b5	c5	f5	e5	s5	z12	d5/D	E	F	GA	k
80	200	130	15	4.5	165	M10	4.0	19.0	40	6	12.5	313.5
90	200	130	15	4.5	165	M10	4.0	24.0	50	8	27.0	313.5
100	250	180	14	5.0	215	M12x21	7.5	28.0	60	8	31.0	364.0
112	250	180	14	5.0	215	M12x21	7.5	28.0	60	8	31.0	364.0
132	300	230	12	6.0	265	M12x20	3.0	38.0	80	10	41.0	381.5
160	350	250	15	6.0	300	M16x25	3.0	42.0	110	12	45.0	411.5

① ISO 4014 ② DIN 5480 ③ DIN 332-D ④ DIN 332 ⑤ Feather key/keyway DIN 6885
 ⑦ ISO 4762 ⑥ Without locating shoulder +1 mm ⑩ For inner contour, see page 4/129 ⑪ Use bores only for foot-mounted design

SIMOGEAR Gearboxes

Parallel shaft gearbox with adapter K4

Dimensions

FD../FZ..89 gearbox in a foot-mounted design

F030K4, FA030K4, FAS030K4, FAT030K4

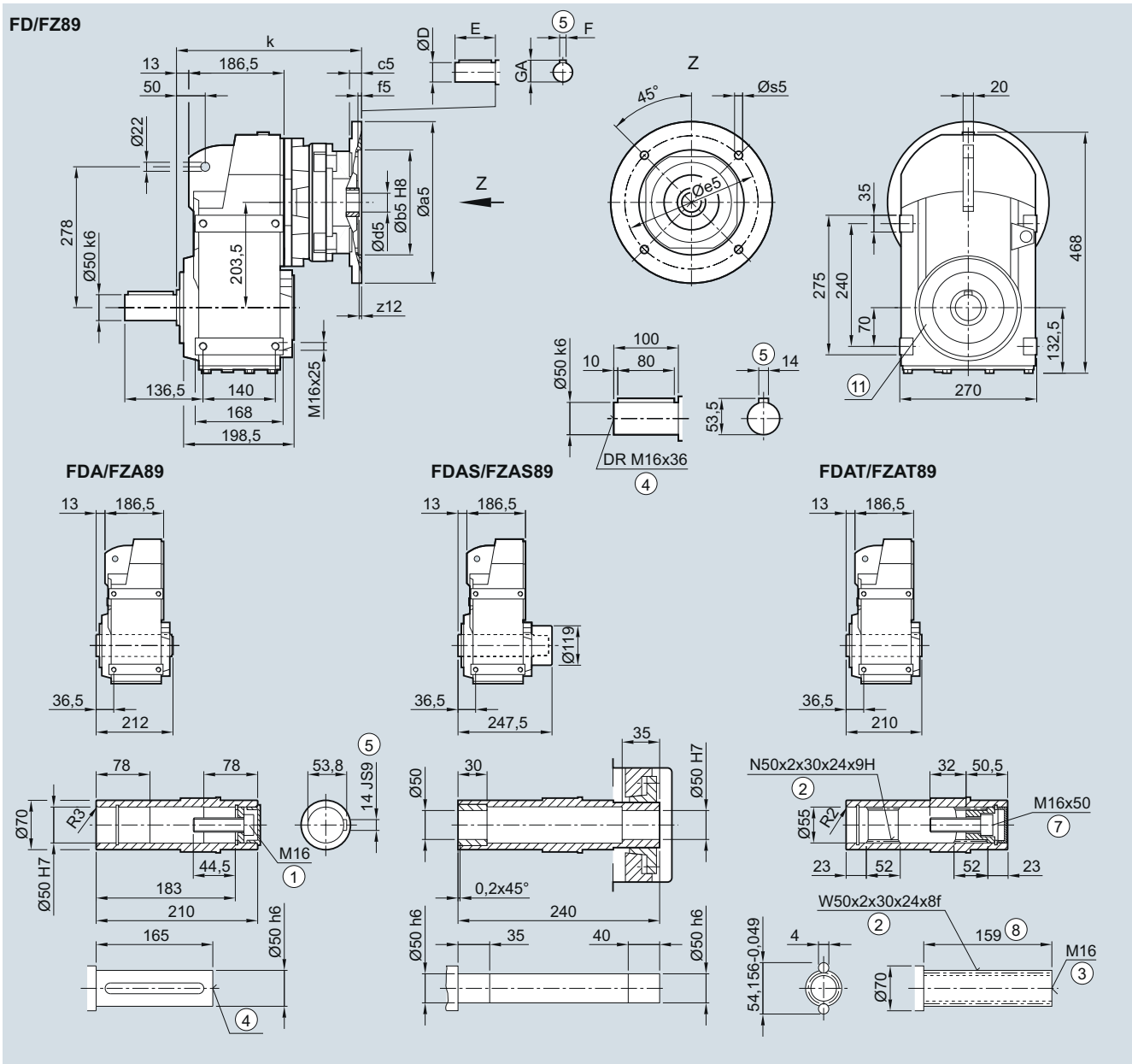

Adapter	a5	b5	c5	f5	e5	s5	z12	d5/D	E	F	GA	k
80	200	130	15	4.5	165	M10	4.0	19	40	6	12.5	276.5
90	200	130	15	4.5	165	M10	4.0	24	50	8	27.0	276.5
100	250	180	14	5.0	215	M12x21	7.5	28	60	8	31.0	327.0
112	250	180	14	5.0	215	M12x21	7.5	28	60	8	31.0	327.0
132	300	230	12	6.0	265	M12x20	3.0	38	80	10	41.0	344.5
160	350	250	15	6.0	300	M16x25	3.0	42	110	12	45.0	374.5

① ISO 4014

② DIN 5480

③ DIN 332-D

④ DIN 332

⑤ Feather key/keyway DIN 6885

⑦ ISO 4762

⑧ Without locating shoulder +1 mm

⑩ Use bores only for housing flange design

SIMOGEAR Gearboxes

Parallel shaft gearbox with adapter K4

Dimensions

FDAD./FZAD.109 gearbox in a shaft-mounted design

FAD030K4, FADS030K4, FADT030K4

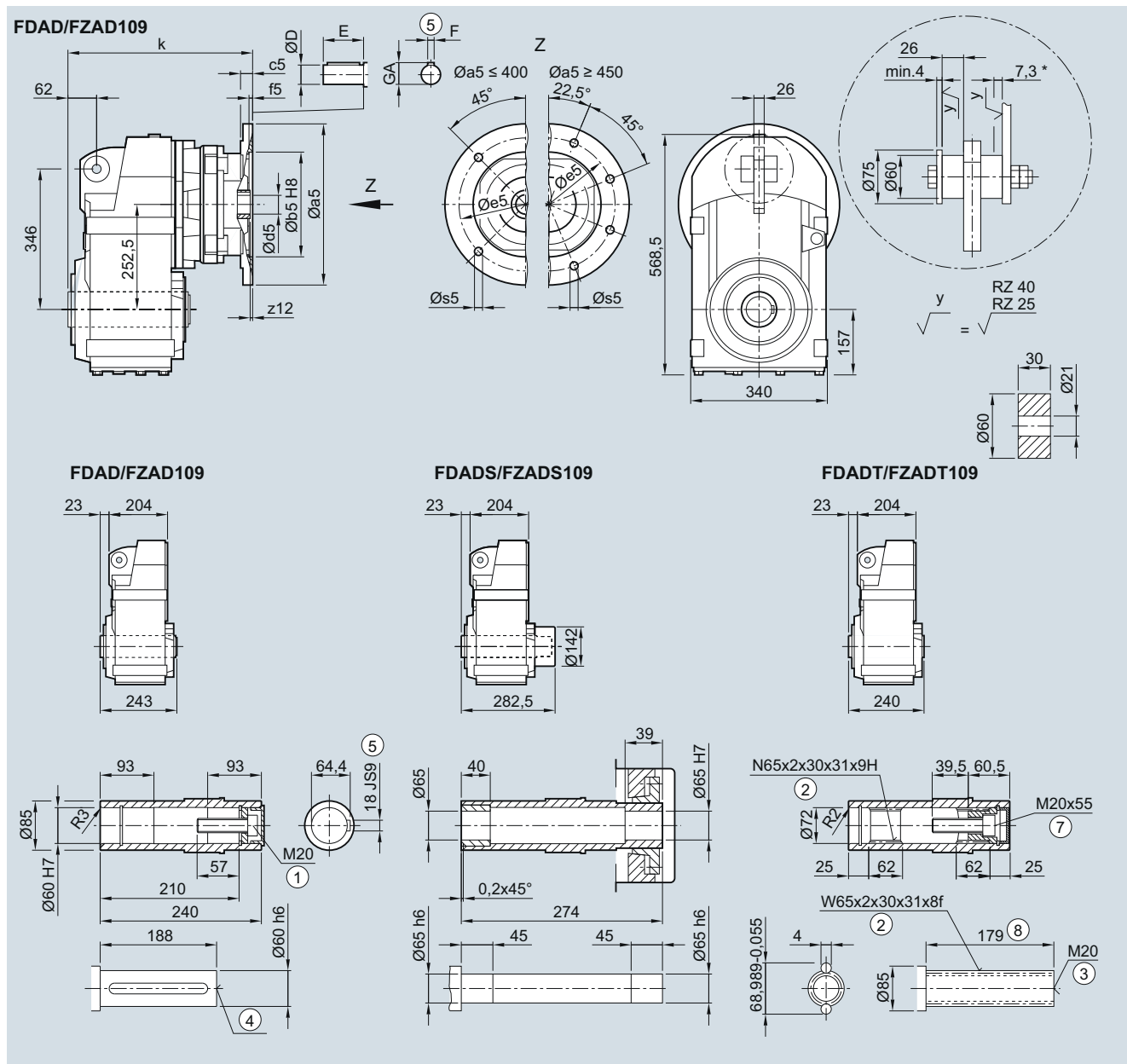

Adapter	a5	b5	c5	f5	e5	s5	z12	d5/D	E	F	GA	k
90	200	130	15	4.5	165	M10	4.0	24	50	8	27.0	297.0
100	250	180	14	5.0	215	M12x21	7.5	28	60	8	31.0	345.5
112	250	180	14	5.0	215	M12x21	7.5	28	60	8	31.0	345.5
132	300	230	12	5.0	265	M12x20	3.0	38	80	10	41.0	363.0
160	350	250	15	6.0	300	M16x25	3.0	42	110	12	45.0	393.0
180	350	250	15	6.0	300	M16x25	3.0	48	110	14	51.5	393.0
200	400	300	20	6.0	350	M16x29	7.0	55	110	16	59.0	433.5
225	450	350	20	6	400	M16x29	7.0	60	140	18	64.0	440.0

① ISO 4014 ② DIN 5480 ③ DIN 332-D ④ DIN 332 ⑤ Feather key/keyway DIN 6885 ⑦ ISO 4762 ⑧ Without locating shoulder +1 mm

* Spring compression at max. torque

FD.Z./FZ.Z.109 gearbox in a housing flange design

FDZ030K4, FAZ030K4, FASZ030K4, FAZT030K4

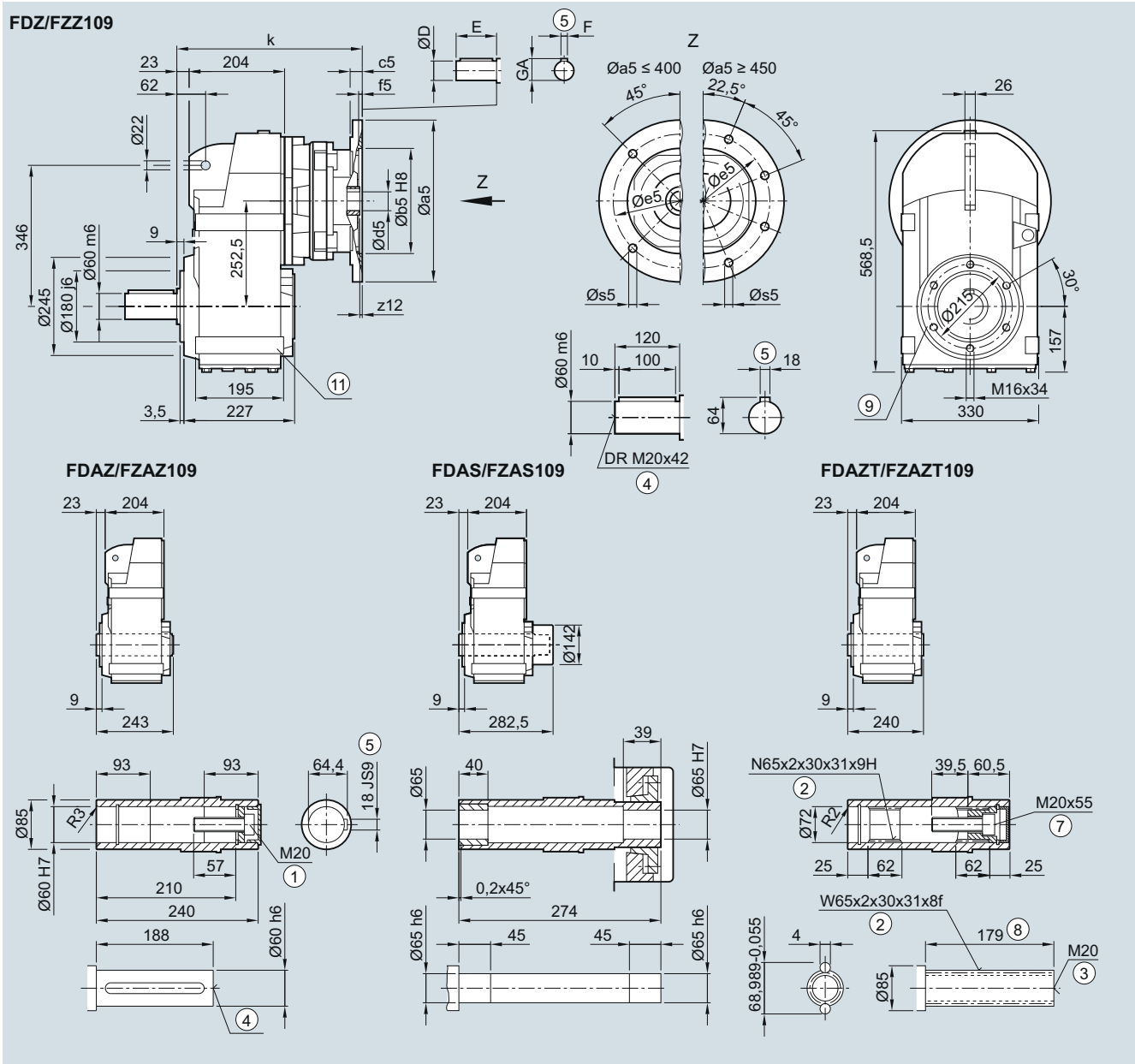

Adapter	a5	b5	c5	f5	e5	s5	z12	d5/D	E	F	GA	k
90	200	130	15	4.5	165	M10	4.0	24	50	8	27.0	297.0
100	250	180	14	5.0	215	M12x21	7.5	28	60	8	31.0	345.5
112	250	180	14	5.0	215	M12x21	7.5	28	60	8	31.0	345.5
132	300	230	12	5.0	265	M12x20	3.0	38	80	10	41.0	363.0
160	350	250	15	6.0	300	M16x25	3.0	42	110	12	45.0	393.0
180	350	250	15	6.0	300	M16x25	3.0	48	110	14	51.5	393.0
200	400	300	20	6.0	350	M16x29	7.0	55	110	16	59.0	433.5
225	450	350	20	6	400	M16x29	7.0	60	140	18	64.0	440.0

① ISO 4014

② DIN 5480

③ DIN 332-D

④ DIN 332

⑤ Feather key/keyway DIN 6885

⑦ ISO 4762

⑧ Without locating shoulder +1 mm

⑨ For pin holes, see 4/131

⑩ Use bores only for foot-mounted design

FD../FZ..109 gearbox in a foot-mounted design

F030K4, FA030K4, FAS030K4, FAT030K4

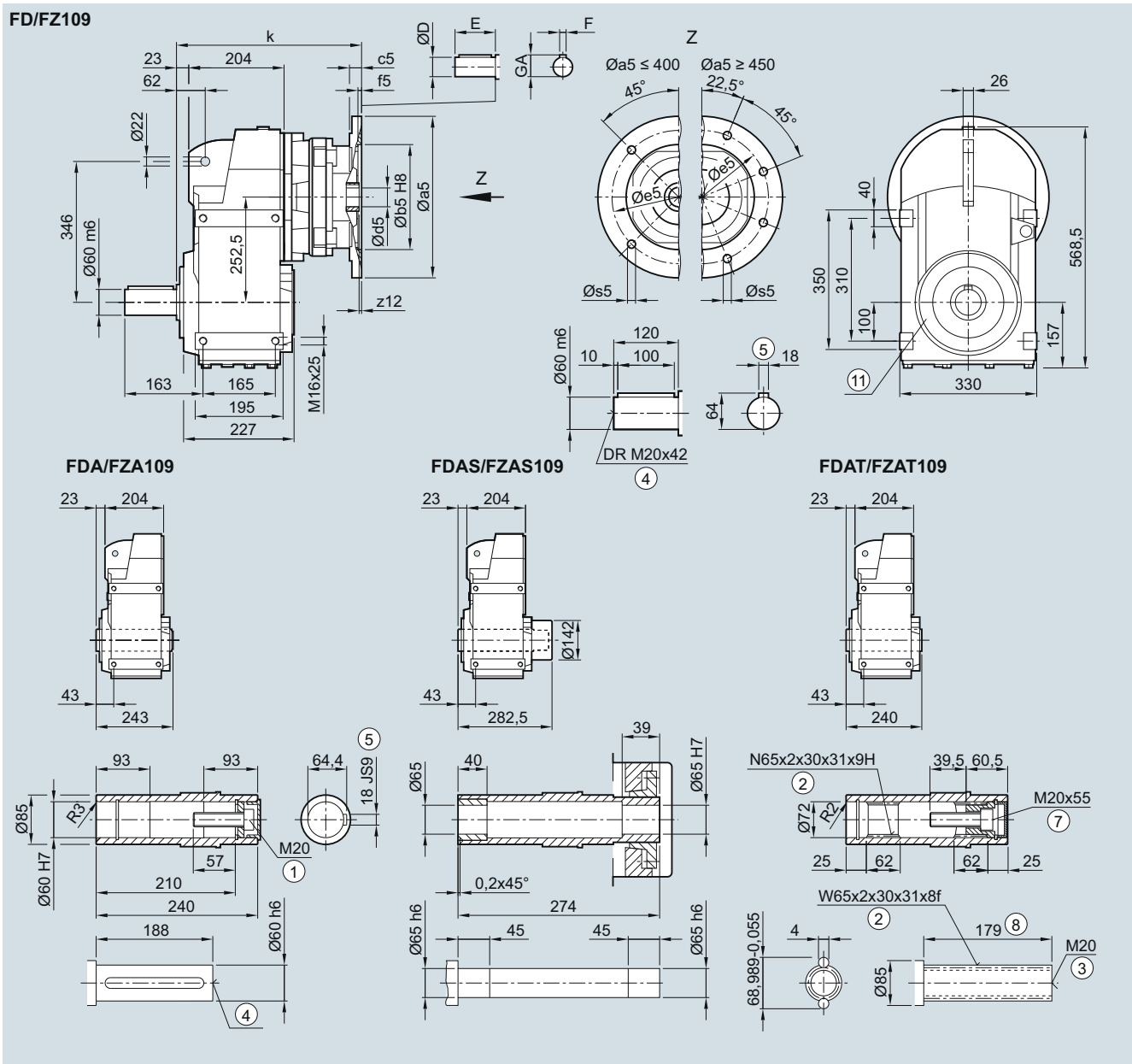

Adapter	a5	b5	c5	f5	e5	s5	z12	d5/D	E	F	GA	k
90	200	130	15	4.5	165	M10	4.0	24	50	8	27.0	297.0
100	250	180	14	5.0	215	M12x21	7.5	28	60	8	31.0	345.5
112	250	180	14	5.0	215	M12x21	7.5	28	60	8	31.0	345.5
132	300	230	12	5.0	265	M12x20	3.0	38	80	10	41.0	363.0
160	350	250	15	6.0	300	M16x25	3.0	42	110	12	45.0	393.0
180	350	250	15	6.0	300	M16x25	3.0	48	110	14	51.5	393.0
200	400	300	20	6.0	350	M16x29	7.0	55	110	16	59.0	433.5
225	450	350	20	6	400	M16x29	7.0	60	140	18	64.0	440.0

① ISO 4014

② DIN 5480

③ DIN 332-D

④ DIN 332

⑤ Feather key/keyway DIN 6885

⑦ ISO 4762

⑧ Without locating shoulder +1 mm

⑨ Use bores only for housing flange design

SIMOGEAR Gearboxes

Parallel shaft gearbox with adapter K4

Dimensions

FDAD./FZAD.129 gearbox in a shaft-mounted design

FAD030K4, FADS030K4, FADT030K4

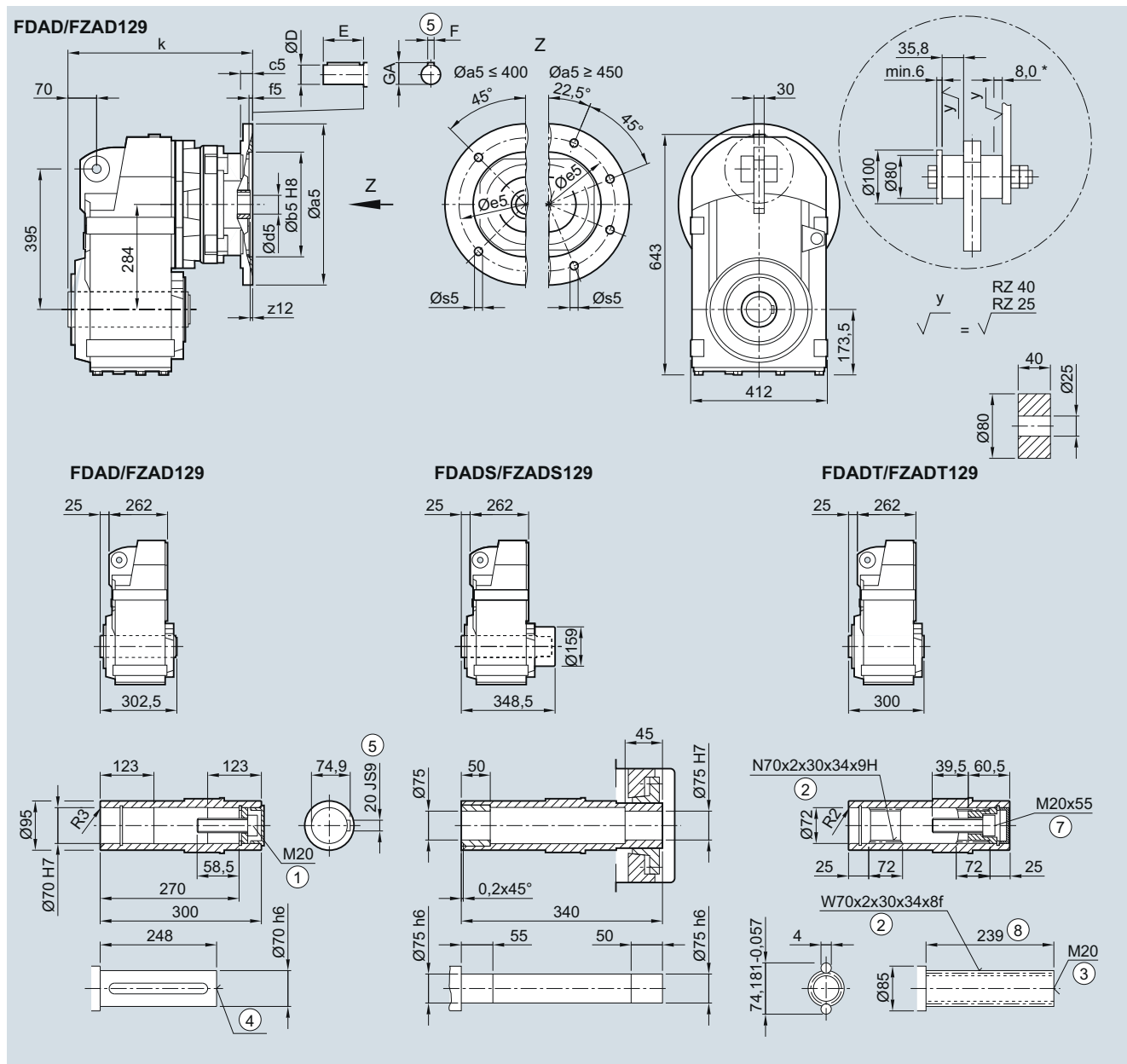

Adapter	a5	b5	c5	f5	e5	s5	z12	d5/D	E	F	GA	k
90	200	130	15	4.5	165	M10	4.0	24	50	8	27.0	350.0
100	250	180	14	5.0	215	M12x21	7.5	28	60	8	31.0	396.5
112	250	180	14	5.0	215	M12x21	7.5	28	60	8	31.0	396.5
132	300	230	12	5.0	265	M12x20	3.0	38	80	10	41.0	412.0
160	350	250	15	6.0	300	M16x25	3.0	42	110	12	45.0	442.0
180	350	250	15	6.0	300	M16x25	3.0	48	110	14	51.5	442.0
200	400	300	20	6.0	350	M16x29	7.0	55	110	16	59.0	482.5
225	450	350	20	6	400	M16x29	7.0	60	140	18	64.0	495.0
250	550	450	20	6.0	500	M16x29	10.0	65	140	18	69.0	523.5

① ISO 4014 ② DIN 5480 ③ DIN 332-D ④ DIN 332 ⑤ Feather key/keyway DIN 6885 ⑦ ISO 4762 ⑧ Without locating shoulder +1 mm

* Spring compression at max. torque

FD.Z./FZ.Z.129 gearbox in a housing flange design

FZ030K4, FAZ030K4, FAZS030K4, FAZT030K4

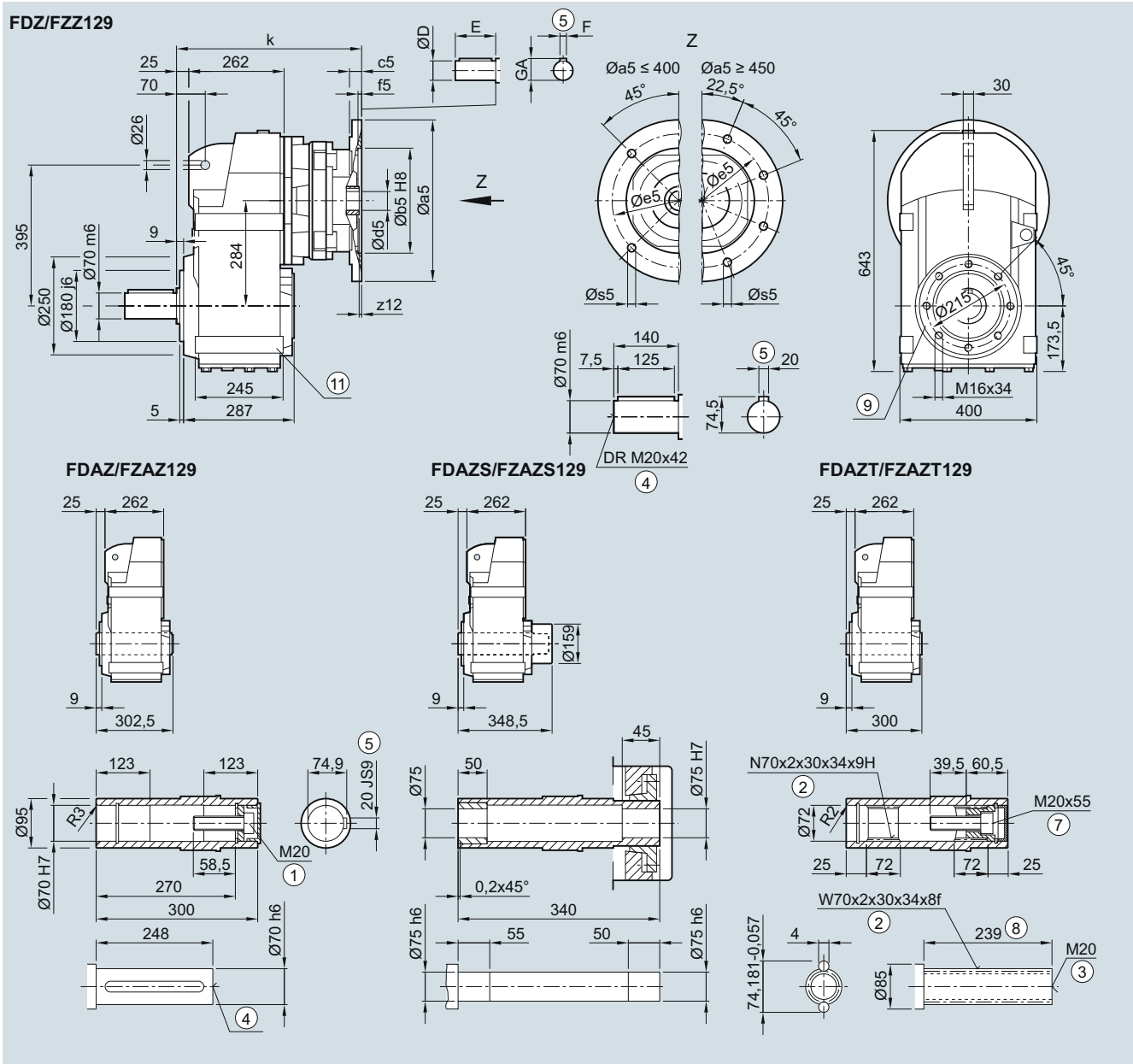

Adapter	a5	b5	c5	f5	e5	s5	z12	d5/D	E	F	GA	k
90	200	130	15	4.5	165	M10	4.0	24	50	8	27.0	350.0
100	250	180	14	5.0	215	M12x21	7.5	28	60	8	31.0	396.5
112	250	180	14	5.0	215	M12x21	7.5	28	60	8	31.0	396.5
132	300	230	12	5.0	265	M12x20	3.0	38	80	10	41.0	412.0
160	350	250	15	6.0	300	M16x25	3.0	42	110	12	45.0	442.0
180	350	250	15	6.0	300	M16x25	3.0	48	110	14	51.5	442.0
200	400	300	20	6.0	350	M16x29	7.0	55	110	16	59.0	482.5
225	450	350	20	6	400	M16x29	7.0	60	140	18	64.0	495.0
250	550	450	20	6.0	500	M16x29	10.0	65	140	18	69.0	523.5

① ISO 4014 ② DIN 5480 ③ DIN 332-D ④ DIN 332 ⑤ Feather key/keyway DIN 6885
 ⑦ ISO 4762 ⑥ Without locating shoulder +1 mm ⑨ For pin holes, see 4/131 ⑩ Use bores only for foot-mounted design

SIMOGEAR Gearboxes

Parallel shaft gearbox with adapter K4

Dimensions

FD.F/FZ.F129 gearbox in a flange-mounted design

FF030K4, FAF030K4, FAFS030K4, FAFT030K4

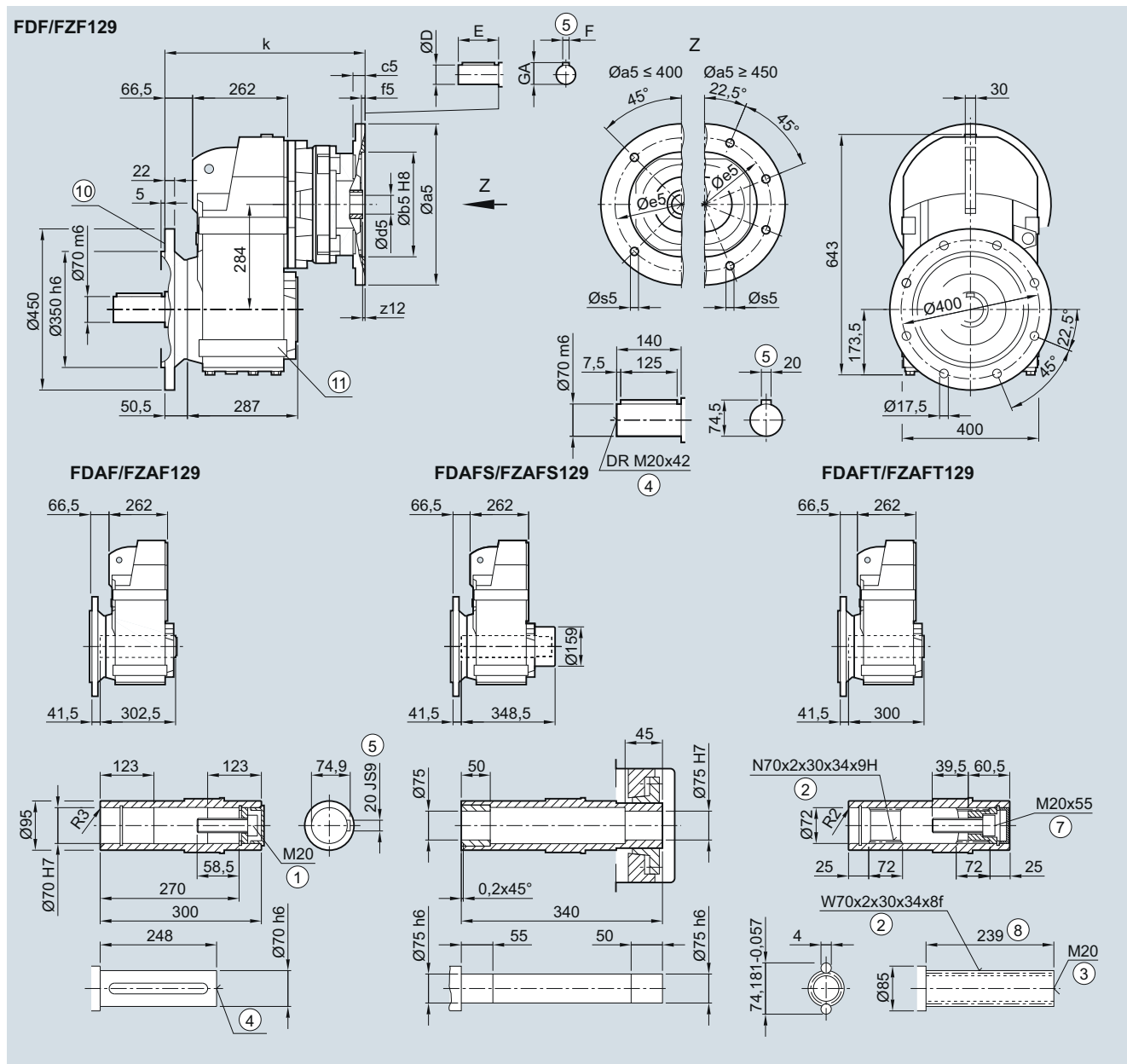

Adapter	a5	b5	c5	f5	e5	s5	z12	d5/D	E	F	GA	k
90	200	130	15	4.5	165	M10	4.0	24	50	8	27.0	391.5
100	250	180	14	5.0	215	M12x21	7.5	28	60	8	31.0	438.0
112	250	180	14	5.0	215	M12x21	7.5	28	60	8	31.0	438.0
132	300	230	12	5.0	265	M12x20	3.0	38	80	10	41.0	453.5
160	350	250	15	6.0	300	M16x25	3.0	42	110	12	45.0	483.5
180	350	250	15	6.0	300	M16x25	3.0	48	110	14	51.5	483.5
200	400	300	20	6.0	350	M16x29	7.0	55	110	16	59.0	524.0
225	450	350	20	6	400	M16x29	7.0	60	140	18	64.0	536.5
250	550	450	20	6.0	500	M16x29	10.0	65	140	18	69.0	565.0

① ISO 4014 ② DIN 5480 ③ DIN 332-D ④ DIN 332 ⑤ Feather key/keyway DIN 6885
 ⑦ ISO 4762 ⑥ Without locating shoulder +1 mm ⑩ For inner contour, see page 4/129 ⑧ Use bores only for foot-mounted design

FD../FZ..129 gearbox in a foot-mounted design

F030K4, FA030K4, FAS030K4, FAT030K4

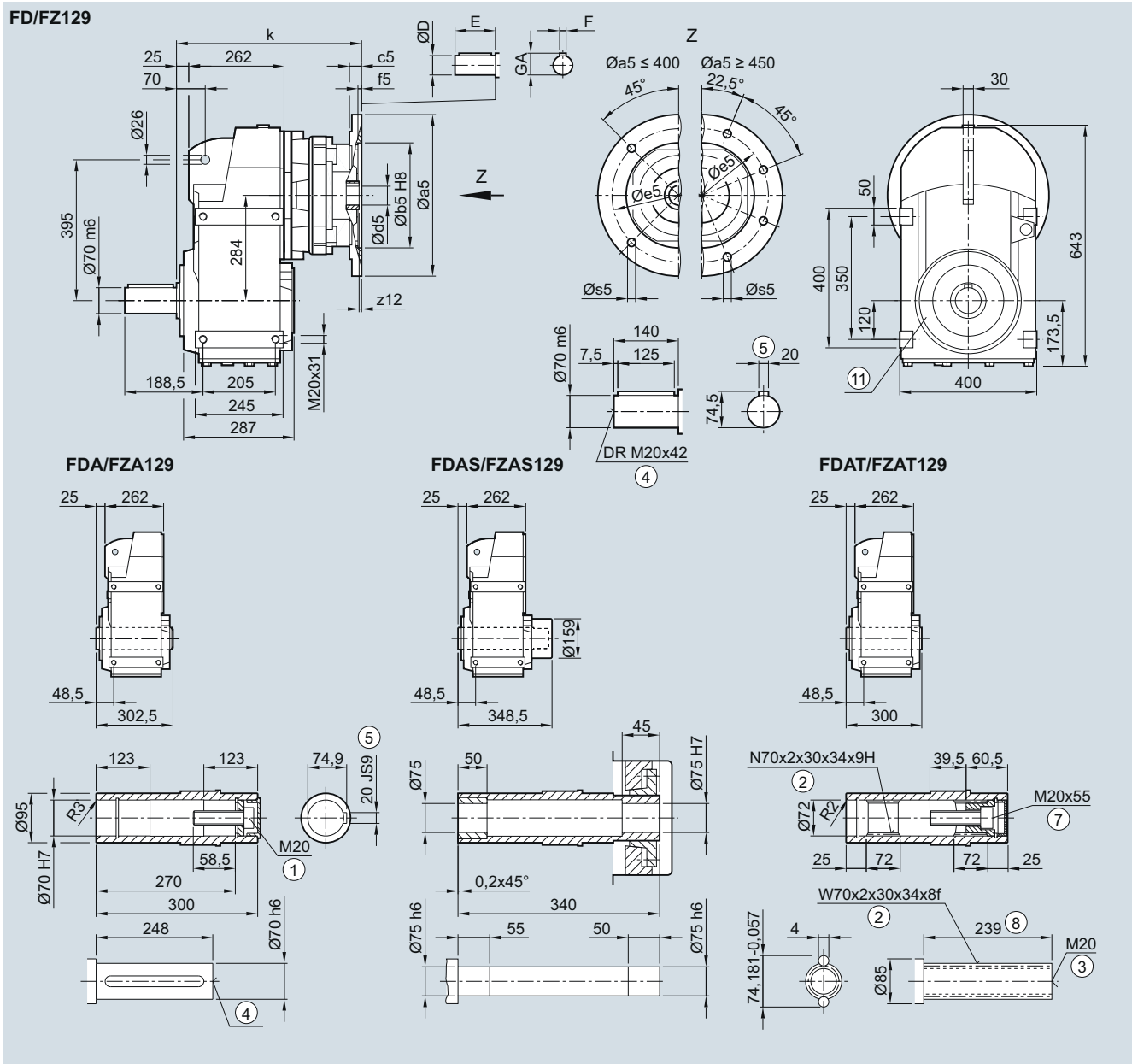

Adapter	a5	b5	c5	f5	e5	s5	z12	d5/D	E	F	GA	k
90	200	130	15	4.5	165	M10	4.0	24	50	8	27.0	350.0
100	250	180	14	5.0	215	M12x21	7.5	28	60	8	31.0	396.5
112	250	180	14	5.0	215	M12x21	7.5	28	60	8	31.0	396.5
132	300	230	12	5.0	265	M12x20	3.0	38	80	10	41.0	412.0
160	350	250	15	6.0	300	M16x25	3.0	42	110	12	45.0	442.0
180	350	250	15	6.0	300	M16x25	3.0	48	110	14	51.5	442.0
200	400	300	20	6.0	350	M16x29	7.0	55	110	16	59.0	482.5
225	450	350	20	6.0	400	M16x29	7.0	60	140	18	64.0	495.0
250	550	450	20	6.0	500	M16x29	10.0	65	140	18	69.0	523.5

- ① ISO 4014 ② DIN 5480 ③ DIN 332-D ④ DIN 332
- ⑤ Feather key/keyway DIN 6885 ⑦ ISO 4762 ⑧ Without locating shoulder +1 mm ⑩ Use bores only for housing flange design



SIMOGEAR Gearboxes

Parallel shaft gearbox with adapter K4

Dimensions

FDAD./FZAD.149 gearbox in a shaft-mounted design

FAD030K4, FADS030K4, FADT030K4

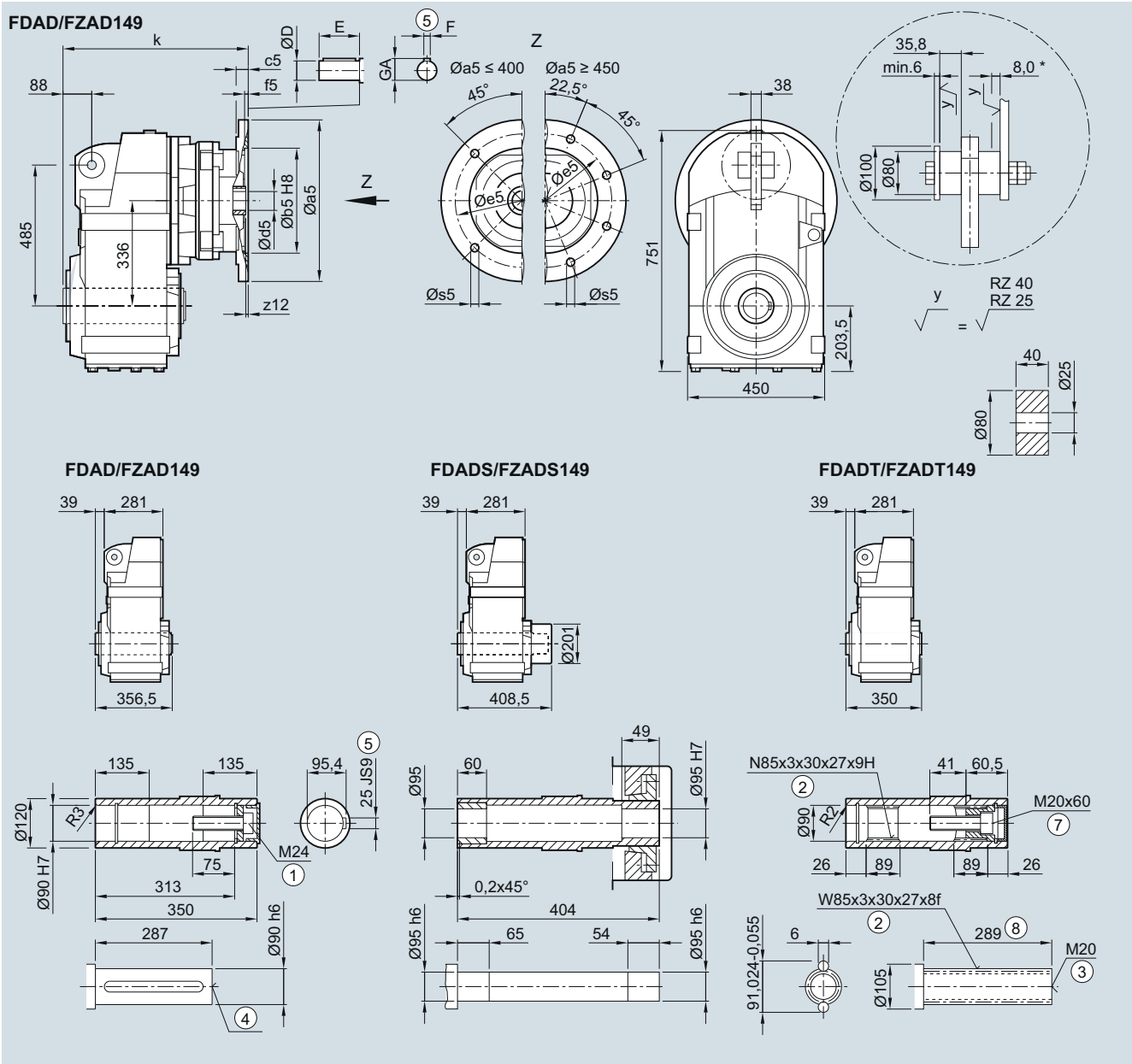

Adapter	a5	b5	c5	f5	e5	s5	z12	d5/D	E	F	GA	k
100	250	180	14	5.0	215	M12x21	7.5	28	60	8	31.0	428.5
112	250	180	14	5.0	215	M12x21	7.5	28	60	8	31.0	428.5
132	300	230	12	5.0	265	M12x20	3.0	38	80	10	41.0	439.0
160	350	250	15	6.0	300	M16x25	3.0	42	110	12	45.0	469.0
180	350	250	15	6.0	300	M16x25	3.0	48	110	14	51.5	469.0
200	400	300	20	6.0	350	M16x29	7.0	55	110	16	59.0	509.5
225	450	350	20	6	400	M16x29	7.0	60	140	18	64.0	516.0
250	550	450	20	6.0	500	M16x29	10.0	65	140	18	69.0	550.5

① ISO 4014 ② DIN 5480 ③ DIN 332-D ④ DIN 332 ⑤ Feather key/keyway DIN 6885 ⑦ ISO 4762 ⑥ Without locating shoulder +1 mm

* Spring compression at max. torque

FD.Z./FZ.Z.149 gearbox in a housing flange design

FZ030K4, FAZ030K4, FZS030K4, FAZT030K4

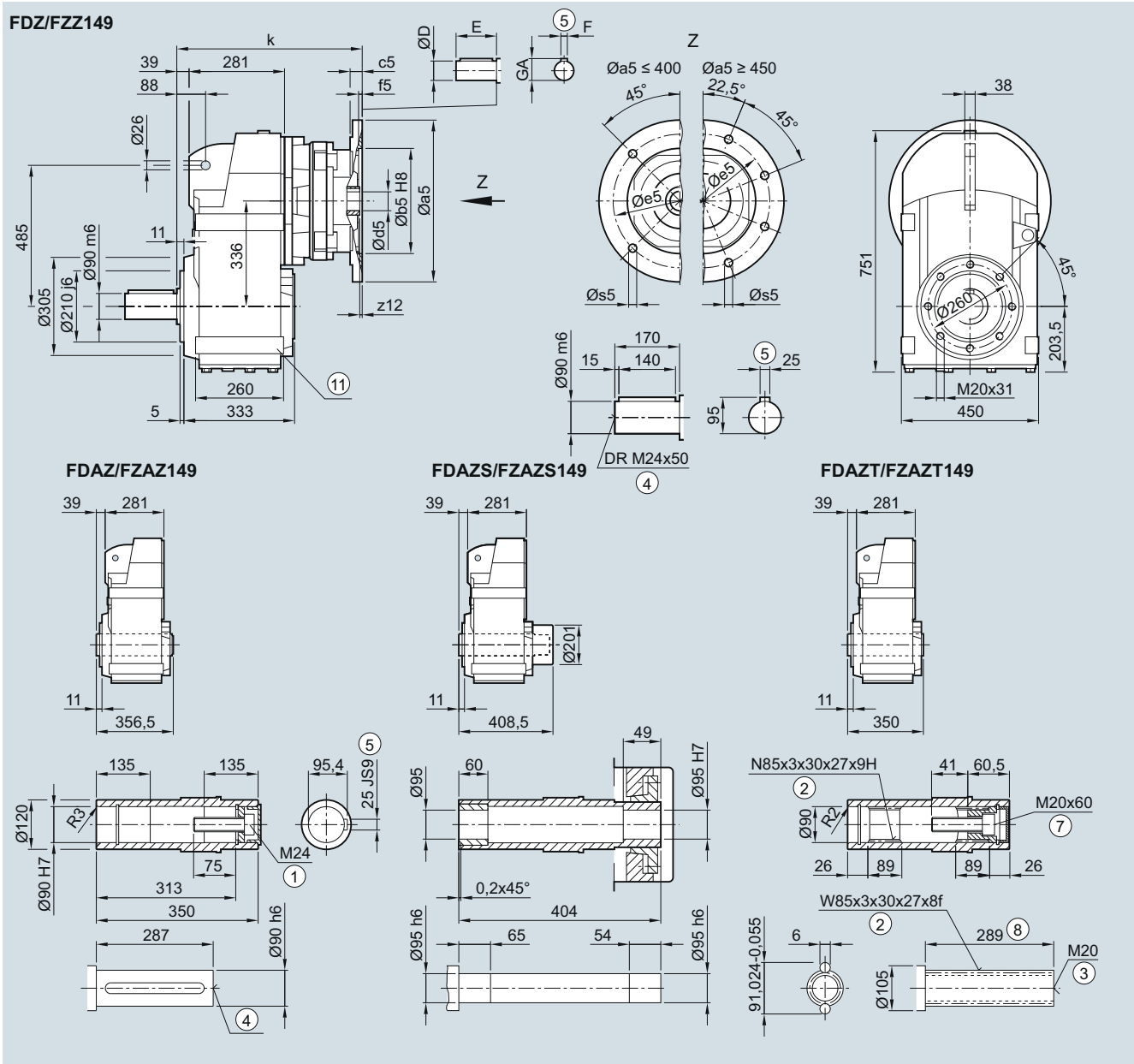

4

Adapter	a5	b5	c5	f5	e5	s5	z12	d5/D	E	F	GA	k
100	250	180	14	5.0	215	M12x21	7.5	28	60	8	31.0	428.5
112	250	180	14	5.0	215	M12x21	7.5	28	60	8	31.0	428.5
132	300	230	12	5.0	265	M12x20	3.0	38	80	10	41.0	439.0
160	350	250	15	6.0	300	M16x25	3.0	42	110	12	45.0	469.0
180	350	250	15	6.0	300	M16x25	3.0	48	110	14	51.5	469.0
200	400	300	20	6.0	350	M16x29	7.0	55	110	16	59.0	509.5
225	450	350	20	6	400	M16x29	7.0	60	140	18	64.0	516.0
250	550	450	20	6.0	500	M16x29	10.0	65	140	18	69.0	550.5

① ISO 4014

② DIN 5480

③ DIN 332-D

④ DIN 332

⑤ Feather key/keyway DIN 6885

⑦ ISO 4762

⑧ Without locating shoulder +1 mm

⑩ Use bores only for foot-mounted design

FD../FZ..149 gearbox in a foot-mounted design

F030K4, FA030K4, FAS030K4, FAT030K4

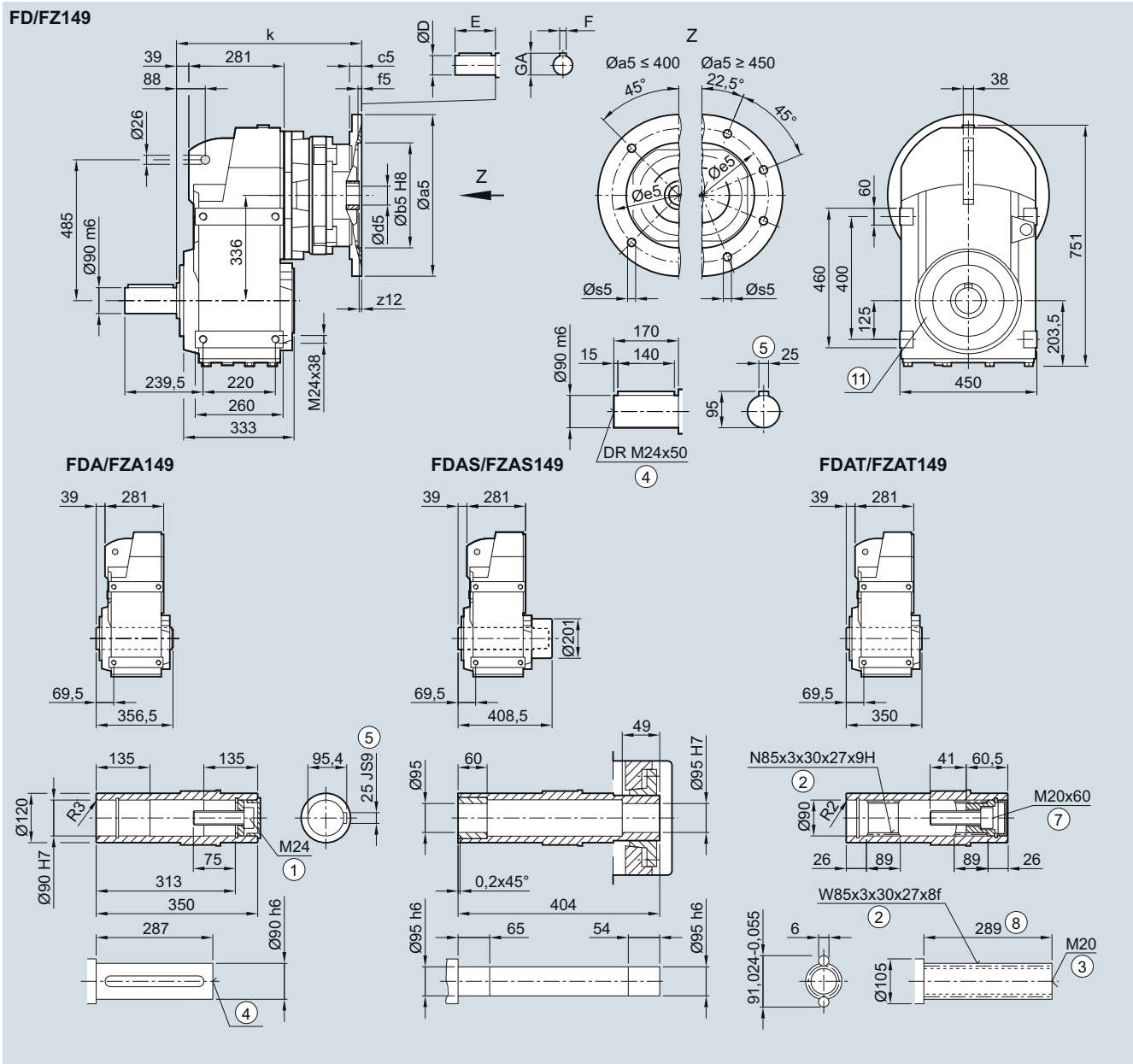

Adapter	a5	b5	c5	f5	e5	s5	z12	d5/D	E	F	GA	k
100	250	180	14	5.0	215	M12x21	7.5	28	60	8	31.0	428.5
112	250	180	14	5.0	215	M12x21	7.5	28	60	8	31.0	428.5
132	300	230	12	5.0	265	M12x20	3.0	38	80	10	41.0	439.0
160	350	250	15	6.0	300	M16x25	3.0	42	110	12	45.0	469.0
180	350	250	15	6.0	300	M16x25	3.0	48	110	14	51.5	469.0
200	400	300	20	6.0	350	M16x29	7.0	55	110	16	59.0	509.5
225	450	350	20	6	400	M16x29	7.0	60	140	18	64.0	516.0
250	550	450	20	6.0	500	M16x29	10.0	65	140	18	69.0	550.5

- ① ISO 4014 ② DIN 5480 ③ DIN 332-D ④ DIN 332
- ⑤ Feather key/keyway DIN 6885 ⑦ ISO 4762 ⑧ Without locating shoulder +1 mm ⑩ Use bores only for housing flange design

SIMOGEAR Gearboxes

Parallel shaft gearbox with adapter K4

Dimensions

FDAD./FZAD.169 gearbox in a shaft-mounted design

FAD030K4, FADS030K4, FADT030K4

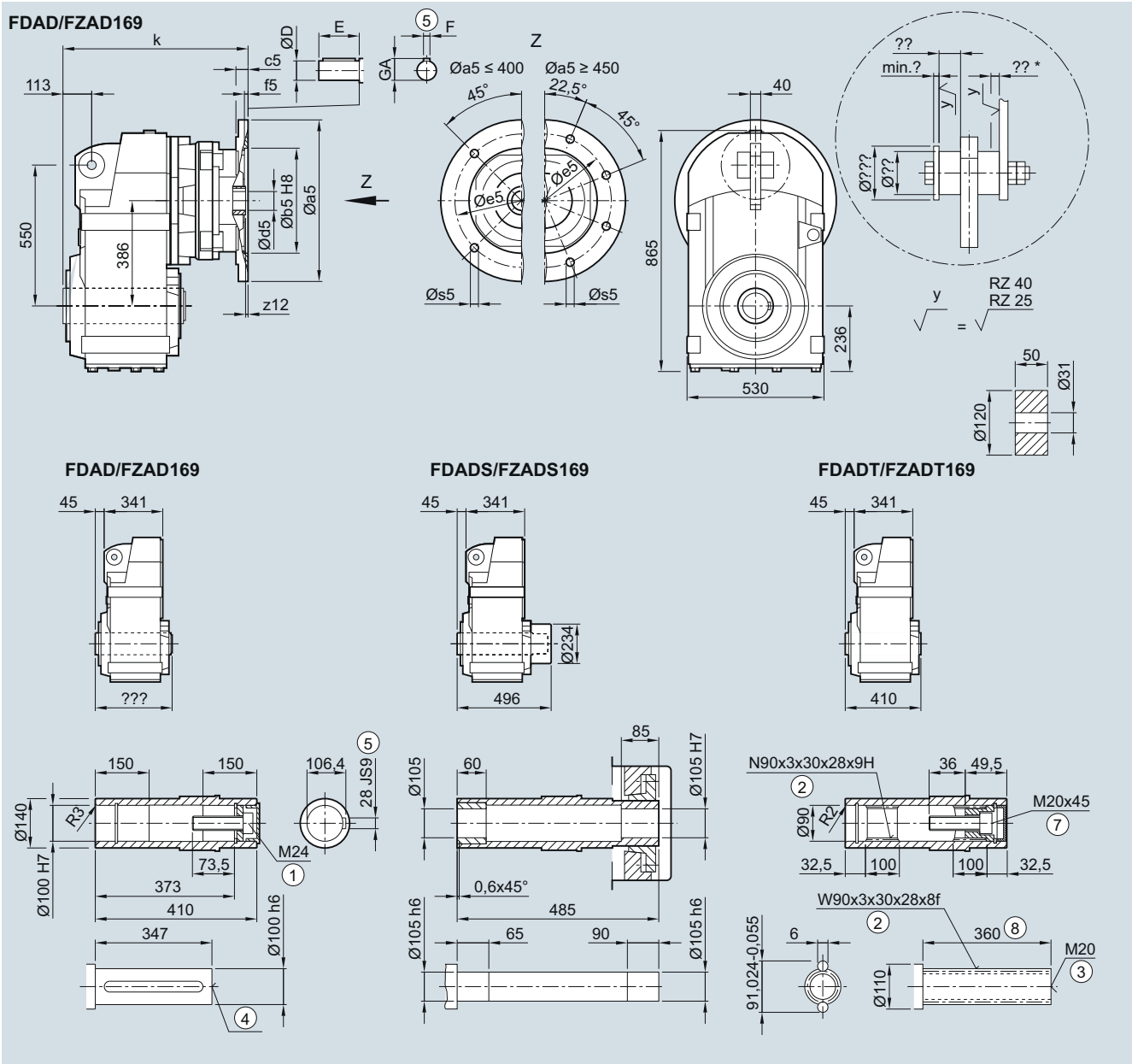

Adapter	a5	b5	c5	f5	e5	s5	z12	d5/D	E	F	GA	k
112	250	180	14	5.0	215	M12x21	7.5	28	60	8	31.0	481.5
132	300	230	12	5.0	265	M12x20	3.0	38	80	10	41.0	491.5
160	350	250	15	6.0	300	M16x25	3.0	42	110	12	45.0	521.5
180	350	250	15	6.0	300	M16x25	3.0	48	110	14	51.5	521.5
200	400	300	20	6.0	350	M16x29	7.0	55	110	16	59.0	561.5
225	450	350	20	6	400	M16x29	7.0	60	140	18	64.0	567.0
250	550	450	20	6.0	500	M16x29	10.0	65	140	18	69.0	597.5

① ISO 4014 ② DIN 5480 ③ DIN 332-D ④ DIN 332 ⑤ Feather key/keyway DIN 6885 ⑦ ISO 4762 ⑥ Without locating shoulder +1 mm

* Spring compression at max. torque

FD.Z./FZ.Z.169 gearbox in a housing flange design

FZ030K4, FAZ030K4, FAZS030K4, FAZT030K4

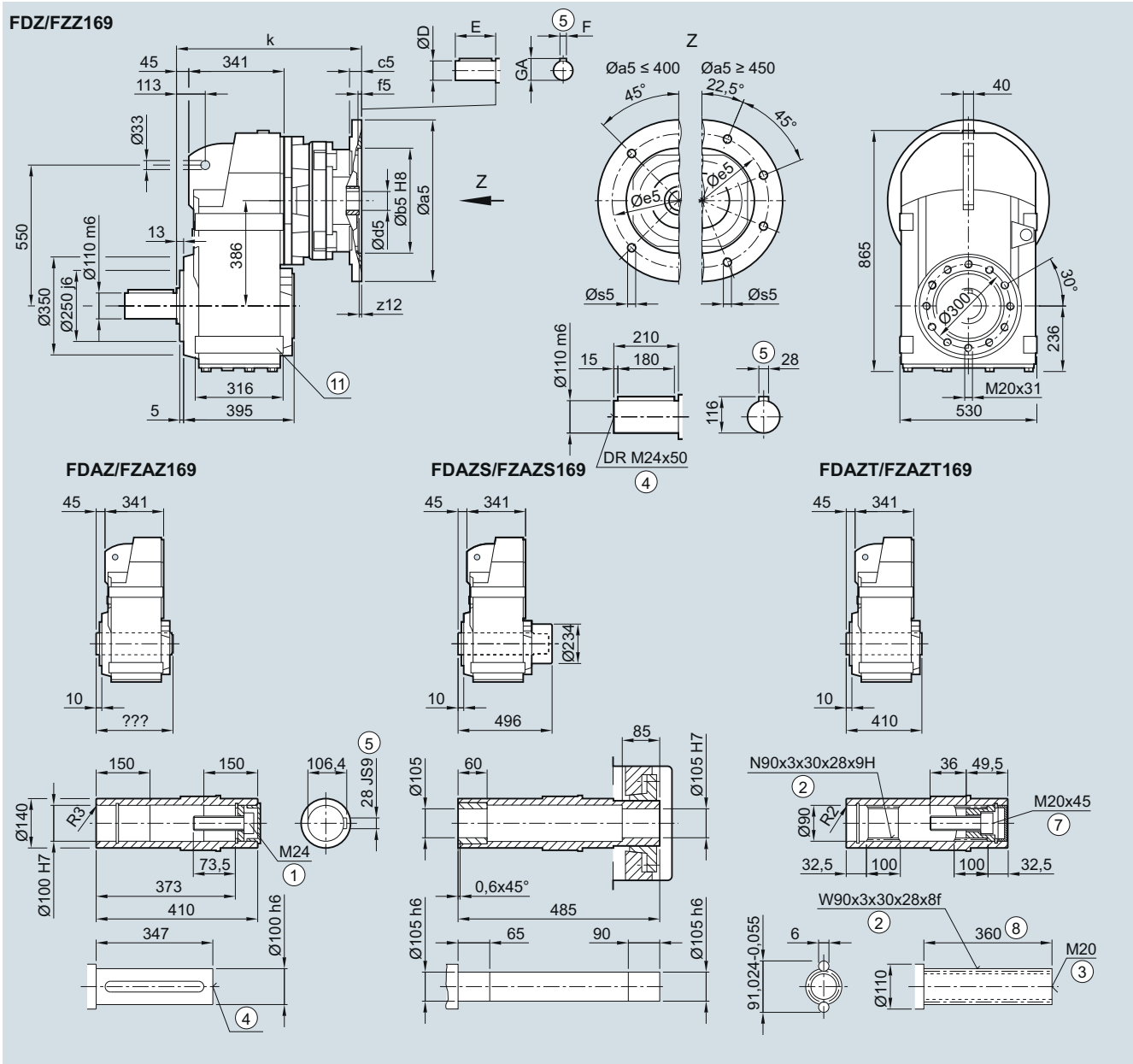

4

Adapter	a5	b5	c5	f5	e5	s5	z12	d5/D	E	F	GA	k
112	250	180	14	5.0	215	M12x21	7.5	28	60	8	31.0	481.5
132	300	230	12	5.0	265	M12x20	3.0	38	80	10	41.0	491.5
160	350	250	15	6.0	300	M16x25	3.0	42	110	12	45.0	521.5
180	350	250	15	6.0	300	M16x25	3.0	48	110	14	51.5	521.5
200	400	300	20	6.0	350	M16x29	7.0	55	110	16	59.0	561.5
225	450	350	20	6	400	M16x29	7.0	60	140	18	64.0	567.0
250	550	450	20	6.0	500	M16x29	10.0	65	140	18	69.0	597.5

① ISO 4014 ② DIN 5480 ③ DIN 332-D ④ DIN 332
 ⑤ Feather key/keyway DIN 6885 ⑦ ISO 4762 ⑧ Without locating shoulder +1 mm ⑩ Use bores only for foot-mounted design

SIMOGEAR Gearboxes

Parallel shaft gearbox in a flange-mounted design

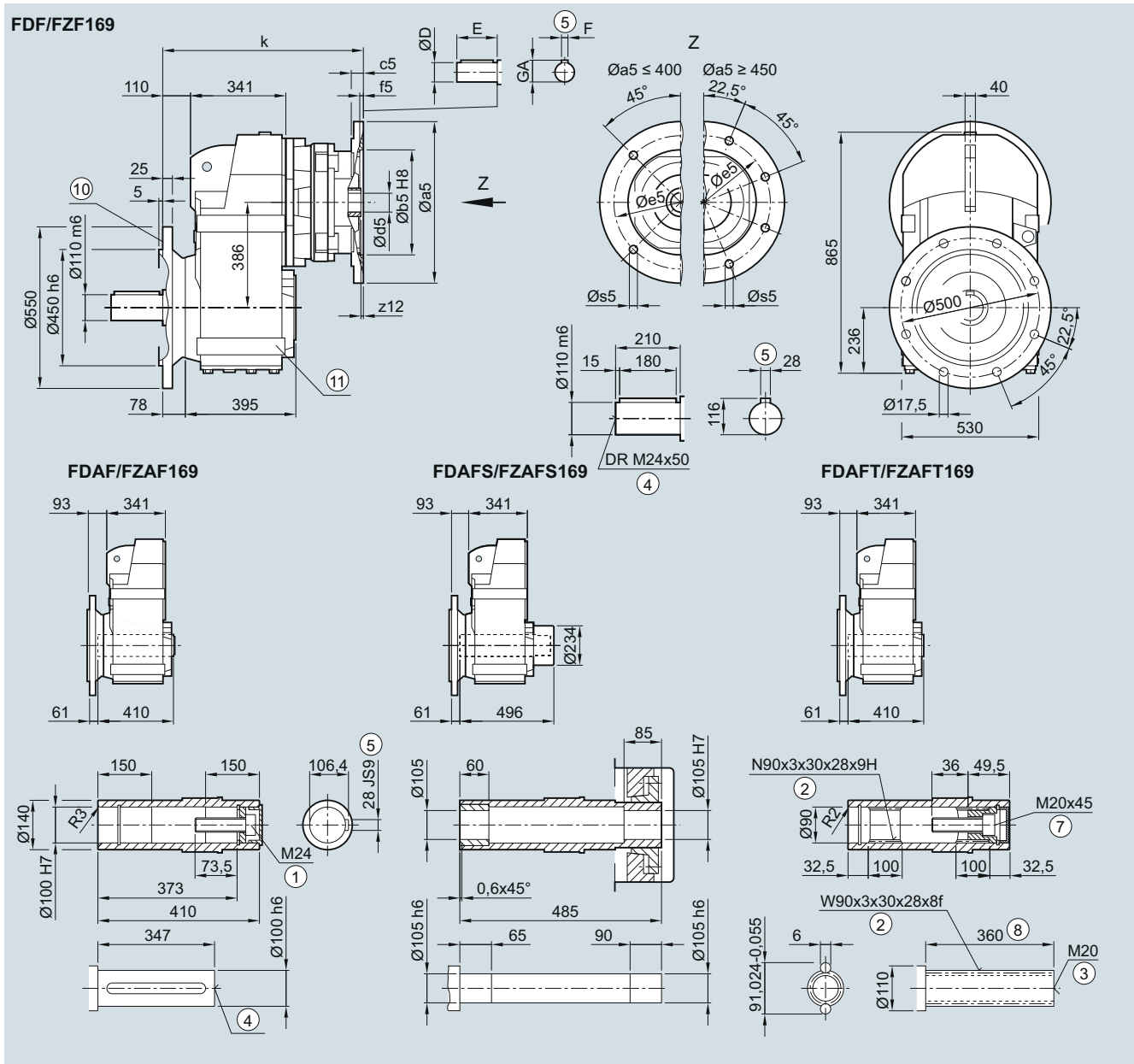
Dimensions**FD.F./FZ.F.169 gearbox in a flange-mounted design****FF030K4, FAF030K4, FAFS030K4, FAFT030K4**

Adapter	a5	b5	c5	f5	e5	s5	z12	d5/D	E	F	GA	k
112	250	180	14	5.0	215	M12x21	7.5	28	60	8	31.0	546.5
132	300	230	12	5.0	265	M12x20	3.0	38	80	10	41.0	556.5
160	350	250	15	6.0	300	M16x25	3.0	42	110	12	45.0	586.5
180	350	250	15	6.0	300	M16x25	3.0	48	110	14	51.5	586.5
200	400	300	20	6.0	350	M16x29	7.0	55	110	16	59.0	626.5
225	450	350	20	6	400	M16x29	7.0	60	140	18	64.0	632.0
250	550	450	20	6.0	500	M16x29	10.0	65	140	18	69.0	662.5

① ISO 4014

② DIN 5480

③ DIN 332-D

④ DIN 332

⑤ Feather key/keyway DIN 6885

⑦ ISO 4762

⑥ Without locating shoulder +1 mm

⑩ For inner contour, see page 4/129

⑪ Use bores only for foot-mounted design

FD./FZ..169 gearbox in a foot-mounted design

F030K4, FA030K4, FAS030K4, FAT030K4

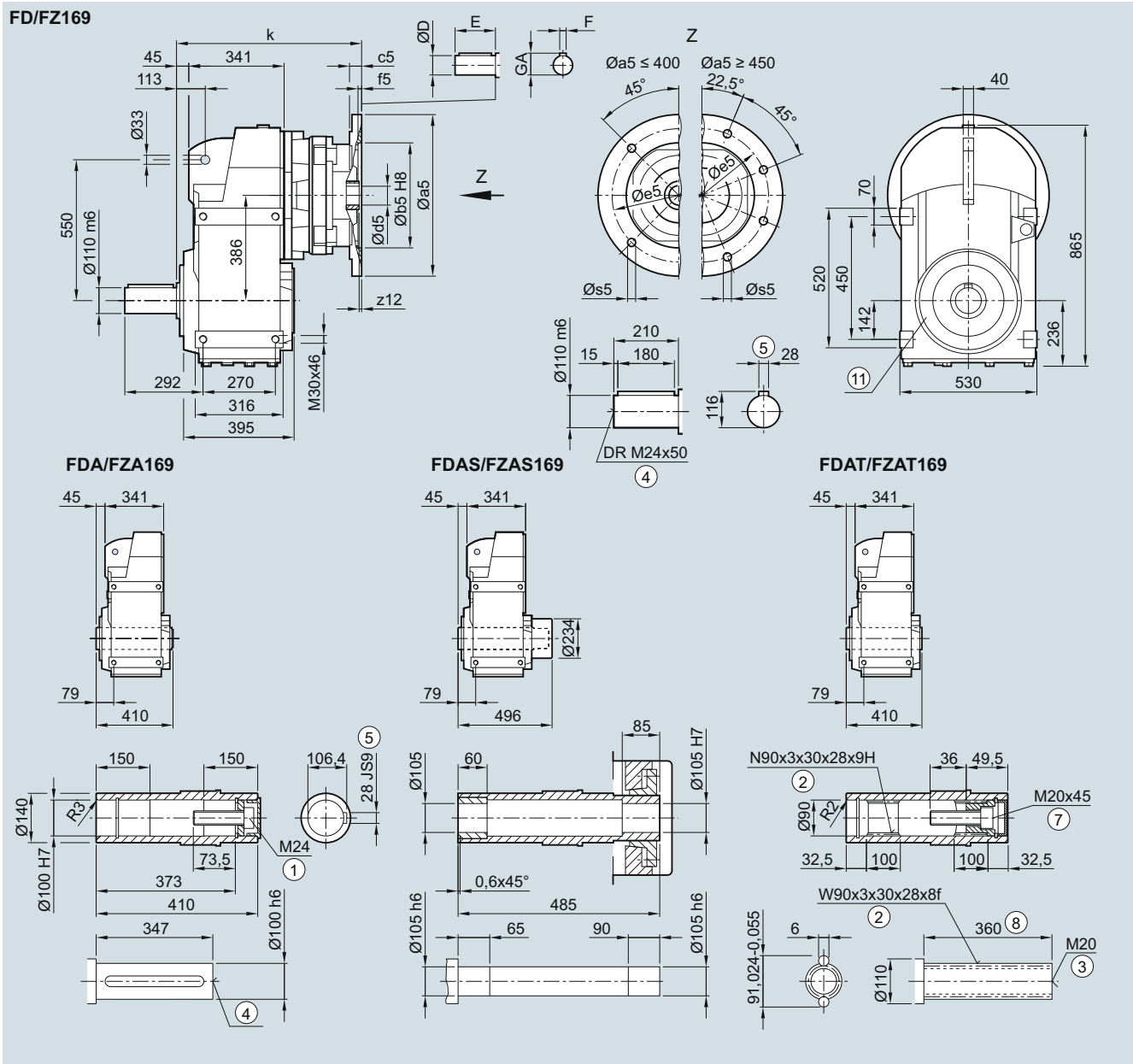

Adapter	a5	b5	c5	f5	e5	s5	z12	d5/D	E	F	GA	k
112	250	180	14	5.0	215	M12x21	7.5	28	60	8	31.0	481.5
132	300	230	12	5.0	265	M12x20	3.0	38	80	10	41.0	491.5
160	350	250	15	6.0	300	M16x25	3.0	42	110	12	45.0	521.5
180	350	250	15	6.0	300	M16x25	3.0	48	110	14	51.5	521.5
200	400	300	20	6.0	350	M16x29	7.0	55	110	16	59.0	561.5
225	450	350	20	6	400	M16x29	7.0	60	140	18	64.0	567.0
250	550	450	20	6.0	500	M16x29	10.0	65	140	18	69.0	597.5

- ① ISO 4014 ② DIN 5480 ③ DIN 332-D ④ DIN 332
- ⑤ Feather key/keyway DIN 6885 ⑦ ISO 4762 ⑧ Without locating shoulder +1 mm ⑨ Use bores only for housing flange design

SIMOGEAR Gearboxes

Parallel shaft gearbox with adapter K4

Dimensions

FDAD./FZAD.189 gearbox in a shaft-mounted design

FAD030K4, FADS030K4, FADT030K4

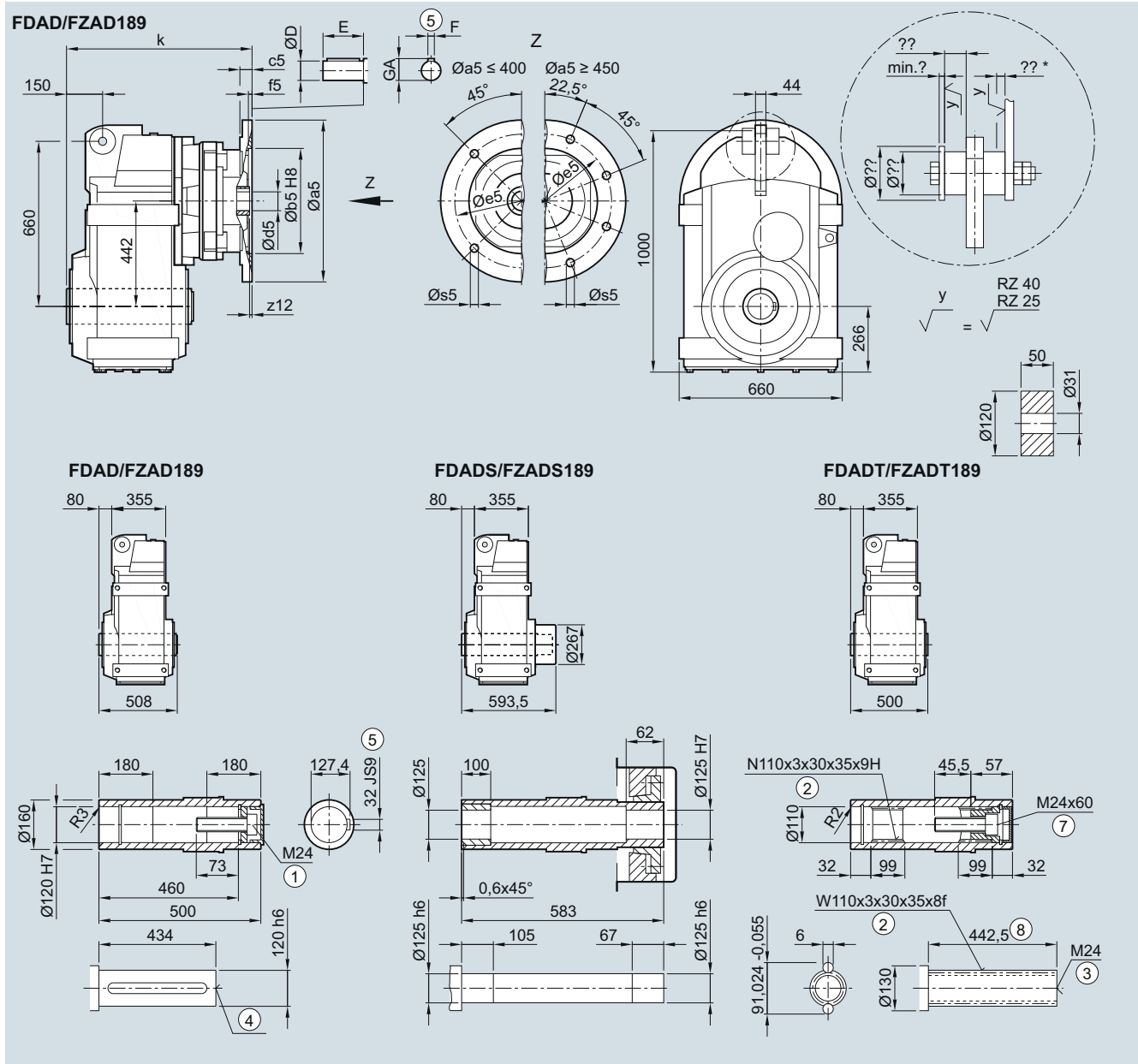

Adapter	a5	b5	c5	f5	e5	s5	z12	d5/D	E	F	GA	k
112	250	180	14	5.0	215	M12x21	7.5	28	60	8	31.0	530.5
132	300	230	12	5.0	265	M12x20	3.0	38	80	10	41.0	540.5
160	350	250	15	6.0	300	M16x25	3.0	42	110	12	45.0	570.5
180	350	250	15	6.0	300	M16x25	3.0	48	110	14	51.5	570.5
200	400	300	20	6.0	350	M16x29	7.0	55	110	16	59.0	610.5
225	450	350	20	6	400	M16x29	7.0	60	140	18	64.0	616.0
250	550	450	20	6.0	500	M16x29	10.0	65	140	18	69.0	646.5

① ISO 4014 ② DIN 5480 ③ DIN 332-D ④ DIN 332 ⑤ Feather key/keyway DIN 6885 ⑦ ISO 4762 ⑧ Without locating shoulder +1 mm

* Spring compression at max. torque

FD.Z/FZ.Z.189 gearbox in a housing flange design

FZ030K4, FAZ030K4, FAZS030K4, FAZT030K4

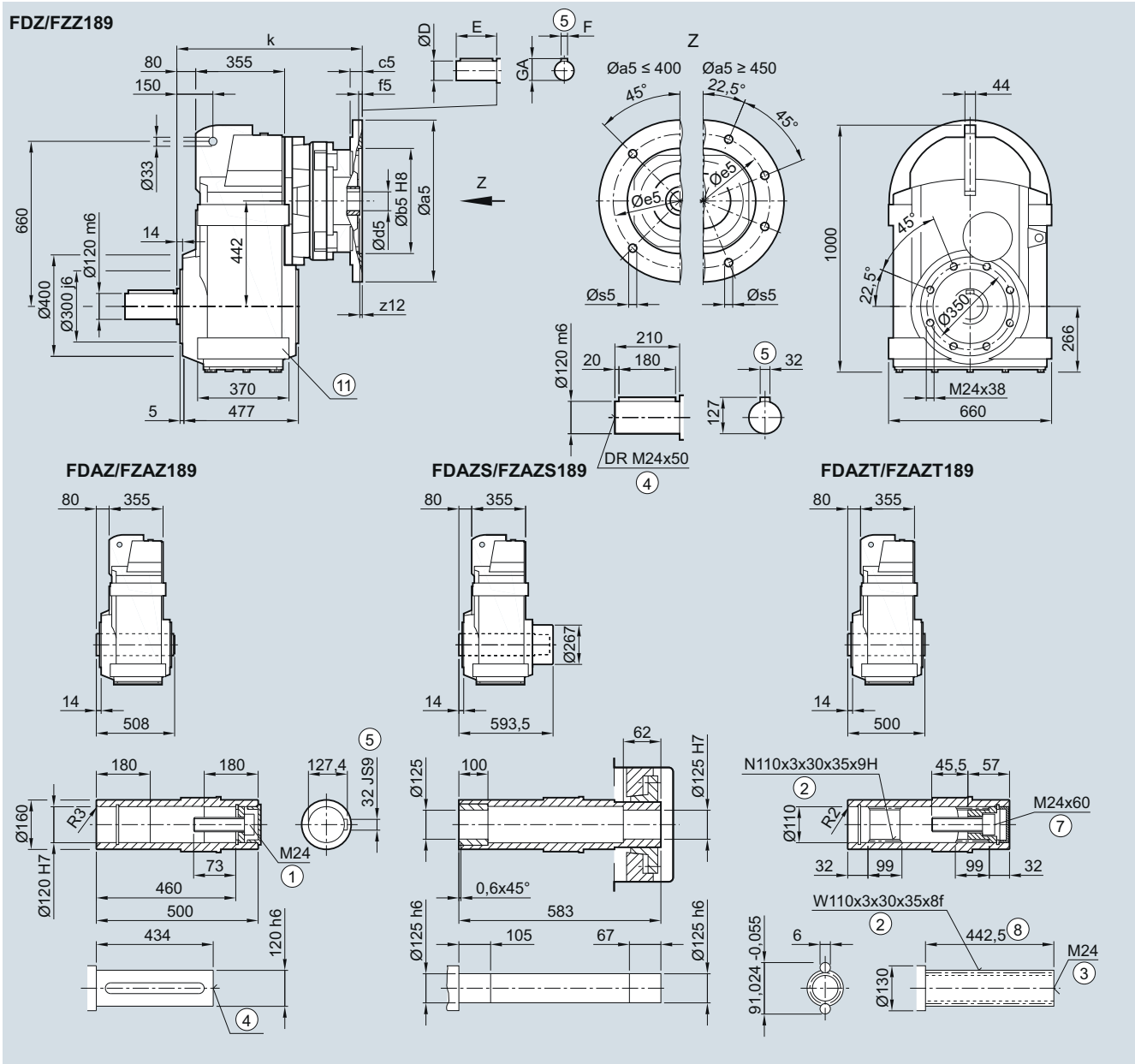

4

Adapter	a5	b5	c5	f5	e5	s5	z12	d5/D	E	F	GA	k
112	250	180	14	5.0	215	M12x21	7.5	28	60	8	31.0	530.5
132	300	230	12	5.0	265	M12x20	3.0	38	80	10	41.0	540.5
160	350	250	15	6.0	300	M16x25	3.0	42	110	12	45.0	570.5
180	350	250	15	6.0	300	M16x25	3.0	48	110	14	51.5	570.5
200	400	300	20	6.0	350	M16x29	7.0	55	110	16	59.0	610.5
225	450	350	20	6	400	M16x29	7.0	60	140	18	64.0	616.0
250	550	450	20	6.0	500	M16x29	10.0	65	140	18	69.0	646.5

- ① ISO 4014 ② DIN 5480 ③ DIN 332-D ④ DIN 332
- ⑤ Feather key/keyway DIN 6885 ⑦ ISO 4762 ⑧ Without locating shoulder +1 mm ⑨ Use bores only for foot-mounted design

SIMOGEAR Gearboxes

Parallel shaft gearbox with adapter K4

Dimensions

FD.F./FZ.F.189 gearbox in a flange-mounted design

FF030K4, FAF030K4, FAFS030K4, FAFT030K4

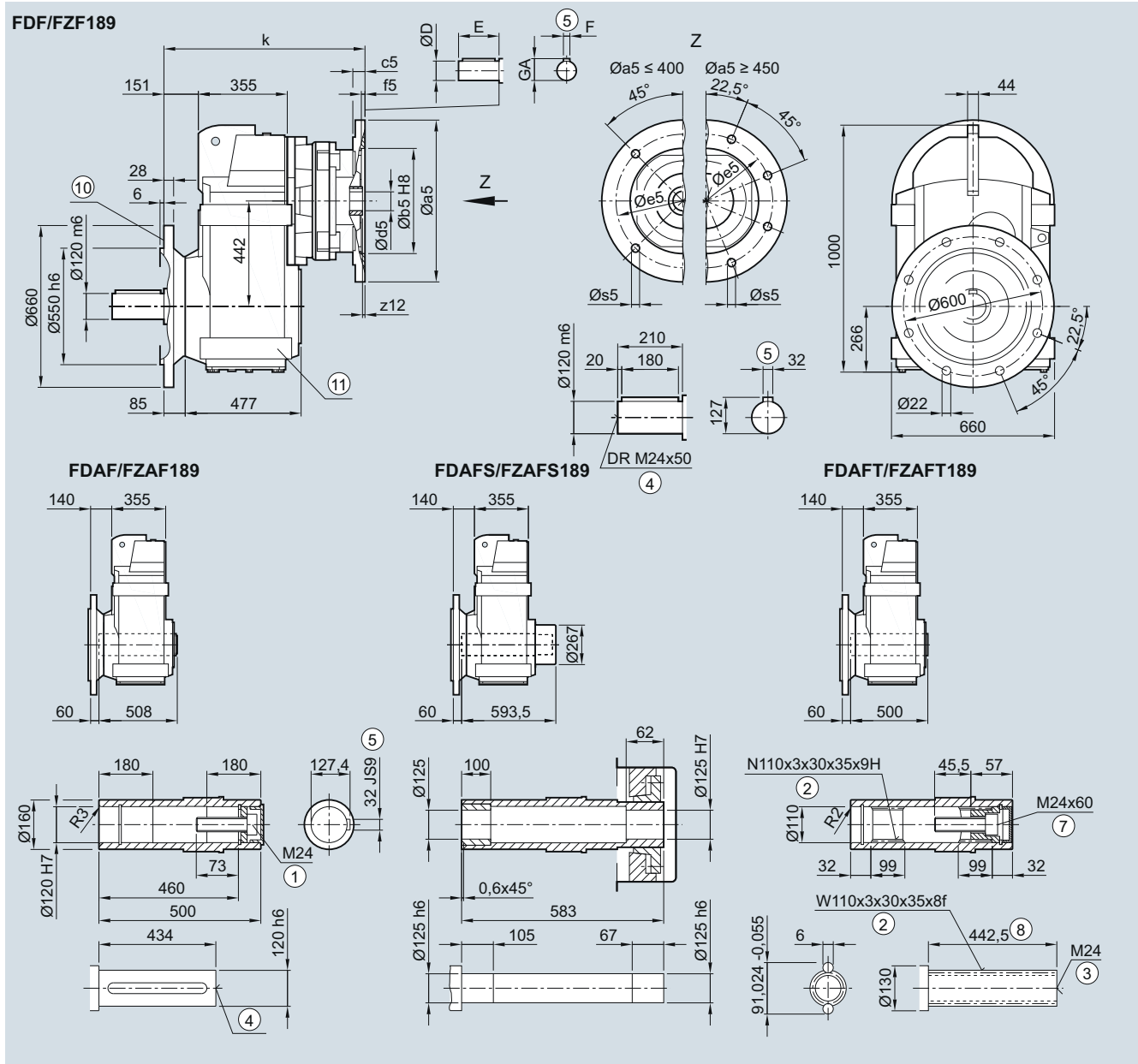

Adapter	a5	b5	c5	f5	e5	s5	z12	d5/D	E	F	GA	k
112	250	180	14	5.0	215	M12x21	7.5	28	60	8	31.0	601.5
132	300	230	12	5.0	265	M12x20	3.0	38	80	10	41.0	611.5
160	350	250	15	6.0	300	M16x25	3.0	42	110	12	45.0	641.5
180	350	250	15	6.0	300	M16x25	3.0	48	110	14	51.5	641.5
200	400	300	20	6.0	350	M16x29	7.0	55	110	16	59.0	681.5
225	450	350	20	6	400	M16x29	7.0	60	140	18	64.0	687.0
250	550	450	20	6.0	500	M16x29	10.0	65	140	18	69.0	717.5

- ① ISO 4014 ② DIN 5480 ③ DIN 332-D ④ DIN 332 ⑤ Feather key/keyway DIN 6885
- ⑦ ISO 4762 ⑥ Without locating shoulder +1 mm ⑩ For inner contour, see page 4/129 ⑪ Use bores only for foot-mounted design

4

FD../FZ..189 gearbox in a foot-mounted design

F030K4, FA030K4, FAS030K4, FAT030K4

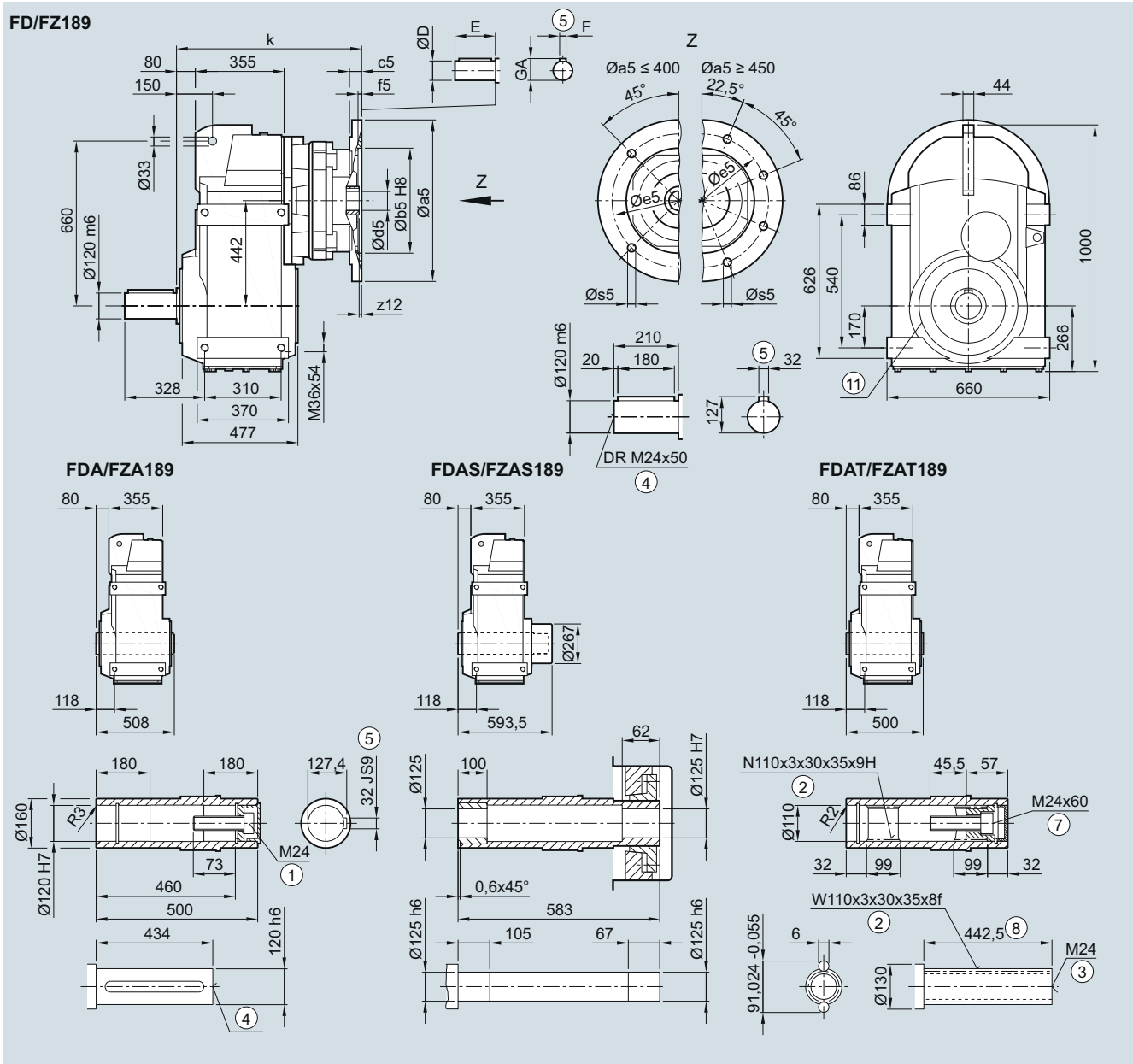

Adapter	a5	b5	c5	f5	e5	s5	z12	d5/D	E	F	GA	k
112	250	180	14	5.0	215	M12x21	7.5	28	60	8	31.0	530.5
132	300	230	12	5.0	265	M12x20	3.0	38	80	10	41.0	540.5
160	350	250	15	6.0	300	M16x25	3.0	42	110	12	45.0	570.5
180	350	250	15	6.0	300	M16x25	3.0	48	110	14	51.5	570.5
200	400	300	20	6.0	350	M16x29	7.0	55	110	16	59.0	610.5
225	450	350	20	6	400	M16x29	7.0	60	140	18	64.0	616.0
250	550	450	20	6.0	500	M16x29	10.0	65	140	18	69.0	646.5

- ① ISO 4014 ② DIN 5480 ③ DIN 332-D ④ DIN 332
- ⑤ Feather key/keyway DIN 6885 ⑦ ISO 4762 ⑧ Without locating shoulder +1 mm ⑩ Use bores only for housing flange design

SIMOGEAR Gearboxes

Parallel shaft gearbox with adapter K2

Dimensions

FD.../FZ...29 to FD.../FZ...79 gearboxes

F.AD.030K2, F.Z.030K2, F.F.030K2, F..030K2

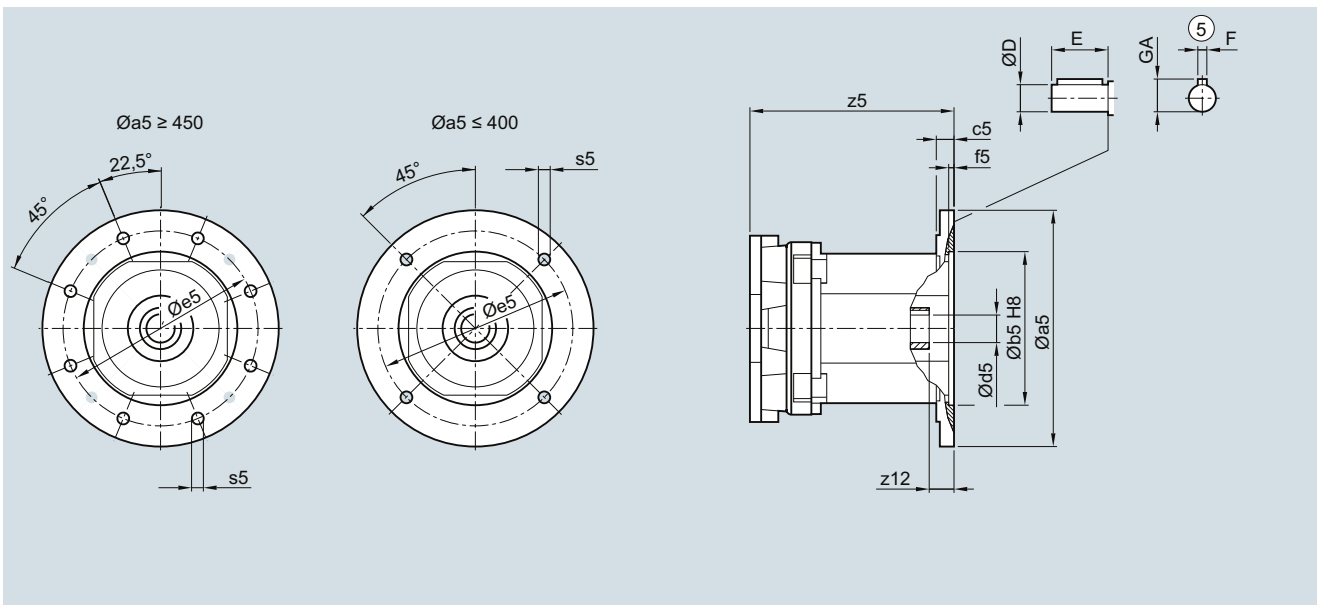

Adapter	a5	b5	c5	f5	e5	s5	z12	d5/D	E	F	GA	z5
FD.../FZ...29												
80	200	130	15	4.5	165	M10	15	19	40	6	21.5	198.0
90	200	130	15	4.5	165	M10	25	24	50	8	27.0	198.0
100	250	180	18	5.0	215	M12	30	28	60	8	31.0	245.0
FD.../FZ...39												
80	200	130	15	4.5	165	M10	15	19	40	6	21.5	198.0
90	200	130	15	4.5	165	M10	25	24	50	8	27.0	198.0
100	250	180	18	5.0	215	M12	30	28	60	8	31.0	245.0
112	250	180	18	5.0	215	M12	30	28	60	8	31.0	245.0
FD.../FZ...49												
80	200	130	15	4.5	165	M10	15	19	40	6	21.5	188.5
90	200	130	15	4.5	165	M10	25	24	50	8	27.0	188.5
100	250	180	18	5.0	215	M12	30	28	60	8	31.0	235.5
112	250	180	18	5.0	215	M12	30	28	60	8	31.0	235.5
132	300	230	18	5.0	265	M12	45	38	80	10	41.0	313.5
FD.../FZ...69												
80	200	130	15	4.5	165	M10	15	19	40	6	21.5	188.5
90	200	130	15	4.5	165	M10	25	24	50	8	27.0	188.5
100	250	180	18	5.0	215	M12	30	28	60	8	31.0	235.5
112	250	180	18	5.0	215	M12	30	28	60	8	31.0	235.5
132	300	230	18	5.0	265	M12	45	38	80	10	41.0	313.5
FD.../FZ...79												
80	200	130	15	4.5	165	M10	15	19	40	6	21.5	182.5
90	200	130	15	4.5	165	M10	25	24	50	8	27.0	182.5
100	250	180	18	5.0	215	M12	30	28	60	8	31.0	229.5
112	250	180	18	5.0	215	M12	30	28	60	8	31.0	229.5
132	300	230	18	5.0	265	M12	45	38	80	10	41.0	307.5
160	350	250	25	6.0	300	M16	66	42	110	12	45.0	352.5

© Feather key/keyway DIN 6885

FD.../FZ...89 to FD.../FZ...129 gearboxes

F.AD.030K2, F.Z.030K2, F.F.030K2, F..030K2

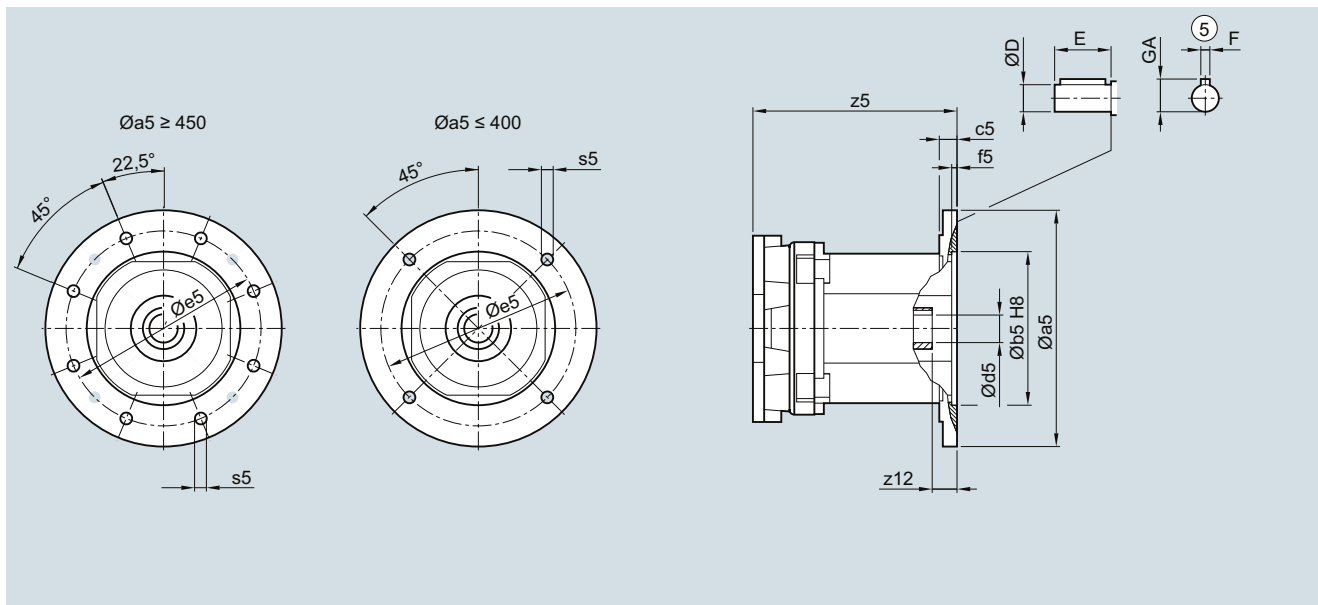

Adapter	a5	b5	c5	f5	e5	s5	z12	d5/D	E	F	GA	z5
FD.../FZ...89												
80	200	130	15	4.5	165	M10	15	19	40	6	21.5	169.5
90	200	130	15	4.5	165	M10	25	24	50	8	27.0	169.5
100	250	180	18	5.0	215	M12	30	28	60	8	31.0	212.5
112	250	180	18	5.0	215	M12	30	28	60	8	31.0	212.5
132	300	230	18	5.0	265	M12	45	38	80	10	41.0	290.5
160	350	250	25	6.0	300	M16	66	42	110	12	45.0	335.5
FD.../FZ...109												
90	200	130	15	4.5	165	M10	25	24	50	8	27.0	162.5
100	250	180	18	5.0	215	M12	30	28	60	8	31.0	203.5
112	250	180	18	5.0	215	M12	30	28	60	8	31.0	203.5
132	300	230	18	5.0	265	M12	45	38	80	10	41.0	281.5
160	350	250	25	6.0	300	M16	66	42	110	12	45.0	326.5
180	350	250	25	6.0	300	M16	59	48	110	14	51.5	326.5
200	400	300	20	6.0	350	M16x29	60	55	110	16	59.0	371.5
225	450	350	50	6.0	400	M16x29	84 (36)	60 (55)	140 (110)	18 (16)	64.0 (59.0)	419.0
FD.../FZ...129												
90	200	130	15	4.5	165	M10	25	24	50	8	27.0	155.5
100	250	180	18	5.0	215	M12	30	28	60	8	31.0	194.5
112	250	180	18	5.0	215	M12	30	28	60	8	31.0	194.5
132	300	230	18	5.0	265	M12	45	38	80	10	41.0	270.5
160	350	250	25	6.0	300	M16	66	42	110	12	45.0	315.5
180	350	250	25	6.0	300	M16	59	48	110	14	51.5	315.5
200	400	300	20	6.0	350	M16x29	60	55	110	16	59.0	360.5
225	450	350	50	6.0	400	M16x29	84 (36)	60 (55)	140 (110)	18 (16)	64.0 (59.0)	414.0
250	550	450	27	6.0	500	M16	75	65	140	18	69.0	445.5

⑨ Feather key/keyway DIN 6885

() Dimension in brackets for 2-pole motor

SIMOGEAR Gearboxes

Parallel shaft gearbox with adapter K2

Dimensions

FD.../FZ...149 to FD.../FZ...189 gearboxes

F.AD.030K2, F.Z.030K2, F.F.030K2, F..030K2

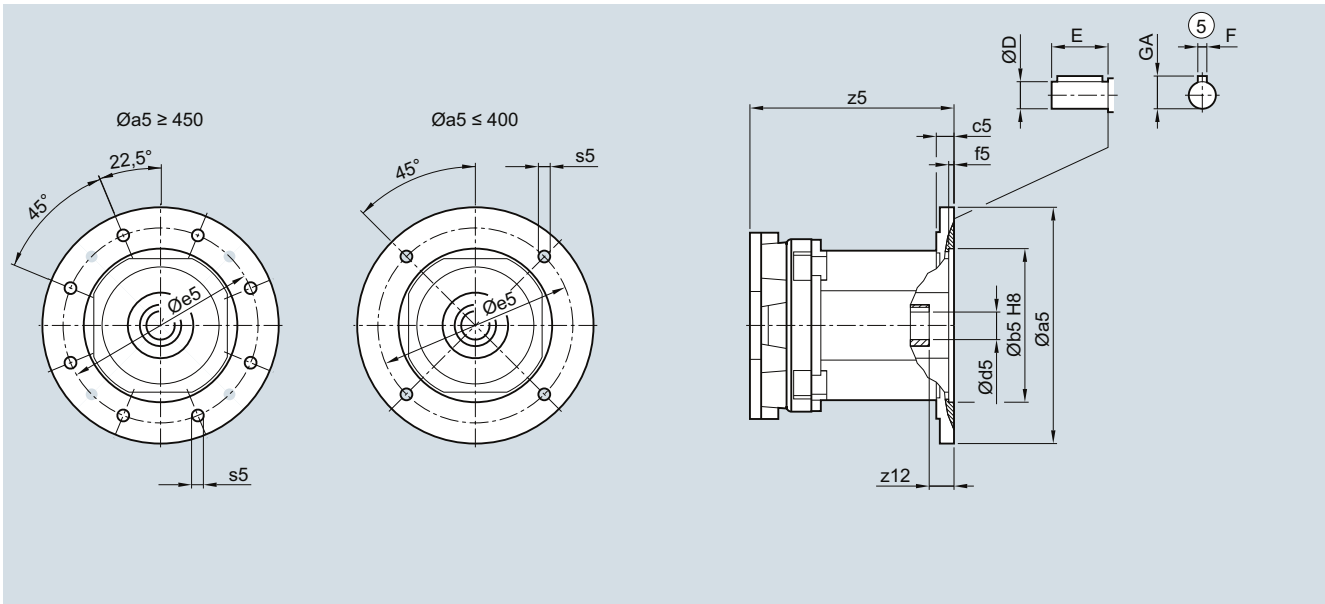

Adapter	a5	b5	c5	f5	e5	s5	z12	d5/D	E	F	GA	z5
FD.../FZ...149												
100	250	180	18	5.0	215	M12	30	28	60	8	31.0	193.0
112	250	180	18	5.0	215	M12	30	28	60	8	31.0	193.0
132	300	230	18	5.0	265	M12	45	38	80	10	41.0	264.0
160	350	250	25	6.0	300	M16	66	42	110	12	45.0	309.0
180	350	250	25	6.0	300	M16	59	48	110	14	51.5	309.0
200	400	300	20	6.0	350	M16x29	60	55	110	16	59.0	354.0
225	450	350	50	6.0	400	M16x29	84 (36)	60 (55)	140 (110)	18 (16)	64.0 (59.0)	401.5
250	550	450	27	6.0	500	M16	75	65	140	18	69.0	439.0
280	550	450	27	6.0	500	M16	51	75 (65)	140	20 (18)	79.5 (69.0)	314.5
FD.../FZ...169												
112	250	180	18	5.0	215	M12	30	28	60	8	31.0	180.5
132	300	230	18	5.0	265	M12	45	38	80	10	41.0	251.0
160	350	250	25	6.0	300	M16	66	42	110	12	45.0	296.0
180	350	250	25	6.0	300	M16	59	48	110	14	51.5	296.0
200	400	300	20	6.0	350	M16x29	60	55	110	16	59.0	340.5
225	450	350	50	6.0	400	M16x29	84 (36)	60 (55)	140 (110)	18 (16)	64.0 (59.0)	387.0
250	550	450	27	6.0	500	M16	75	65	140	18	69.0	420.5
280	550	450	27	6.0	500	M16	51	75 (65)	140	20 (18)	79.5 (69.0)	297.5
FD.../FZ...189												
112	250	180	18	5.0	215	M12	30	28	60	8	31.0	180.5
132	300	230	18	5.0	265	M12	45	38	80	10	41.0	251.0
160	350	250	25	6.0	300	M16	66	42	110	12	45.0	296.0
180	350	250	25	6.0	300	M16	59	48	110	14	51.5	296.0
200	400	300	20	6.0	350	M16x29	60	55	110	16	59.0	340.5
225	450	350	50	6.0	400	M16x29	84 (36)	60 (55)	140 (110)	18 (16)	64.0 (59.0)	387.0
250	550	450	27	6.0	500	M16	75	65	140	18	69.0	420.5
280	550	450	27	6.0	500	M16	51	75 (65)	140	20 (18)	79.5 (69.0)	297.5
315	660	550	33	8.0	600	M20	33.5	80 (65)	170 (140)	22 (18)	85.0 (69.0)	321.5

⑤ Feather key/keyway DIN 6885

() Dimension in brackets for 2-pole motor

FDAD./FZAD.29 gearbox in a shaft-mounted design

FAD030KQ, FADS030KQ

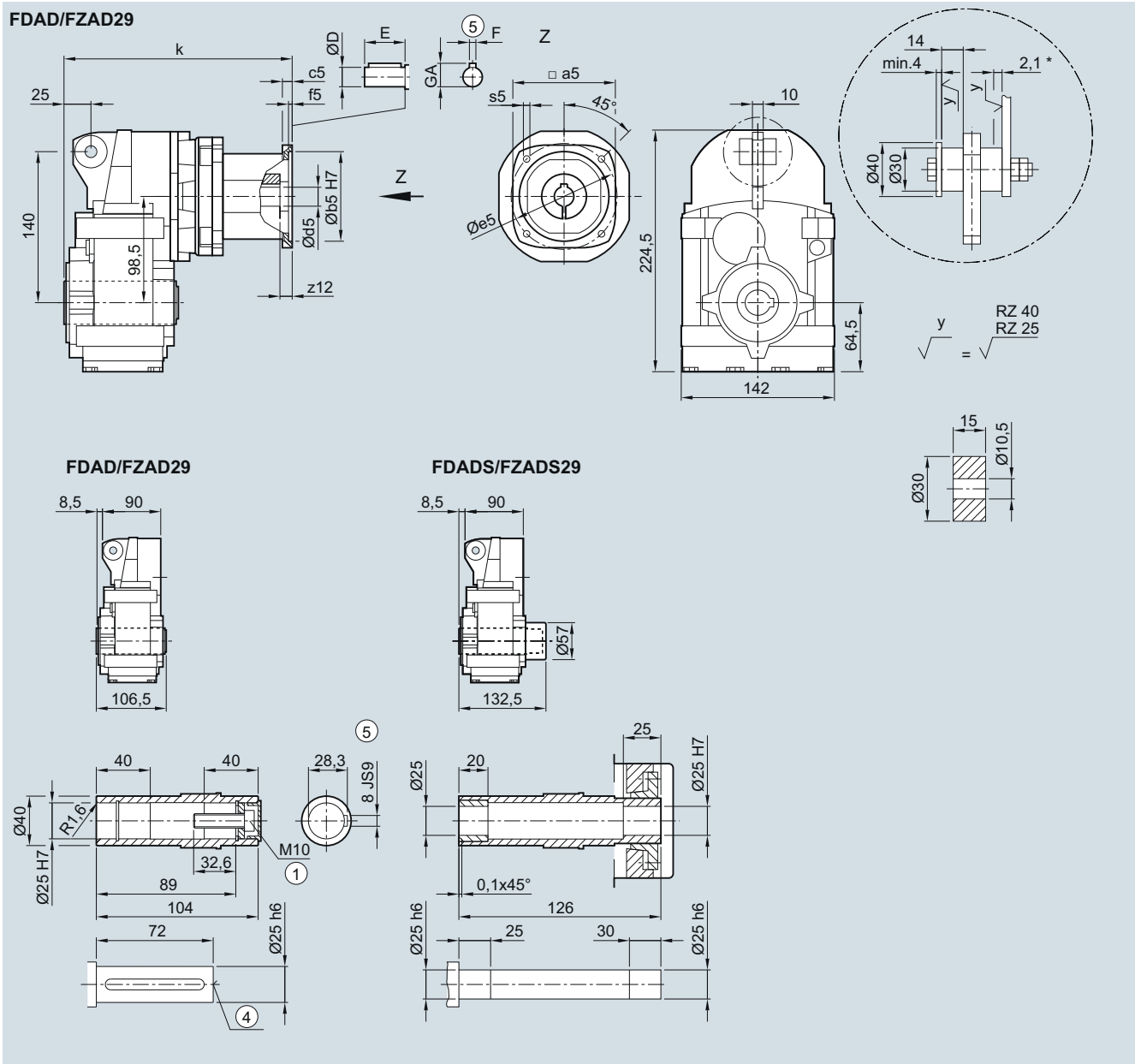

Adapter	a5	b5	c5	f5	e5	s5	z12	d5/D	E	F	GA	k
703	71.6	60	9	4.0	75	M5	18	14	30	5	16.0	199
704	96.5	80	10	4.0	100	M6	14	19	40	6	21.5	246
706	126.0	110	12	4.5	130	M8	15	24	50	8	27.0	259

① ISO 4017

④ DIN 332

⑤ Feather key/keyway DIN 6885

* Spring compression at max. torque

SIMOGEAR Gearboxes

Parallel shaft gearbox with adapter KQ

Dimensions

FD.Z./FZ.Z.29 gearbox in a housing flange design

FDZ030KQ, FAZ030KQ, FAZS030KQ

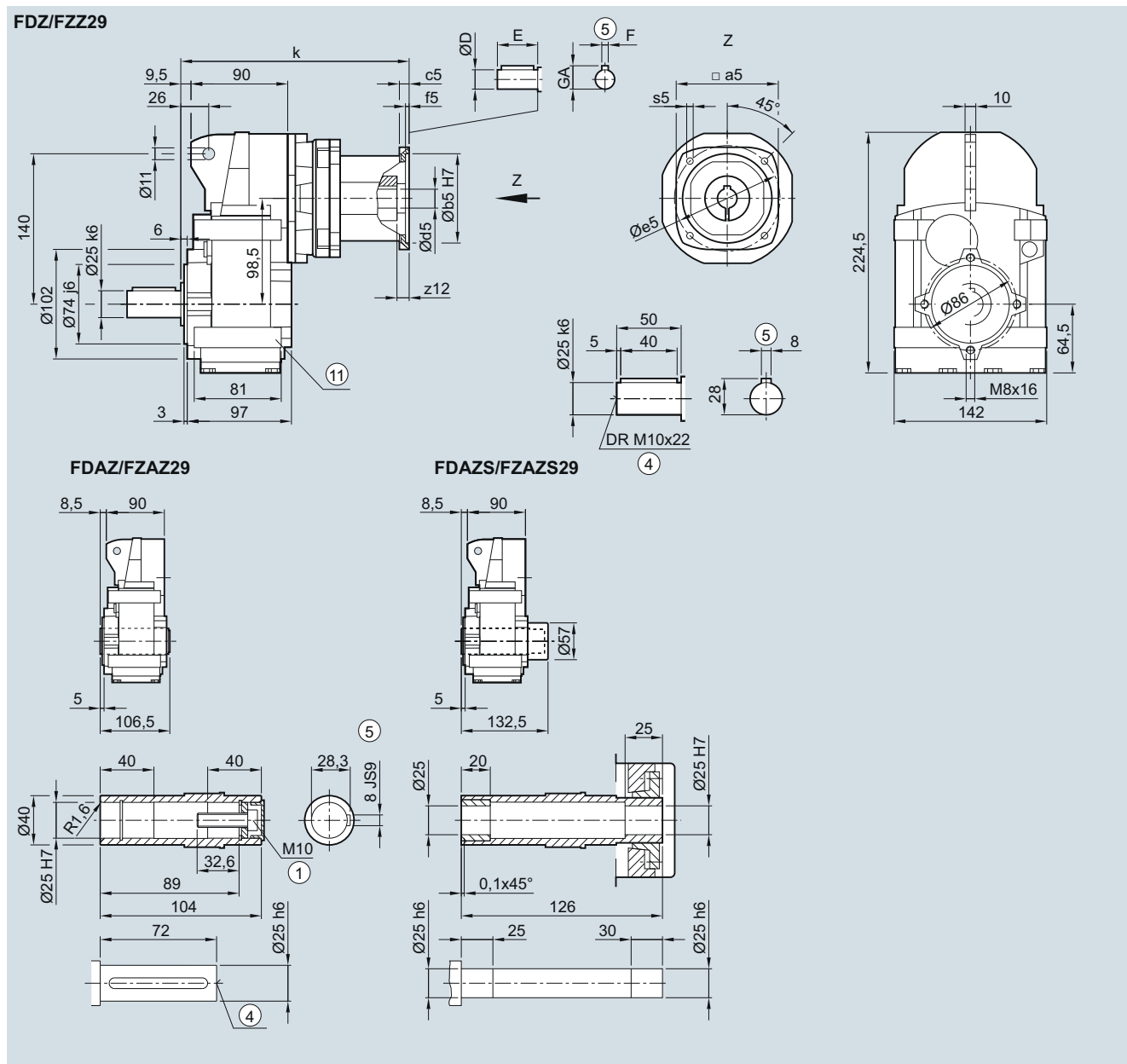

Adapter	a5	b5	c5	f5	e5	s5	z12	d5/D	E	F	GA	k
703	71.6	60	9	4.0	75	M5	18	14	30	5	16.0	199
704	96.5	80	10	4.0	100	M6	14	19	40	6	21.5	246
706	126.0	110	12	4.5	130	M8	15	24	50	8	27.0	259

① ISO 4017

④ DIN 332

⑤ Feather key/keyway DIN 6885

⑩ Use bores only for foot-mounted design

SIMOGEAR Gearboxes

Parallel shaft gearbox with adapter KQ

Dimensions

FD.F./FZ.F.29 gearbox in a flange-mounted design

FF030KQ, FAF030KQ, FAFS030KQ

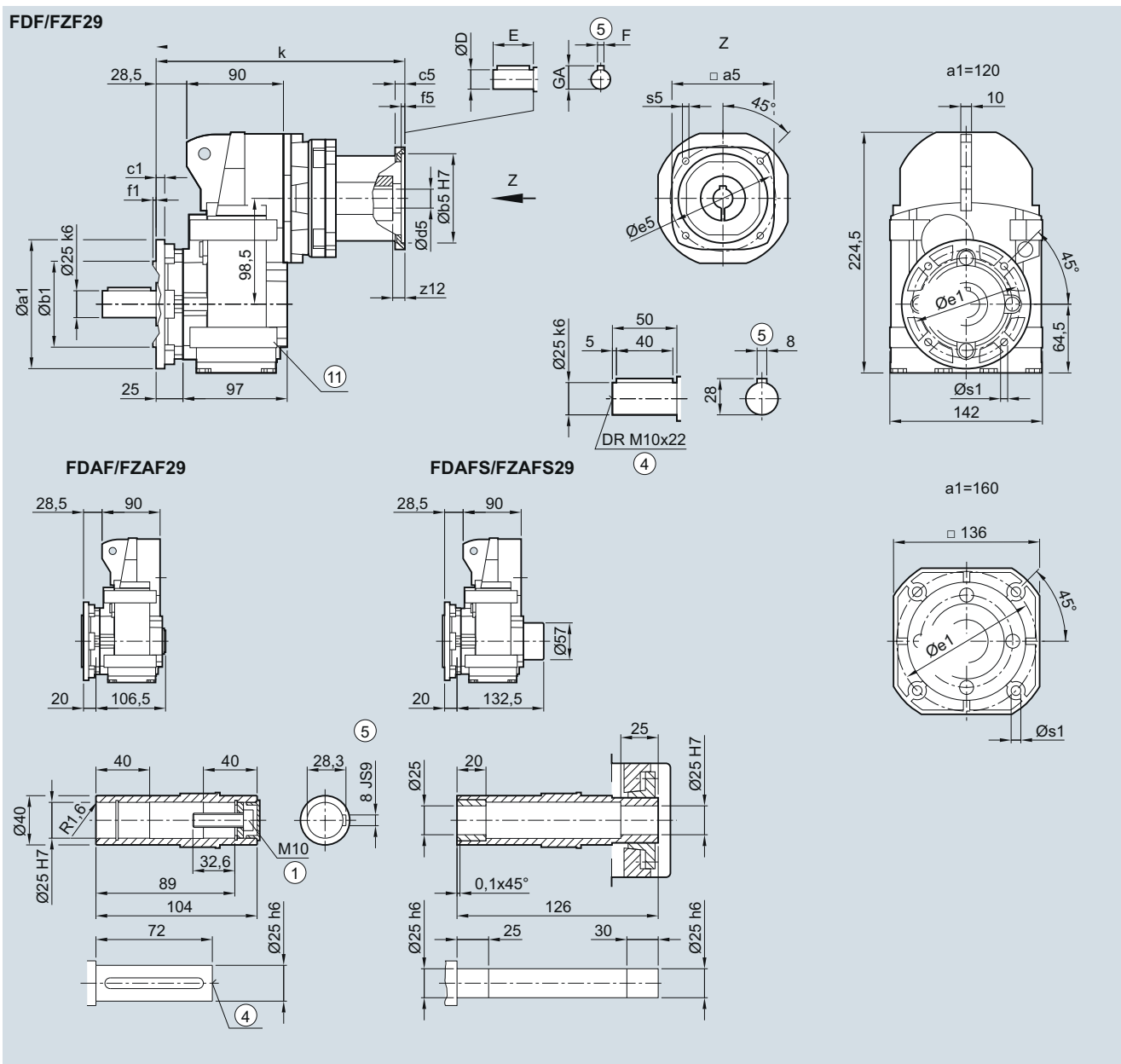

Flange	a1	b1	to2	c1	e1	f1	s1					
	120	80	j6	8	100	3.0	6.6					
	160	110	j6	9	130	3.5	9.0					
Adapter	a5	b5	c5	f5	e5	s5	z12	d5/D	E	F	GA	k
703	71.6	60	9	4.0	75	M5	18	14	30	5	16.0	218
704	96.5	80	10	4.0	100	M6	14	19	40	6	21.5	265
706	126.0	110	12	4.5	130	M8	15	24	50	8	27.0	278

① ISO 4014

④ DIN 332

⑤ Feather key/keyway DIN 6885

⑩ For inner contour, see page 4/129

⑪ Use bores only for foot-mounted design

SIMOGEAR Gearboxes

Parallel shaft gearbox with adapter KQ

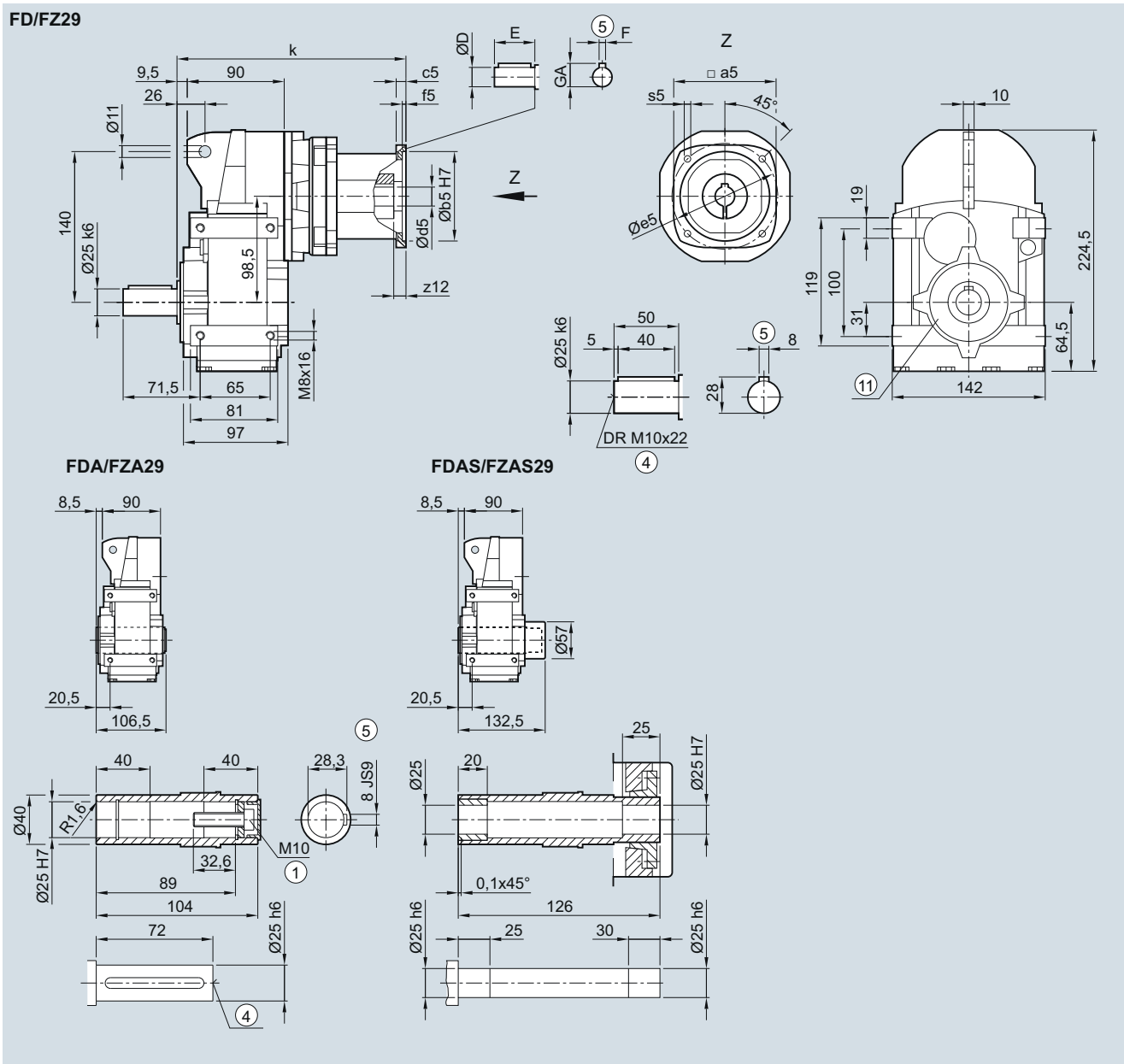
Dimensions**FD../FZ..29 gearbox in a foot-mounted design****F030KQ, FA030KQ, FAS030KQ**

Adapter	a5	b5	c5	f5	e5	s5	z12	d5/D	E	F	GA	k
703	71.6	60	9	4.0	75	M5	18	14	30	5	16.0	199
704	96.5	80	10	4.0	100	M6	14	19	40	6	21.5	246
706	126.0	110	12	4.5	130	M8	15	24	50	8	27.0	259

① ISO 4017

④ DIN 332

⑤ Feather key/keyway DIN 6885

⑪ Use bores only for housing flange design

FDAD./FZAD.39 gearbox in a shaft-mounted design

FAD030KQ, FADS030KQ, FADT030KQ

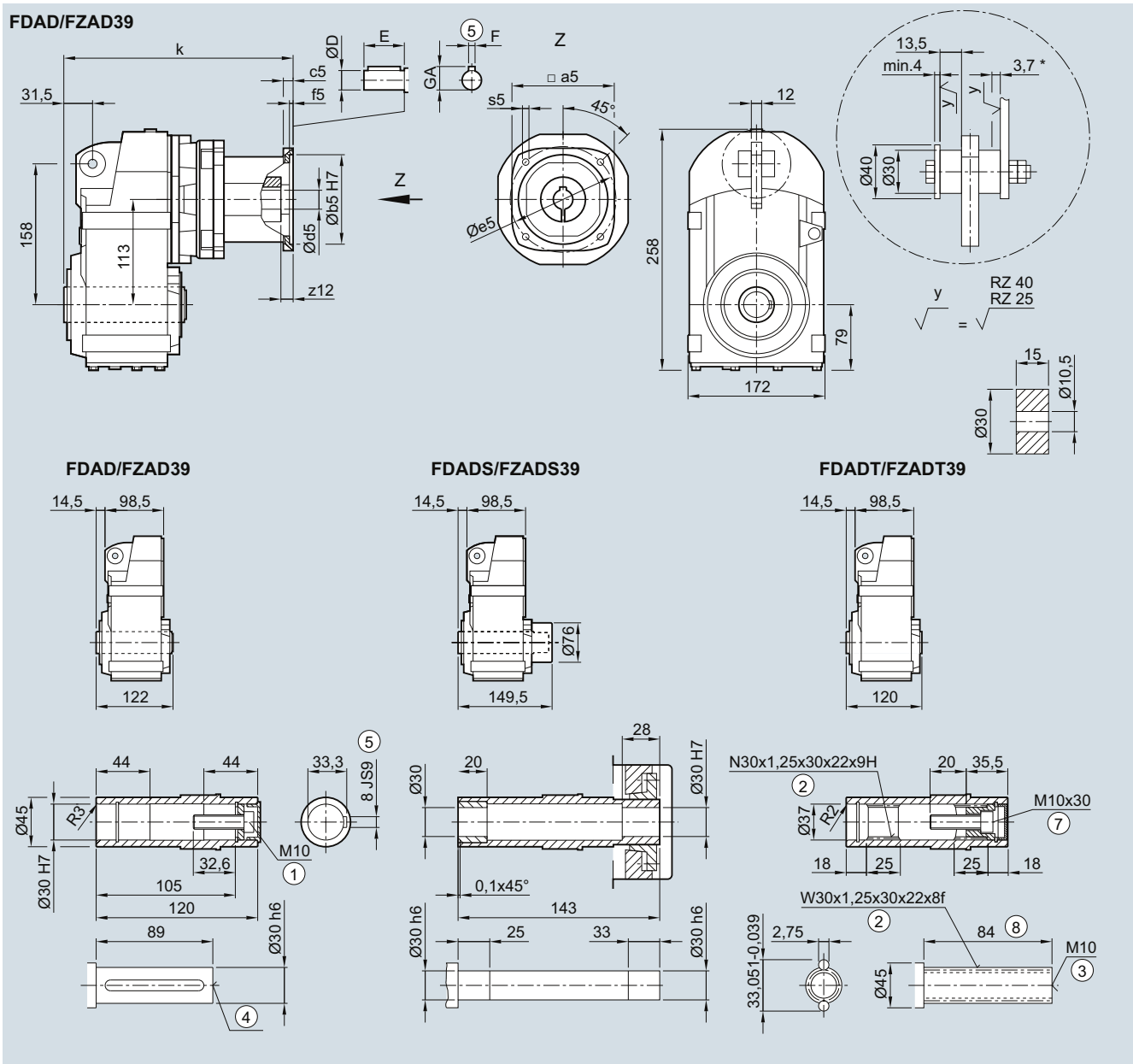

4

Adapter	a5	b5	c5	f5	e5	s5	z12	d5/D	E	F	GA	k
703	71.6	60	9	4.0	75	M5	18.0	14	30	5	16.0	212.5
704	96.5	80	10	4.0	100	M6	14.0	19	40	6	21.5	259.5
706	126.0	110	12	4.5	130	M8	15.0	24	50	8	27.0	272.5
708	155.0	130	15	4.5	165	M10	23.5	32	58	10	35.0	316.0

① ISO 4014 ② DIN 5480 ③ DIN 332-D ④ DIN 332 ⑤ Feather key/keyway DIN 6885 ⑦ ISO 4762 ⑥ Without locating shoulder +1 mm

* Spring compression at max. torque

SIMOGEAR Gearboxes

Parallel shaft gearbox with adapter KQ

Dimensions

FD.Z./FZ.Z.39 gearbox in a housing flange design

FDZ030KQ, FAZ030KQ, FAZS030KQ, FAZT030KQ

FDZ/FZZ39

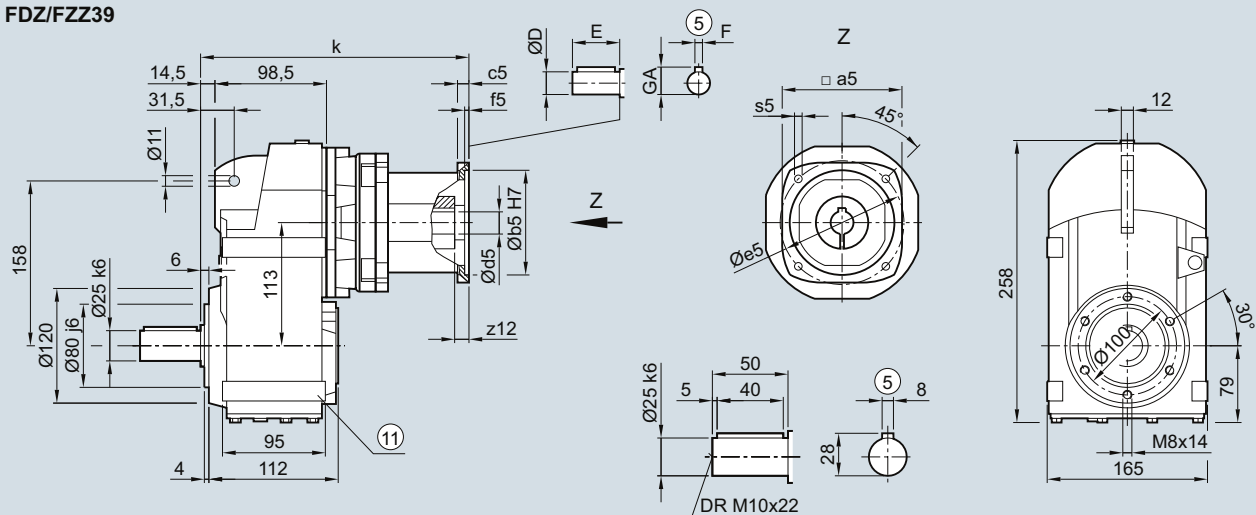

FDAZ/FAZ39

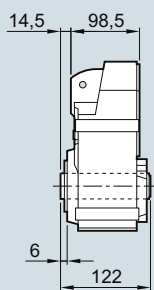

FDAZS/FAZS39

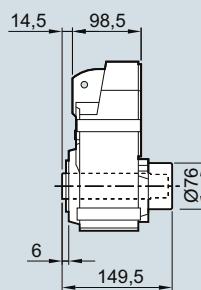

FDAZT/FAZT39

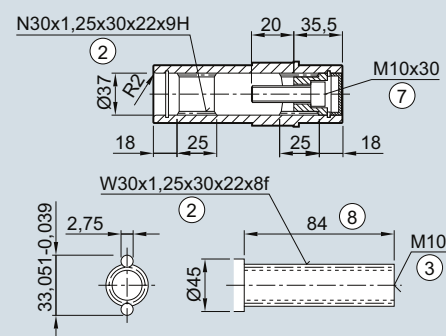
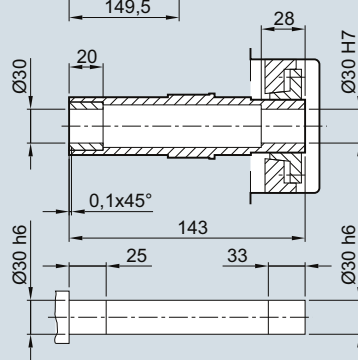
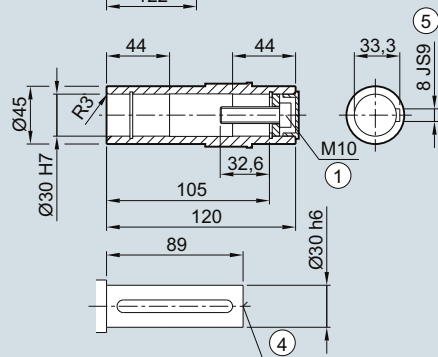
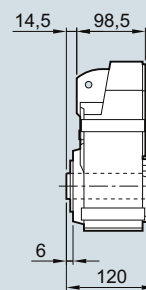

Adapter	a5	b5	c5	f5	e5	s5	z12	d5/D	E	F	GA	k
703	71.6	60	9	4.0	75	M5	18.0	14	30	5	16.0	212.5
704	96.5	80	10	4.0	100	M6	14.0	19	40	6	21.5	259.5
706	126.0	110	12	4.5	130	M8	15.0	24	50	8	27.0	272.5
708	155.0	130	15	4.5	165	M10	23.5	32	58	10	35.0	316.0

① ISO 4014

② DIN 5480

③ DIN 332-D

④ DIN 332

⑤ Feather key/keyway DIN 6885

⑦ ISO 4762

⑧ Without locating shoulder +1 mm

⑩ Use bores only for foot-mounted design

FD.F./FZ.F.39 in a flange-mounted design

FF030KQ, FAF030KQ, FAFS030KQ, FAFT030KQ

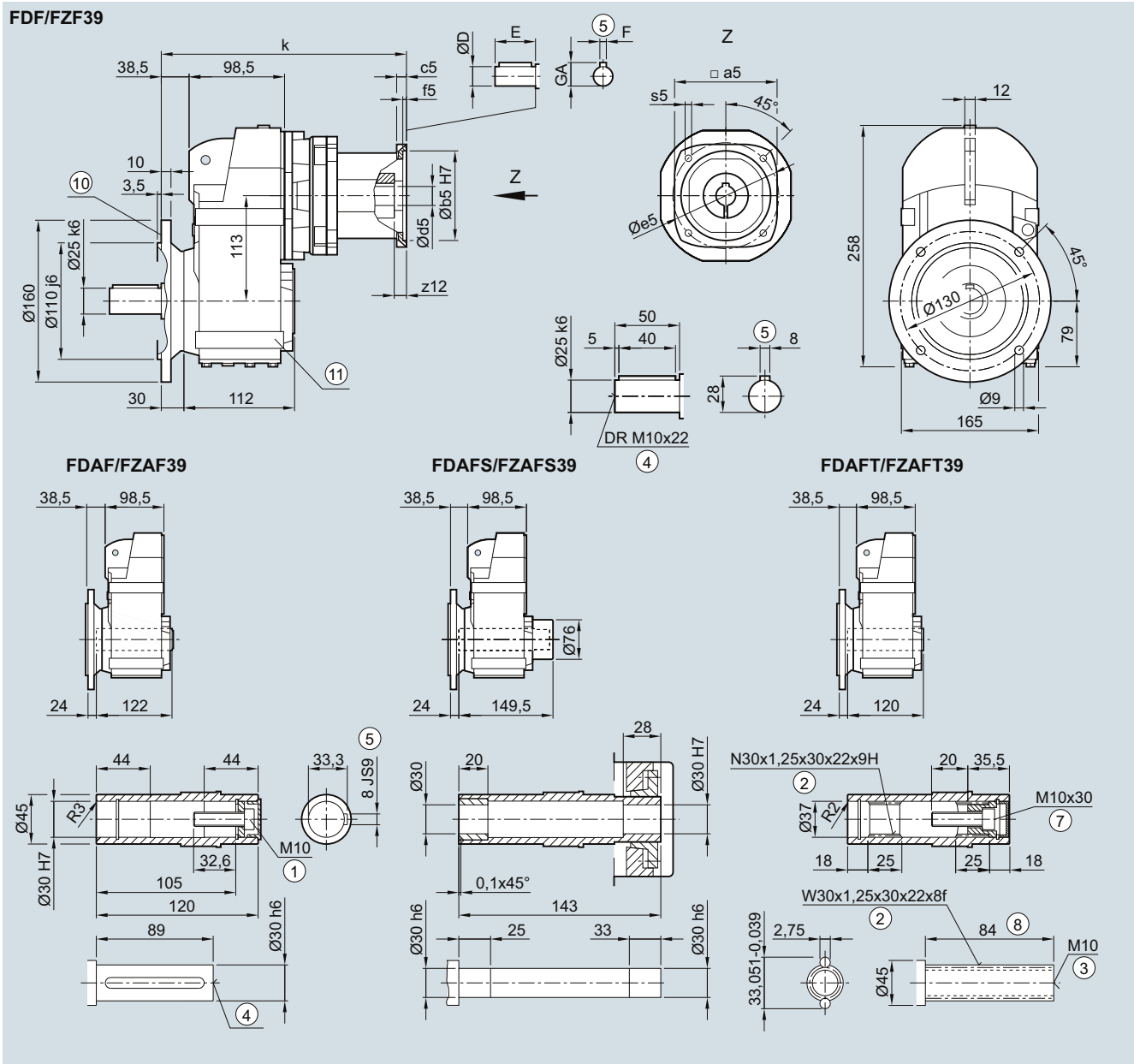

4

Adapter	a5	b5	c5	f5	e5	s5	z12	d5/D	E	F	GA	k
703	71.6	60	9	4.0	75	M5	18.0	14	30	5	16.0	236.5
704	96.5	80	10	4.0	100	M6	14.0	19	40	6	21.5	283.5
706	126.0	110	12	4.5	130	M8	15.0	24	50	8	27.0	296.5
708	155.0	130	15	4.5	165	M10	23.5	32	58	10	35.0	340.0

① ISO 4014 ② DIN 5480 ③ DIN 332-D ④ DIN 332 ⑤ Feather key/keyway DIN 6885
 ⑦ ISO 4762 ⑥ Without locating shoulder +1 mm ⑩ For inner contour, see page 4/129 ⑧ Use bores only for foot-mounted design

SIMOGEAR Gearboxes

Parallel shaft gearbox with adapter KQ

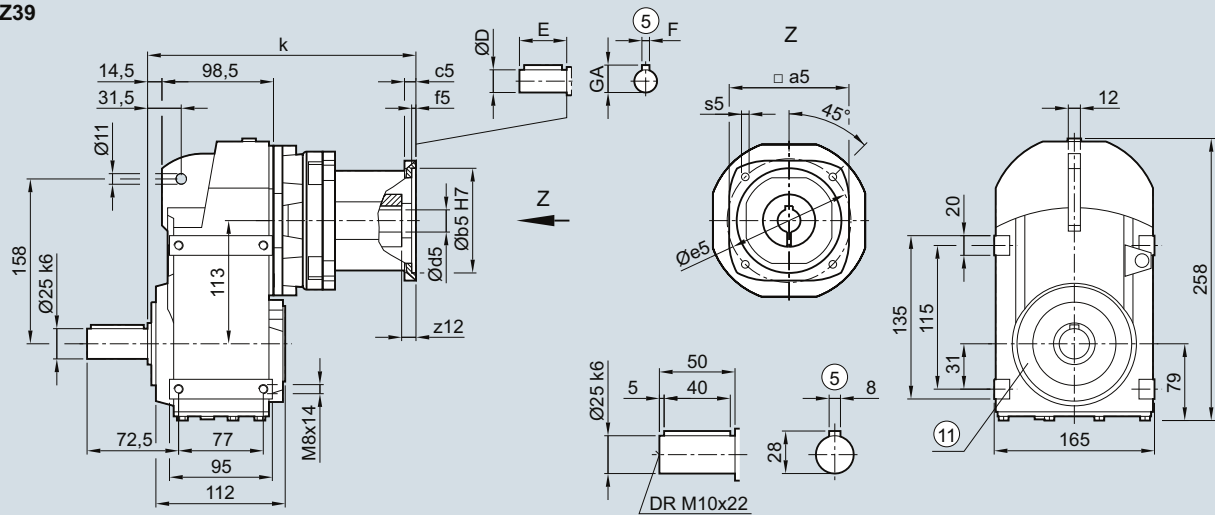
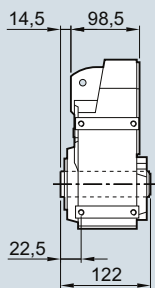
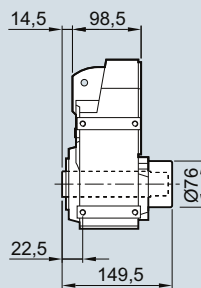
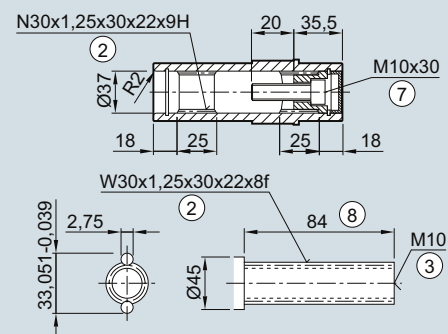
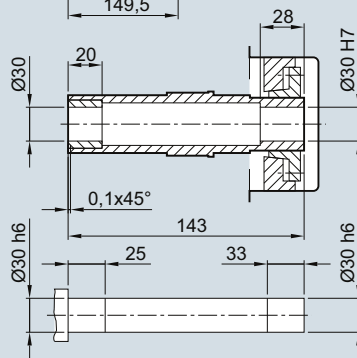
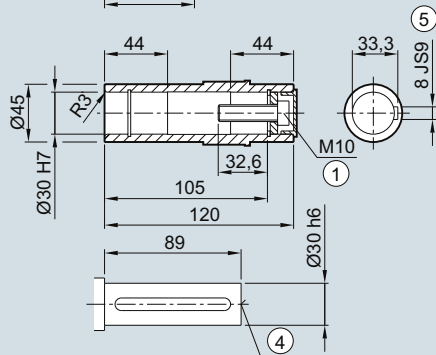
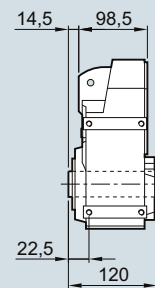
Dimensions**FD../FZ..39 gearbox in a foot-mounted design****F030KQ, FA030KQ, FAS030KQ, FAT030KQ****FD/FZ39****FDA/FZA39****FDAS/FZAS39****FDAT/FZAT39**

Adapter	a5	b5	c5	f5	e5	s5	z12	d5/D	E	F	GA	k
703	71.6	60	9	4.0	75	M5	18.0	14	30	5	16.0	212.5
704	96.5	80	10	4.0	100	M6	14.0	19	40	6	21.5	259.5
706	126.0	110	12	4.5	130	M8	15.0	24	50	8	27.0	272.5
708	155.0	130	15	4.5	165	M10	23.5	32	58	10	35.0	316.0

① ISO 4014

② DIN 5480

③ DIN 332-D

④ DIN 332

⑤ Feather key/keyway DIN 6885

⑦ ISO 4762

⑧ Without locating shoulder +1 mm

⑩ Use bores only for housing flange design

FDAD/FZAD.49 gearbox in a shaft-mounted design

FAD030KQ, FADS030KQ, FADT030KQ

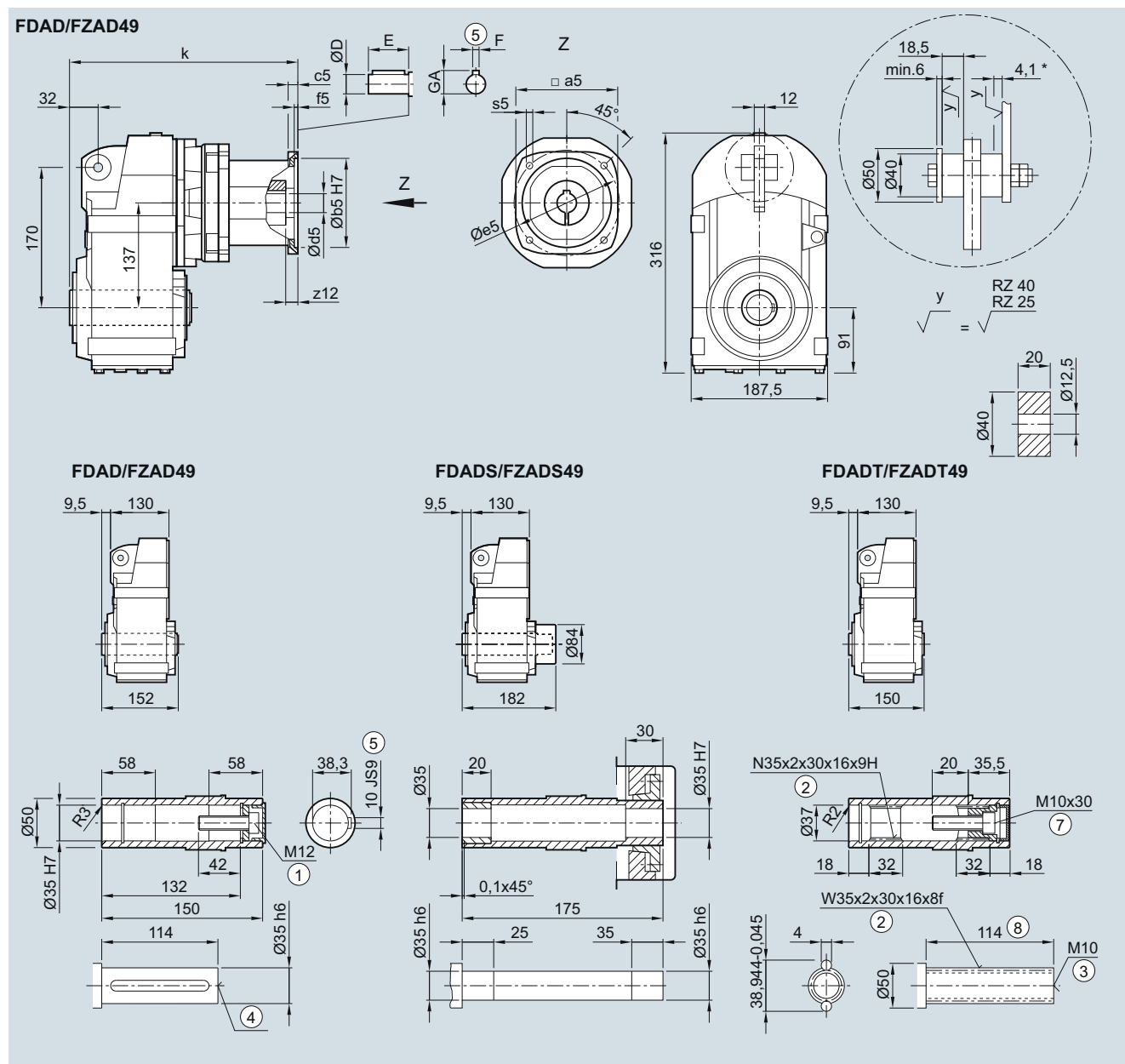

Adapter	a5	b5	c5	f5	e5	s5	z12	d5/D	E	F	GA	k
703	71.6	60	9	4.0	75	M5	18.0	14	30	5	16.0	229.5
704	96.5	80	10	4.0	100	M6	14.0	19	40	6	21.5	276.5
706	126.0	110	12	4.5	130	M8	15.0	24	50	8	27.0	289.5
708	155.0	130	15	4.5	165	M10	23.5	32	58	10	35.0	333.0
710	192.5	180	18	5.0	215	M12	33.0	38	80	10	41.0	402.0

① ISO 4014 ② DIN 5480 ③ DIN 332-D ④ DIN 332 ⑤ Feather key/keyway DIN 6885 ⑦ ISO 4762 ⑧ Without locating shoulder +1 mm

* Spring compression at max. torque

SIMOGEAR Gearboxes

Parallel shaft gearbox with adapter KQ

Dimensions

FD.Z./FZ.Z.49 gearbox in a housing flange design

FDZ030KQ, FAZ030KQ, FAZS030KQ, FAZT030KQ

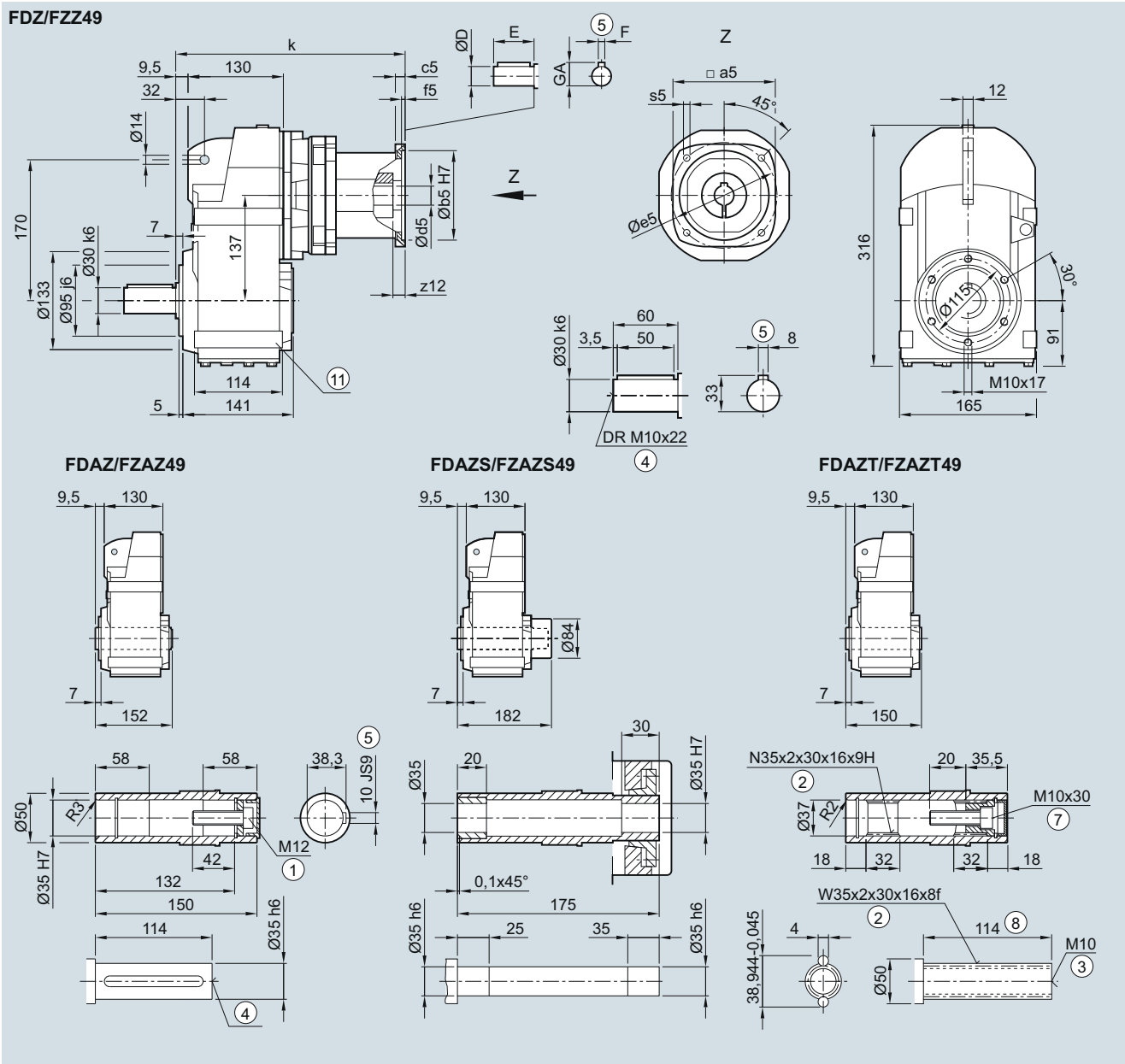

Adapter	a5	b5	c5	f5	e5	s5	z12	d5/D	E	F	GA	k
703	71.6	60	9	4.0	75	M5	18.0	14	30	5	16.0	229.5
704	96.5	80	10	4.0	100	M6	14.0	19	40	6	21.5	276.5
706	126.0	110	12	4.5	130	M8	15.0	24	50	8	27.0	289.5
708	155.0	130	15	4.5	165	M10	23.5	32	58	10	35.0	333.0
710	192.5	180	18	5.0	215	M12	33.0	38	80	10	41.0	402.0

① ISO 4014

② DIN 5480

③ DIN 332-D

④ DIN 332

⑤ Feather key/keyway DIN 6885

⑦ ISO 4762

⑧ Without locating shoulder +1 mm

⑩ Use bores only for foot-mounted design

SIMOGEAR Gearboxes

Parallel shaft gearbox with adapter KQ

Dimensions

FD.F./FZ.F.49 gearbox in a flange-mounted design

FF030KQ, FAF030KQ, FAFS030KQ, FAFT030KQ

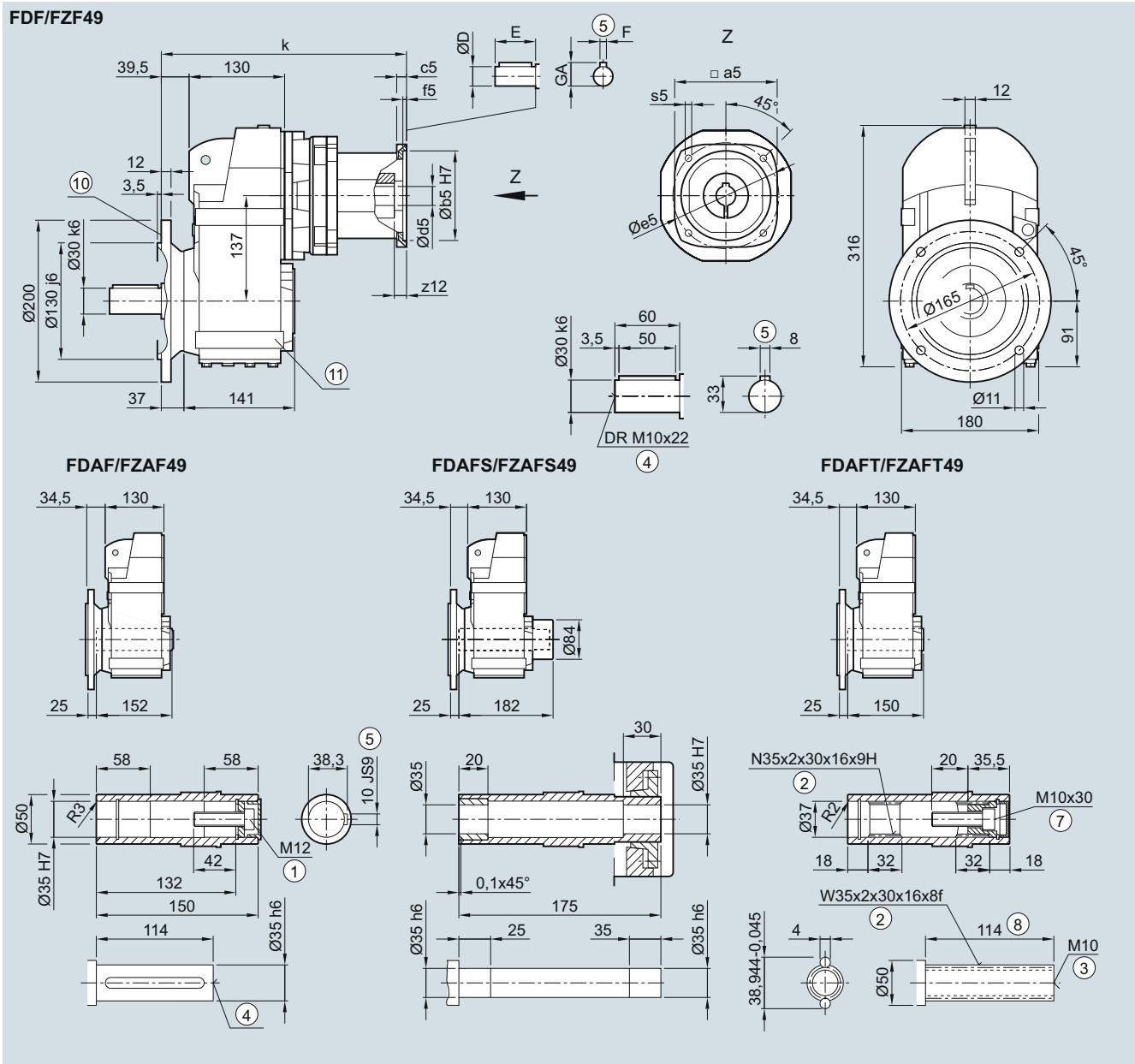

Adapter	a5	b5	c5	f5	e5	s5	z12	d5/D	E	F	GA	k
703	71.6	60	9	4.0	75	M5	18.0	14	30	5	16.0	259.5
704	96.5	80	10	4.0	100	M6	14.0	19	40	6	21.5	306.5
706	126.0	110	12	4.5	130	M8	15.0	24	50	8	27.0	319.5
708	155.0	130	15	4.5	165	M10	23.5	32	58	10	35.0	363.0
710	192.5	180	18	5.0	215	M12	33.0	38	80	10	41.0	432.0

- ① ISO 4014 ② DIN 5480 ③ DIN 332-D ④ DIN 332 ⑤ Feather key/keyway DIN 6885
- ⑦ ISO 4762 ⑥ Without locating shoulder +1 mm ⑩ For inner contour, see page 4/129 ⑪ Use bores only for foot-mounted design

SIMOGEAR Gearboxes

Parallel shaft gearbox with adapter KQ

Dimensions

FD../FZ..49 gearbox in a foot-mounted design

F030KQ, FA030KQ, FAS030KQ, FAT030KQ

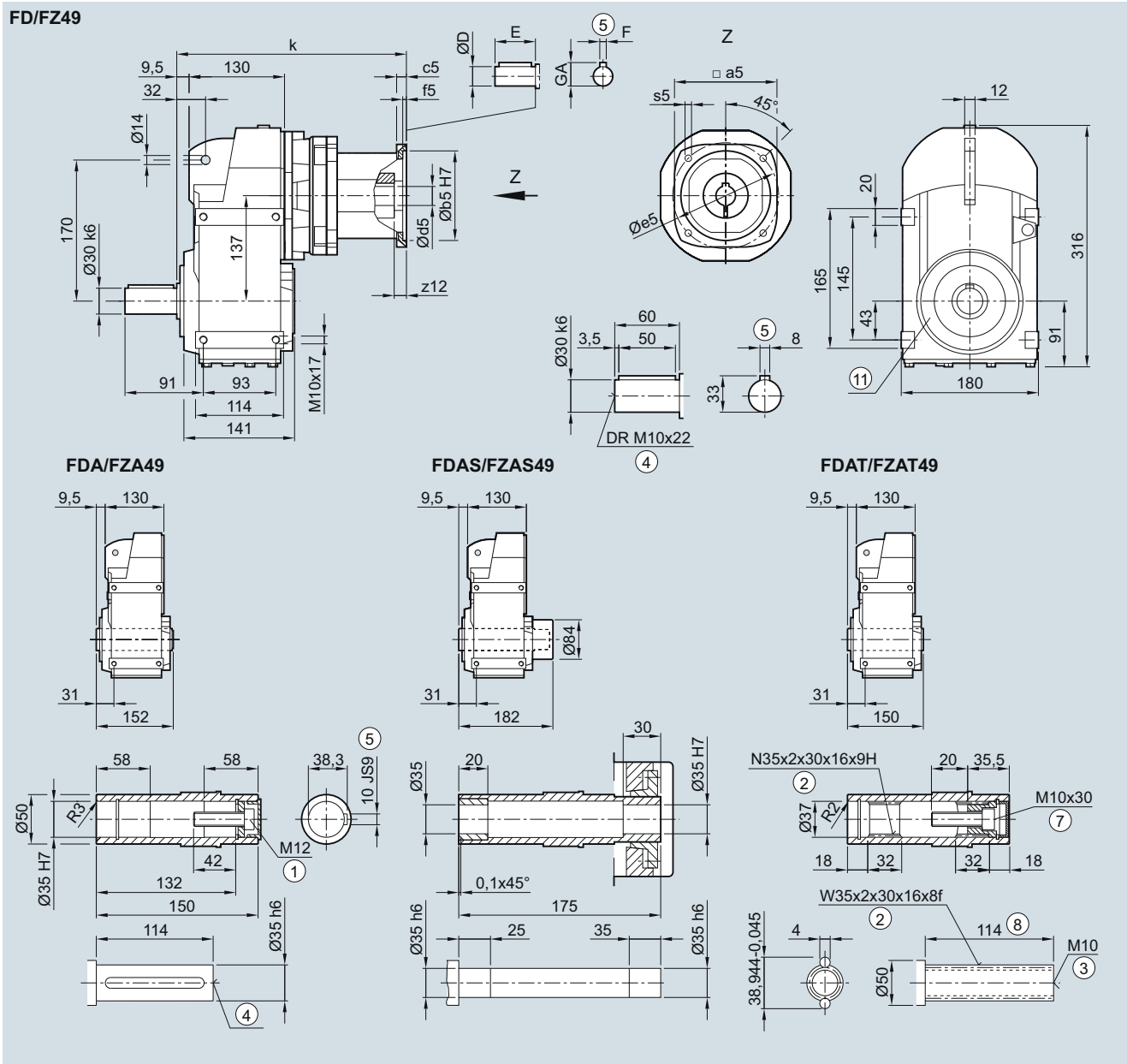

Adapter	a5	b5	c5	f5	e5	s5	z12	d5/D	E	F	GA	k
703	71.6	60	9	4.0	75	M5	18.0	14	30	5	16.0	229.5
704	96.5	80	10	4.0	100	M6	14.0	19	40	6	21.5	276.5
706	126.0	110	12	4.5	130	M8	15.0	24	50	8	27.0	289.5
708	155.0	130	15	4.5	165	M10	23.5	32	58	10	35.0	333.0
710	192.5	180	18	5.0	215	M12	33.0	38	80	10	41.0	402.0

① ISO 4014

② DIN 5480

③ DIN 332-D

④ DIN 332

⑤ Feather key/keyway DIN 6885

⑦ ISO 4762

⑧ Without locating shoulder +1 mm

⑩ Use bores only for housing flange design

FDAD./FZAD.69 gearbox in a shaft-mounted design

FAD030KQ, FADS030KQ, FADT030KQ

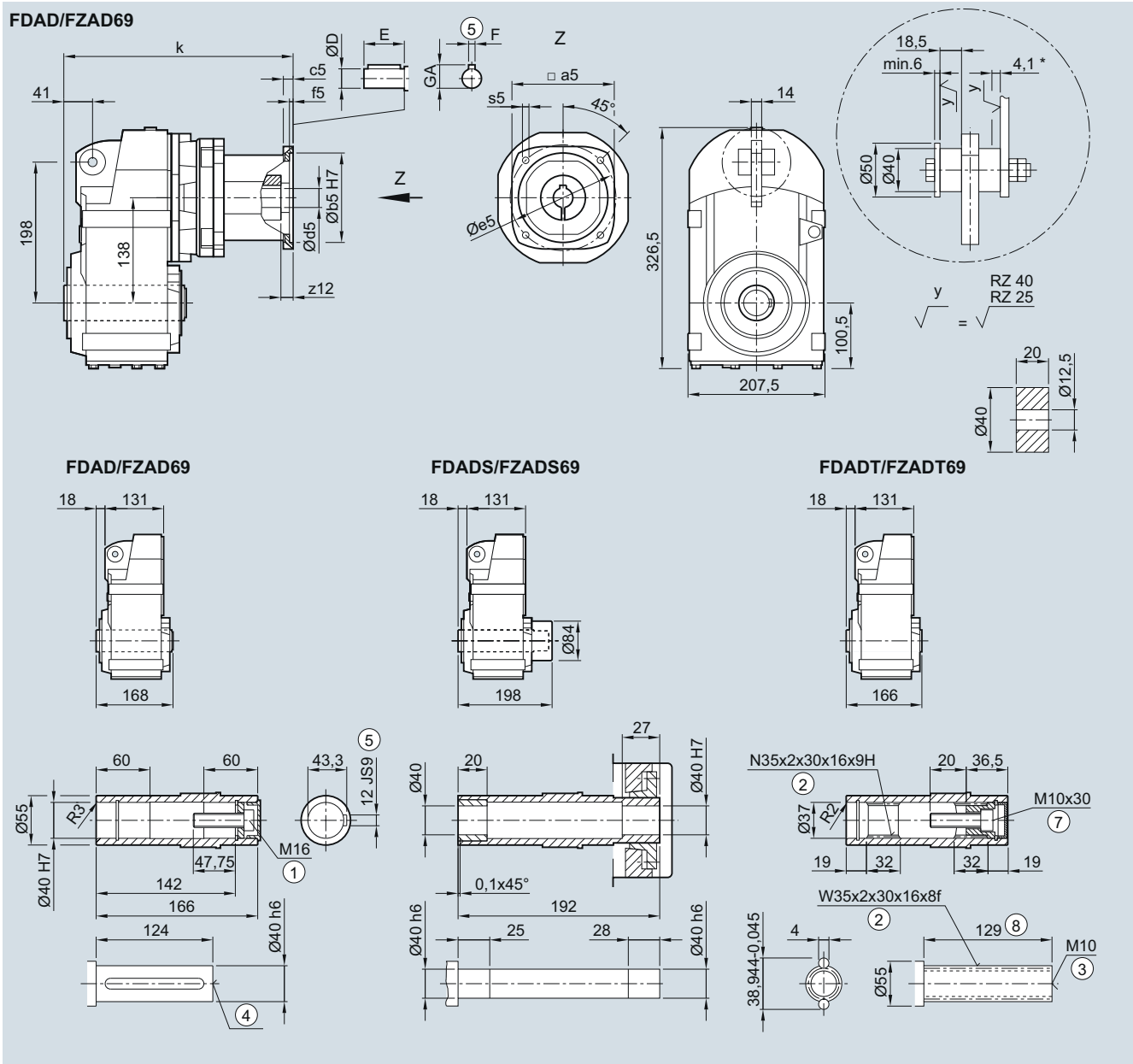

4

Adapter	a5	b5	c5	f5	e5	s5	z12	d5/D	E	F	GA	k
703	71.6	60	9	4.0	75	M5	18.0	14	30	5	16.0	239.0
704	96.5	80	10	4.0	100	M6	14.0	19	40	6	21.5	286.0
706	126.0	110	12	4.5	130	M8	15.0	24	50	8	27.0	299.0
708	155.0	130	15	4.5	165	M10	23.5	32	58	10	35.0	342.5
710	192.5	180	18	5.0	215	M12	33.0	38	80	10	41.0	411.5

① ISO 4014 ② DIN 5480 ③ DIN 332-D ④ DIN 332 ⑤ Feather key/keyway DIN 6885 ⑦ ISO 4762 ⑧ Without locating shoulder +1 mm

* Spring compression at max. torque

SIMOGEAR Gearboxes

Parallel shaft gearbox with adapter KQ

Dimensions

FD.Z./FZ.Z.69 gearbox in a housing flange design

FDZ030KQ, FAZ030KQ, FAZS030KQ, FAZT030KQ

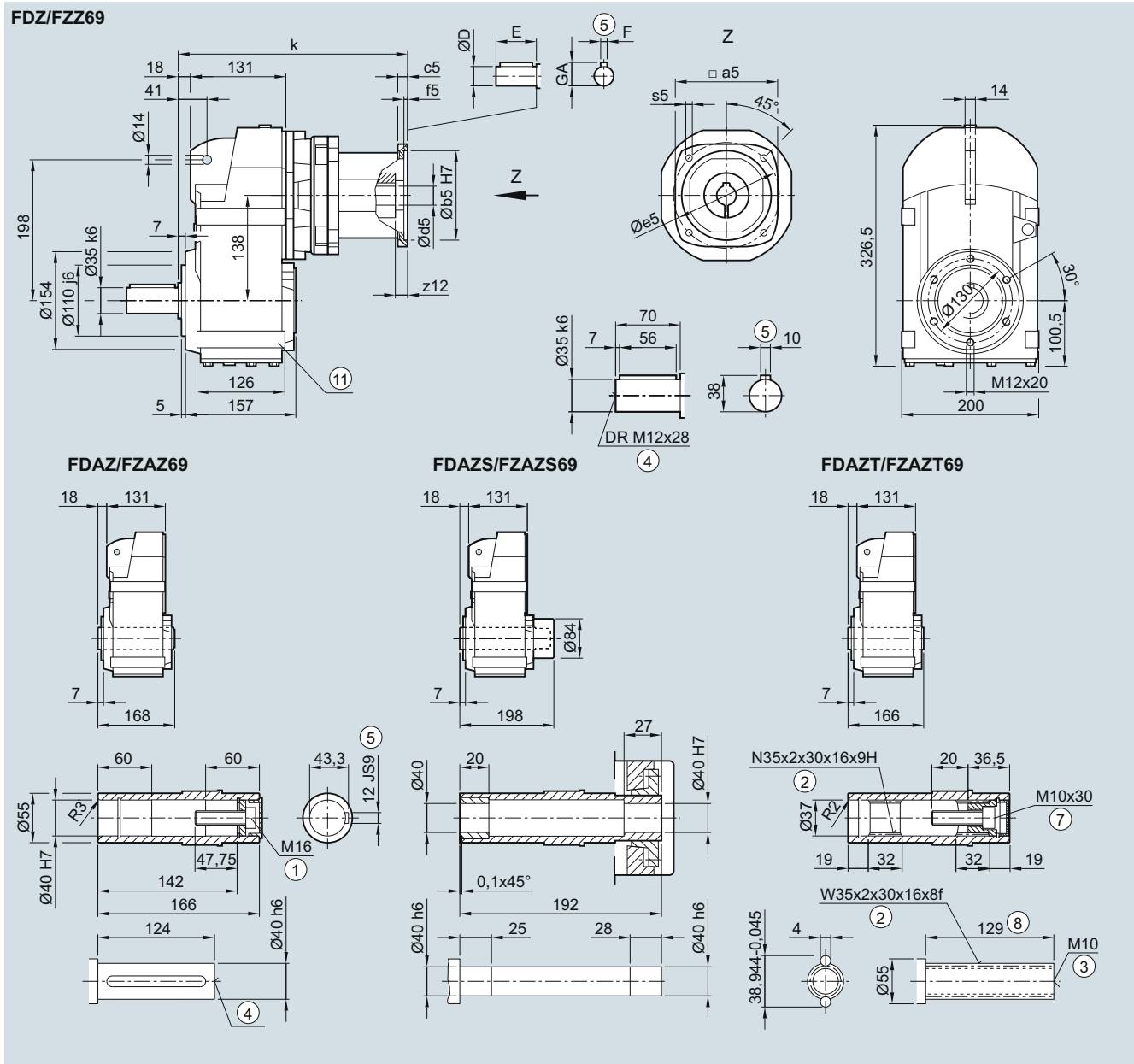

Adapter	a5	b5	c5	f5	e5	s5	z12	d5/D	E	F	GA	k
703	71.6	60	9	4.0	75	M5	18.0	14	30	5	16.0	239.0
704	96.5	80	10	4.0	100	M6	14.0	19	40	6	21.5	286.0
706	126.0	110	12	4.5	130	M8	15.0	24	50	8	27.0	299.0
708	155.0	130	15	4.5	165	M10	23.5	32	58	10	35.0	342.5
710	192.5	180	18	5.0	215	M12	33.0	38	80	10	41.0	411.5

- ① ISO 4014 ② DIN 5480 ③ DIN 332-D ④ DIN 332
 ⑤ Feather key/keyway DIN 6885 ⑦ ISO 4762 ⑧ Without locating shoulder +1 mm ⑩ Use bores only for foot-mounted design

SIMOGEAR Gearboxes

Parallel shaft gearbox with adapter KQ

Dimensions

FD.F./FZ.F.69 gearbox in a flange-mounted design

FF030KQ, FAF030KQ, FAFS030KQ, FAFT030KQ

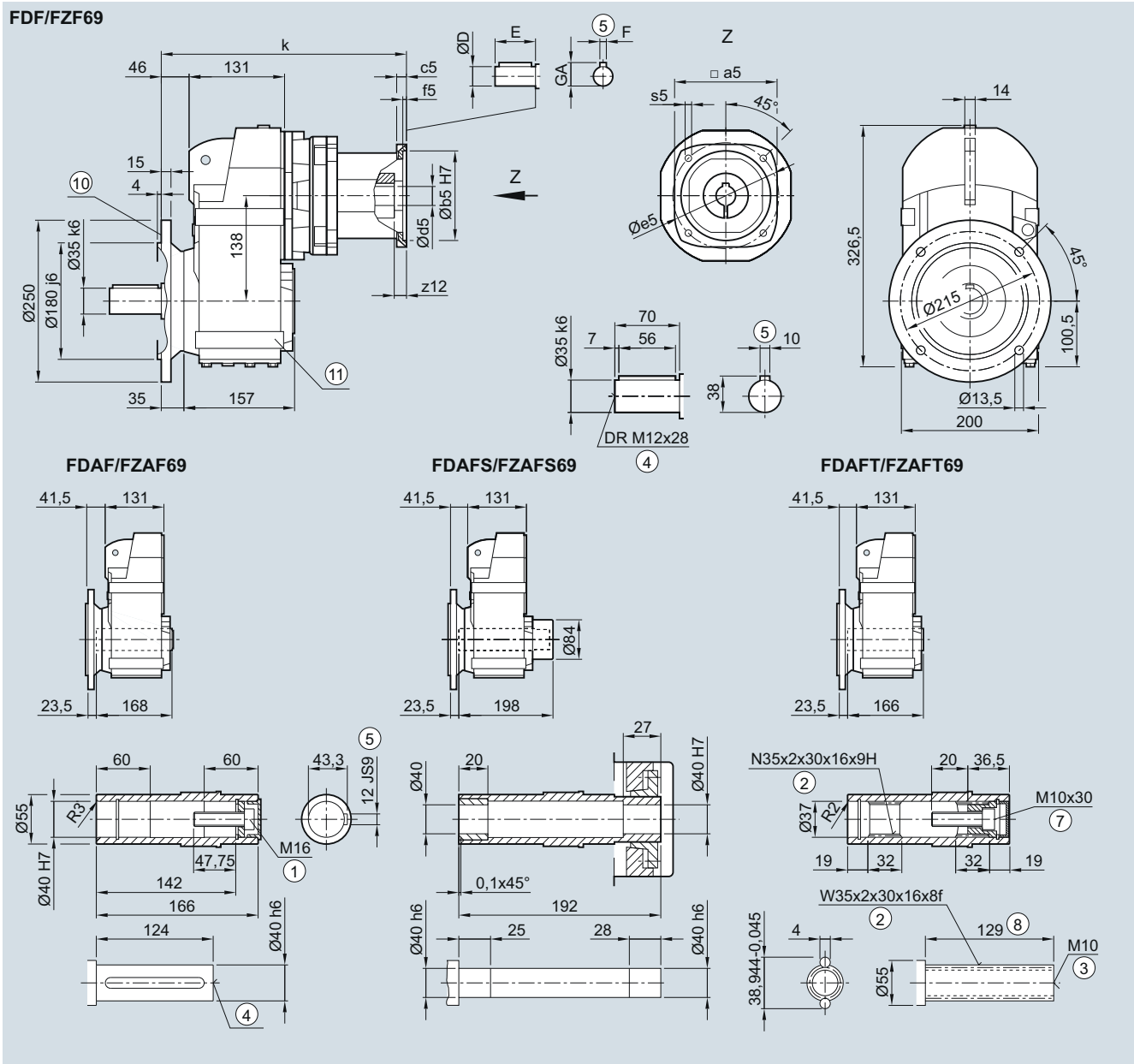

4

Adapter	a5	b5	c5	f5	e5	s5	z12	d5/D	E	F	GA	k
703	71.6	60	9	4.0	75	M5	18.0	14	30	5	16.0	267.0
704	96.5	80	10	4.0	100	M6	14.0	19	40	6	21.5	314.0
706	126.0	110	12	4.5	130	M8	15.0	24	50	8	27.0	327.0
708	155.0	130	15	4.5	165	M10	23.5	32	58	10	35.0	370.5
710	192.5	180	18	5.0	215	M12	33.0	38	80	10	41.0	439.5

① ISO 4014 ② DIN 5480 ③ DIN 332-D ④ DIN 332 ⑤ Feather key/keyway DIN 6885
 ⑦ ISO 4762 ⑥ Without locating shoulder +1 mm ⑩ For inner contour, see page 4/129 ⑪ Use bores only for foot-mounted design

SIMOGEAR Gearboxes

Parallel shaft gearbox with adapter KQ

Dimensions

FD../FZ..69 gearbox in a foot-mounted design

F030, KQ FA030KQ, FAS030KQ, FAT030KQ

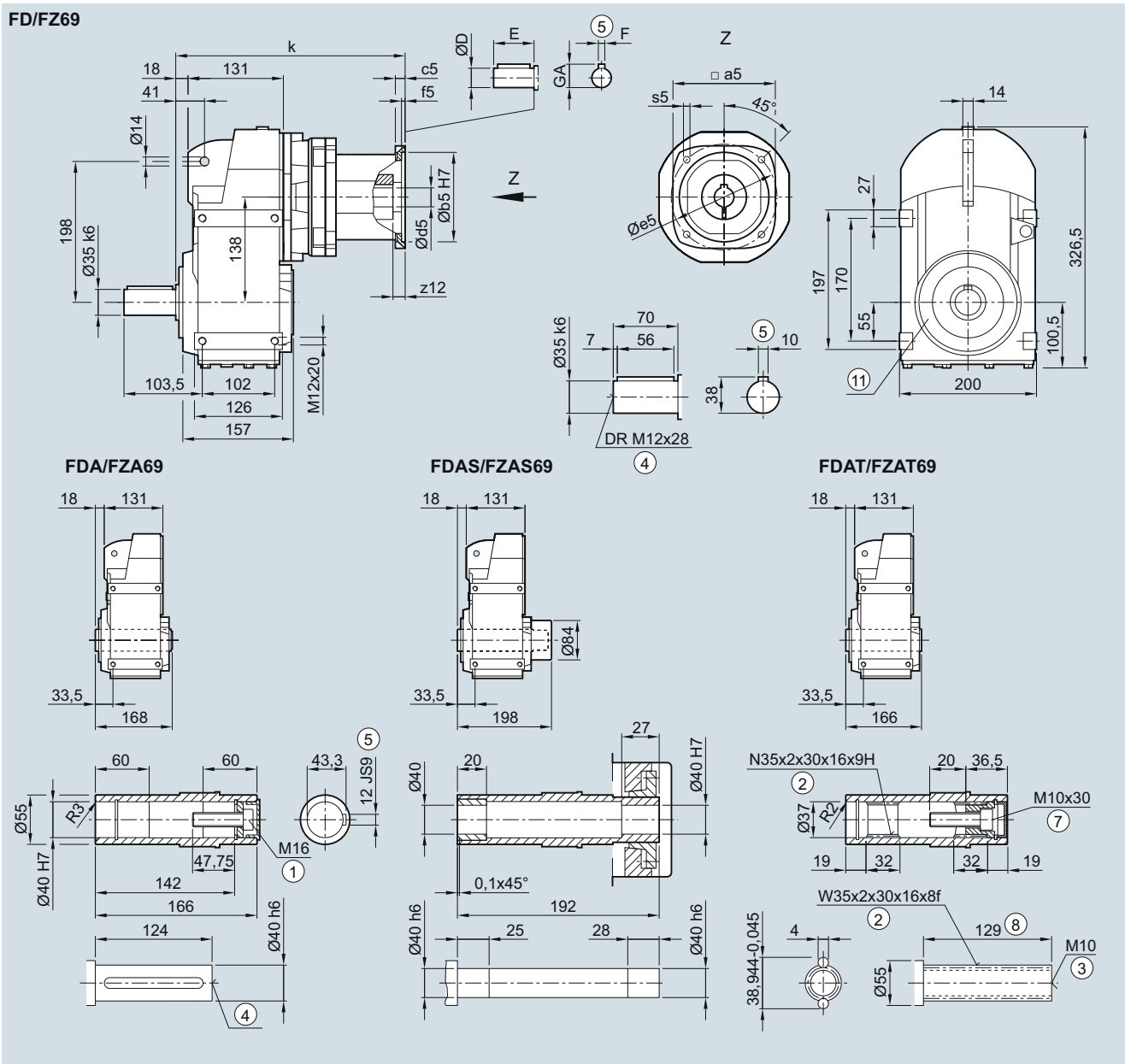

Adapter	a5	b5	c5	f5	e5	s5	z12	d5/D	E	F	GA	k
703	71.6	60	9	4.0	75	M5	18.0	14	30	5	16.0	239.0
704	96.5	80	10	4.0	100	M6	14.0	19	40	6	21.5	286.0
706	126.0	110	12	4.5	130	M8	15.0	24	50	8	27.0	299.0
708	155.0	130	15	4.5	165	M10	23.5	32	58	10	35.0	342.5
710	192.5	180	18	5.0	215	M12	33.0	38	80	10	41.0	411.5

- ① ISO 4014 ② DIN 5480 ③ DIN 332-D ④ DIN 332
- ⑤ Feather key/keyway DIN 6885 ⑦ ISO 4762 ⑧ Without locating shoulder +1 mm ⑩ Use bores only for housing flange design

FDAD./FZAD.79 gearbox in a shaft-mounted design

FAD030KQ, FADS030KQ, FADT030KQ

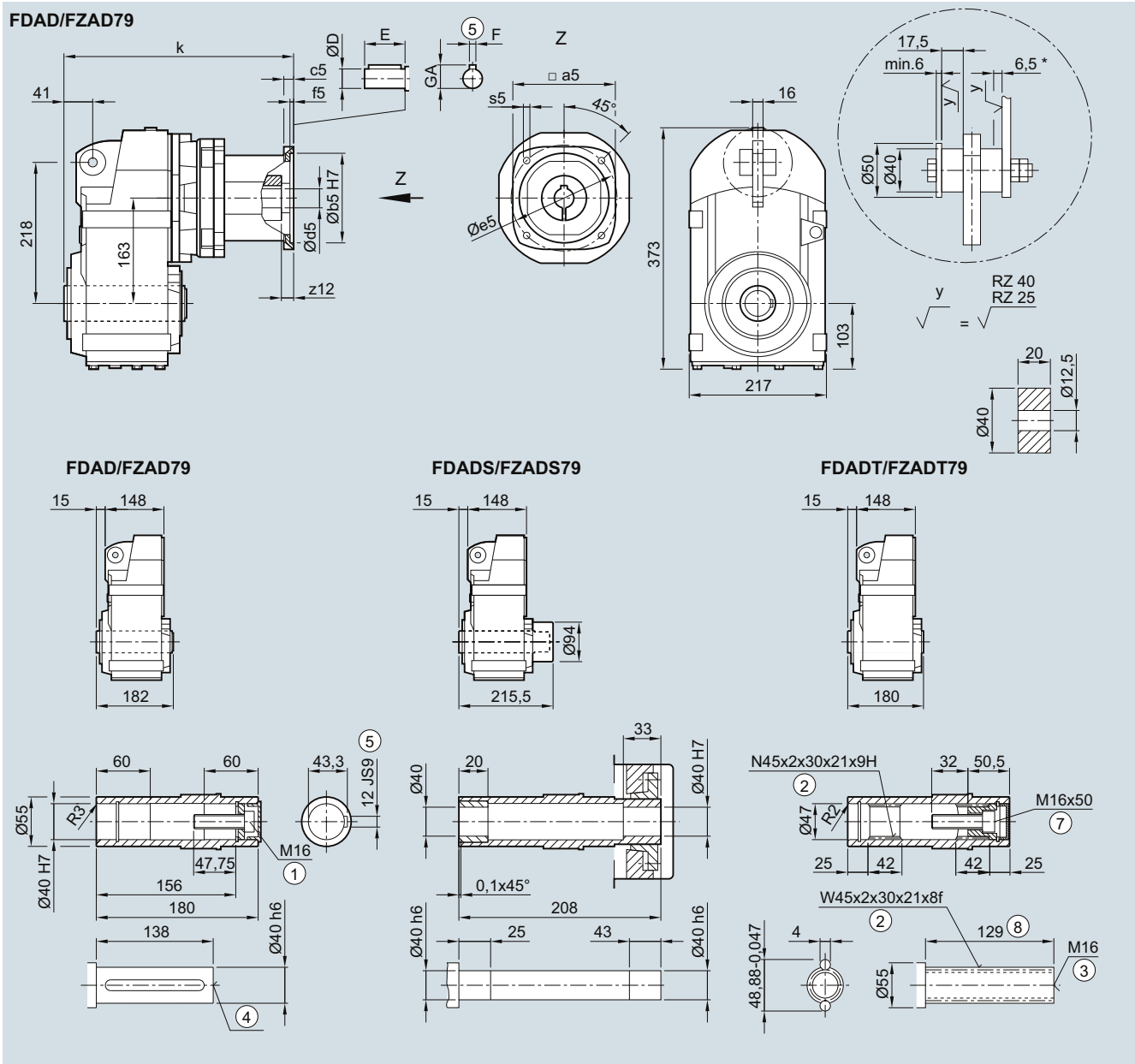

4

Adapter	a5	b5	c5	f5	e5	s5	z12	d5/D	E	F	GA	k
703	71.6	60	9	4.0	75	M5	18.0	14	30	5	16.0	251.0
704	96.5	80	10	4.0	100	M6	14.0	19	40	6	21.5	294.0
706	126.0	110	12	4.5	130	M8	15.0	24	50	8	27.0	307.0
708	155.0	130	15	4.5	165	M10	23.5	32	58	10	35.0	350.5
710	192.5	180	18	5.0	215	M12	33.0	38	80	10	41.0	419.5

① ISO 4014 ② DIN 5480 ③ DIN 332-D ④ DIN 332 ⑤ Feather key/keyway DIN 6885 ⑦ ISO 4762 ⑧ Without locating shoulder +1 mm

* Spring compression at max. torque

SIMOGEAR Gearboxes

Parallel shaft gearbox with adapter KQ

Dimensions

FD.Z./FZ.Z.79 gearbox in a housing flange design

FDZ030KQ, FAZ030KQ, FAZS030KQ, FAZT030KQ

FDZ/FZZ79

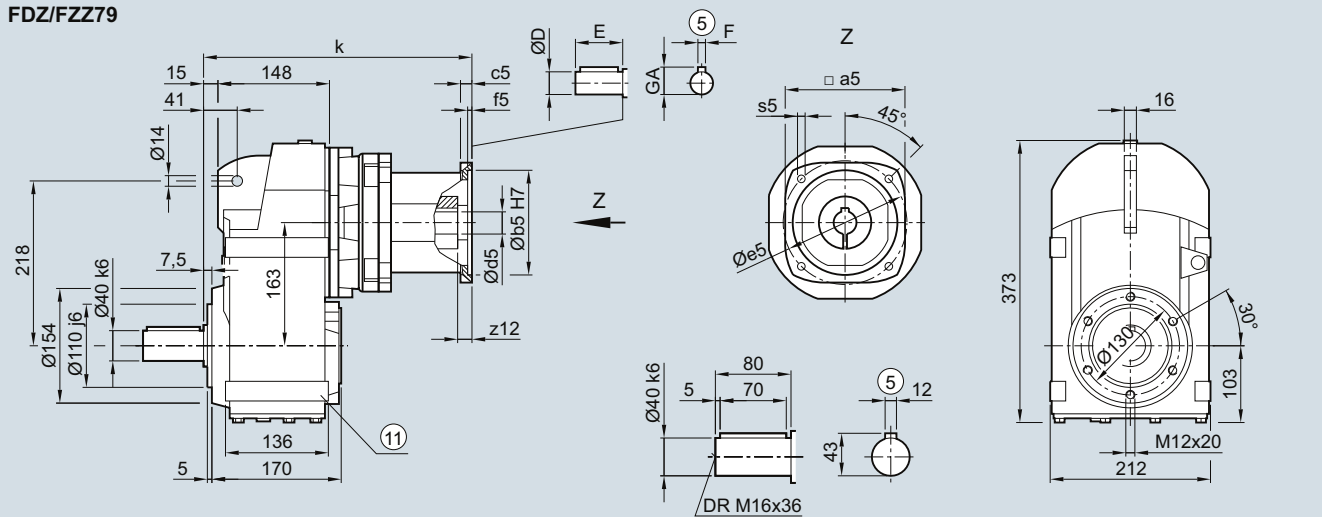

FDAZ/FAZ79

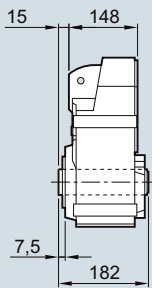

FDAZS/FAZS79

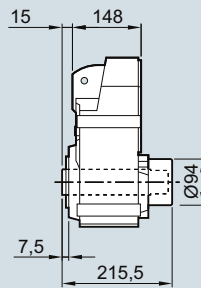

FDAZT/FAZT79

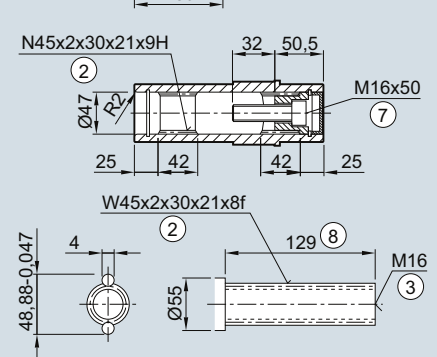
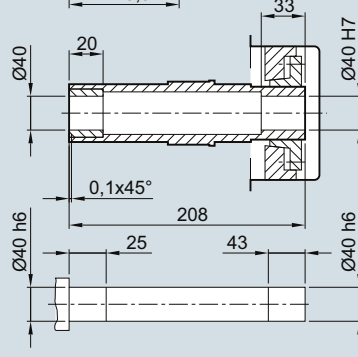
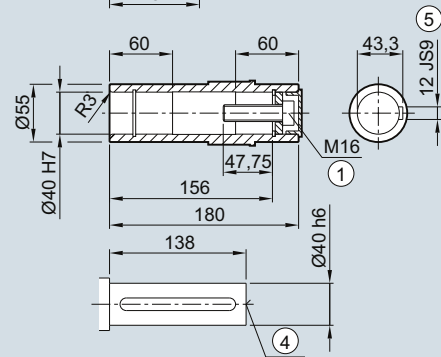
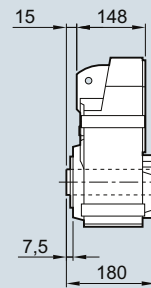

Adapter	a5	b5	c5	f5	e5	s5	z12	d5/D	E	F	GA	k
703	71.6	60	9	4.0	75	M5	18.0	14	30	5	16.0	251.0
704	96.5	80	10	4.0	100	M6	14.0	19	40	6	21.5	294.0
706	126.0	110	12	4.5	130	M8	15.0	24	50	8	27.0	307.0
708	155.0	130	15	4.5	165	M10	23.5	32	58	10	35.0	350.5
710	192.5	180	18	5.0	215	M12	33.0	38	80	10	41.0	419.5

① ISO 4014

② DIN 5480

③ DIN 332-D

④ DIN 332

⑤ Feather key/keyway DIN 6885

⑦ ISO 4762

⑧ Without locating shoulder +1 mm

⑩ Use bores only for foot-mounted design

FD.F./FZ.F.79 gearbox in a flange-mounted design

FF030KQ, FAF030KQ, FAFS030KQ, FAFT030KQ

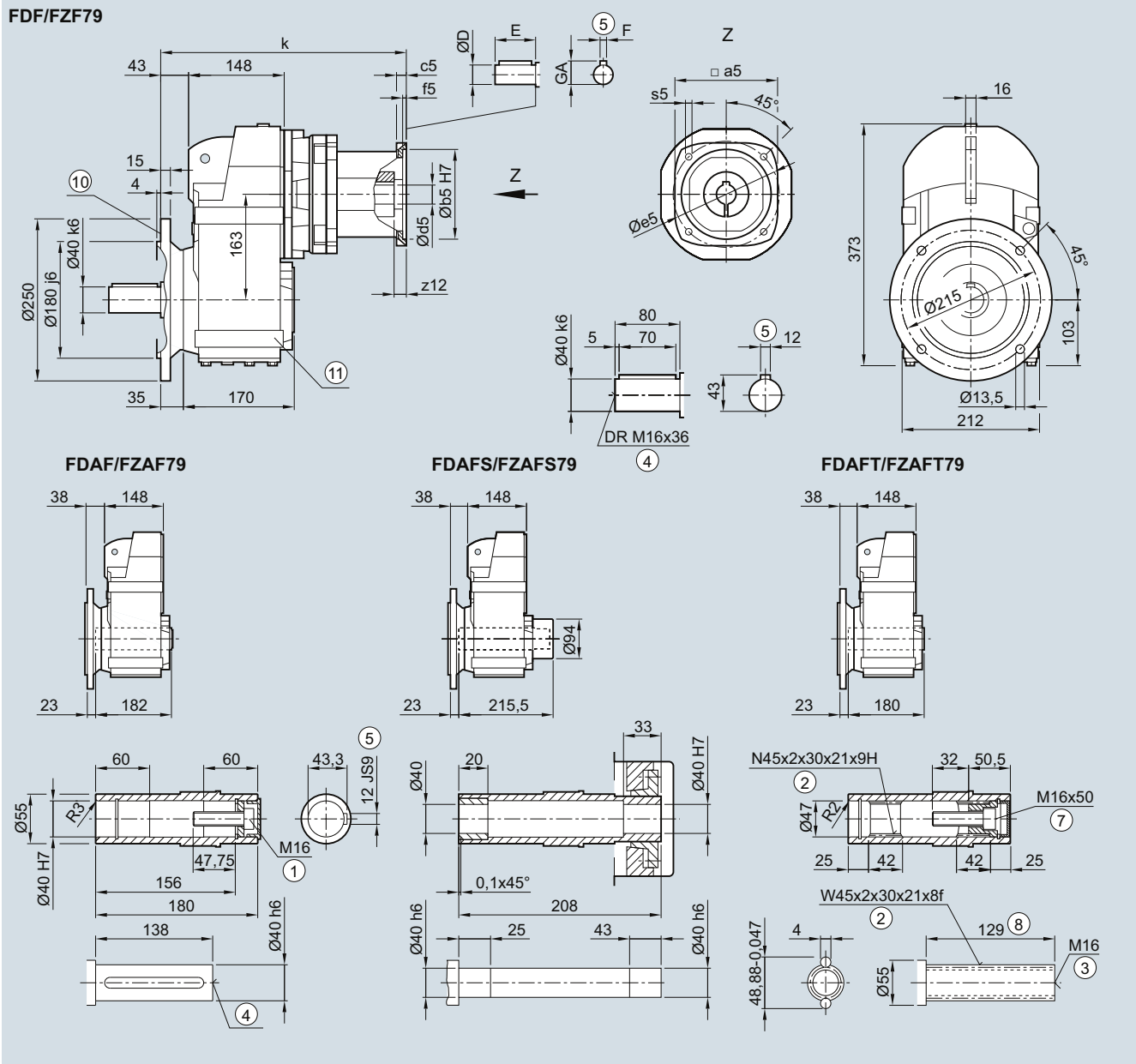

4

Adapter	a5	b5	c5	f5	e5	s5	z12	d5/D	E	F	GA	k
703	71.6	60	9	4.0	75	M5	18.0	14	30	5	16.0	279.0
704	96.5	80	10	4.0	100	M6	14.0	19	40	6	21.5	322.0
706	126.0	110	12	4.5	130	M8	15.0	24	50	8	27.0	335.0
708	155.0	130	15	4.5	165	M10	23.5	32	58	10	35.0	378.5
710	192.5	180	18	5.0	215	M12	33.0	38	80	10	41.0	447.5

① ISO 4014 ② DIN 5480 ③ DIN 332-D ④ DIN 332 ⑤ Feather key/keyway DIN 6885
 ⑦ ISO 4762 ⑥ Without locating shoulder +1 mm ⑩ For inner contour, see page 4/129 ⑧ Use bores only for foot-mounted design

SIMOGEAR Gearboxes

Parallel shaft gearbox with adapter KQ

Dimensions

FD../FZ..79 gearbox in a foot-mounted design

F030KQ, FA030KQ, FAS030KQ, FAT030KQ

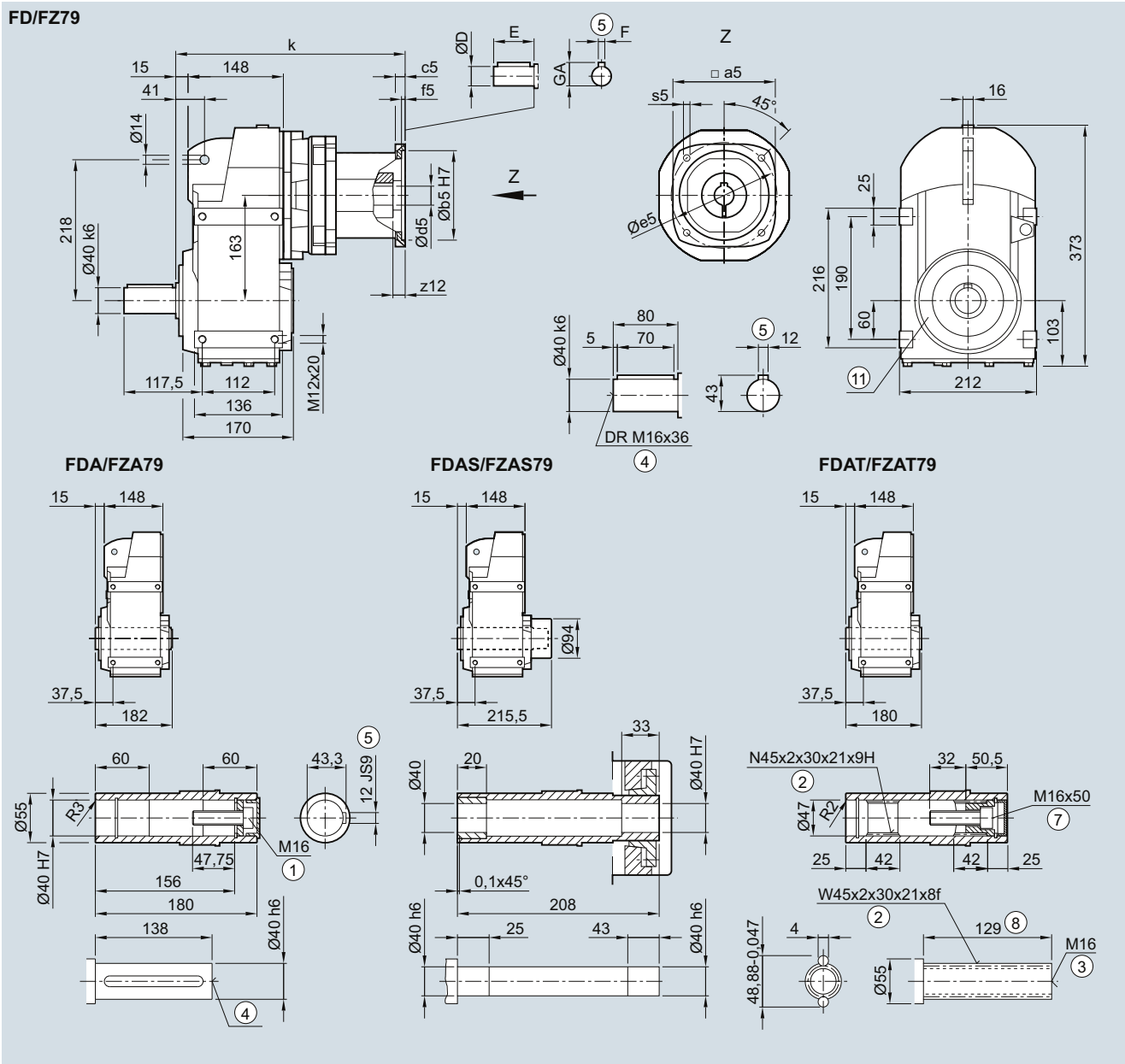

Adapter	a5	b5	c5	f5	e5	s5	z12	d5/D	E	F	GA	k
703	71.6	60	9	4.0	75	M5	18.0	14	30	5	16.0	251.0
704	96.5	80	10	4.0	100	M6	14.0	19	40	6	21.5	294.0
706	126.0	110	12	4.5	130	M8	15.0	24	50	8	27.0	307.0
708	155.0	130	15	4.5	165	M10	23.5	32	58	10	35.0	350.5
710	192.5	180	18	5.0	215	M12	33.0	38	80	10	41.0	419.5

- ① ISO 4014 ② DIN 5480 ③ DIN 332-D ④ DIN 332
- ⑤ Feather key/keyway DIN 6885 ⑦ ISO 4762 ⑧ Without locating shoulder +1 mm ⑩ Use bores only for housing flange design

FDAD./FZAD.89 gearbox in a shaft-mounted design

FAD030KQ, FADS030KQ, FADT030KQ

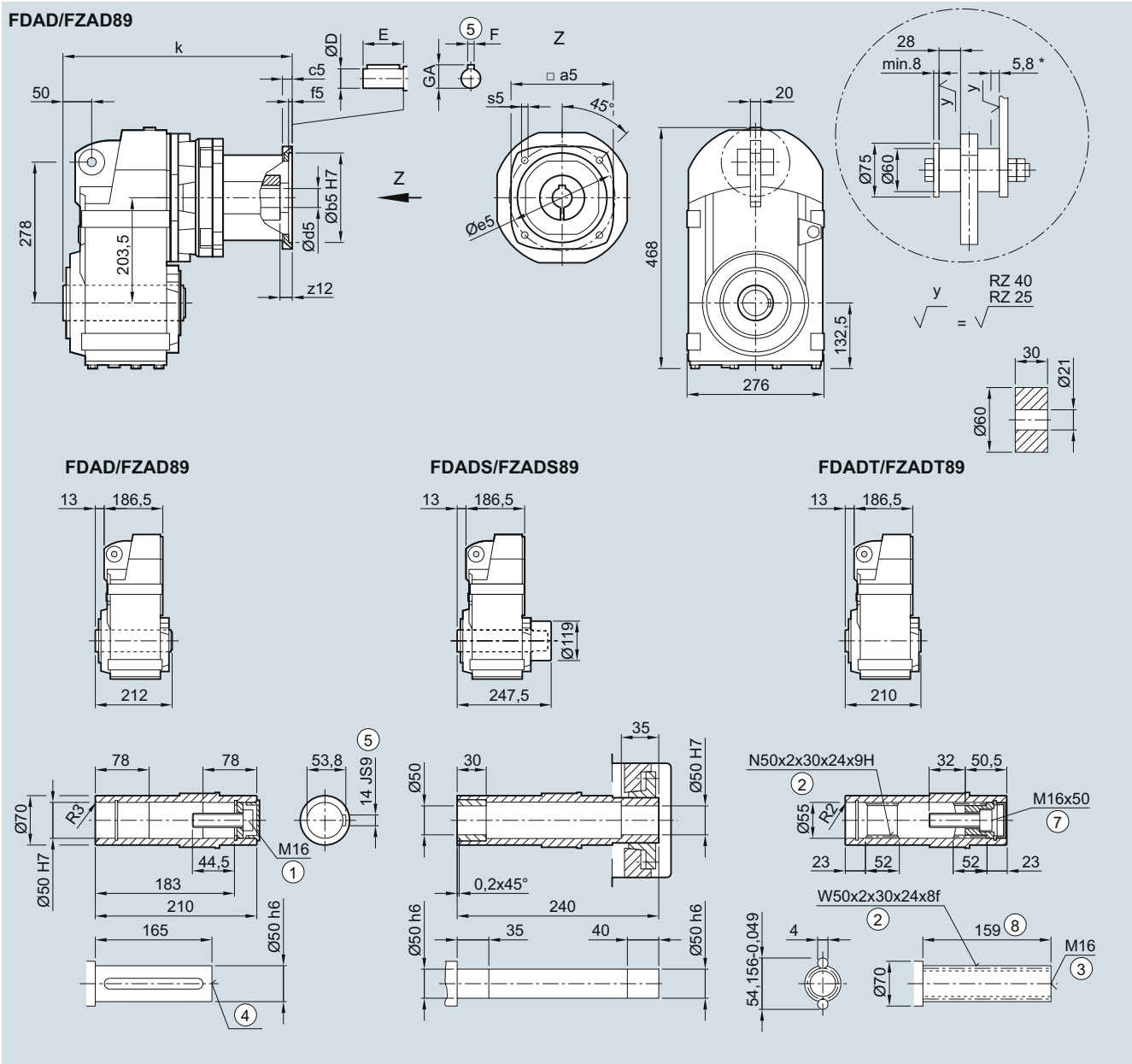

4

Adapter	a5	b5	c5	f5	e5	s5	z12	d5/D	E	F	GA	k
704	96.5	80	10	4.0	100	M6	14.0	19	40	6	21.5	317.5
706	126.0	110	12	4.5	130	M8	15.0	24	50	8	27.0	330.5
708	155.0	130	15	4.5	165	M10	23.5	32	58	10	35.0	370.0
710	192.5	180	18	5.0	215	M12	33.0	38	80	10	41.0	439.0

① ISO 4014 ② DIN 5480 ③ DIN 332-D ④ DIN 332 ⑤ Feather key/keyway DIN 6885 ⑦ ISO 4762 ⑥ Without locating shoulder +1 mm

SIMOGEAR Gearboxes

Parallel shaft gearbox with adapter KQ

Dimensions

FD.Z./FZ.Z.89 gearbox in a housing flange design

FDZ030KQ, FAZ030KQ, FAZS030KQ, FAZT030KQ

FDZ/FZZ89

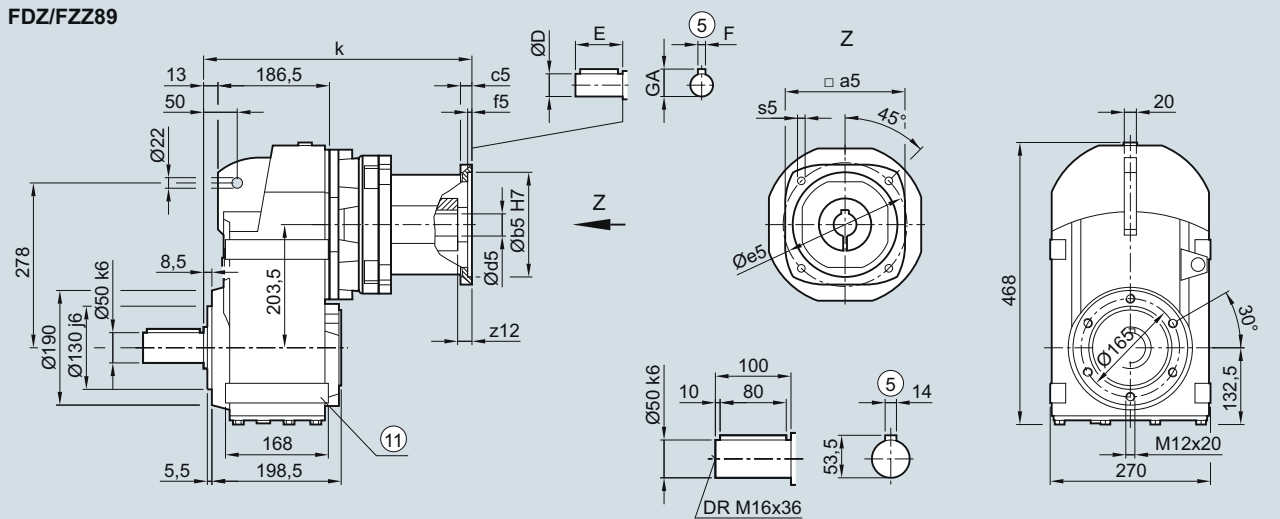

FDAZ/FZAZ89

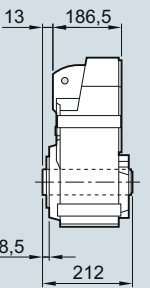

FDAZS/FZAZS89

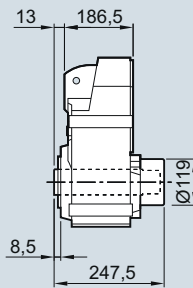

FDAZT/FZAZT89

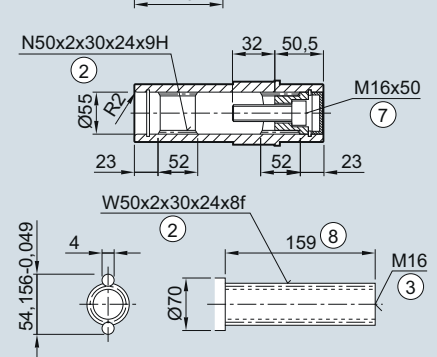
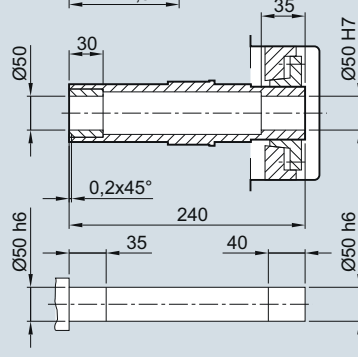
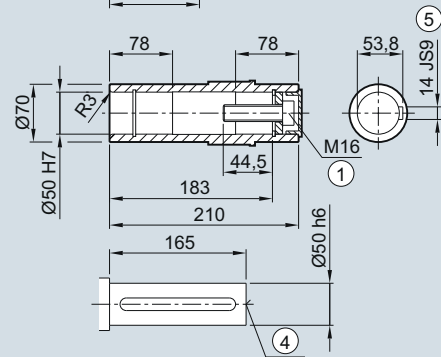
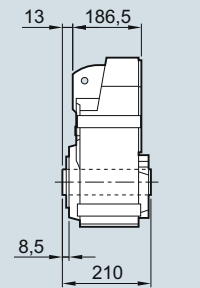

Adapter	a5	b5	c5	f5	e5	s5	z12	d5/D	E	F	GA	k
704	96.5	80	10	4.0	100	M6	14.0	19	40	6	21.5	317.5
706	126.0	110	12	4.5	130	M8	15.0	24	50	8	27.0	330.5
708	155.0	130	15	4.5	165	M10	23.5	32	58	10	35.0	370.0
710	192.5	180	18	5.0	215	M12	33.0	38	80	10	41.0	439.0

① ISO 4014

② DIN 5480

③ DIN 332-D

④ DIN 332

⑤ Feather key/keyway DIN 6885

⑦ ISO 4762

⑧ Without locating shoulder +1 mm

⑩ Use bores only for foot-mounted design

FD.F./FZ.F.89 gearbox in a flange-mounted design

FF030KQ, FAF030KQ, FAFS030KQ, FAFT030KQ

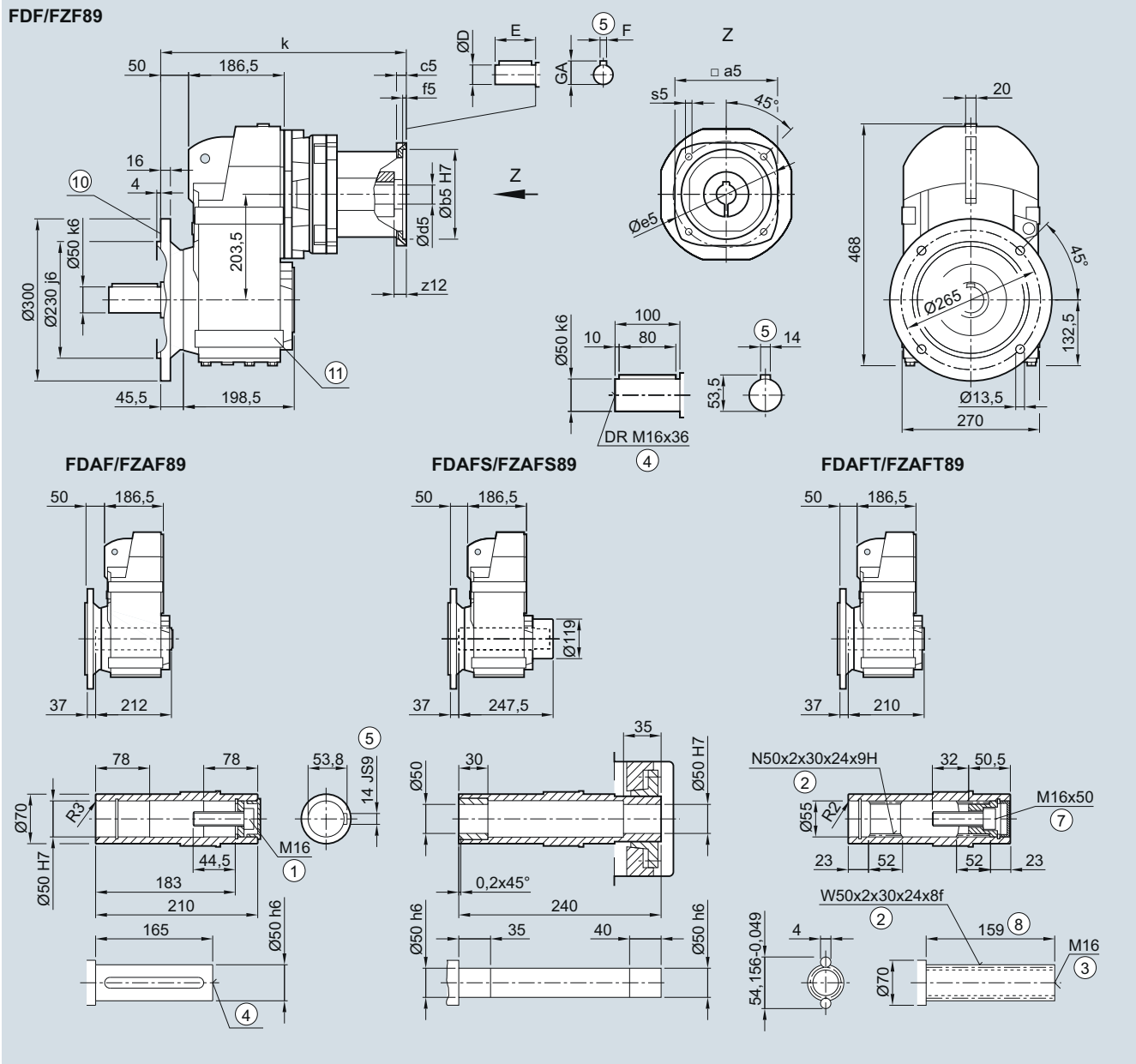

4

Adapter	a5	b5	c5	f5	e5	s5	z12	d5/D	E	F	GA	k
704	96.5	80	10	4.0	100	M6	14.0	19	40	6	21.5	354.5
706	126.0	110	12	4.5	130	M8	15.0	24	50	8	27.0	367.5
708	155.0	130	15	4.5	165	M10	23.5	32	58	10	35.0	407.0
710	192.5	180	18	5.0	215	M12	33.0	38	80	10	41.0	476.0

- ① ISO 4014 ② DIN 5480 ③ DIN 332-D ④ DIN 332 ⑤ Feather key/keyway DIN 6885
- ⑦ ISO 4762 ⑥ Without locating shoulder +1 mm ⑩ For inner contour, see page 4/129 ⑧ Use bores only for foot-mounted design

SIMOGEAR Gearboxes

Parallel shaft gearbox with adapter KQ

Dimensions

FD../FZ..89 gearbox in a foot-mounted design

F030KQ, FA030KQ, FAS030KQ, FAT030KQ

FD/FZ89

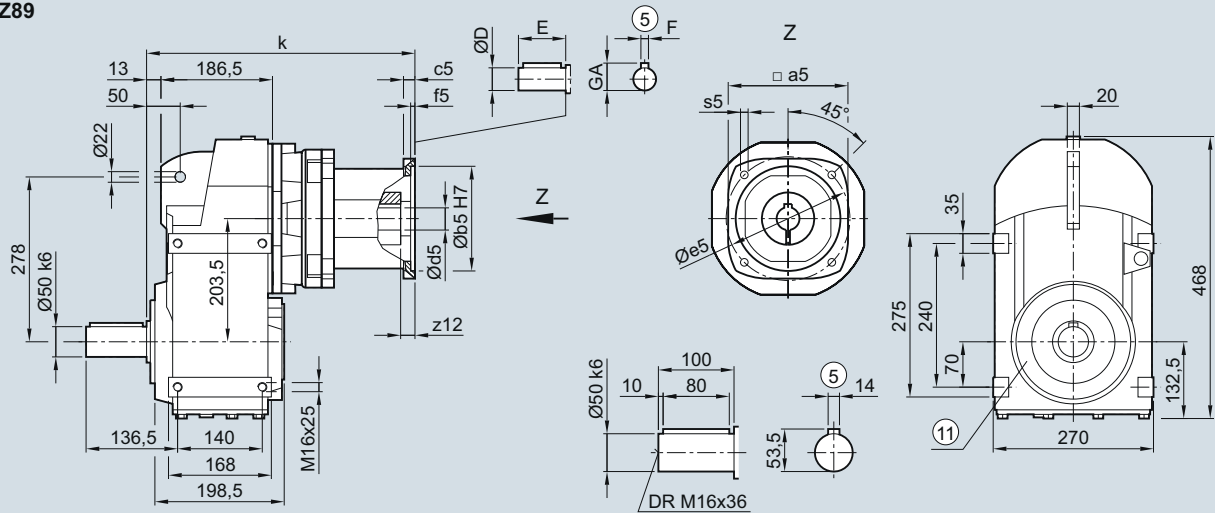

FDA/FZA89

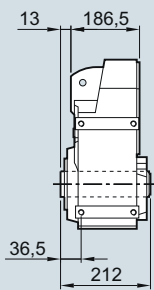

FDAS/FZAS89

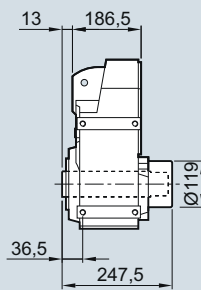

FDAT/FZAT89

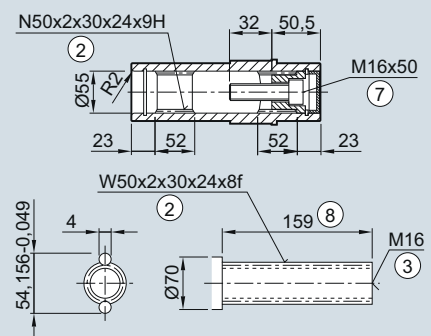
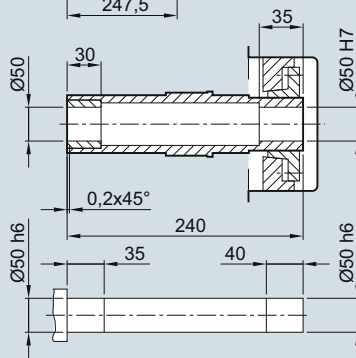
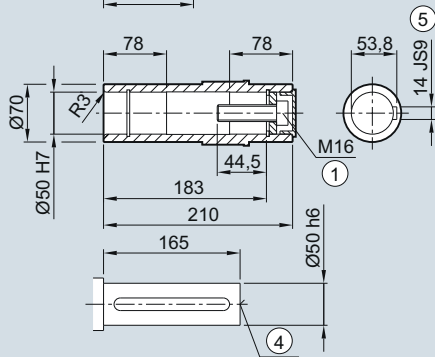
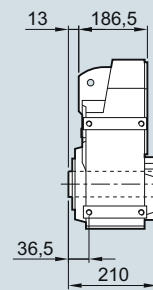

Adapter	a5	b5	c5	f5	e5	s5	z12	d5/D	E	F	GA	k
704	96.5	80	10	4.0	100	M6	14.0	19	40	6	21.5	317.5
706	126.0	110	12	4.5	130	M8	15.0	24	50	8	27.0	330.5
708	155.0	130	15	4.5	165	M10	23.5	32	58	10	35.0	370.0
710	192.5	180	18	5.0	215	M12	33.0	38	80	10	41.0	439.0

① ISO 4014

② DIN 5480

③ DIN 332-D

④ DIN 332

⑤ Feather key/keyway DIN 6885

⑦ ISO 4762

⑧ Without locating shoulder +1 mm

⑩ Use bores only for housing flange design

FDAD./FZAD.109 gearbox in a shaft-mounted design

FAD030KQ, FADS030KQ, FADT030KQ

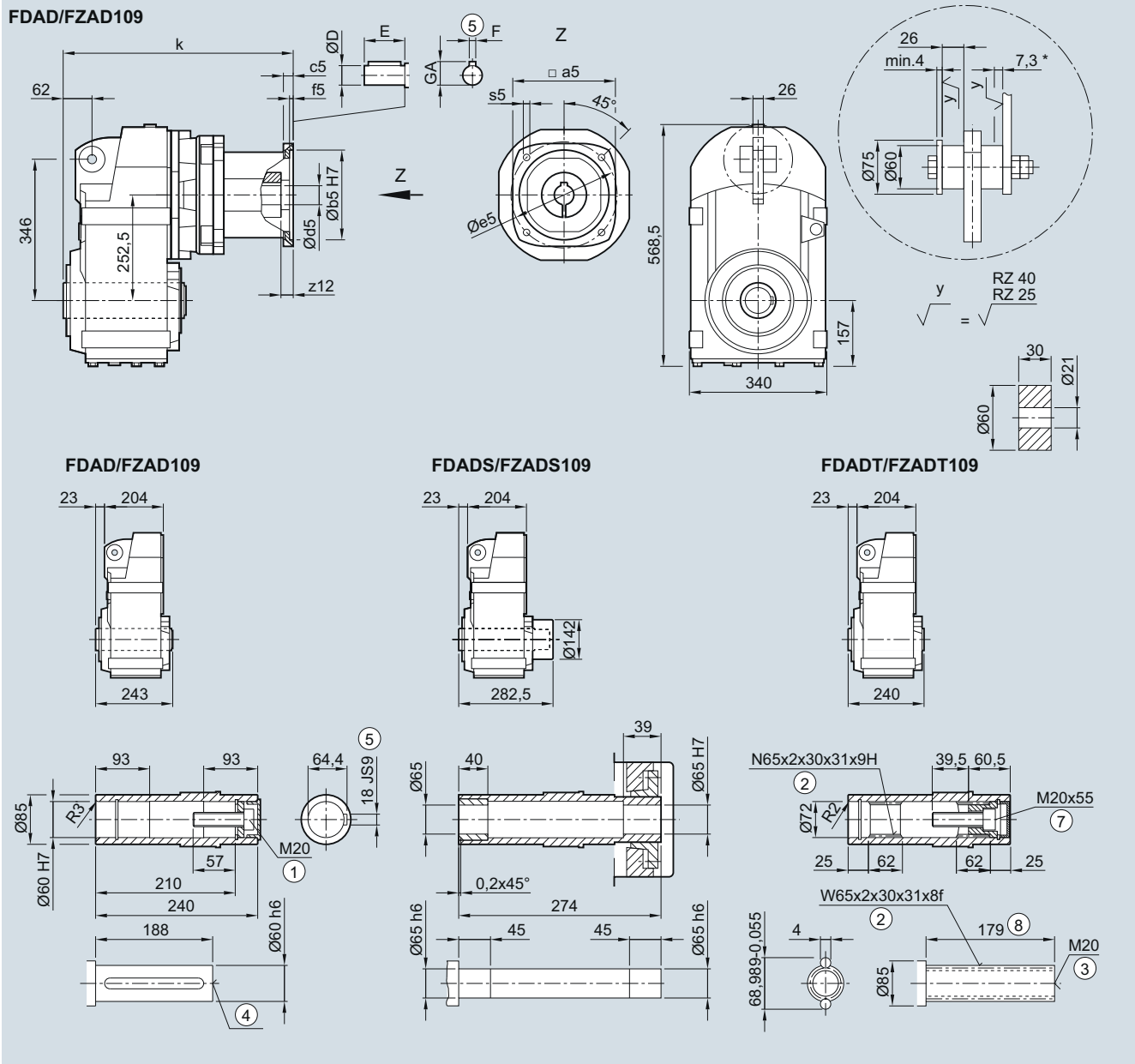

4

Adapter	a5	b5	c5	f5	e5	s5	z12	d5/D	E	F	GA	k
706	126.0	110	12	4.5	130	M8	15.0	24	50	8	27.0	351.0
708	155.0	130	15	4.5	165	M10	23.5	32	58	10	35.0	388.5
710	192.5	180	18	5.0	215	M12	33.0	38	80	10	41.0	457.5

① ISO 4014 ② DIN 5480 ③ DIN 332-D ④ DIN 332 ⑤ Feather key/keyway DIN 6885 ⑦ ISO 4762 ⑧ Without locating shoulder +1 mm

SIMOGEAR Gearboxes

Parallel shaft gearbox with adapter KQ

Dimensions

FD.Z./FZ.Z.109 gearbox in a housing flange design

FDZ030KQ, FAZ030KQ, FAZS030KQ, FAZT030KQ

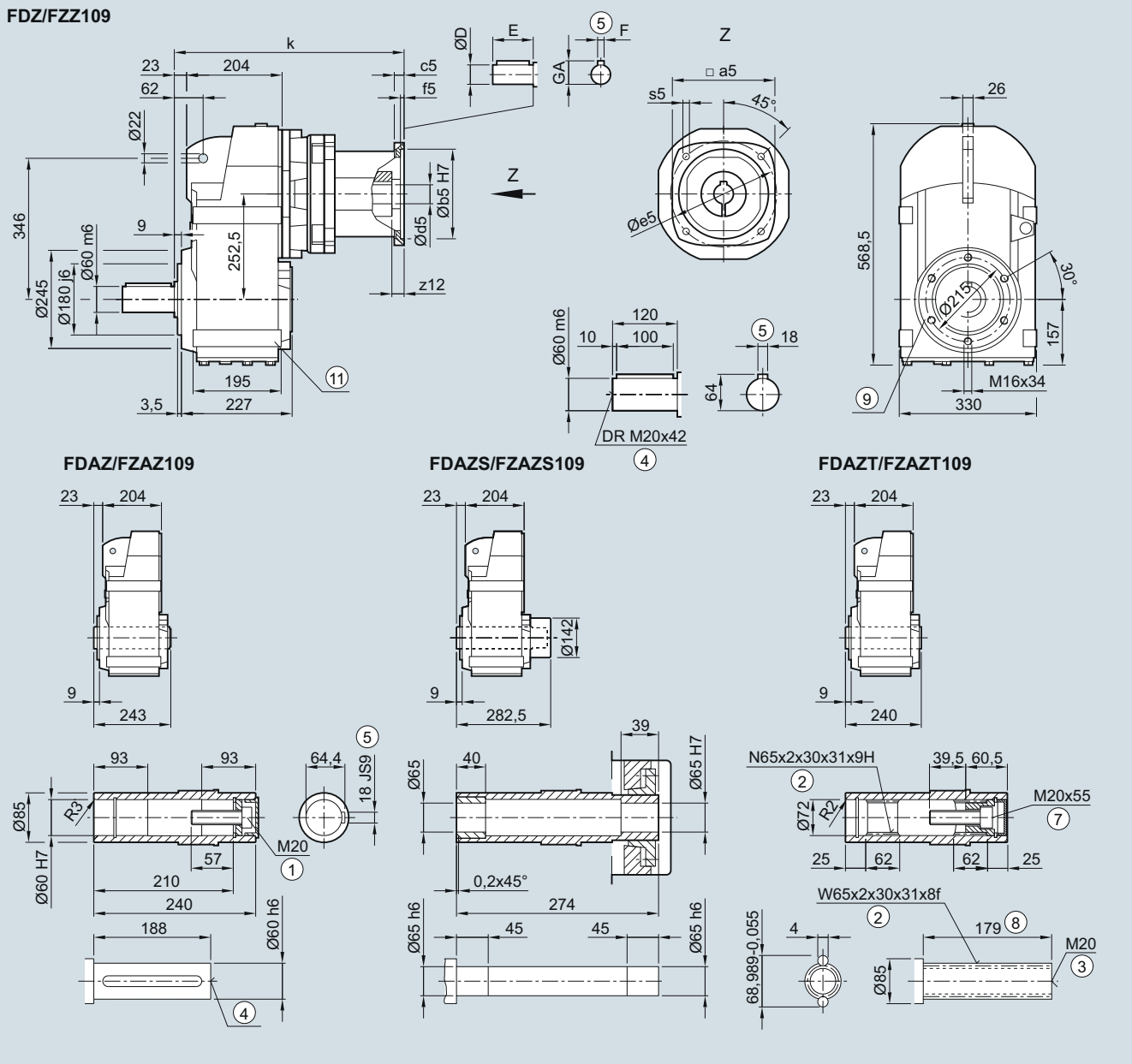

Adapter	a5	b5	c5	f5	e5	s5	z12	d5/D	E	F	GA	k
706	126.0	110	12	4.5	130	M8	15.0	24	50	8	27.0	351.0
708	155.0	130	15	4.5	165	M10	23.5	32	58	10	35.0	388.5
710	192.5	180	18	5.0	215	M12	33.0	38	80	10	41.0	457.5

- ① ISO 4014 ② DIN 5480 ③ DIN 332-D ④ DIN 332 ⑤ Feather key/keyway DIN 6885
- ⑦ ISO 4762 ⑥ Without locating shoulder +1 mm ⑨ For pin holes, see 4/131 ⑩ Use bores only for foot-mounted design

FD.F./FZ.F.109 gearbox in a flange-mounted design

FF030KQ, FAF030KQ, FAFS030KQ, FAFT030KQ

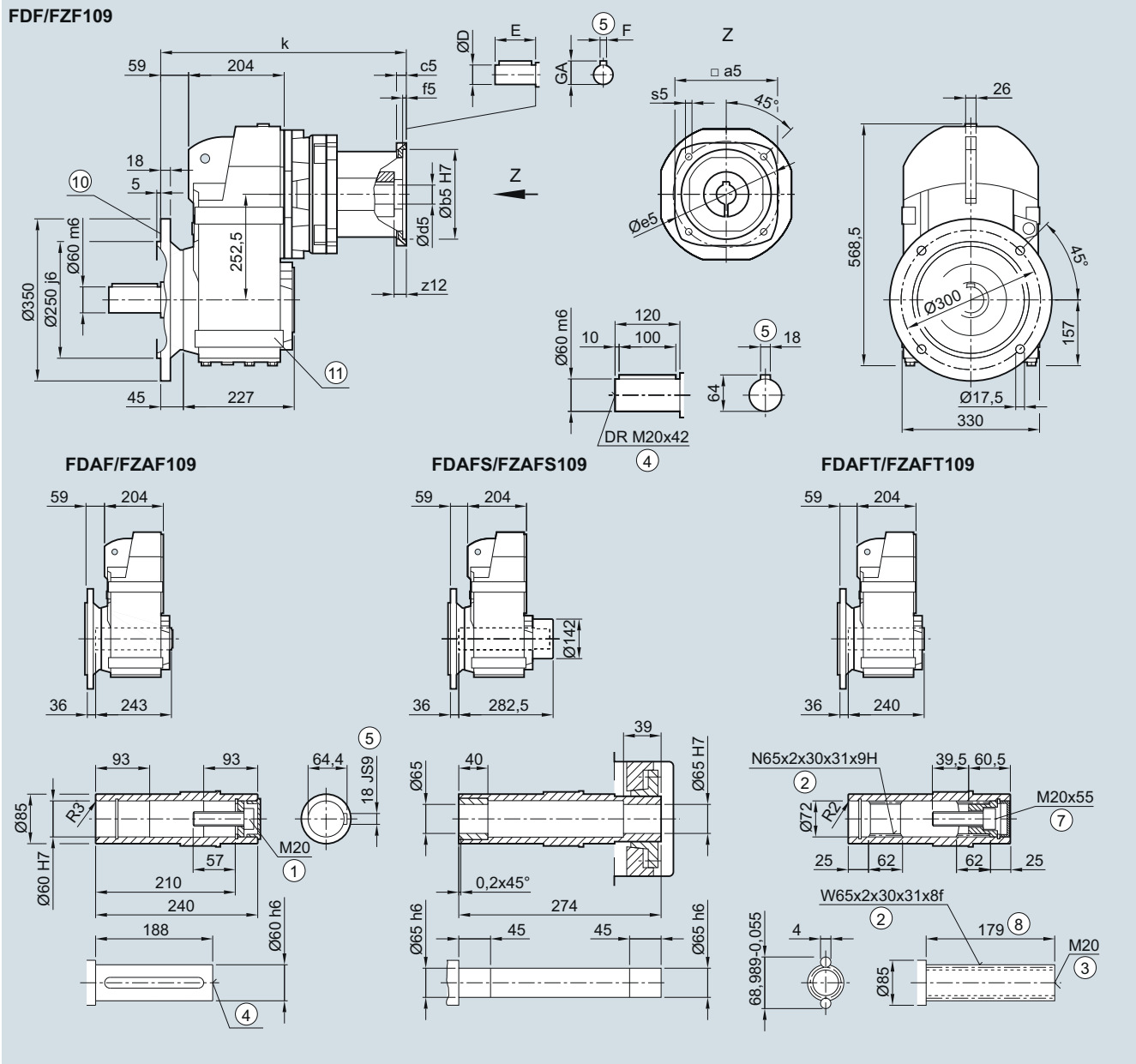

4

Adapter	a5	b5	c5	f5	e5	s5	z12	d5/D	E	F	GA	k
706	126.0	110	12	4.5	130	M8	15.0	24	50	8	27.0	387.0
708	155.0	130	15	4.5	165	M10	23.5	32	58	10	35.0	424.5
710	192.5	180	18	5.0	215	M12	33.0	38	80	10	41.0	493.5

- ① ISO 4014 ② DIN 5480 ③ DIN 332-D ④ DIN 332 ⑤ Feather key/keyway DIN 6885
- ⑦ ISO 4762 ⑥ Without locating shoulder +1 mm ⑩ For inner contour, see page 4/129 ⑪ Use bores only for foot-mounted design

SIMOGEAR Gearboxes

Parallel shaft gearbox with adapter KQ

Dimensions

FD../FZ..109 gearbox in a foot-mounted design

F030KQ, FA030KQ, FAS030KQ, FAT030KQ

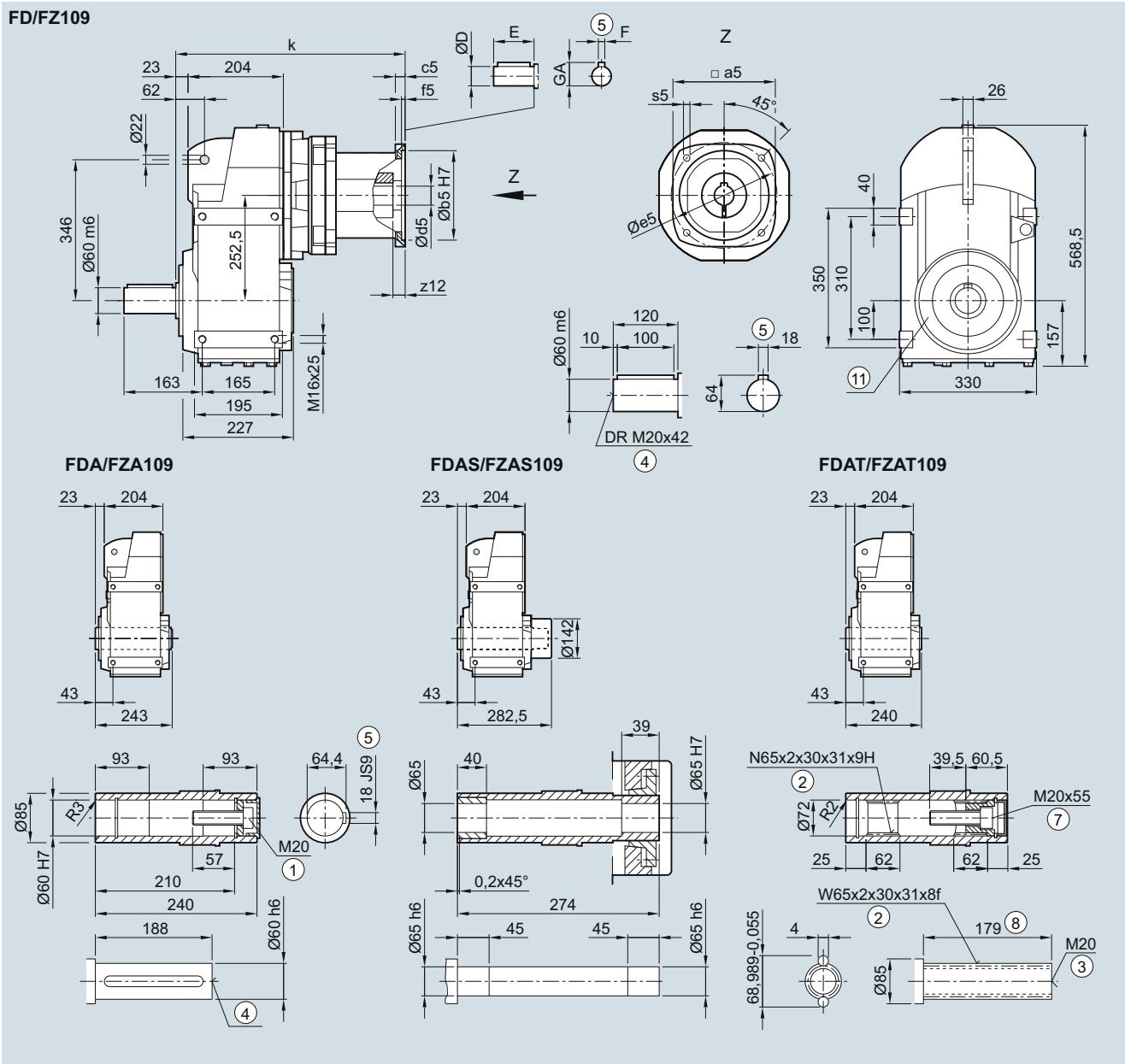

Adapter	a5	b5	c5	f5	e5	s5	z12	d5/D	E	F	GA	k
706	126.0	110	12	4.5	130	M8	15.0	24	50	8	27.0	351.0
708	155.0	130	15	4.5	165	M10	23.5	32	58	10	35.0	388.5
710	192.5	180	18	5.0	215	M12	33.0	38	80	10	41.0	457.5

- ① ISO 4014 ② DIN 5480 ③ DIN 332-D ④ DIN 332
- ⑤ Feather key/keyway DIN 6885 ⑦ ISO 4762 ⑧ Without locating shoulder +1 mm ⑩ Use bores only for housing flange design

FDAD./FZAD.129 gearbox in a shaft-mounted design

FAD030KQ, FADS030KQ, FADT030KQ

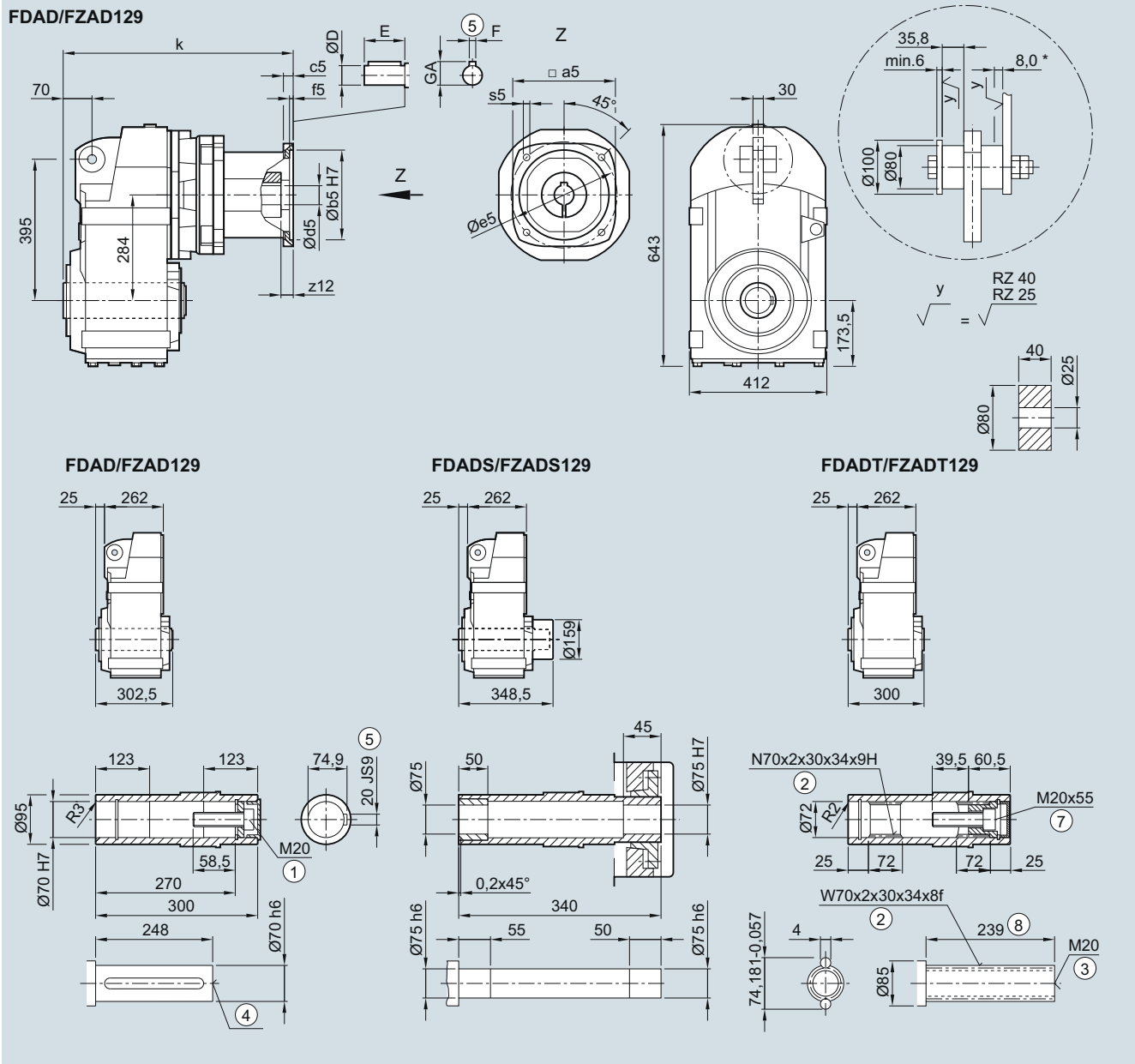

4

Adapter	a5	b5	c5	f5	e5	s5	z12	d5/D	E	F	GA	k
706	126.0	110	12	4.5	130	M8	15.0	24	50	8	27.0	404.0
708	155.0	130	15	4.5	165	M10	23.5	32	58	10	35.0	439.5
710	192.5	180	18	5.0	215	M12	33.0	38	80	10	41.0	506.5

① ISO 4014 ② DIN 5480 ③ DIN 332-D ④ DIN 332 ⑤ Feather key/keyway DIN 6885 ⑦ ISO 4762 ⑧ Without locating shoulder +1 mm

SIMOGEAR Gearboxes

Parallel shaft gearbox with adapter KQ

Dimensions

FD.Z./FZ.Z.129 gearbox in a housing flange design

FDZ030KQ, FAZ030KQ, FAZS030KQ, FAZT030KQ

FDZ/FZZ129

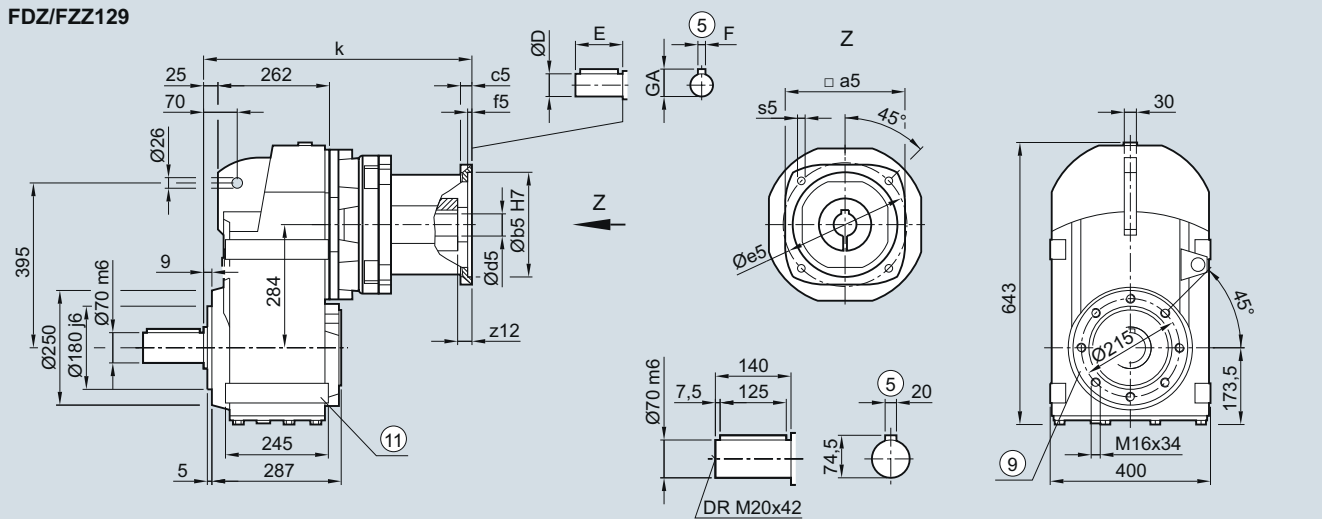

FDAZ/FAZ129

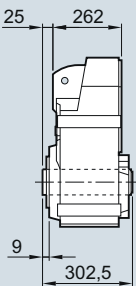

FDAZS/FAZS129

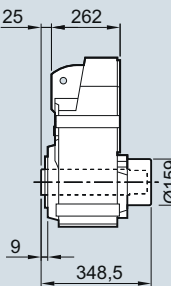

FDAZT/FAZT129

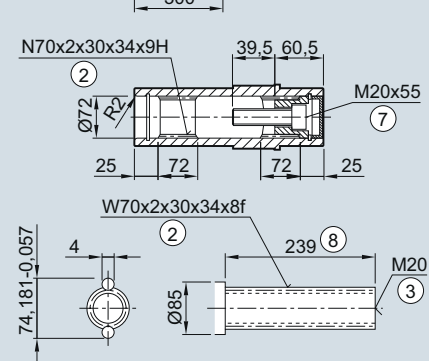
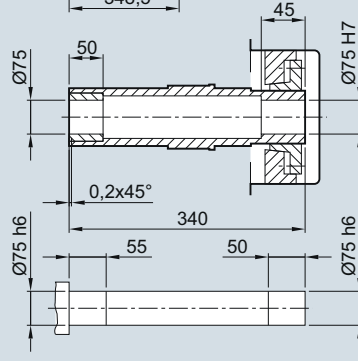
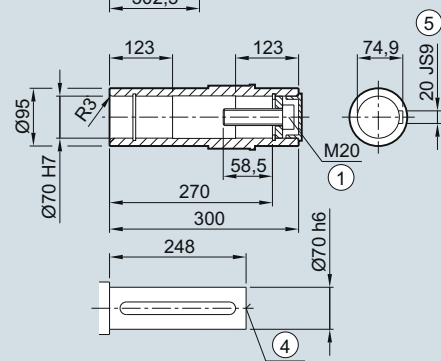
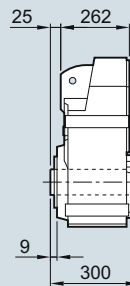

Adapter	a5	b5	c5	f5	e5	s5	z12	d5/D	E	F	GA	k
706	126.0	110	12	4.5	130	M8	15.0	24	50	8	27.0	404.0
708	155.0	130	15	4.5	165	M10	23.5	32	58	10	35.0	439.5
710	192.5	180	18	5.0	215	M12	33.0	38	80	10	41.0	506.5

- ① ISO 4014 ② DIN 5480 ③ DIN 332-D ④ DIN 332 ⑤ Feather key/keyway DIN 6885
- ⑥ ISO 4762 ⑦ Without locating shoulder +1 mm ⑧ For pin holes, see 4/131 ⑨ Use bores only for foot-mounted design

FD.F./FZ.F.129 gearbox in a flange-mounted design

FF030KQ, FAF030KQ, FAFS030KQ, FAFT030KQ

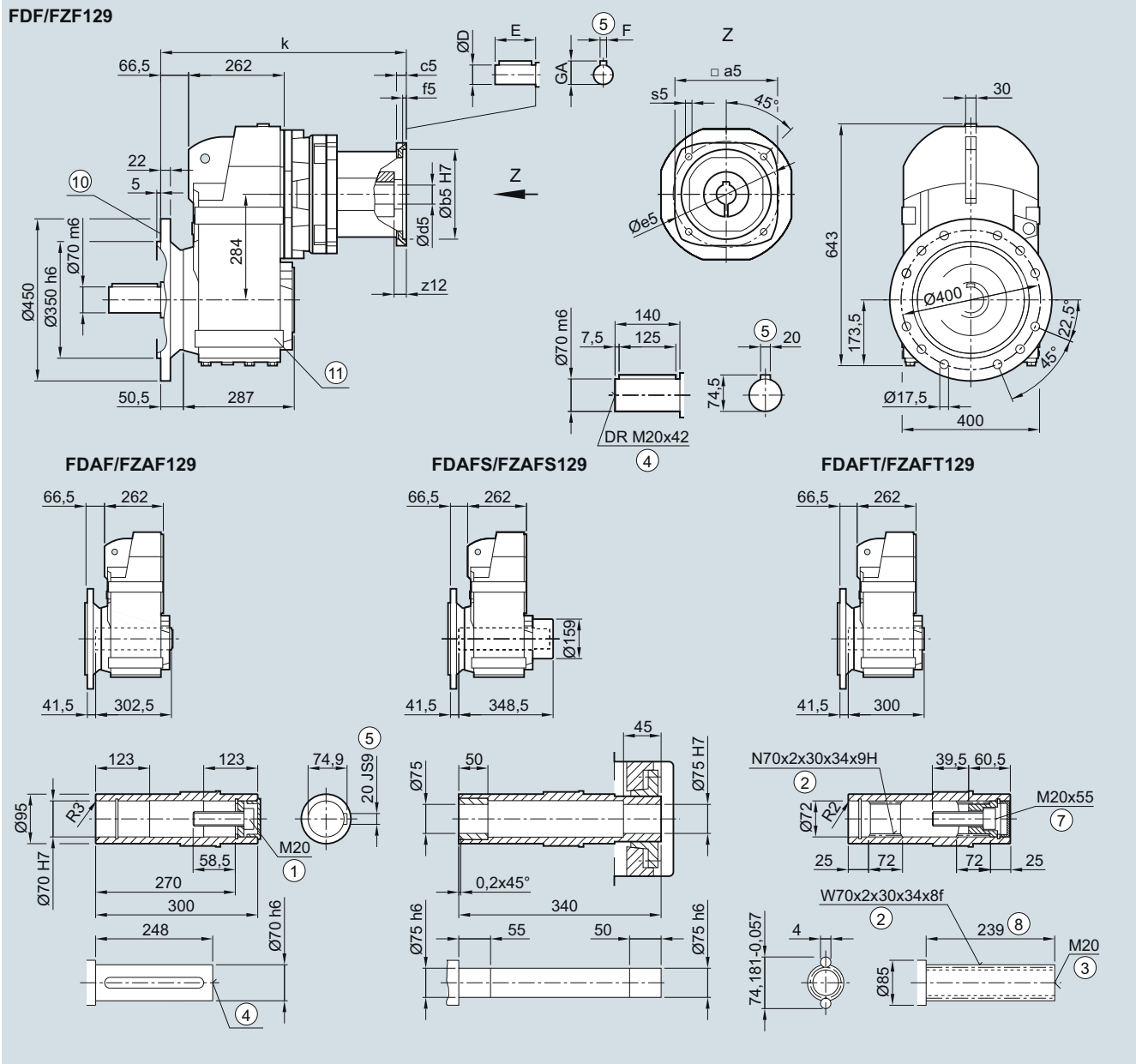

4

Adapter	a5	b5	c5	f5	e5	s5	z12	d5/D	E	F	GA	k
706	126.0	110	12	4.5	130	M8	15.0	24	50	8	27.0	445.5
708	155.0	130	15	4.5	165	M10	23.5	32	58	10	35.0	481.0
710	192.5	180	18	5.0	215	M12	33.0	38	80	10	41.0	548.0

- ① ISO 4014 ② DIN 5480 ③ DIN 332-D ④ DIN 332 ⑤ Feather key/keyway DIN 6885
- ⑦ ISO 4762 ⑥ Without locating shoulder +1 mm ⑩ For inner contour, see page 4/129 ⑪ Use bores only for foot-mounted design

SIMOGEAR Gearboxes

Parallel shaft gearbox with adapter KQ

Dimensions

FD../FZ..129 gearbox in a foot-mounted design

F030KQ, FA030KQ, FAS030KQ, FAT030KQ

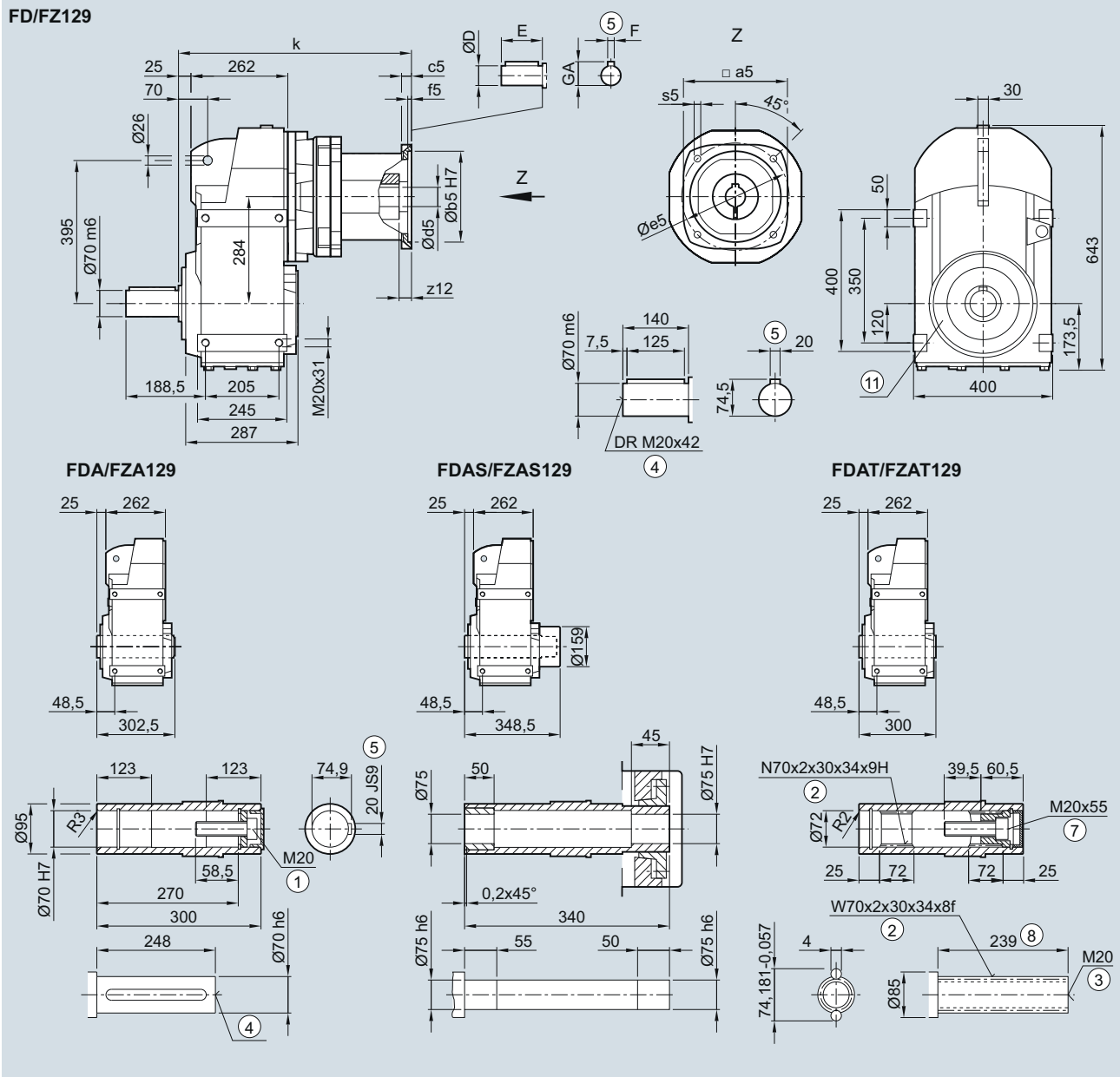

Adapter	a5	b5	c5	f5	e5	s5	z12	d5/D	E	F	GA	k
706	126.0	110	12	4.5	130	M8	15.0	24	50	8	27.0	404.0
708	155.0	130	15	4.5	165	M10	23.5	32	58	10	35.0	439.5
710	192.5	180	18	5.0	215	M12	33.0	38	80	10	41.0	506.5

① ISO 4014

② DIN 5480

③ DIN 332-D

④ DIN 332

⑤ Feather key/keyway DIN 6885

⑦ ISO 4762

⑧ Without locating shoulder +1 mm

⑩ Use bores only for housing flange design

FDAD./FZAD.149 gearbox in a shaft-mounted design

FAD030KQ, FADS030KQ, FADT030KQ

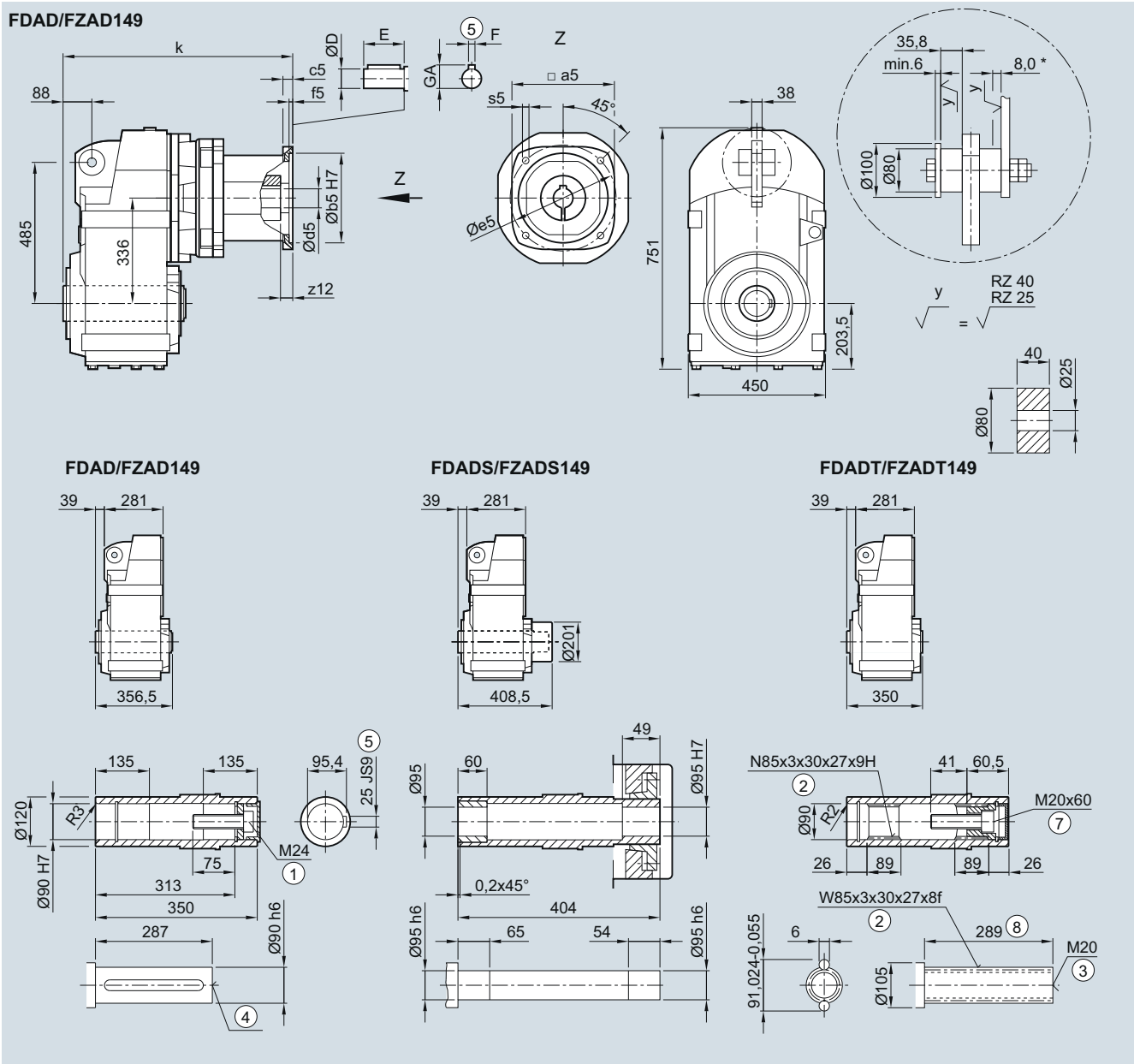

4

Adapter	a5	b5	c5	f5	e5	s5	z12	d5/D	E	F	GA	k
708	155.0	130	15	4.5	165	M10	23.5	32	58	10	35.0	471.5
710	192.5	180	18	5.0	215	M12	33.0	38	80	10	41.0	533.5

① ISO 4014 ② DIN 5480 ③ DIN 332-D ④ DIN 332 ⑤ Feather key/keyway DIN 6885 ⑦ ISO 4762 ⑥ Without locating shoulder +1 mm

SIMOGEAR Gearboxes

Parallel shaft gearbox in a housing flange design

Dimensions

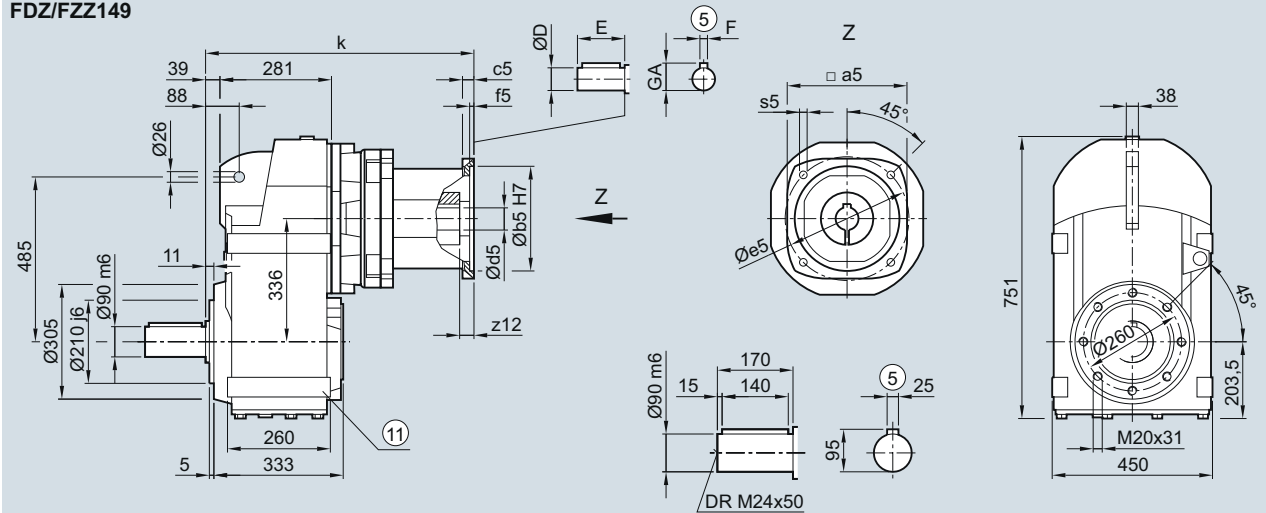
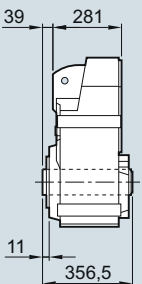
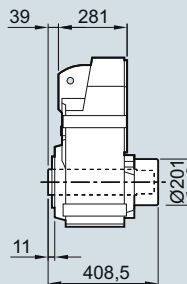
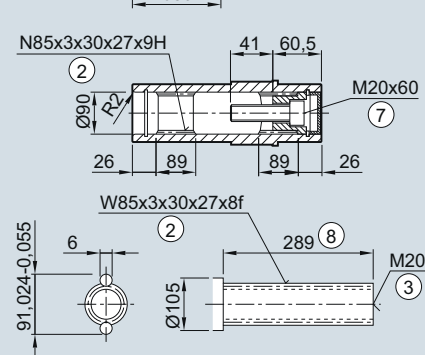
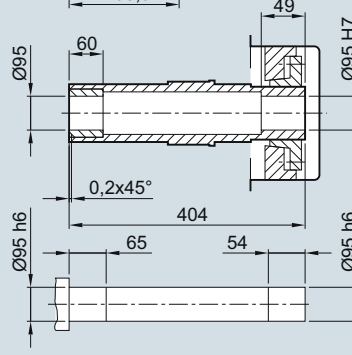
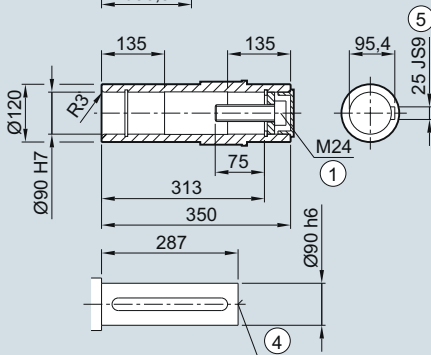
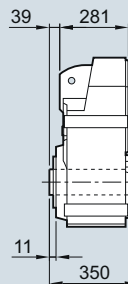
FD.Z./FZ.Z.149 gearbox in a housing flange design**FZ030KQ, FAZ030KQ, FAZS030KQ, FAZT030KQ****FDZ/FZZ149****FDAZ/FZAZ149****FDAZS/FZAZS149****FDAZT/FZAZT149**

Adapter	a5	b5	c5	f5	e5	s5	z12	d5/D	E	F	GA	k
708	155.0	130	15	4.5	165	M10	23.5	32	58	10	35.0	471.5
710	192.5	180	18	5.0	215	M12	33.0	38	80	10	41.0	533.5

① ISO 4014

② DIN 5480

③ DIN 332-D

④ DIN 332

⑤ Feather key/keyway DIN 6885

⑦ ISO 4762

⑧ Without locating shoulder +1 mm

⑩ Use bores only for foot-mounted design

FD.F./FZ.F.149 gearbox in a flange-mounted design

FF030KQ, FAF030KQ, FAFS030KQ, FAFT030KQ

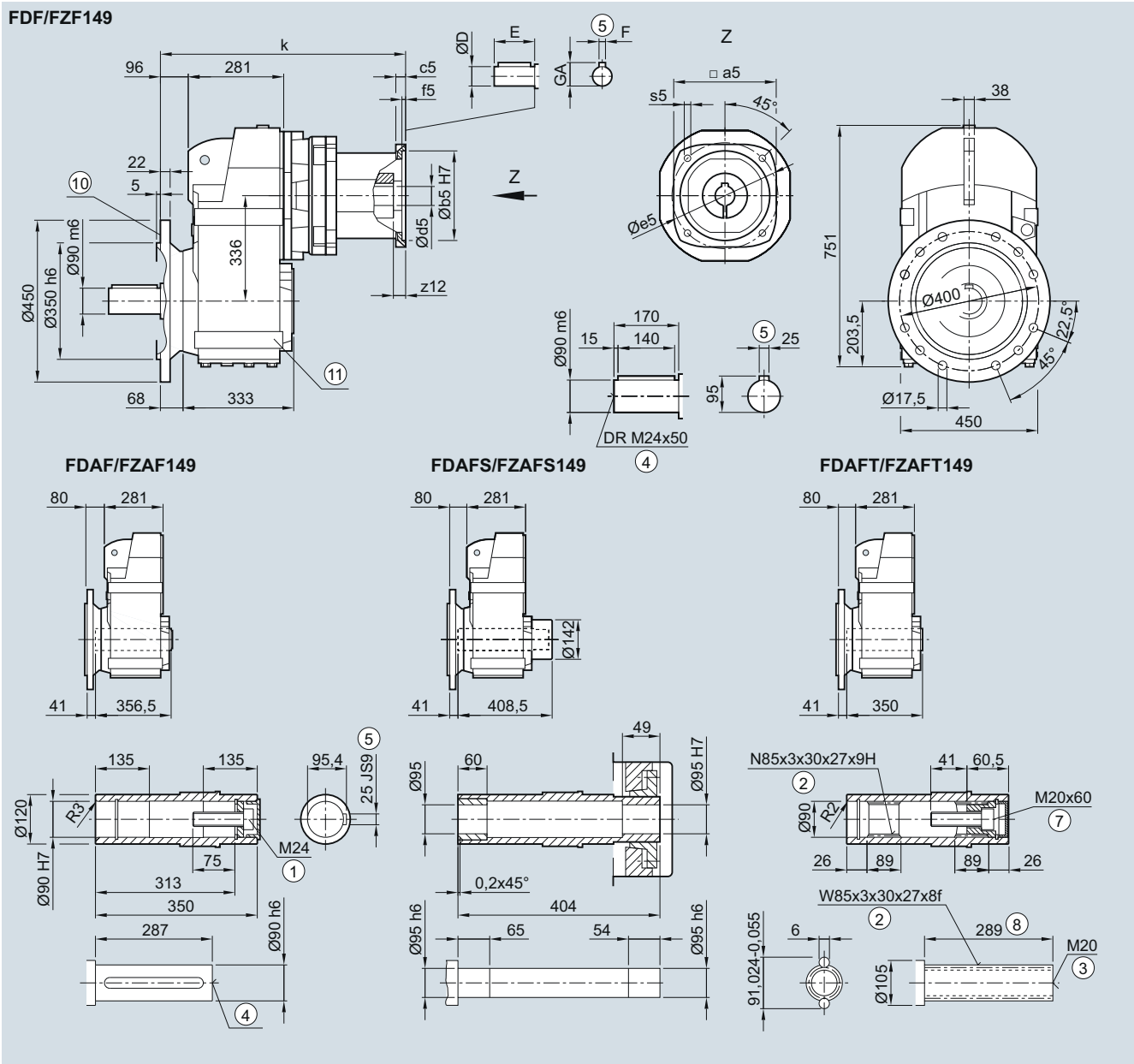

4

Adapter	a5	b5	c5	f5	e5	s5	z12	d5/D	E	F	GA	k
708	155.0	130	15	4.5	165	M10	23.5	32	58	10	35.0	528.5
710	192.5	180	18	5.0	215	M12	33.0	38	80	10	41.0	590.5

- ① ISO 4014 ② DIN 5480 ③ DIN 332-D ④ DIN 332 ⑤ Feather key/keyway DIN 6885
- ⑦ ISO 4762 ⑥ Without locating shoulder +1 mm ⑩ For inner contour, see page 4/129 ⑧ Use bores only for foot-mounted design

SIMOGEAR Gearboxes

Parallel shaft gearbox with adapter KQ

Dimensions

FD../FZ..149 gearbox in a foot-mounted design

F030KQ, FA030KQ, FAS030KQ, FAT030KQ

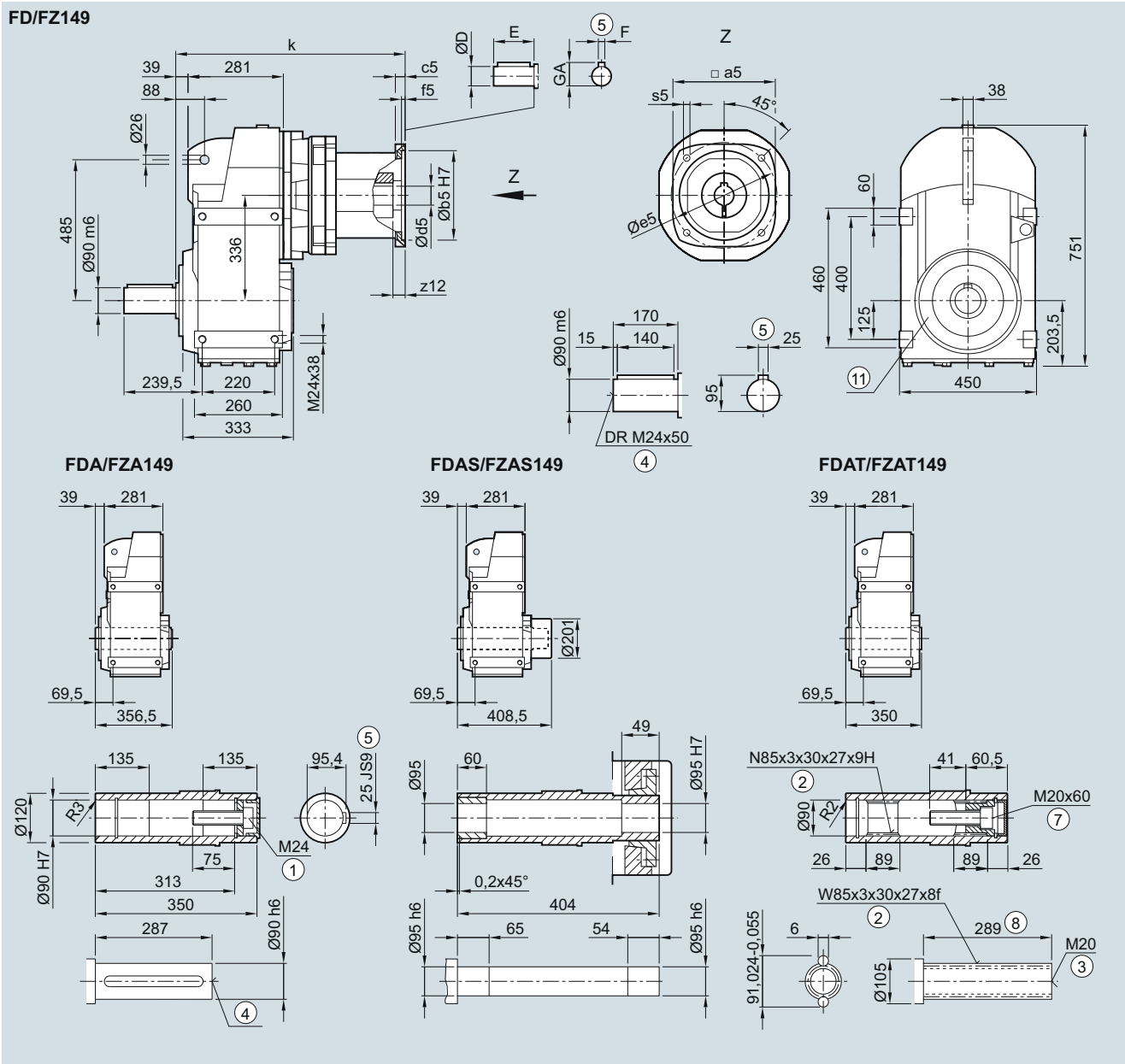

Adapter	a5	b5	c5	f5	e5	s5	z12	d5/D	E	F	GA	k
708	155.0	130	15	4.5	165	M10	23.5	32	58	10	35.0	471.5
710	192.5	180	18	5.0	215	M12	33.0	38	80	10	41.0	533.5

① ISO 4014

② DIN 5480

③ DIN 332-D

④ DIN 332

⑤ Feather key/keyway DIN 6885

⑦ ISO 4762

⑧ Without locating shoulder +1 mm

⑩ Use bores only for foot-mounted design

FDAD./FZAD.169 gearbox in a shaft-mounted design

FAD030KQ, FADS030KQ, FADT030KQ

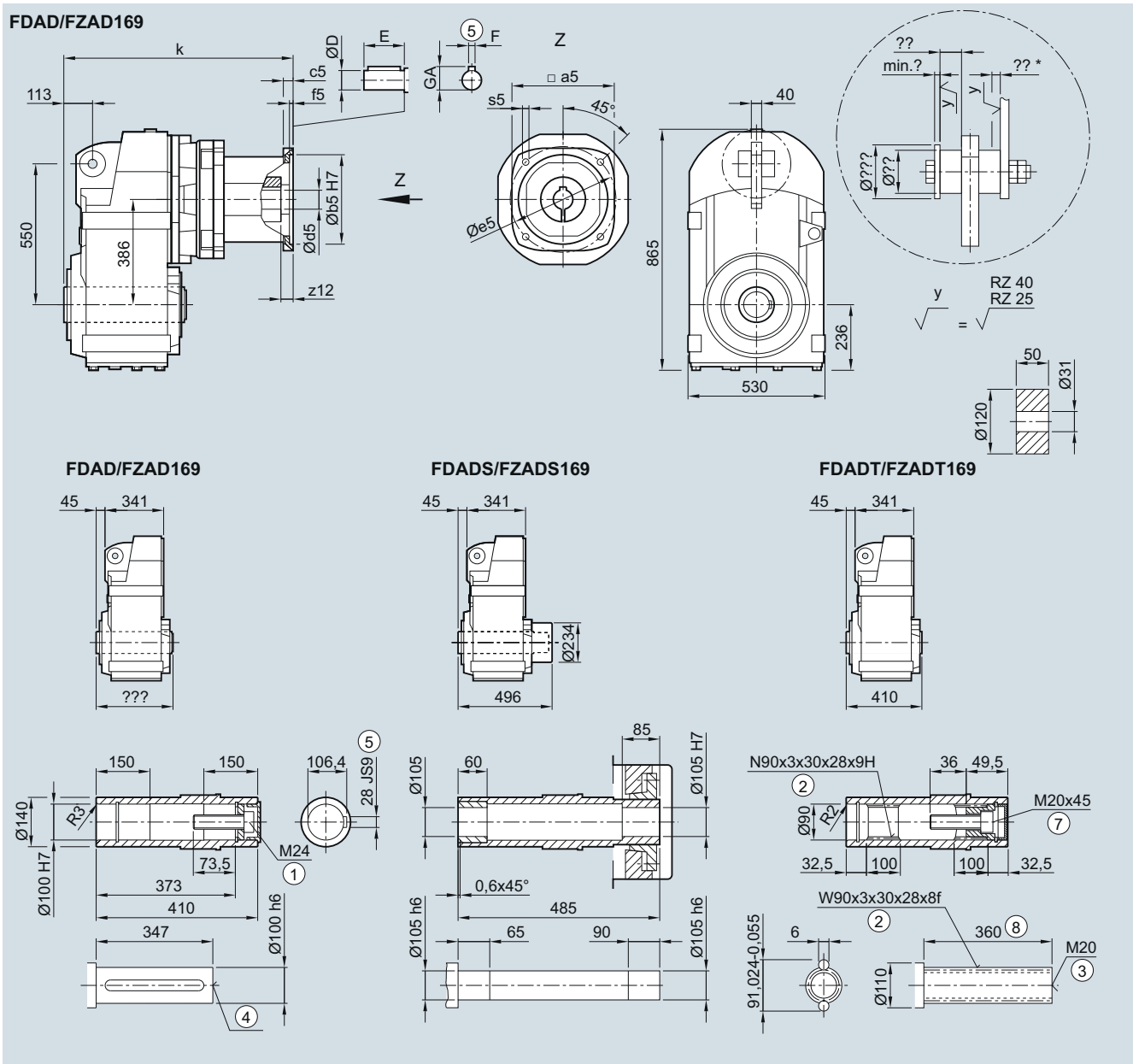

Adapter	a5	b5	c5	f5	e5	s5	z12	d5/D	E	F	GA	k
708	155.0	130	15	4.5	165	M10	23.5	32	58	10	35.0	524.5
710	192.5	180	18	5.0	215	M12	33.0	38	80	10	41.0	586.0

① ISO 4014 ② DIN 5480 ③ DIN 332-D ④ DIN 332 ⑤ Feather key/keyway DIN 6885 ⑦ ISO 4762 ⑥ Without locating shoulder +1 mm

SIMOGEAR Gearboxes

Parallel shaft gearbox with adapter KQ

Dimensions

FD.Z./FZ.Z.169 gearbox in a housing flange design

FZ030KQ, FAZ030KQ, FAZS030KQ, FAZT030KQ

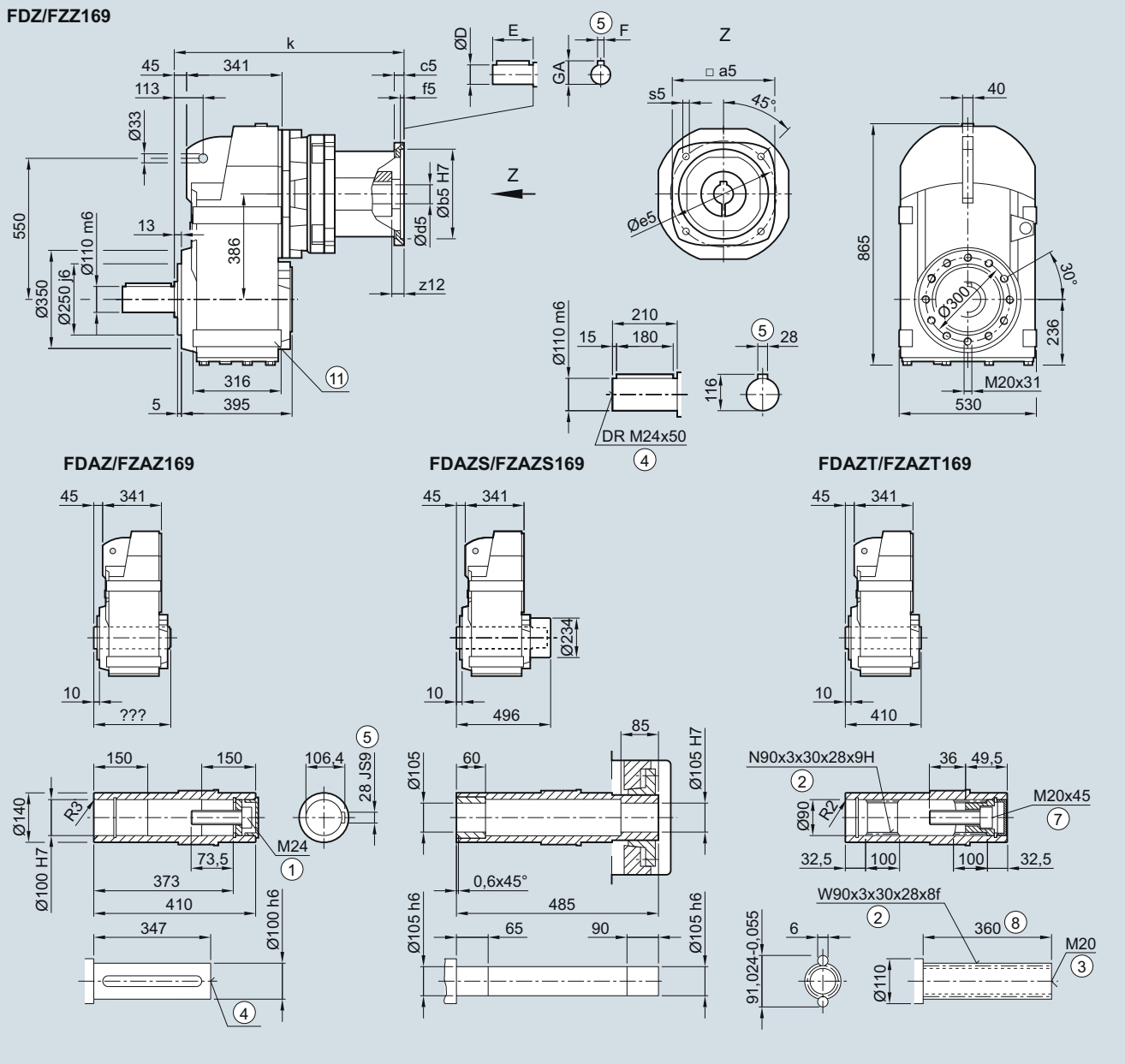

Adapter	a5	b5	c5	f5	e5	s5	z12	d5/D	E	F	GA	k
708	155.0	130	15	4.5	165	M10	23.5	32	58	10	35.0	524.5
710	192.5	180	18	5.0	215	M12	33.0	38	80	10	41.0	586.0

① ISO 4014

② DIN 5480

③ DIN 332-D

④ DIN 332

⑤ Feather key/keyway DIN 6885

⑦ ISO 4762

⑧ Without locating shoulder +1 mm

⑩ Use bores only for foot-mounted design

FD.F./FZ.F.169 gearbox in a flange-mounted design

FF030KQ, FAF030KQ, FAFS030KQ, FAFT030KQ

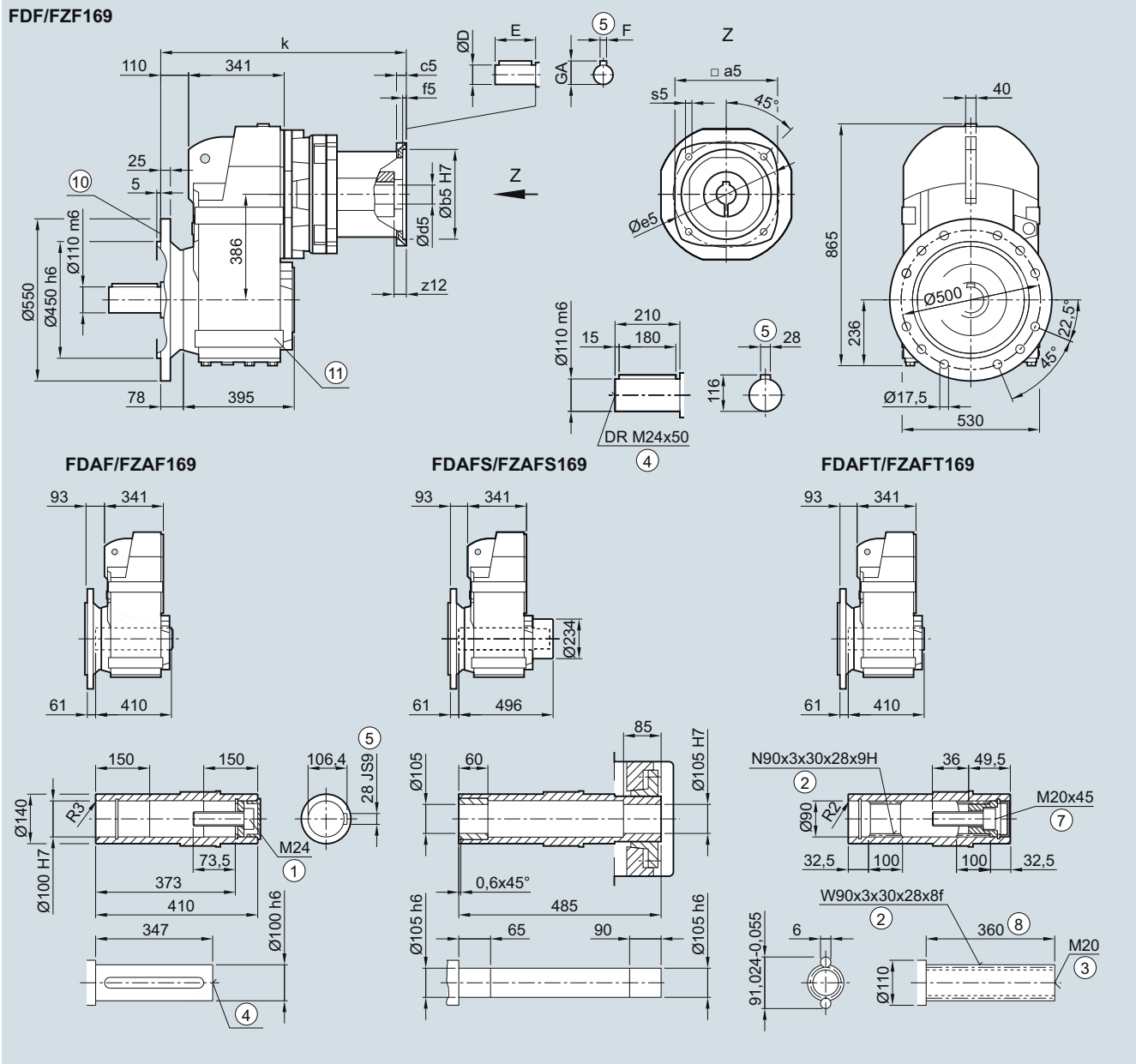

4

Adapter	a5	b5	c5	f5	e5	s5	z12	d5/D	E	F	GA	k
708	155.0	130	15	4.5	165	M10	23.5	32	58	10	35.0	589.5
710	192.5	180	18	5.0	215	M12	33.0	38	80	10	41.0	651.0

- ① ISO 4014 ② DIN 5480 ③ DIN 332-D ④ DIN 332 ⑤ Feather key/keyway DIN 6885
- ⑦ ISO 4762 ⑥ Without locating shoulder +1 mm ⑩ For inner contour, see page 4/129 ⑪ Use bores only for foot-mounted design

SIMOGEAR Gearboxes

Parallel shaft gearbox with adapter KQ

Dimensions

FD../FZ..169 gearbox in a foot-mounted design

F030KQ, FA030KQ, FAS030KQ, FAT030KQ

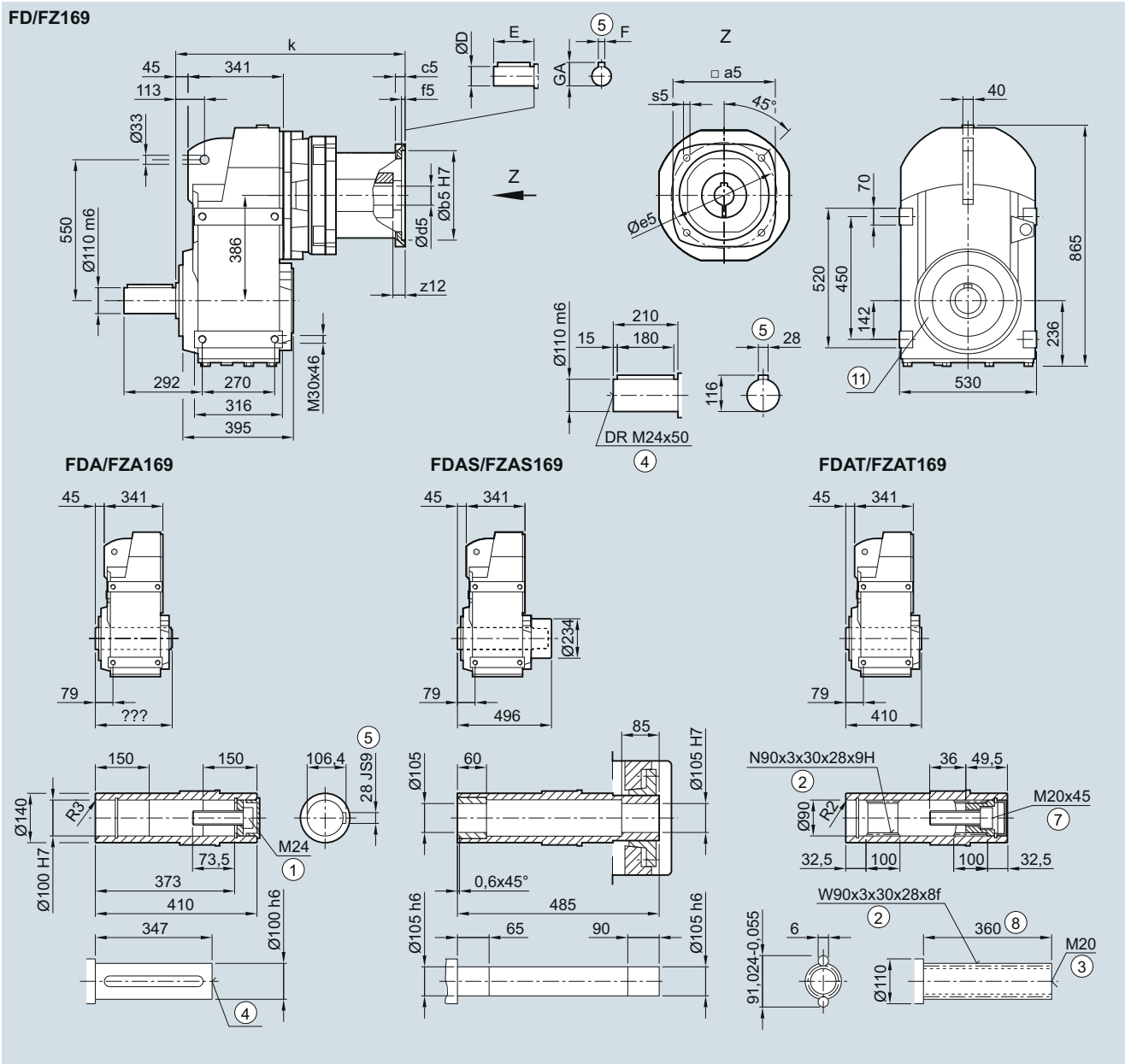

Adapter	a5	b5	c5	f5	e5	s5	z12	d5/D	E	F	GA	k
708	155.0	130	15	4.5	165	M10	23.5	32	58	10	35.0	524.5
710	192.5	180	18	5.0	215	M12	33.0	38	80	10	41.0	586.0

- ① ISO 4014 ② DIN 5480 ③ DIN 332-D ④ DIN 332
- ⑤ Feather key/keyway DIN 6885 ⑦ ISO 4762 ⑧ Without locating shoulder +1 mm ⑩ Use bores only for housing flange design

FDAD./FZAD.189 gearbox in a shaft-mounted design

FAD030KQ, FADS030KQ, FADT030KQ

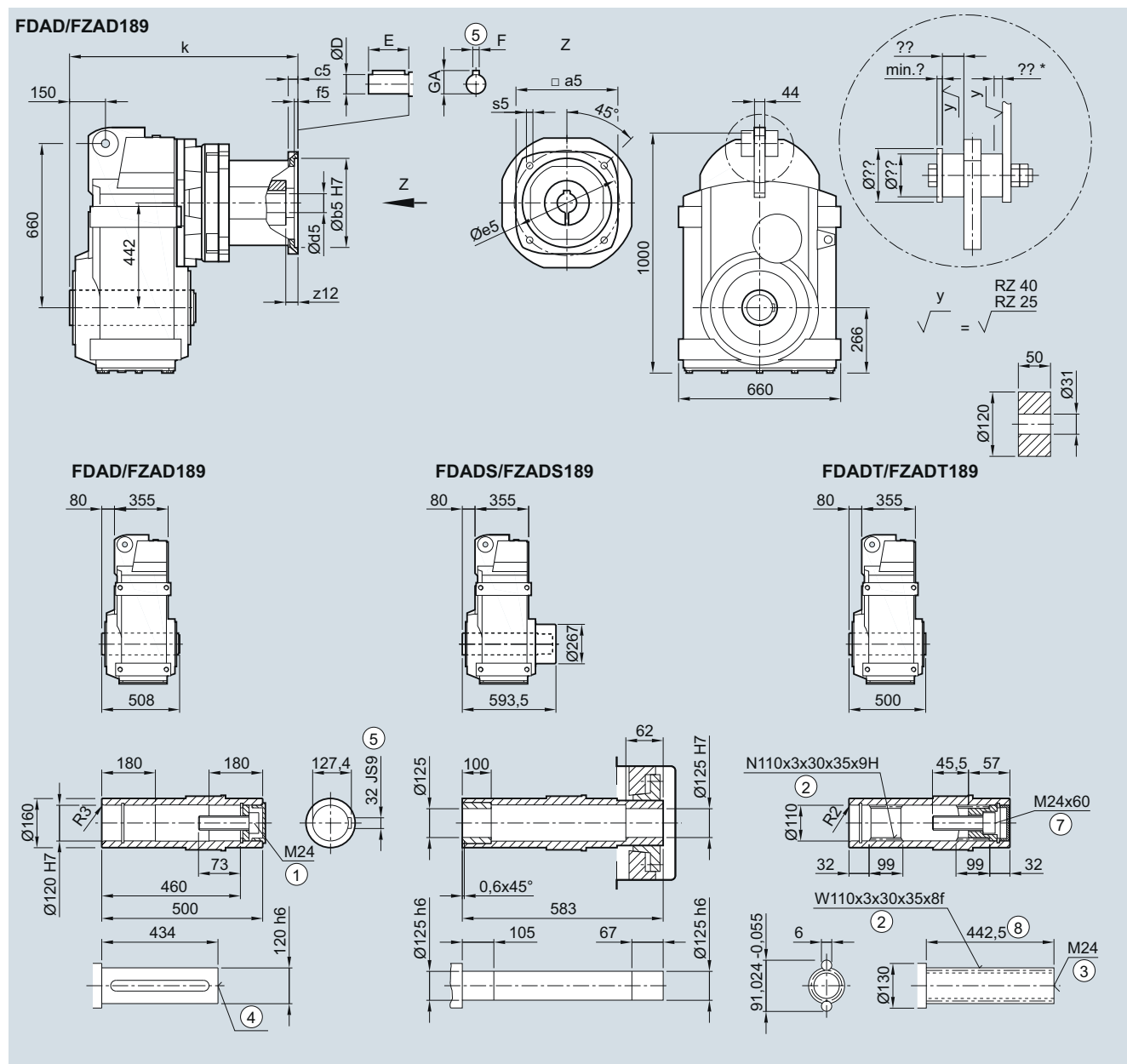

Adapter	a5	b5	c5	f5	e5	s5	z12	d5/D	E	F	GA	k
708	155.0	130	15	4.5	165	M10	23.5	32	58	10	35.0	573.5
710	192.5	180	18	5.0	215	M12	33.0	38	80	10	41.0	635.0

① ISO 4014 ② DIN 5480 ③ DIN 332-2 ④ DIN 332 ⑤ Feather key/keyway DIN 6885 ⑦ ISO 4762 ⑧ Without locating shoulder +1 mm

SIMOGEAR Gearboxes

Parallel shaft gearbox in a housing flange design

Dimensions

FD.Z./FZ.Z.189 gearbox in a housing flange design

FZ030KQ, FAZ030KQ, FAZS030KQ, FAZT030KQ

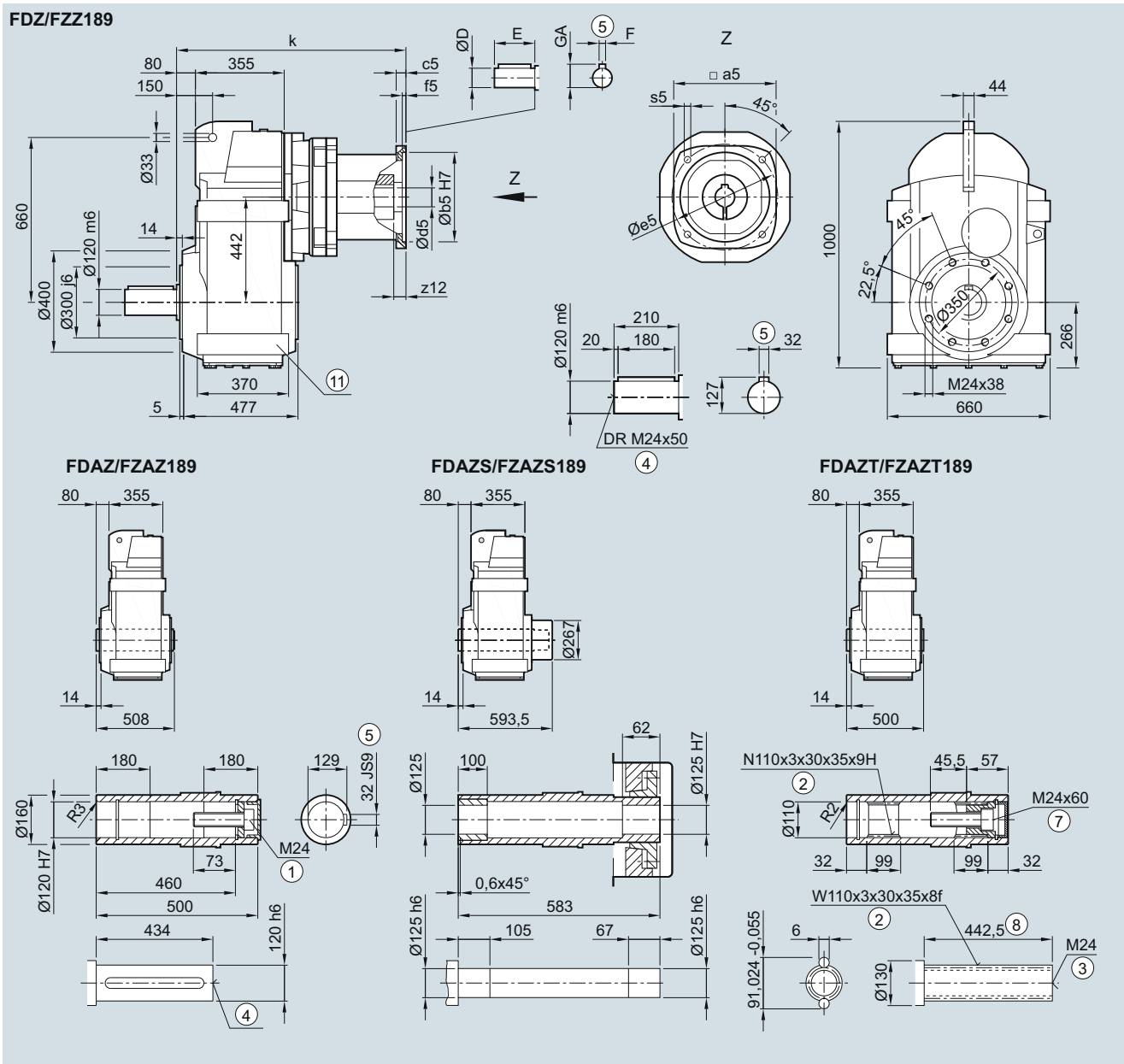

Adapter	a5	b5	c5	f5	e5	s5	z12	d5/D	E	F	GA	k
708	155.0	130	15	4.5	165	M10	23.5	32	58	10	35.0	573.5
710	192.5	180	18	5.0	215	M12	33.0	38	80	10	41.0	635.0

① ISO 4014

② DIN 5480

③ DIN 332-D

④ DIN 332

⑤ Feather key/keyway DIN 6885

⑦ ISO 4762

⑧ Without locating shoulder +1 mm

⑩ Use bores only for foot-mounted design

FD.F./FZ.F.189 gearbox in a flange-mounted design

FF030KQ, FAF030KQ, FAFS030KQ, FAFT030KQ

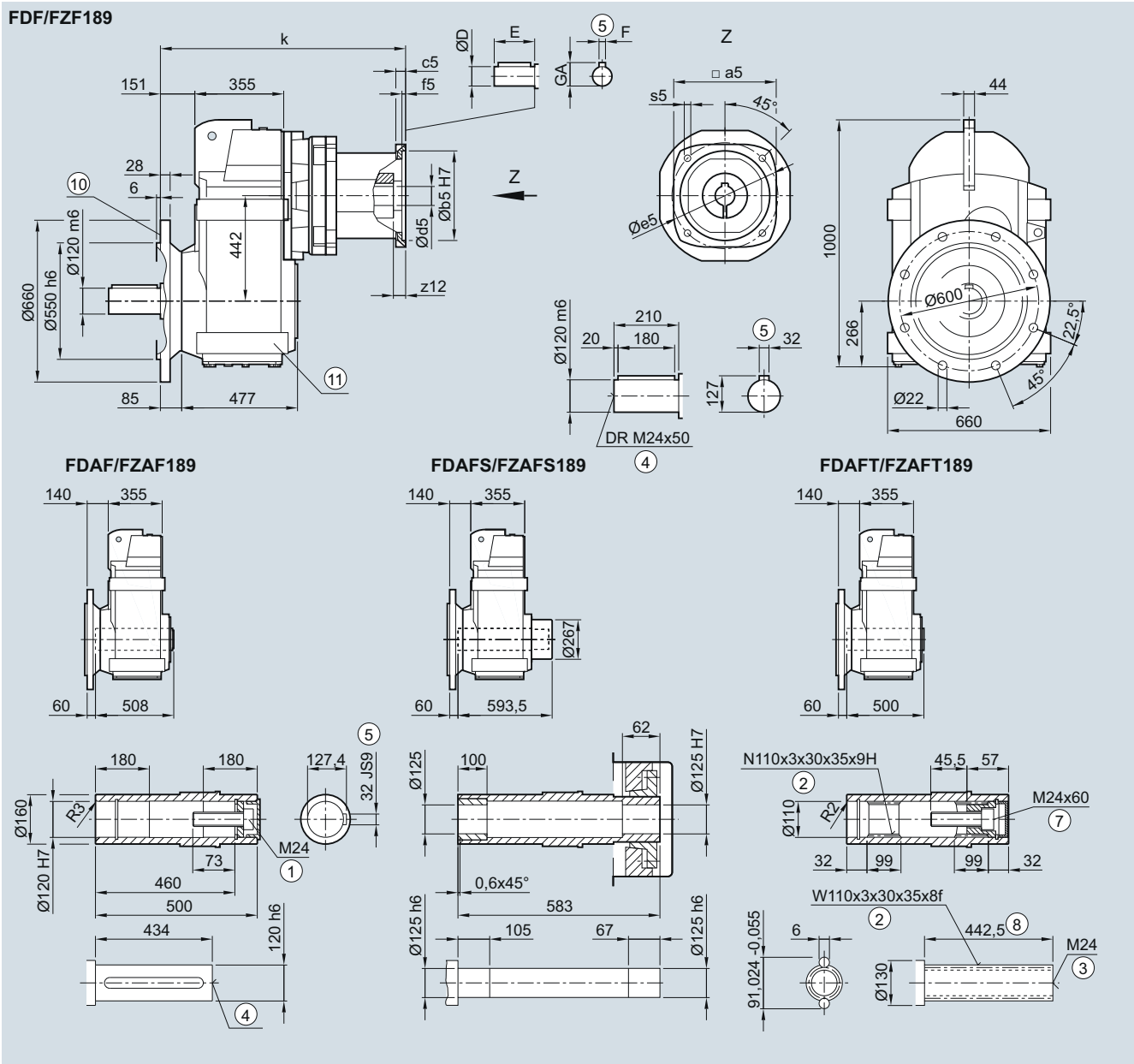

4

Adapter	a5	b5	c5	f5	e5	s5	z12	d5/D	E	F	GA	k
708	155.0	130	15	4.5	165	M10	23.5	32	58	10	35.0	644.5
710	192.5	180	18	5.0	215	M12	33.0	38	80	10	41.0	706.0

- ① ISO 4014 ② DIN 5480 ③ DIN 332-D ④ DIN 332 ⑤ Feather key/keyway DIN 6885
- ⑦ ISO 4762 ⑥ Without locating shoulder +1 mm ⑩ For inner contour, see page 4/129 ⑪ Use bores only for foot-mounted design

SIMOGEAR Gearboxes

Parallel shaft gearbox with adapter KQ

Dimensions

FD../FZ..189 gearbox in a foot-mounted design

F030KQ, FA030KQ, FAS030KQ, FAT030KQ

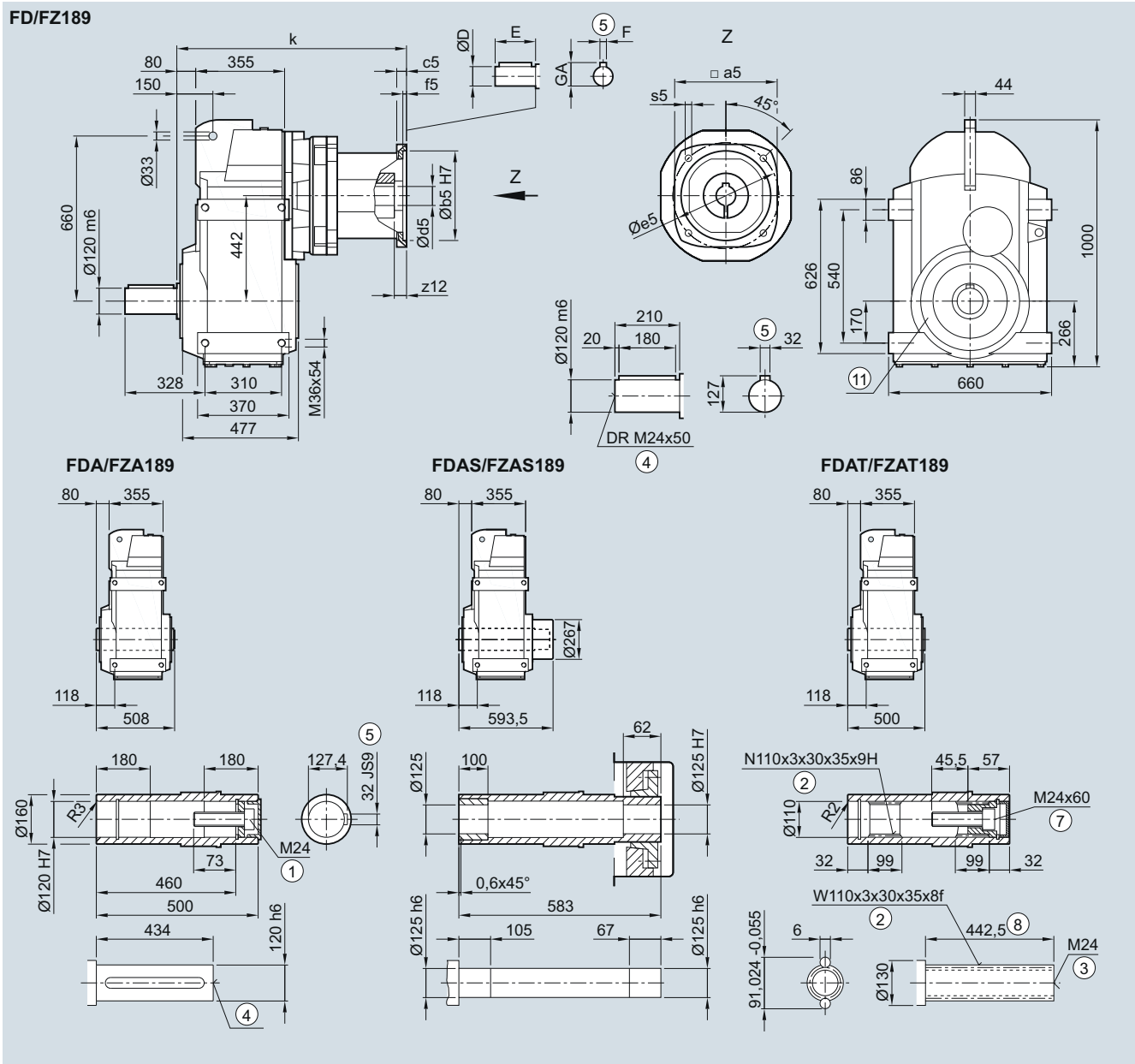

Adapter	a5	b5	c5	f5	e5	s5	z12	d5/D	E	F	GA	k
708	155.0	130	15	4.5	165	M10	23.5	32	58	10	35.0	573.5
710	192.5	180	18	5.0	215	M12	33.0	38	80	10	41.0	635.0

① ISO 4014

② DIN 5480

③ DIN 332-D

④ DIN 332

⑤ Feather key/keyway DIN 6885

⑦ ISO 4762

⑧ Without locating shoulder +1 mm

⑩ Use bores only for housing flange design

FD.../FZ...29 to FD.../FZ...79 gearboxes

F.AD.030KQS, F.Z.030KQS, F.F.030KQS, F..030KQS

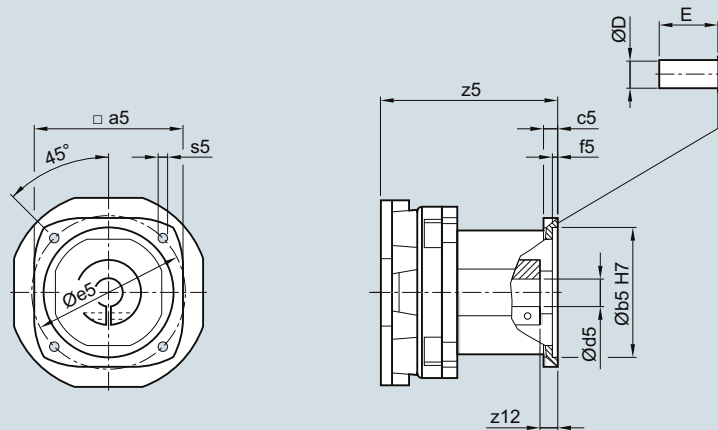

Adapter	a5	b5	c5	f5	e5	s5	z12	d5/D	E	z5
FD.../FZ...29										
703	71.6	60	9	4.0	75	M5	18.0	14	30	99.5
704	96.5	80	10	4.0	100	M6	14.0	19	40	146.5
706	126.0	110	12	4.5	130	M8	15.0	24	50	159.5
FD.../FZ...39										
703	71.6	60	9	4.0	75	M5	18.0	14	30	99.5
704	96.5	80	10	4.0	100	M6	14.0	19	40	146.5
706	126.0	110	12	4.5	130	M8	15.0	24	50	159.5
708	155.0	130	15	4.5	165	M10	23.5	32	58	203.0
35										
316	71.6	60	9	4.0	75	M5	18.0	14	30	90.0
704	96.5	80	10	4.0	100	M6	14.0	19	40	137.0
706	126.0	110	12	4.5	130	M8	15.0	24	50	150.0
708	155.0	130	15	4.5	165	M10	23.5	32	58	193.5
710	192.5	180	15	5.0	215	M12	33.0	38	80	262.5
FD.../FZ...69										
703	71.6	60	9	4.0	75	M5	18.0	14	30	90.0
704	96.5	80	10	4.0	100	M6	14.0	19	40	137.0
706	126.0	110	12	4.5	130	M8	15.0	24	50	150.0
708	155.0	130	15	4.5	165	M10	23.5	32	58	193.5
710	192.5	180	15	5.0	215	M12	33.0	38	80	262.5
FD.../FZ...79										
703	71.6	60	9	4.0	75	M5	18.0	14	30	88.0
704	96.5	80	10	4.0	100	M6	14.0	19	40	131.0
706	126.0	110	12	4.5	130	M8	15.0	24	50	144.0
708	155.0	130	15	4.5	165	M10	23.5	32	58	187.5
710	192.5	180	15	5.0	215	M12	33.0	38	80	256.5

SIMOGEAR Gearboxes

Parallel shaft gearbox with adapter KQS

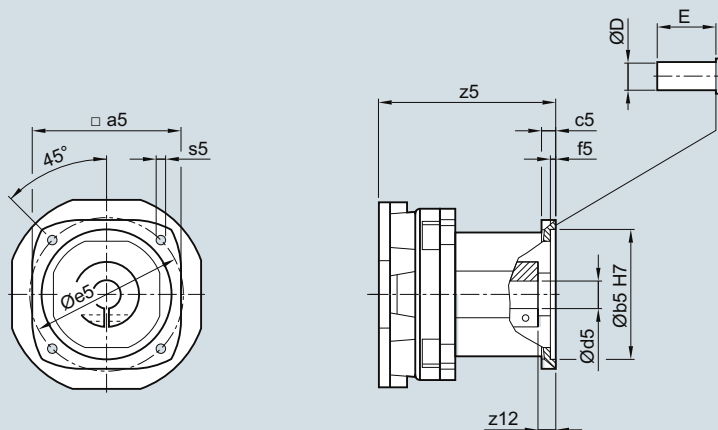
Dimensions**FD.../FZ...89 to FD.../FZ...189 gearboxes****F.AD.030KQS, F.Z.030KQS, F.F.030KQS, F..030KQS**

Adapter	a5	b5	c5	f5	e5	s5	z12	d5/D	E	z5
FD.../FZ...89										
704	96.5	80	10	4.0	100	M6	14.0	19	40	118.0
706	126.0	110	12	4.5	130	M8	15.0	24	50	131.0
708	155.0	130	15	4.5	165	M10	23.5	32	58	170.5
710	192.5	180	15	5.0	215	M12	33.0	38	80	239.5
FD.../FZ...109										
706	126.0	110	12	4.5	130	M8	15.0	24	50	124.0
708	155.0	130	15	4.5	165	M10	23.5	32	58	161.5
710	192.5	180	15	5.0	215	M12	33.0	38	80	230.5
FD.../FZ...129										
706	126.0	110	12	4.5	130	M8	15.0	24	50	117.0
708	155.0	130	15	4.5	165	M10	23.5	32	58	152.5
710	192.5	180	15	5.0	215	M12	33.0	38	80	219.5
FD.../FZ...149										
708	155.0	130	15	4.5	165	M10	23.5	32	58	151.0
710	192.5	180	15	5.0	215	M12	33.0	38	80	213.0
FD.../FZ...169										
708	155.0	130	15	4.5	165	M10	23.5	32	58	138.5
710	192.5	180	15	5.0	215	M12	33.0	38	80	200.0
FD.../FZ...189										
708	155.0	130	15	4.5	165	M10	23.5	32	58	138.5
710	192.5	180	15	5.0	215	M12	33.0	38	80	200.0

FD.../FZ...39 to FD.../FZ...189 gearboxes

F.AD.030K8 F.Z.030K8, F.F.030K8, F..030K8

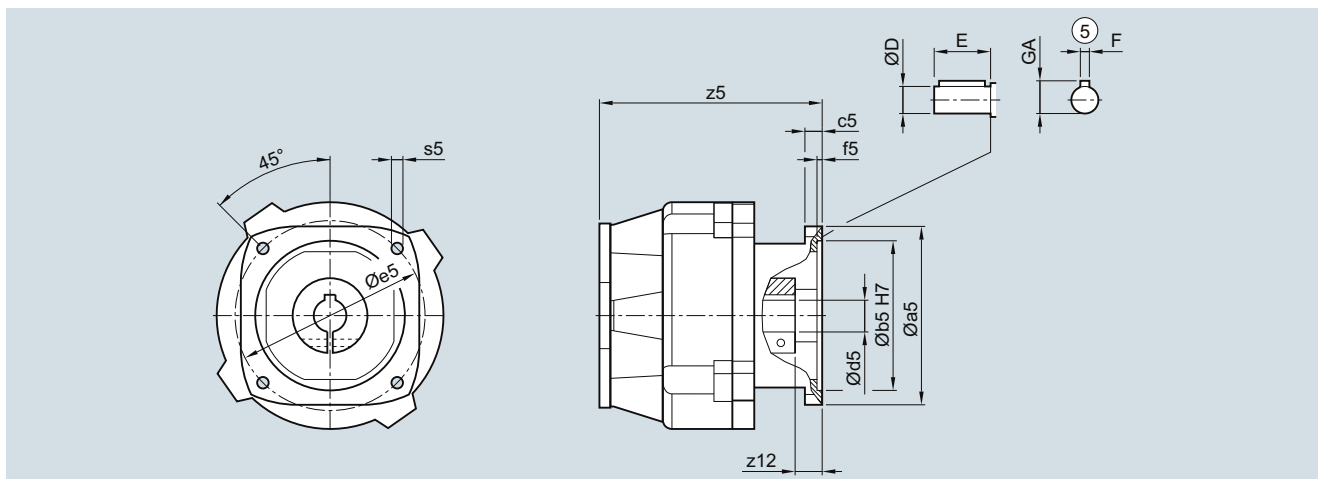

Adapter	a5	b5	c5	f5	e5	s5	z12	d5/D	E	F	GA	z5
FD.../FZ...39												
808	155.0	130	35	4.5	165	M10	43.5	32	80	10	35.0	223.0
FD.../FZ...49												
808	155.0	130	35	4.5	165	M10	43.5	32	80	10	35.0	213.5
810	192.5	180	15	5.0	215	M12	33.0	38	80	10	41.0	262.5
FD.../FZ...69												
808	155.0	130	35	4.5	165	M10	43.5	32	80	10	35.0	213.5
810	192.5	180	15	5.0	215	M12	33.0	38	80	10	41.0	262.5
FD.../FZ...79												
808	155.0	130	35	4.5	165	M10	43.5	32	80	10	35.0	207.5
810	192.5	180	15	5.0	215	M12	33.0	38	80	10	41.0	256.5
FD.../FZ...89												
808	155.0	130	35	4.5	165	M10	43.5	32	80	10	35.0	190.5
810	192.5	180	15	5.0	215	M12	33.0	38	80	10	41.0	239.5
813	260	250	25	6.0	300	M16	60.0	48	110	14	51.5	317.5
FD.../FZ...109												
808	155.0	130	35	4.5	165	M10	43.5	32	80	10	35.0	181.5
810	192.5	180	15	5.0	215	M12	33.0	38	80	10	41.0	230.5
813	260.0	250	25	6.0	300	M16	60.0	48	110	14	51.5	308.5
816	314.0	300	-	6.0	350	M16x29	60.0	55	110	16	59.0	365.0
FD.../FZ...129												
808	155.0	130	35	4.5	165	M10	43.5	32	80	10	35.0	172.5
810	192.5	180	15	5.0	215	M12	33.0	38	80	10	41.0	219.5
813	260.0	250	25	6.0	300	M16	60.0	48	110	14	51.5	297.5
816	314.0	300	-	6.0	350	M16x29	60.0	55	110	16	59.0	360.0
FD.../FZ...149												
808	155.0	130	35	4.5	165	M10	43.5	32	80	10	35.0	171.0
810	192.5	180	15	5.0	215	M12	33.0	38	80	10	41.0	213.0
813	260.0	250	25	6.0	300	M16	60.0	48	110	14	51.5	291.0
816	314.0	300	-	6.0	350	M16x29	60.0	55	110	16	59.0	347.5
818	550	350	22.0	12.0	400	M16	73	65	140	18	69	336.5
FD.../FZ...169												
808	155.0	130	35	4.5	165	M10	43.5	32	80	10	35.0	158.5
810	192.5	180	15	5.0	215	M12	33.0	38	80	10	41.0	200.0
813	260.0	250	25	6.0	300	M16	60.0	48	110	14	51.5	278.0
816	314.0	300	-	6.0	350	M16x29	60.0	55	110	16	59.0	333.0
818	550	350	22.0	12.0	400	M16	73	65	140	18	69	319.5
FD.../FZ...189												
808	155.0	130	35	4.5	165	M10	43.5	32	80	10	35.0	158.5
810	192.5	180	15	5.0	215	M12	33.0	38	80	10	41.0	200.0
813	260.0	250	25	6.0	300	M16	60.0	48	110	14	51.5	278.0
816	314.0	300	-	6.0	350	M16x29	60.0	55	110	16	59.0	333.0
818	550	350	22.0	12.0	400	M16	73	65	140	18	69	319.5
822	660	450	58.5	25.0	500	M16	58.5	75	140	20	79.5	346.5

© Feather key/keyway DIN 6885

SIMOGEAR Gearboxes

Parallel shaft gearbox with adapter K5

Dimensions

FD.../FZ...29 to FD.../FZ...89 gearboxes

F.AD.030K5, F.Z.030K5, F.F.030K5, F..030K5

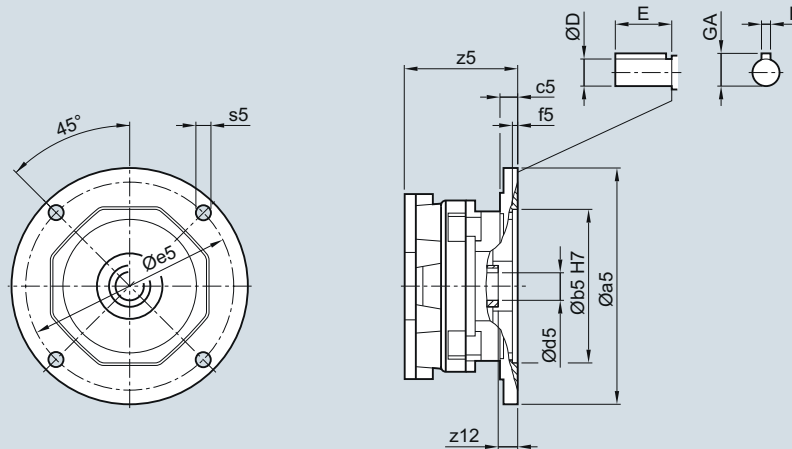

Adapter	a5	b5	c5	f5	e5	s5	z12	d5/D	E	F	GA	z5
FD.../FZ...29												
56	168	114.3	15	5.0	149.2	11.0	16	15.875	47.752	4.763	17.895	118.5
140	168	114.3	15	5.0	149.2	11.0	16	22.225	57.150	4.763	24.346	118.5
180	226	215.9	22	5.5	184.1	13.5	26	28.575	69.850	6.350	31.394	200.5
FD.../FZ...39												
56	168	114.3	15	5.0	149.2	11.0	16	15.875	47.752	4.763	17.895	118.5
140	168	114.3	15	5.0	149.2	11.0	16	22.225	57.150	4.763	24.346	118.5
180	226	215.9	22	5.5	184.1	13.5	26	28.575	69.850	6.350	31.394	200.5
FD.../FZ...49												
56	168	114.3	15	5.0	149.2	11.0	16	15.875	47.752	4.763	17.895	109.0
140	168	114.3	15	5.0	149.2	11.0	16	22.225	57.150	4.763	24.346	109.0
180	226	215.9	22	5.5	184.1	13.5	26	28.575	69.850	6.350	31.394	191.0
210	226	215.9	22	5.5	184.1	13.5	12	34.925	85.850	7.938	38.443	207.0
FD.../FZ...69												
56	168	114.3	15	5.0	149.2	11.0	16	15.875	47.752	4.763	17.895	109.0
140	168	114.3	15	5.0	149.2	11.0	16	22.225	57.150	4.763	24.346	109.0
180	226	215.9	22	5.5	184.1	13.5	26	28.575	69.850	6.350	31.394	191.0
210	226	215.9	22	5.5	184.1	13.5	12	34.925	85.850	7.938	38.443	207.0
FD.../FZ...79												
56	168	114.3	15	5.0	149.2	11.0	16	15.875	47.752	4.763	17.895	103.0
140	168	114.3	15	5.0	149.2	11.0	16	22.225	57.150	4.763	24.346	103.0
180	226	215.9	22	5.5	184.1	13.5	26	28.575	69.850	6.350	31.394	185.0
210	226	215.9	22	5.5	184.1	13.5	12	34.925	85.850	7.938	38.443	201.0
250	226	215.9	22	5.5	184.1	13.5	12	41.275	101.600	9.525	45.491	201.0
FD.../FZ...89												
140	168	114.3	15	5.0	149.2	11.0	16	22.225	57.150	4.763	24.346	90.0
180	226	215.9	22	5.5	184.1	13.5	26	28.575	69.850	6.350	31.394	168.0
210	226	215.9	22	5.5	184.1	13.5	12	34.925	85.850	7.938	38.443	184.0
250	226	215.9	22	5.5	184.1	13.5	12	41.275	101.600	9.525	45.491	184.0

FD.../FZ...109 to FD.../FZ...189 gearboxes

F.AD.030K5, F.Z.030K5, F.F.030K5, F..030K5

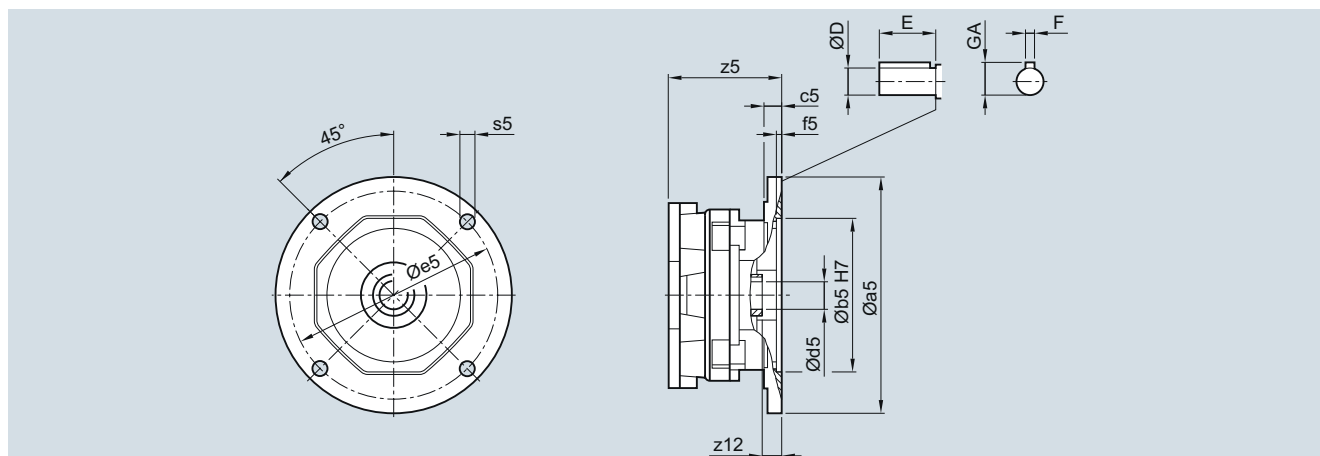

Adapter	a5	b5	c5	f5	e5	s5	z12	d5/D	E	F	GA	z5
FD.../FZ...109												
140	168	114.3	15.0	5.0	149.2	11.0	16	22.225	57.150	4.763	24.346	90.0
180	226	215.9	22.0	5.5	184.1	13.5	26	28.575	69.850	6.350	31.394	168.0
210	226	215.9	22.0	5.5	184.1	13.5	12	34.925	85.850	7.938	38.443	184.0
250	226	215.9	22.0	5.5	184.1	13.5	12	41.275	101.600	9.525	45.491	184.0
280	285	266.7	24.5	5.5	228.6	13.5	22.0	47.625	117.602	12.70	53.111	188.0
320	340	317.5	26.5	5.5	279.4	17.0	32.5	53.975	133.350	12.70	59.563	264.5
FD.../FZ...129												
140	168	114.3	15.0	5.0	149.2	11.0	16	22.225	57.150	4.763	24.346	90.0
180	226	215.9	22.0	5.5	184.1	13.5	26	28.575	69.850	6.350	31.394	168.0
210	226	215.9	22.0	5.5	184.1	13.5	12	34.925	85.850	7.938	38.443	184.0
250	226	215.9	22.0	5.5	184.1	13.5	12	41.275	101.600	9.525	45.491	184.0
280	285	266.7	24.5	5.5	228.6	13.5	22.0	47.625	117.602	12.70	53.111	188.0
320	340	317.5	26.5	5.5	279.4	17.0	32.5	53.975	133.350	12.70	59.563	264.5
360	340	317.5	26.5	5.5	279.4	17.0	34.5	60.325	149.352	15.875	67.208	278.0
FD.../FZ...149												
180	226	215.9	22.0	5.5	184.1	13.5	26	28.575	69.850	6.350	31.394	148.5
210	226	215.9	22.0	5.5	184.1	13.5	12	34.925	85.850	7.938	38.443	157.5
250	226	215.9	22.0	5.5	184.1	13.5	12	41.275	101.600	9.525	45.491	157.5
280	285	266.7	24.5	5.5	228.6	13.5	22.0	47.625	117.602	12.70	53.111	170.5
320	340	317.5	26.5	5.5	279.4	17.0	32.5	53.975	133.350	12.70	59.563	247.0
360	340	317.5	26.5	5.5	279.4	17.0	34.5	60.325	149.352	15.875	67.208	271.5
FD.../FZ...169												
210	226	215.9	22.0	5.5	184.1	13.5	12	34.925	85.850	7.938	38.443	144.5
250	226	215.9	22.0	5.5	184.1	13.5	12	41.275	101.600	9.525	45.491	144.5
280	285	266.7	24.5	5.5	228.6	13.5	22.0	47.625	117.602	12.70	53.111	157.5
320	340	317.5	26.5	5.5	279.4	17.0	32.5	53.975	133.350	12.70	59.563	232.0
360	340	317.5	26.5	5.5	279.4	17.0	34.5	60.325	149.352	15.875	67.208	253.0
FD.../FZ...189												
210	226	215.9	22.0	5.5	184.1	13.5	12	34.925	85.850	7.938	38.443	144.5
250	226	215.9	22.0	5.5	184.1	13.5	12	41.275	101.600	9.525	45.491	144.5
280	285	266.7	24.5	5.5	228.6	13.5	22.0	47.625	117.602	12.70	53.111	157.5
320	340	317.5	26.5	5.5	279.4	17.0	32.5	53.975	133.350	12.70	59.563	232.0
360	340	317.5	26.5	5.5	279.4	17.0	34.5	60.325	149.352	15.875	67.208	253.0

SIMOGEAR Gearboxes

Parallel shaft gearbox with adapter K3

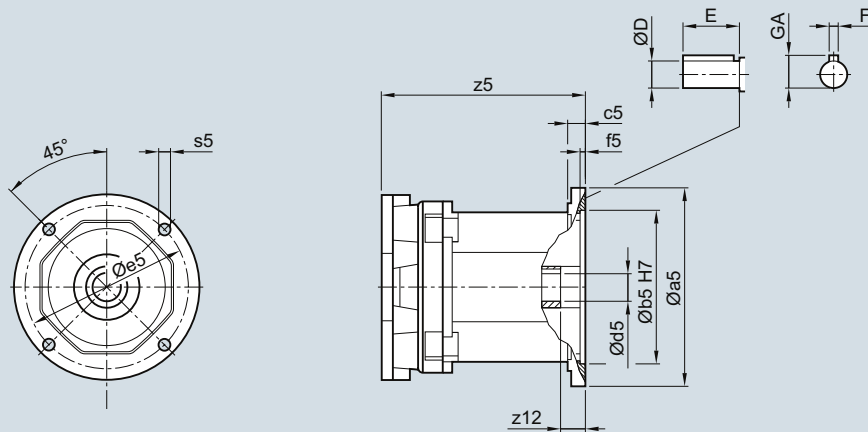
Dimensions**FD.../FZ...29 to FD.../FZ...89 gearboxes****F.AD.030K3, F.Z.030K3, F.F.030K3, F..030K3**

Adapter	a5	b5	c5	f5	e5	s5	z12	d5/D	E	F	GA	z5
FD.../FZ...29												
56	168	114.3	15	5.0	149.2	11.0	27.5	15.875	47.752	4.763	17.895	201.0
140	168	114.3	15	5.0	149.2	11.0	28.0	22.225	57.150	4.763	24.346	201.0
180	226	215.9	22	5.5	184.1	13.5	42.0	28.575	69.850	6.350	31.394	257.0
FD.../FZ...39												
56	168	114.3	15	5.0	149.2	11.0	27.5	15.875	47.752	4.763	17.895	201.0
140	168	114.3	15	5.0	149.2	11.0	28.0	22.225	57.150	4.763	24.346	201.0
180	226	215.9	22	5.5	184.1	13.5	42.0	28.575	69.850	6.350	31.394	257.0
FD.../FZ...49												
56	168	114.3	15	5.0	149.2	11.0	27.5	15.875	47.752	4.763	17.895	191.5
140	168	114.3	15	5.0	149.2	11.0	28.0	22.225	57.150	4.763	24.346	191.5
180	226	215.9	22	5.5	184.1	13.5	42.0	28.575	69.850	6.350	31.394	247.5
210	226	215.9	22	5.5	184.1	13.5	49.5	34.925	85.850	7.938	38.443	318.0
FD.../FZ...69												
56	168	114.3	15	5.0	149.2	11.0	27.5	15.875	47.752	4.763	17.895	191.5
140	168	114.3	15	5.0	149.2	11.0	28.0	22.225	57.150	4.763	24.346	191.5
180	226	215.9	22	5.5	184.1	13.5	42.0	28.575	69.850	6.350	31.394	247.5
210	226	215.9	22	5.5	184.1	13.5	49.5	34.925	85.850	7.938	38.443	318.0
FD.../FZ...79												
56	168	114.3	15	5.0	149.2	11.0	27.5	15.875	47.752	4.763	17.895	185.5
140	168	114.3	15	5.0	149.2	11.0	28.0	22.225	57.150	4.763	24.346	185.5
180	226	215.9	22	5.5	184.1	13.5	42.0	28.575	69.850	6.350	31.394	241.5
210	226	215.9	22	5.5	184.1	13.5	49.5	34.925	85.850	7.938	38.443	312.0
250	236	215.9	22	5.5	184.1	13.5	50.0	41.275	101.600	9.525	45.491	342.0
FD.../FZ...89												
140	168	114.3	15	5.0	149.2	11.0	28.0	22.225	57.150	4.763	24.346	172.5
180	226	215.9	22	5.5	184.1	13.5	42.0	28.575	69.850	6.350	31.394	224.5
210	226	215.9	22	5.5	184.1	13.5	49.5	34.925	85.850	7.938	38.443	295.0
250	236	215.9	22	5.5	184.1	13.5	55.5	41.275	101.600	9.525	45.491	325.0

FD.../FZ...109 to FD.../FZ...189 gearboxes

F.AD.030K3, F.Z.030K3, F.F.030K3, F.030K3

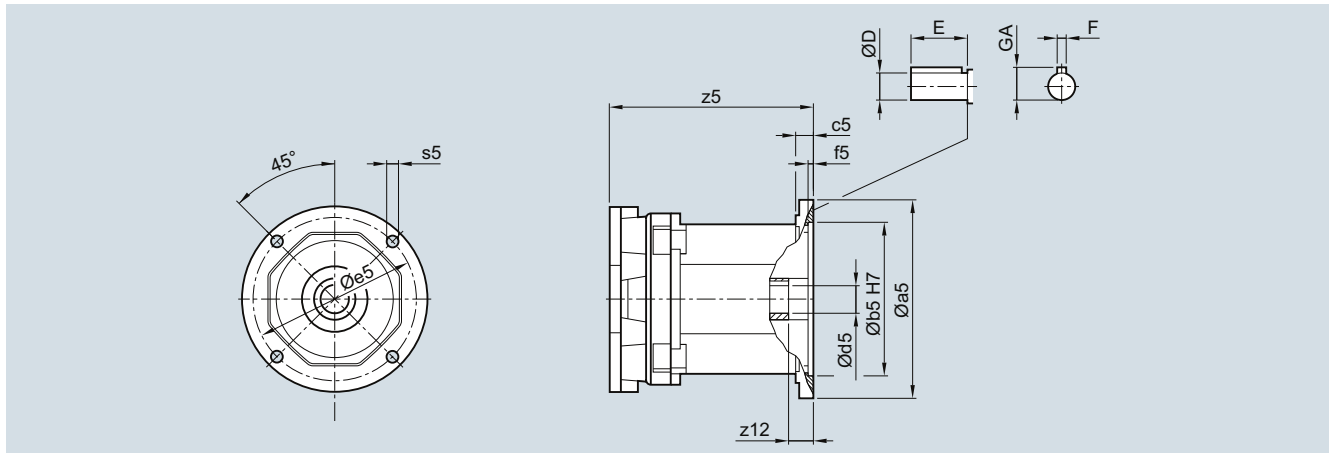

Adapter	a5	b5	c5	f5	e5	s5	z12	d5/D	E	F	GA	z5
FD.../FZ...109												
140	168	114.3	15	5.0	149.2	11.0	28.0	22.225	57.150	4.763	24.346	172.5
180	226	215.9	22	5.5	184.1	13.5	42.0	28.575	69.850	6.350	31.394	224.5
210	226	215.9	22	5.5	184.1	13.5	49.5	34.925	85.850	7.938	38.443	295.0
250	236	215.9	22	5.5	184.1	13.5	55.5	41.275	101.600	9.525	45.491	325.0
280	285	266.7	24.5	5.5	228.6	13.5	66.5	47.625	117.602	12.7	53.111	334.0
320	340	317.5	26.5	5.5	279.4	17.0	76.5	53.975	133.350	12.7	59.563	411.5
FD.../FZ...129												
140	168	114.3	15	5.0	149.2	11.0	28.0	22.225	57.150	4.763	24.346	158.5
180	226	215.9	22	5.5	184.1	13.5	42.0	28.575	69.850	6.350	31.394	206.5
210	226	215.9	22	5.5	184.1	13.5	49.5	34.925	85.850	7.938	38.443	275.0
250	236	215.9	22	5.5	184.1	13.5	55.5	41.275	101.600	9.525	45.491	302.0
280	285	266.7	24.5	5.5	228.6	13.5	66.5	47.625	117.602	12.7	53.111	323.0
320	340	317.5	26.5	5.5	279.4	17.0	76.5	53.975	133.350	12.7	59.563	406.5
360	340	317.5	26.5	5.5	279.4	17.0	83.5	60.325	149.352	15.875	67.21	454.0
FD.../FZ...149												
180	226	215.9	22	5.5	184.1	13.5	42.0	28.575	69.850	6.350	31.394	205.0
210	226	215.9	22	5.5	184.1	13.5	49.5	34.925	85.850	7.938	38.443	268.5
250	236	215.9	22	5.5	184.1	13.5	55.5	41.275	101.600	9.525	45.491	298.5
280	285	266.7	24.5	5.5	228.6	13.5	66.5	47.625	117.602	12.7	53.111	316.5
320	340	317.5	26.5	5.5	279.4	17.0	76.5	53.975	133.350	12.7	59.563	394.5
360	340	317.5	26.5	5.5	279.4	17.0	83.5	60.325	149.352	15.875	67.21	447.5
FD.../FZ...169												
210	226	215.9	22	5.5	184.1	13.5	49.5	34.925	85.850	7.938	38.443	255.5
250	236	215.9	22	5.5	184.1	13.5	55.5	41.275	101.600	9.525	45.491	285.5
280	285	266.7	24.5	5.5	228.6	13.5	66.5	47.625	117.602	12.7	53.111	303.5
320	340	317.5	26.5	5.5	279.4	17.0	76.5	53.975	133.350	12.7	59.563	379.5
360	340	317.5	26.5	5.5	279.4	17.0	83.5	60.325	149.352	15.875	67.21	429.0
FD.../FZ...189												
210	226	215.9	22	5.5	184.1	13.5	49.5	34.925	85.850	7.938	38.443	255.5
250	236	215.9	22	5.5	184.1	13.5	55.5	41.275	101.600	9.525	45.491	285.5
280	285	266.7	24.5	5.5	228.6	13.5	66.5	47.625	117.602	12.7	53.111	303.5
320	340	317.5	26.5	5.5	279.4	17.0	76.5	53.975	133.350	12.7	59.563	379.5
360	340	317.5	26.5	5.5	279.4	17.0	83.5	60.325	149.352	15.875	67.21	429.0

SIMOGEAR Gearboxes

Parallel shaft gearboxes

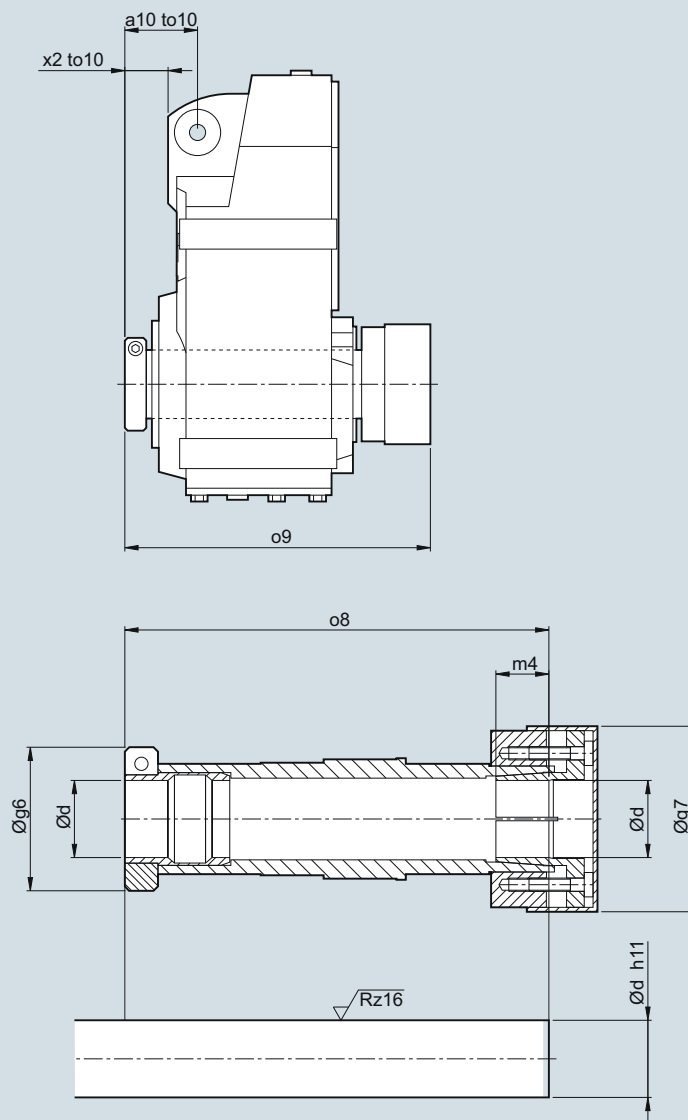
Dimensions**SIMOLOC assembly system****FDADR/FZADR**

Note mounting tolerance to10 when positioning the torque arm.

SIMOLOC assembly system (continued)

d	g6	g7	m4	o8	o9	a10	to10	x2
FDADR/FZADR29								
25	58.5	56	18.5	140.5	161	40.0	+2.1	23.5
20							+0.6	
1"								
0.75"								
FDADR/FZADR39								
30	62.0	76	22	160.5	181	46.5	+2.2	29.5
25							+0.7	
1.25"								
1.1875"								
1"								
FDADR/FZADR49								
35	65.0	84	24	192.0	214	47.0	+2.6	24.5
30							+0.8	
1.375"								
1.4375"								
1.25"								
1.1875"								
FDADR/FZADR.69								
40	79.5	94	30	217.5	240	59.5	+2.5	37.0
35							+0.7	
1.5"								
1.625"								
1.4375"								
1.375"								
FDADR/FZADR79								
40	79.5	94	30	232.0	259	60.0	+3.2	34.0
35							+1.4	
1.5"								
1.625"								
1.4375"								
1.375"								
FDADR/FZADR89								
50	89.0	114	32	264.0	295	69.0	+3.4	32.0
40							+1.5	
2"								
1.9375"								
1.75"								
1.625"								

SIMOGEAR Gearboxes

Parallel shaft gearboxes

Dimensions

Protection cover for hollow shaft

F.A.S, F.AFS, F.AZS, F.ADS

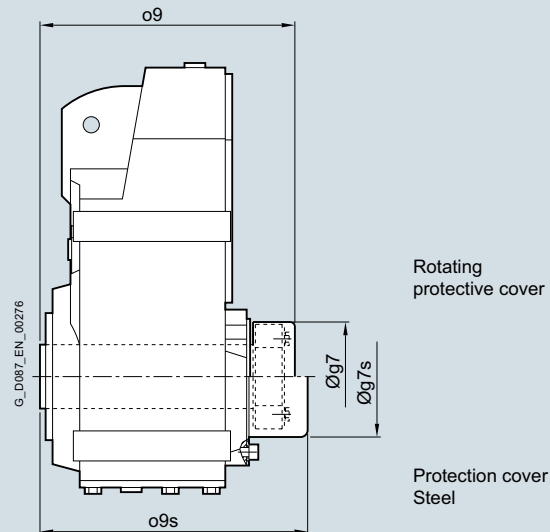

Protection cover for hollow shaft and hollow shaft with shrink disk

Gearbox type	F.A..29	F.A..39	F.A..49	F.A..69	F.A..79	F.A..89	F.A..109	F.A..129	F.A..149	F.A..169	F.A..189
Rotating protective cover with shrink disk version											
max. motor size that can be mounted	80	90	100	100	132	160	200	225	250	250	250
g7	57.0	76.0	84.0	84.0	94.0	119.0	142.0	159.0	201.0	234.0	267.0
o9	132.5	149.5	182.0	198.0	215.5	247.5	282.5	348.5	408.5	496.0	593.5
Protection cover											
max. motor size that can be mounted	71	80	100	100	112	132	200	225	250	250	250
g7s	58.0	86.0	86.0	99.0	99.0	137.0	186.8	186.8	217.8	257.5	309.5
o9s	135.5	170.0	198.0	210.0	223.5	284.5	308.5	375.0	425.0	520.0	621.5

F.ADR

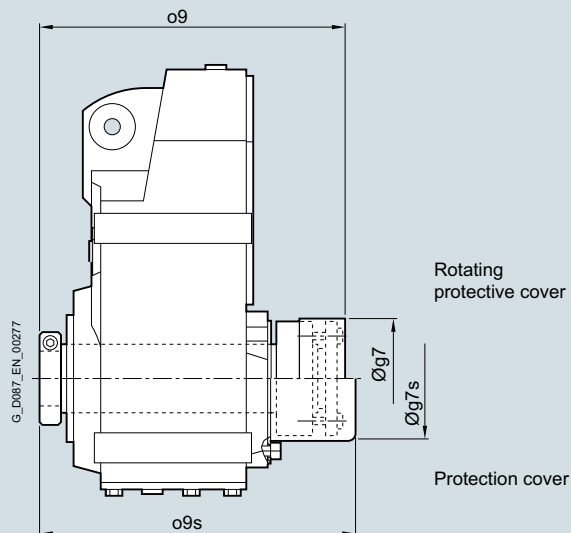

Protection cover for hollow shaft with SIMOLOC assembly system

Gearbox type	F.ADR29	F.ADR39	F.ADR49	F.ADR69	F.ADR79	F.ADR89
Rotating protective cover						
max. motor size that can be mounted	80	90	100	100	132	160
g7	56	76	84	94	94	114
o9	161	181	214	240	259	295
Protection cover						
max. motor size that can be mounted	71	80	100	100	112	132
g7s	58	82.5	86	99	99	137
o9s	164	184.0	217	243	262	298

Inner contour of the flange design

Notes regarding the design of the customer's interface, e.g. plug-in shaft for hollow shaft design

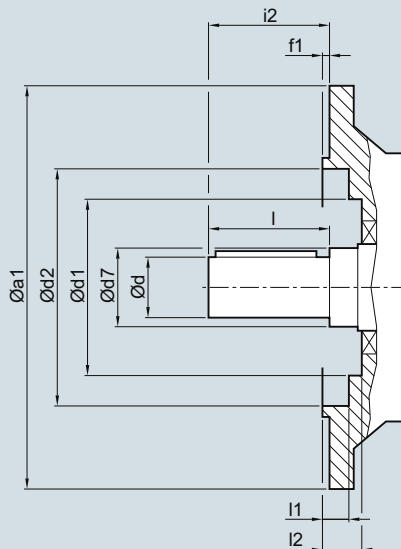
FDF/FZF

Gearbox type	a1	d	d7	d1	d2	f1	i2	l	l1	l2
FDF/FZF29	120	20	40	-	70	3.0	40	40	24.0	-
	160	20	40	70	101	3.5	40	40	8.5	24.5
FDF/FZF39	160	25	30	-	100	3.5	50	50	5.0	-
FDF/FZF49	200	30	35	-	118	3.5	60	60	5.5	-
FDF/FZF69	250	35	45	-	165	4.0	70	70	6.5	-
FDF/FZF79	250	40	55	-	165	4.0	80	80	6.5	-
FDF/FZF89	300	50	55	-	165	4.0	100	100	8.0	-
FDF/FZF109	350	60	65	-	235	5.0	120	120	9.0	-
FDF/FZF129	450	70	75	-	336	5.0	140	140	9.0	-
FDF/FZF149	450	90	100	-	336	5.0	170	170	10.0	-
FDF/FZF169	550	110	120	-	427	5.0	210	210	10.0	-
FDF/FZF189	660	120	160	-	517	6.0	210	210	11.0	-

SIMOGEAR Gearboxes

Parallel shaft gearboxes

Dimensions

Inner contour of the flange design (continued)

Notes regarding the design of the customer's interface, e.g. plug-in shaft for hollow shaft design

FDAF./FZAF.

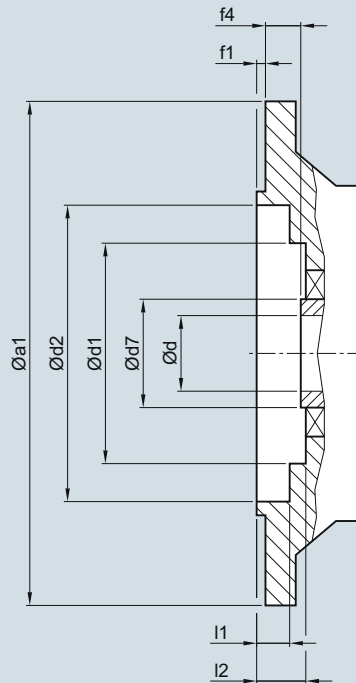

Gearbox type	a1	d	d7	d1	d2	f1	f4	l1	l2
FDAF./FZAF.29	120	25	40	-	70	3.0	20.0	24.0	-
	160	25	40	70	101	3.5	20.0	8.5	24.5
FDAF./FZAF.39	160	30	45	80	102	3.5	24.0	2.0	29.5
FDAF./FZAF.49	200	35	50	90	120	3.5	25.0	4.0	30.5
FDAF./FZAF.69	250	40	55	104	165	4.0	23.5	2.0	29.5
FDAF./FZAF.79	250	40	55	104	165	4.0	23.0	2.0	29.5
FDAF./FZAF.89	300	50	70	135	215	4.0	37.0	2.0	44.5
FDAF./FZAF.109	350	60	85	184	210	5.0	36.0	13.0	45.0
FDAF./FZAF.129	450	70	95	184	336	5.0	41.5	16.5	48.5
FDAF./FZAF.149	450	90	120	214	330	5.0	41.0	10.5	50.0
FDAF./FZAF.169	550	100	140	254	426	5.0	56.0	14.5	56.0
FDAF./FZAF.189	660	120	160	306	518	6.0	66.0	6.0	62.0

Pin holes

In the case of gearboxes F.Z.109 and F.Z.129, the customer's interface can be pinned on the housing flange (C type).

The output flanges have been designed to ensure the reliable transmission of the permissible torques and radial forces by the bolt connections.

If additional fastening is required, in the case of high shock loads, for example, the existing drilled pin holes can be used.

The gearboxes can also be drilled and pinned together with the machine. The listed dimensions must be complied with.

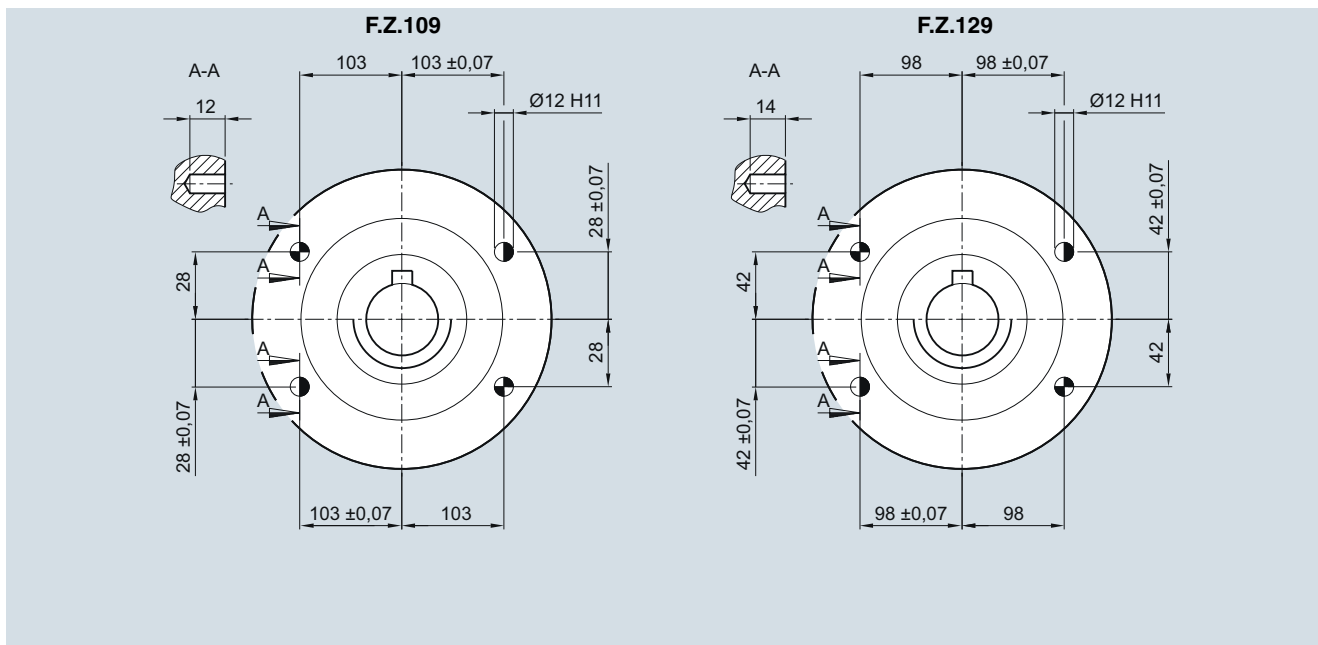

- Spring pins, heavy-duty design, to DIN 1481: Use pin holes provided in the housing flange.
- Grooved cylindrical pins with chamfer to EN 28740/ISO 8740: Drill connecting component together with housing.

SIMOGEAR Gearboxes

Notes

4

Bevel Gearboxes

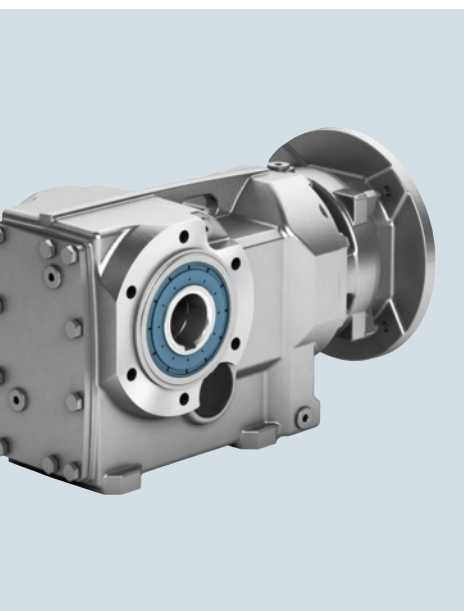

5/2	Orientation	5/74	Dimensions (continued)
5/3	Transmission ratios and torques		<u>Bevel gearbox with adapter KQ</u>
5/3	Selection and ordering data	5/74	B..29
5/16	Dimensions	5/75	B.F.29
5/16	Dimensional drawing overview	5/76	B.Z.29
	<u>Bevel gearbox with adapter K4</u>	5/77	BAD.29
5/19	B..29	5/78	B..39
5/20	B.F.29	5/79	B.F.39
5/21	B.Z.29	5/80	B.Z.39
5/22	BAD.29	5/81	BAD.39
5/23	B..39	5/82	B..49
5/24	B.F.39	5/83	B.F.49
5/25	B.Z.39	5/84	B.Z.49
5/26	BAD.39	5/85	BAD.49
5/27	B..49	5/86	K..39
5/28	B.F.49	5/87	K.F.39
5/29	B.Z.49	5/88	K.Z.39
5/30	BAD.49	5/89	KAD.39
5/31	K..39	5/90	K..49
5/32	K.F.39	5/91	K.F.49
5/33	K.Z.39	5/92	K.Z.49
5/34	KAD.39	5/93	KAD.49
5/35	K..49	5/94	K..69
5/36	K.F.49	5/95	K.F.69
5/37	K.Z.49	5/96	K.Z.69
5/38	KAD.49	5/97	KAD.69
5/39	K..69	5/98	K..79
5/40	K.F.69	5/99	K.F.79
5/41	K.Z.69	5/100	K.Z.79
5/42	KAD.69	5/101	KAD.79
5/43	K..79	5/102	K..89
5/44	K.F.79	5/103	K.F.89
5/45	K.Z.79	5/104	K.Z.89
5/46	KAD.79	5/105	KAD.89
5/47	K..89	5/106	K..109
5/48	K.F.89	5/107	K.F.109
5/49	K.Z.89	5/108	K.Z.109
5/50	KAD.89	5/109	KA.109
5/51	K..109	5/110	K..129
5/52	K.F.109	5/111	K.F.129
5/53	K.Z.109	5/112	K.Z.129
5/54	KA.109	5/113	KAD.129
5/55	K..129	5/114	K..149
5/56	K.F.129	5/115	K.F.149
5/57	K.Z.129	5/116	K.Z.149
5/58	KAD.129	5/117	KAD.149
5/59	K..149	5/118	K..169
5/60	K.F.149	5/119	K.F.169
5/61	K.Z.149	5/120	K.Z.169
5/62	KAD.149	5/121	KAD.169
5/63	K..169	5/122	K..189
5/64	K.F.169	5/123	K.F.189
5/65	K.Z.169	5/124	K.Z.189
5/66	KAD.169	5/125	KAD.189
5/67	K..189	5/126	<u>Bevel gearbox with adapter KQS</u>
5/68	K.F.189		B..29 bis B..49 und K..39 bis K..189
5/69	K.Z.189	5/128	<u>Bevel gearbox with adapter K8</u>
5/70	KAD.189		B..39 bis B..49 und K..39 bis K..189
	<u>Bevel gearbox with adapter K2</u>	5/130	<u>Bevel gearbox with adapter K5</u>
5/71	B..29 bis B..49 und K..39 bis K..189		B..29 bis B..49 und K..39 bis K..189
		5/132	<u>Bevel gearbox with adapter K3</u>
			B..29 to B..49 and K..39 to K..189
		5/134	SIMOLOC assembly system
		5/136	Protection cover for hollow shaft
		5/137	Inner contour of the flange design
		5/139	Pin holes

SIMOGEAR Gearboxes

Bevel gearboxes

Orientation

SIMOGEAR bevel gearbox B

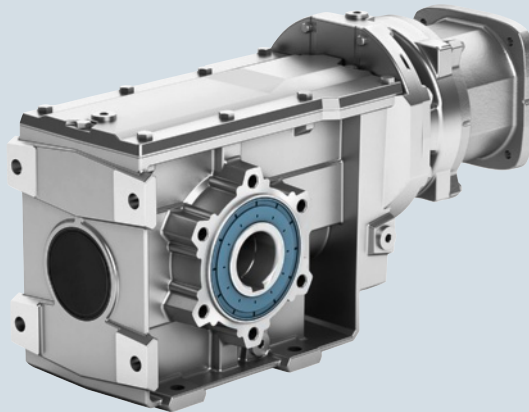

Fig. 5/1 Bevel gearbox B

Gearbox designation	Number of sizes	Maximum output torque	Transmission ratio	Maximum motor power
		T_{2N} Nm	i -	P_1 kW
B29 ... B49 (2-stage)	3	50... 450	3.5 ... 59	9.2

SIMOGEAR bevel gearbox K

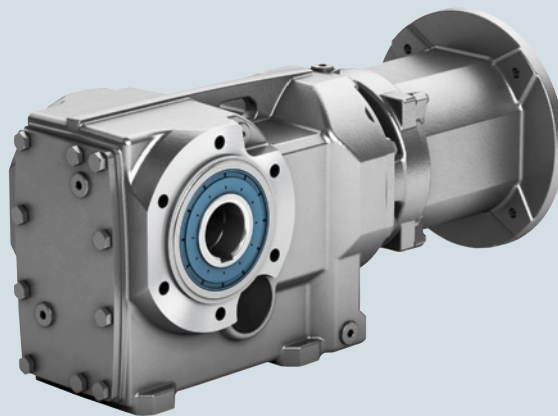

Fig. 5/2 Bevel gearbox K

Gearbox designation	Number of sizes	Maximum output torque	Transmission ratio	Maximum motor power
		T_{2N} Nm	i -	P_1 kW
K39 ... K189 (3-stage)	10	150 ... 19 500	5.7 ... 237	200

SIMOGEAR bevel gearboxes are available in the following versions for mounting in any position:

- 2 or 3 stages
- Shaft-mounted design with torque arm
- Flange-mounted design
- Design with integrated housing flange
- Foot-mounted design
- Hollow-shaft design with feather key, splined shaft or shrink disk
- Solid shaft design with and without feather key (at one end or both ends)

For 2-stage bevel gearboxes B, the torque arm is supplied loose to enable it to be mounted as required on site. The position of the torque arm can be freely selected.

Selection and ordering data (continued)

Gearbox							Adapter													Article No.				
i	n ₂	T _{2N}	F _{R2}	φ ¹⁾	J _G	R _{ex}	K4	63	71	80	90	100	112	132	160	180	200	225	250	280	315	→ below)		
-	rpm	Nm	N	'	10 ⁻⁴	-	K2			80	90	100	112	132	160	180	200	225	250					
							KQ	703	704	706			708	710										
							K8						808	810		813		816		818	822			
							K5	56		140	180			210	250			280	320	360				
							K3	56		140	180			210	250			280	320	360				

B.29

46.85	31	110	4 130	13	0.04	1265/27	✓	✓															2KJ3501 - ■ ■ A 0 ■ - 0 ■ B2
41.56	35	110	4 130	13	0.05	374/9	✓	✓	✓														2KJ3501 - ■ ■ A 0 ■ - 0 ■ A2
36.06	40	110	4 130	13	0.06	649/18	✓	✓	✓														2KJ3501 - ■ ■ A 0 ■ - 0 ■ X1
32.78	44	110	4 130	13	0.07	295/9	✓	✓	✓	✓													2KJ3501 - ■ ■ A 0 ■ - 0 ■ W1
28.11	52	110	4 130	13	0.09	253/9	✓	✓	✓	✓													2KJ3501 - ■ ■ A 0 ■ - 0 ■ V1
25.56	57	110	4 130	13	0.11	230/9	✓	✓	✓	✓													2KJ3501 - ■ ■ A 0 ■ - 0 ■ U1
22.41	65	110	4 130	14	0.13	605/27	✓	✓	✓	✓	✓												2KJ3501 - ■ ■ A 0 ■ - 0 ■ T1
20.00	72	110	4 130	14	0.16	20/1	✓	✓	✓	✓	✓												2KJ3501 - ■ ■ A 0 ■ - 0 ■ S1
17.82	81	110	4 130	14	0.19	1925/108	✓	✓	✓	✓	✓												2KJ3501 - ■ ■ A 0 ■ - 0 ■ R1
16.45	88	110	4 130	14	0.23	1925/117	✓	✓	✓	✓	✓												2KJ3501 - ■ ■ A 0 ■ - 0 ■ Q1
14.40	101	110	4 020	14	0.28	605/42	✓	✓	✓	✓	✓												2KJ3501 - ■ ■ A 0 ■ - 0 ■ P1
12.63	115	110	3 800	14	0.27	341/27	✓	✓	✓	✓	✓												2KJ3501 - ■ ■ A 0 ■ - 0 ■ N1
11.46	127	110	3 650	15	0.38	275/24	✓	✓	✓	✓	✓												2KJ3501 - ■ ■ A 0 ■ - 0 ■ M1
10.78	135	110	3 560	15	0.44	550/51	✓	✓	✓	✓	✓												2KJ3501 - ■ ■ A 0 ■ - 0 ■ L1
9.51	152	110	3 370	14	0.50	770/81	✓	✓	✓	✓	✓												2KJ3501 - ■ ■ A 0 ■ - 0 ■ K1
8.25	176	110	3 170	14	0.67	33/4	✓	✓	✓	✓	✓												2KJ3501 - ■ ■ A 0 ■ - 0 ■ J1
7.84	185	75	3 350	20	0.41	345/44	✓	✓	✓	✓	✓												2KJ3501 - ■ ■ A 0 ■ - 0 ■ H1
7.38	196	75	3 270	20	0.48	1380/187	✓	✓	✓	✓	✓												2KJ3501 - ■ ■ A 0 ■ - 0 ■ G1
6.51	223	75	3 100	19	0.54	644/99	✓	✓	✓	✓	✓												2KJ3501 - ■ ■ A 0 ■ - 0 ■ F1
5.65	257	75	2 920	20	0.73	621/110	✓	✓	✓	✓	✓												2KJ3501 - ■ ■ A 0 ■ - 0 ■ E1
5.07	286	74	2 900	22	0.60	345/68	✓	✓	✓	✓	✓												2KJ3501 - ■ ■ A 0 ■ - 0 ■ D1
4.78	303	74	2 830	22	0.70	1380/289	✓	✓	✓	✓	✓												2KJ3501 - ■ ■ A 0 ■ - 0 ■ C1
4.21	344	74	2 690	22	0.82	644/153	✓	✓	✓	✓	✓												2KJ3501 - ■ ■ A 0 ■ - 0 ■ B1
3.65	397	73	2 550	22	1.10	621/170	✓	✓	✓	✓	✓												2KJ3501 - ■ ■ A 0 ■ - 0 ■ A1

¹⁾ Only in conjunction with reduced-backlash version

Article No. supplement		1 or 9																					
Shaft design	→ Page 9/39																						
Adapter size		K4	B	C	D	E	F	G	H	J	K	L	M	N									4
		K2			D	E	F	G	H	J	K	L	M	N	P	Q							2
		KQ	A	B	C			D	E														7
		K8						A	B		C		D		E	F							8
		K5	A		B	C			D	E		F	G	H									5
		K3	A		B	C			D	E		F	G	H									3
Adapter type																							
Gearbox mounting type	→ Page 9/34																						



SIMOGEAR Gearboxes

Bevel gearboxes

Transmission ratios and torques

Selection and ordering data (continued)

Gearbox							Adapter													Article No.				
i	n_2	T_{2N}	F_{R2}	ϕ ¹⁾	J_G	R_{ex}	K4	63	71	80	90	100	112	132	160	180	200	225	250	280	315	(Article No. supplement → below)		
-	rpm	Nm	N	'	10^{-4}	-	K2			80	90	100	112	132	160	180	200	225	250					
							KQ	703	704	706			708	710										
							K8						808	810		813		816		818	822			
							K5	56		140	180			210	250			280	320	360				
							K3	56		140	180			210	250			280	320	360				
B.39																								
56.36	26	250	6 980	10	0.06	4565/81	✓	✓															2KJ3502 - ■ ■ A 0 ■ - 0 ■ A2	
50.11	29	210	6 980	11	0.08	451/9	✓	✓	✓															2KJ3502 - ■ ■ A 0 ■ - 0 ■ X1
44.00	33	250	6 980	11	0.09	44/1	✓	✓	✓															2KJ3502 - ■ ■ A 0 ■ - 0 ■ W1
40.00	36	230	6 980	11	0.11	40/1	✓	✓	✓	✓														2KJ3502 - ■ ■ A 0 ■ - 0 ■ V1
34.22	42	250	6 980	11	0.13	308/9	✓	✓	✓	✓														2KJ3502 - ■ ■ A 0 ■ - 0 ■ U1
31.11	47	250	6 980	11	0.16	280/9	✓	✓	✓	✓														2KJ3502 - ■ ■ A 0 ■ - 0 ■ T1
27.50	53	250	6 980	11	0.20	55/2	✓	✓	✓	✓	✓	✓												2KJ3502 - ■ ■ A 0 ■ - 0 ■ S1
25.00	58	250	6 980	11	0.26	25/1	✓	✓	✓	✓	✓	✓	✓											2KJ3502 - ■ ■ A 0 ■ - 0 ■ R1
21.90	66	250	6 720	11	0.30	2365/108	✓	✓	✓	✓	✓	✓	✓											2KJ3502 - ■ ■ A 0 ■ - 0 ■ Q1
20.21	72	250	6 490	11	0.36	2365/117	✓	✓	✓	✓	✓	✓	✓											2KJ3502 - ■ ■ A 0 ■ - 0 ■ R1
17.90	81	250	6 160	11	0.43	2255/126	✓	✓	✓	✓	✓	✓	✓											2KJ3502 - ■ ■ A 0 ■ - 0 ■ Q1
14.90	97	250	5 680	11	0.58	715/48	✓	✓	✓	✓	✓	✓	✓											2KJ3502 - ■ ■ A 0 ■ - 0 ■ P1
14.02	103	250	5 530	11	0.67	715/51	✓	✓	✓	✓	✓	✓	✓											2KJ3502 - ■ ■ A 0 ■ - 0 ■ N1
12.56	115	250	5 260	12	0.75	2035/162	✓	✓	✓	✓	✓	✓	✓											2KJ3502 - ■ ■ A 0 ■ - 0 ■ M1
10.69	136	240	4 960	12	0.98	385/36	✓	✓	✓	✓	✓	✓	✓											2KJ3502 - ■ ■ A 0 ■ - 0 ■ L1
9.17	158	230	4 700	12	1.29	55/6			✓	✓	✓	✓	✓											2KJ3502 - ■ ■ A 0 ■ - 0 ■ K1
7.89	184	220	4 550	12	1.66	1705/216			✓	✓	✓	✓	✓											2KJ3502 - ■ ■ A 0 ■ - 0 ■ J1
6.60	220	200	4 590	18	0.94	897/136	✓	✓	✓	✓	✓	✓	✓											2KJ3502 - ■ ■ A 0 ■ - 0 ■ H1
6.21	233	200	4 550	18	1.08	1794/289	✓	✓	✓	✓	✓	✓	✓											2KJ3502 - ■ ■ A 0 ■ - 0 ■ G1
5.56	261	200	4 460	18	1.26	851/153	✓	✓	✓	✓	✓	✓	✓											2KJ3502 - ■ ■ A 0 ■ - 0 ■ F1
4.74	306	200	4 330	19	1.69	161/34	✓	✓	✓	✓	✓	✓	✓											2KJ3502 - ■ ■ A 0 ■ - 0 ■ E1
4.06	357	200	4 190	20	2.30	69/17			✓	✓	✓	✓	✓											2KJ3502 - ■ ■ A 0 ■ - 0 ■ D1
3.50	414	192	4 050	20	3.00	713/204			✓	✓	✓	✓	✓											2KJ3502 - ■ ■ A 0 ■ - 0 ■ A1

1) Only in conjunction with reduced-backlash version

Article No. supplement

Shaft design → Page 9/39

Adapter size

	1 or 9																							
K4	B	C	D	E	F	G	H	J	K	L	M	N											4	
K2			D	E	F	G	H	J	K	L	M	N	P	Q										2
KQ	A	B	C			D	E																	7
K8						A	B		C		D		E	F										8
K5	A		B	C		D	E		F	G	H													5
K3	A		B	C		D	E		F	G	H													3

Adapter type

Gearbox mounting type → Page 9/34

A, B, F or H

Selection and ordering data (continued)

Gearbox							Adapter														Article No.	
i	n_2	T_{2N}	F_{R2}	ϕ ¹⁾	J_G	R_{ex}	K4	63	71	80	90	100	112	132	160	180	200	225	250			(Article No. supplement → below)
-	rpm	Nm	N	'	10^{-4}	-	K2			80	90	100	112	132	160	180	200	225	250	280	315	
							KQ	703	704	706			708	710								
							K8						808	810		813		816		818	822	
							K5	56		140	180			210	250			280	320	360		
							K3	56		140	180			210	250			280	320	360		

B.49																						
59.28	24	450	9 510	9	0.19	1067/18	✓	✓	✓													2KJ3503 - ■■ A 0 ■ - 0 ■ C2
53.89	27	450	9 120	9	0.23	485/9	✓	✓	✓	✓												2KJ3503 - ■■ A 0 ■ - 0 ■ B2
45.83	32	450	8 480	9	0.28	275/6	✓	✓	✓	✓												2KJ3503 - ■■ A 0 ■ - 0 ■ A2
41.67	35	450	8 120	9	0.34	125/3	✓	✓	✓	✓												2KJ3503 - ■■ A 0 ■ - 0 ■ X1
37.18	39	450	7 710	9	0.40	4015/108	✓	✓	✓	✓	✓	✓										2KJ3503 - ■■ A 0 ■ - 0 ■ W1
33.33	44	450	7 330	9	0.48	100/3	✓	✓	✓	✓	✓	✓										2KJ3503 - ■■ A 0 ■ - 0 ■ V1
30.05	48	450	6 980	9	0.56	3245/108	✓	✓	✓	✓	✓	✓										2KJ3503 - ■■ A 0 ■ - 0 ■ U1
27.74	52	450	6 710	9	0.67	3245/117	✓	✓	✓	✓	✓	✓										2KJ3503 - ■■ A 0 ■ - 0 ■ T1
25.32	57	450	6 420	9	0.80	1595/63	✓	✓	✓	✓	✓	✓	✓									2KJ3503 - ■■ A 0 ■ - 0 ■ S1
21.01	69	450	5 850	10	1.03	3025/144	✓	✓	✓	✓	✓	✓	✓									2KJ3503 - ■■ A 0 ■ - 0 ■ R1
19.77	73	450	5 680	10	1.18	3025/153	✓	✓	✓	✓	✓	✓	✓									2KJ3503 - ■■ A 0 ■ - 0 ■ Q1
18.67	78	450	5 510	10	1.34	3025/162	✓	✓	✓	✓	✓	✓	✓									2KJ3503 - ■■ A 0 ■ - 0 ■ P1
15.89	91	450	5 070	10	1.66	143/9	✓	✓	✓	✓	✓	✓	✓									2KJ3503 - ■■ A 0 ■ - 0 ■ N1
13.61	107	450	4 660	10	2.10	245/18			✓	✓	✓	✓	✓									2KJ3503 - ■■ A 0 ■ - 0 ■ M1
11.97	121	450	4 340	10	2.50	2585/216			✓	✓	✓	✓	✓									2KJ3503 - ■■ A 0 ■ - 0 ■ L1
10.10	144	450	3 940	10	3.30	2090/207			✓	✓	✓	✓	✓									2KJ3503 - ■■ A 0 ■ - 0 ■ K1
8.80	165	450	3 630	11	4.40	44/5			✓	✓	✓	✓	✓									2KJ3503 - ■■ A 0 ■ - 0 ■ J1
8.29	175	330	4 550	16	1.52	2255/272	✓	✓	✓	✓	✓	✓	✓									2KJ3503 - ■■ A 0 ■ - 0 ■ H1
7.80	186	330	4 420	16	1.74	2255/289	✓	✓	✓	✓	✓	✓	✓									2KJ3503 - ■■ A 0 ■ - 0 ■ G1
7.37	197	330	4 300	16	1.97	2255/306	✓	✓	✓	✓	✓	✓	✓									2KJ3503 - ■■ A 0 ■ - 0 ■ F1
6.27	231	330	3 970	16	2.50	533/85	✓	✓	✓	✓	✓	✓	✓									2KJ3503 - ■■ A 0 ■ - 0 ■ E1
5.37	270	330	3 700	17	3.30	2009/374			✓	✓	✓	✓	✓									2KJ3503 - ■■ A 0 ■ - 0 ■ D1
4.72	307	330	3 690	17	4.10	1927/408			✓	✓	✓	✓	✓									2KJ3503 - ■■ A 0 ■ - 0 ■ C1
3.98	364	330	3 660	17	5.40	1558/391			✓	✓	✓	✓	✓									2KJ3503 - ■■ A 0 ■ - 0 ■ B1
3.47	418	325	3 610	9	7.20	1476/425			✓	✓	✓	✓	✓									2KJ3503 - ■■ A 0 ■ - 0 ■ A1

¹⁾ Only in conjunction with reduced-backlash version

Article No. supplement		1 or 9																				
Shaft design	→ Page 9/39	B	C	D	E	F	G	H	J	K	L	M	N									4
Adapter size				D	E	F	G	H	J	K	L	M	N	P	Q							2
		A	B	C		D	E															7
						A	B		C		D		E	F								8
		A		B	C		D	E		F	G	H										5
		A		B	C		D	E		F	G	H										3
Adapter type																						
Gearbox mounting type	→ Page 9/34	A, B, F or H																				

SIMOGEAR Gearboxes

Bevel gearboxes

Transmission ratios and torques

Selection and ordering data (continued)

Gearbox							Adapter													Article No.		
i	n_2	T_{2N}	F_{R2}	ϕ ¹⁾	J_G	R_{ex}	K4	63	71	80	90	100	112	132	160	180	200	225	250	280	315	(Article No. supplement → below)
-	rpm	Nm	N	'	10 ⁻⁴	-	K2			80	90	100	112	132	160	180	200	225	250			
							KQ	703	704	706			708	710								
							K8						808	810		813		816		818	822	
							K5	56		140	180		210	250			280	320	360			
							K3	56		140	180		210	250			280	320	360			
K.39																						
157.32	9.2	220	6 080	10	0.04	3933/25	✓	✓														2KJ3504 - ■ A 0 ■ - 0 ■ J2
139.54	10	220	6 080	10	0.05	17442/125	✓	✓	✓													2KJ3504 - ■ A 0 ■ - 0 ■ H2
121.07	12	220	6 080	10	0.06	30267/250	✓	✓	✓													2KJ3504 - ■ A 0 ■ - 0 ■ G2
110.06	13	220	6 080	10	0.07	30267/275	✓	✓	✓	✓												2KJ3504 - ■ A 0 ■ - 0 ■ F2
94.39	15	220	6 080	10	0.08	11799/125	✓	✓	✓	✓												2KJ3504 - ■ A 0 ■ - 0 ■ E2
85.81	17	220	6 080	10	0.11	23598/275	✓	✓	✓	✓												2KJ3504 - ■ A 0 ■ - 0 ■ D2
75.24	19	220	6 080	10	0.12	1881/25	✓	✓	✓	✓	✓	✓										2KJ3504 - ■ A 0 ■ - 0 ■ C2
67.16	22	220	6 080	10	0.15	18468/275	✓	✓	✓	✓	✓	✓	✓									2KJ3504 - ■ A 0 ■ - 0 ■ B2
59.85	24	220	6 080	10	0.18	1197/20	✓	✓	✓	✓	✓	✓	✓									2KJ3504 - ■ A 0 ■ - 0 ■ A2
55.25	26	220	6 080	10	0.22	3591/65	✓	✓	✓	✓	✓	✓	✓									2KJ3504 - ■ A 0 ■ - 0 ■ X1
48.37	30	220	6 080	10	0.26	16929/350	✓	✓	✓	✓	✓	✓	✓									2KJ3504 - ■ A 0 ■ - 0 ■ W1
42.41	34	220	5 790	10	0.24	5301/125	✓	✓	✓	✓	✓	✓	✓									2KJ3504 - ■ A 0 ■ - 0 ■ V1
38.47	38	220	5 540	10	0.34	1539/40	✓	✓	✓	✓	✓	✓	✓									2KJ3504 - ■ A 0 ■ - 0 ■ U1
36.21	40	220	5 390	10	0.40	3078/85	✓	✓	✓	✓	✓	✓	✓									2KJ3504 - ■ A 0 ■ - 0 ■ T1
31.92	45	220	5 090	10	0.44	798/25	✓	✓	✓	✓	✓	✓	✓									2KJ3504 - ■ A 0 ■ - 0 ■ S1
27.70	52	220	4 760	10	0.60	13851/500	✓	✓	✓	✓	✓	✓	✓									2KJ3504 - ■ A 0 ■ - 0 ■ R1
26.89	54	220	4 690	12	0.26	6804/253	✓	✓	✓	✓	✓	✓	✓									2KJ3504 - ■ A 0 ■ - 0 ■ Q1
23.97	60	220	4 440	12	0.32	2205/92	✓	✓	✓	✓	✓	✓	✓									2KJ3504 - ■ A 0 ■ - 0 ■ P1
22.12	66	220	4 270	12	0.38	6615/299	✓	✓	✓	✓	✓	✓	✓									2KJ3504 - ■ A 0 ■ - 0 ■ N1
19.37	75	220	4 000	12	0.47	891/46	✓	✓	✓	✓	✓	✓	✓									2KJ3504 - ■ A 0 ■ - 0 ■ M1
16.98	85	220	3 740	12	0.51	1953/115	✓	✓	✓	✓	✓	✓	✓									2KJ3504 - ■ A 0 ■ - 0 ■ L1
15.41	94	220	3 560	12	0.67	2835/184	✓	✓	✓	✓	✓	✓	✓									2KJ3504 - ■ A 0 ■ - 0 ■ K1
14.50	100	220	3 450	12	0.78	5670/391	✓	✓	✓	✓	✓	✓	✓									2KJ3504 - ■ A 0 ■ - 0 ■ J1
12.78	113	220	3 220	12	0.92	294/23	✓	✓	✓	✓	✓	✓	✓									2KJ3504 - ■ A 0 ■ - 0 ■ H1
11.09	131	220	2 990	12	1.24	5103/460	✓	✓	✓	✓	✓	✓	✓									2KJ3504 - ■ A 0 ■ - 0 ■ G1
10.04	144	184	2 890	19	0.55	231/23	✓	✓	✓	✓	✓	✓	✓									2KJ3504 - ■ A 0 ■ - 0 ■ F1
8.81	165	183	2 790	19	0.62	3038/345	✓	✓	✓	✓	✓	✓	✓									2KJ3504 - ■ A 0 ■ - 0 ■ E1
7.99	181	175	2 810	19	0.80	735/92	✓	✓	✓	✓	✓	✓	✓									2KJ3504 - ■ A 0 ■ - 0 ■ D1
7.52	193	171	2 810	19	0.92	2940/391	✓	✓	✓	✓	✓	✓	✓									2KJ3504 - ■ A 0 ■ - 0 ■ C1
6.63	219	161	2 820	19	1.11	1372/207	✓	✓	✓	✓	✓	✓	✓									2KJ3504 - ■ A 0 ■ - 0 ■ B1
5.75	252	150	2 810	19	1.49	1323/230	✓	✓	✓	✓	✓	✓	✓									2KJ3504 - ■ A 0 ■ - 0 ■ A1

¹⁾ Only in conjunction with reduced-backlash version

Article No. supplement																							
Shaft design	→ Page 9/39	1 or 9																					
Adapter size		K4	B	C	D	E	F	G	H	J	K	L	M	N								4	
		K2			D	E	F	G	H	J	K	L	M	N	P	Q							2
		KQ	A	B	C		D	E															7
		K8					A	B		C		D	E	F									8
		K5		A	B	C		D	E		F	G	H										5
		K3		A	B	C		D	E		F	G	H										3
Adapter type																							
Gearbox mounting type	→ Page 9/34	A, B, F or H																					

Selection and ordering data (continued)

Gearbox							Adapter													Article No.		
i	n_2	T_{2N}	F_{R2}	ϕ ¹⁾	J_G	R_{ex}	K4	63	71	80	90	100	112	132	160	180	200	225	250	280	315	(Article No. supplement → below)
-	rpm	Nm	N	'	10 ⁻⁴	-	K2			80	90	100	112	132	160	180	200	225	250			
							KQ	703	704	706			708	710								
							K8						808	810		813		816		818	822	
							K5	56		140	180		210	250			280	320	360			
							K3	56		140	180		210	250			280	320	360			
K.49																						
200.25	7.2	420	7 820	8	0.06	12616/63	✓	✓														2KJ3505 - ■ A 0 ■ - 0 ■ J2
178.06	8.1	420	7 820	8	0.07	6232/35	✓	✓	✓													2KJ3505 - ■ A 0 ■ - 0 ■ H2
156.34	9.3	420	7 820	8	0.08	5472/35	✓	✓	✓													2KJ3505 - ■ A 0 ■ - 0 ■ G2
142.13	10	420	7 820	8	0.10	10944/77	✓	✓	✓	✓												2KJ3505 - ■ A 0 ■ - 0 ■ F2
121.60	12	420	7 820	8	0.12	608/5	✓	✓	✓	✓												2KJ3505 - ■ A 0 ■ - 0 ■ E2
110.55	13	420	7 820	8	0.14	1216/11	✓	✓	✓	✓												2KJ3505 - ■ A 0 ■ - 0 ■ D2
97.71	15	420	7 720	8	0.17	684/7	✓	✓	✓	✓	✓	✓										2KJ3505 - ■ A 0 ■ - 0 ■ C2
88.83	16	420	7 370	8	0.22	6840/77	✓	✓	✓	✓	✓	✓	✓									2KJ3505 - ■ A 0 ■ - 0 ■ B2
77.81	19	420	6 910	8	0.25	1634/21	✓	✓	✓	✓	✓	✓	✓									2KJ3505 - ■ A 0 ■ - 0 ■ A2
71.82	20	420	6 650	8	0.30	6536/91	✓	✓	✓	✓	✓	✓	✓									2KJ3505 - ■ A 0 ■ - 0 ■ X1
63.59	23	420	6 250	8	0.37	3116/49	✓	✓	✓	✓	✓	✓	✓	✓								2KJ3505 - ■ A 0 ■ - 0 ■ W1
52.93	27	420	5 680	8	0.50	741/14	✓	✓	✓	✓	✓	✓	✓	✓								2KJ3505 - ■ A 0 ■ - 0 ■ V1
49.82	29	420	5 510	8	0.58	5928/119	✓	✓	✓	✓	✓	✓	✓	✓								2KJ3505 - ■ A 0 ■ - 0 ■ U1
44.63	32	420	5 190	9	0.65	2812/63	✓	✓	✓	✓	✓	✓	✓	✓								2KJ3505 - ■ A 0 ■ - 0 ■ T1
38.00	38	420	4 750	9	0.84	38/1	✓	✓	✓	✓	✓	✓	✓	✓								2KJ3505 - ■ A 0 ■ - 0 ■ S1
32.57	45	420	4 350	9	1.11	228/7			✓	✓	✓	✓	✓	✓								2KJ3505 - ■ A 0 ■ - 0 ■ R1
28.05	52	420	3 970	9	1.43	589/21			✓	✓	✓	✓	✓	✓								2KJ3505 - ■ A 0 ■ - 0 ■ Q1
26.30	55	420	3 820	10	0.52	55040/2093	✓	✓	✓	✓	✓	✓	✓									2KJ3505 - ■ A 0 ■ - 0 ■ P1
23.28	62	420	3 540	11	0.65	26240/1127	✓	✓	✓	✓	✓	✓	✓	✓								2KJ3505 - ■ A 0 ■ - 0 ■ N1
19.38	75	420	3 130	11	0.90	3120/161	✓	✓	✓	✓	✓	✓	✓	✓								2KJ3505 - ■ A 0 ■ - 0 ■ M1
18.24	79	420	3 010	11	1.03	49920/2737	✓	✓	✓	✓	✓	✓	✓	✓								2KJ3505 - ■ A 0 ■ - 0 ■ L1
16.34	89	420	2 780	11	1.21	23680/1449	✓	✓	✓	✓	✓	✓	✓	✓								2KJ3505 - ■ A 0 ■ - 0 ■ K1
13.91	104	420	2 880	11	1.62	320/23	✓	✓	✓	✓	✓	✓	✓	✓								2KJ3505 - ■ A 0 ■ - 0 ■ J1
11.93	122	420	3 000	11	2.20	1920/161			✓	✓	✓	✓	✓	✓								2KJ3505 - ■ A 0 ■ - 0 ■ H1
10.27	141	415	3 080	11	2.90	4960/483			✓	✓	✓	✓	✓	✓								2KJ3505 - ■ A 0 ■ - 0 ■ G1
9.75	149	275	2 960	17	1.03	39/4	✓	✓	✓	✓	✓	✓	✓	✓								2KJ3505 - ■ A 0 ■ - 0 ■ F1
9.18	158	270	2 980	17	1.19	156/17	✓	✓	✓	✓	✓	✓	✓	✓								2KJ3505 - ■ A 0 ■ - 0 ■ E1
8.22	176	255	3 010	17	1.40	74/9	✓	✓	✓	✓	✓	✓	✓	✓								2KJ3505 - ■ A 0 ■ - 0 ■ D1
7.00	207	240	3 030	18	1.88	7/1	✓	✓	✓	✓	✓	✓	✓	✓								2KJ3505 - ■ A 0 ■ - 0 ■ C1
6.00	242	225	3 020	18	2.50	6/1			✓	✓	✓	✓	✓	✓								2KJ3505 - ■ A 0 ■ - 0 ■ B1
5.17	280	210	2 990	19	3.30	31/6			✓	✓	✓	✓	✓	✓								2KJ3505 - ■ A 0 ■ - 0 ■ A1

¹⁾ Only in conjunction with reduced-backlash version

Article No. supplement																							
Shaft design	→ Page 9/39	1 or 9																					
Adapter size		K4	B	C	D	E	F	G	H	J	K	L	M	N								4	
		K2			D	E	F	G	H	J	K	L	M	N	P	Q							2
		KQ	A	B	C		D	E														7	
		K8					A	B		C		D	E	F								8	
		K5		A	B	C		D	E		F	G	H									5	
		K3		A	B	C		D	E		F	G	H									3	
Adapter type																							
Gearbox mounting type	→ Page 9/34	A, B, F or H																					

SIMOGEAR Gearboxes

Bevel gearboxes

Transmission ratios and torques

Selection and ordering data (continued)

Gearbox								Adapter											Article No. (Article No. supplement → below)				
	i	n_2 rpm	T_{2N} Nm	F_{R2} N	ϕ ¹⁾	J_G 10^{-4} kgm ²	R_{ex}	K4	63	71	80	90	100	112	132	160	180	200		225	250	280	315
K.69																							
196.59	7.4	600	10 800	9	0.17	14744/75		✓	✓	✓													2KJ3507 - ■ ■ A 0 ■ - 0 ■ H2
178.72	8.1	600	10 800	9	0.20	29488/165		✓	✓	✓	✓												2KJ3507 - ■ ■ A 0 ■ - 0 ■ G2
152.00	9.5	600	10 800	9	0.25	152/1		✓	✓	✓	✓												2KJ3507 - ■ ■ A 0 ■ - 0 ■ F2
138.18	10	600	10 800	9	0.30	1520/11		✓	✓	✓	✓												2KJ3507 - ■ ■ A 0 ■ - 0 ■ E2
123.29	12	600	10 800	9	0.35	5548/45		✓	✓	✓	✓	✓	✓										2KJ3507 - ■ ■ A 0 ■ - 0 ■ D2
110.55	13	600	10 800	9	0.42	1216/11		✓	✓	✓	✓	✓	✓	✓									2KJ3507 - ■ ■ A 0 ■ - 0 ■ C2
99.64	15	600	10 800	9	0.49	4484/45		✓	✓	✓	✓	✓	✓	✓									2KJ3507 - ■ ■ A 0 ■ - 0 ■ B2
91.98	16	600	10 600	9	0.58	17936/195		✓	✓	✓	✓	✓	✓	✓									2KJ3507 - ■ ■ A 0 ■ - 0 ■ A2
83.96	17	600	10 100	9	0.69	8816/105		✓	✓	✓	✓	✓	✓	✓	✓								2KJ3507 - ■ ■ A 0 ■ - 0 ■ X1
69.67	21	600	9 300	9	0.87	209/3		✓	✓	✓	✓	✓	✓	✓	✓								2KJ3507 - ■ ■ A 0 ■ - 0 ■ W1
65.57	22	600	9 030	9	1.01	3344/51		✓	✓	✓	✓	✓	✓	✓	✓								2KJ3507 - ■ ■ A 0 ■ - 0 ■ V1
61.93	23	600	8 780	9	1.15	1672/27		✓	✓	✓	✓	✓	✓	✓	✓								2KJ3507 - ■ ■ A 0 ■ - 0 ■ U1
52.69	28	600	8 100	9	1.40	3952/75		✓	✓	✓	✓	✓	✓	✓	✓								2KJ3507 - ■ ■ A 0 ■ - 0 ■ T1
45.14	32	600	7 470	9	1.70	7448/165				✓	✓	✓	✓	✓	✓								2KJ3507 - ■ ■ A 0 ■ - 0 ■ S1
39.69	37	600	6 980	9	2.10	1786/45				✓	✓	✓	✓	✓	✓								2KJ3507 - ■ ■ A 0 ■ - 0 ■ R1
33.48	43	580	6 500	9	2.60	11552/345				✓	✓	✓	✓	✓	✓								2KJ3507 - ■ ■ A 0 ■ - 0 ■ Q1
29.18	50	555	6 200	9	3.50	3648/125				✓	✓	✓	✓	✓	✓								2KJ3507 - ■ ■ A 0 ■ - 0 ■ P1
26.05	56	600	5 510	11	1.25	3751/144		✓	✓	✓	✓	✓	✓	✓	✓								2KJ3507 - ■ ■ A 0 ■ - 0 ■ N1
24.52	59	595	5 350	11	1.44	3751/153		✓	✓	✓	✓	✓	✓	✓	✓								2KJ3507 - ■ ■ A 0 ■ - 0 ■ M1
23.15	63	585	5 240	11	1.63	3751/162		✓	✓	✓	✓	✓	✓	✓	✓								2KJ3507 - ■ ■ A 0 ■ - 0 ■ L1
19.70	74	555	4 960	11	2.10	4433/225		✓	✓	✓	✓	✓	✓	✓	✓								2KJ3507 - ■ ■ A 0 ■ - 0 ■ K1
16.88	86	530	4 690	11	2.60	1519/90				✓	✓	✓	✓	✓	✓								2KJ3507 - ■ ■ A 0 ■ - 0 ■ J1
14.84	98	515	4 440	11	3.30	16027/1080				✓	✓	✓	✓	✓	✓								2KJ3507 - ■ ■ A 0 ■ - 0 ■ H1
12.52	116	490	4 170	11	4.30	12958/1035				✓	✓	✓	✓	✓	✓								2KJ3507 - ■ ■ A 0 ■ - 0 ■ G1
10.91	133	470	3 970	12	5.70	1364/125				✓	✓	✓	✓	✓	✓								2KJ3507 - ■ ■ A 0 ■ - 0 ■ F1
9.34	155	370	3 640	16	2.40	3224/345		✓	✓	✓	✓	✓	✓	✓	✓								2KJ3507 - ■ ■ A 0 ■ - 0 ■ E1
8.01	181	365	3 330	16	3.10	6076/759				✓	✓	✓	✓	✓	✓								2KJ3507 - ■ ■ A 0 ■ - 0 ■ D1
7.04	206	365	3 210	16	3.90	1457/207				✓	✓	✓	✓	✓	✓								2KJ3507 - ■ ■ A 0 ■ - 0 ■ C1
5.94	244	345	3 350	17	5.10	9424/1587				✓	✓	✓	✓	✓	✓								2KJ3507 - ■ ■ A 0 ■ - 0 ■ B1
5.18	280	330	3 420	18	6.80	2976/575				✓	✓	✓	✓	✓	✓								2KJ3507 - ■ ■ A 0 ■ - 0 ■ A1

1) Only in conjunction with reduced-backlash version

Article No. supplement		1 or 9																					
Shaft design	→ Page 9/39																						
Adapter size		K4	B	C	D	E	F	G	H	J	K	L	M	N									4
		K2			D	E	F	G	H	J	K	L	M	N	P	Q							2
		KQ	A	B	C			D	E														7
		K8						A	B		C		D		E	F							8
		K5		A	B	C			D	E		F	G	H									5
		K3		A		B	C		D	E		F	G	H									3
Adapter type																							
Gearbox mounting type	→ Page 9/34		A, B, F or H																				

Selection and ordering data (continued)

Gearbox							Adapter													Article No.			
i	n ₂	T _{2N}	F _{R2}	φ ¹⁾	J _G	R _{ex}	K4	63	71	80	90	100	112	132	160	180	200	225	250	280	315	(Article No. supplement → below)	
-	rpm	Nm	N	'	10 ⁻⁴	-	K2			80	90	100	112	132	160	180	200	225	250				
							KQ	703	704	706			708	710									
							K8						808	810		813		816		818	822		
							K5	56		140	180			210	250			280	320	360			
							K3	56		140	180			210	250			280	320	360			
K.79																							
244.25	5.9	820	13 900	6	0.17	175861/720	✓	✓	✓														2KJ3508 - ■ ■ A 0 ■ - 0 ■ J2
222.05	6.5	820	13 900	6	0.20	175861/792	✓	✓	✓	✓													2KJ3508 - ■ ■ A 0 ■ - 0 ■ H2
188.85	7.7	820	13 900	6	0.25	9065/48	✓	✓	✓	✓													2KJ3508 - ■ ■ A 0 ■ - 0 ■ G2
171.69	8.4	820	13 900	6	0.31	45325/264	✓	✓	✓	✓													2KJ3508 - ■ ■ A 0 ■ - 0 ■ F2
153.18	9.5	820	13 900	6	0.35	132349/864	✓	✓	✓	✓	✓	✓											2KJ3508 - ■ ■ A 0 ■ - 0 ■ E2
137.35	11	820	13 900	6	0.42	9065/66	✓	✓	✓	✓	✓	✓											2KJ3508 - ■ ■ A 0 ■ - 0 ■ D2
123.80	12	820	13 900	6	0.50	106967/864	✓	✓	✓	✓	✓	✓											2KJ3508 - ■ ■ A 0 ■ - 0 ■ C2
114.28	13	820	13 900	6	0.59	106967/936	✓	✓	✓	✓	✓	✓											2KJ3508 - ■ ■ A 0 ■ - 0 ■ B2
104.32	14	820	13 900	6	0.70	7511/72	✓	✓	✓	✓	✓	✓	✓										2KJ3508 - ■ ■ A 0 ■ - 0 ■ A2
86.56	17	820	13 900	6	0.89	99715/1152	✓	✓	✓	✓	✓	✓	✓										2KJ3508 - ■ ■ A 0 ■ - 0 ■ X1
81.47	18	820	13 900	6	1.02	99715/1224	✓	✓	✓	✓	✓	✓	✓										2KJ3508 - ■ ■ A 0 ■ - 0 ■ W1
76.94	19	820	13 900	6	1.16	99715/1296	✓	✓	✓	✓	✓	✓	✓										2KJ3508 - ■ ■ A 0 ■ - 0 ■ V1
65.47	22	820	13 900	6	1.42	23569/360	✓	✓	✓	✓	✓	✓	✓										2KJ3508 - ■ ■ A 0 ■ - 0 ■ U1
56.08	26	820	13 900	6	1.73	88837/1584			✓	✓	✓	✓	✓										2KJ3508 - ■ ■ A 0 ■ - 0 ■ T1
49.31	29	820	13 900	6	2.10	85211/1728			✓	✓	✓	✓	✓										2KJ3508 - ■ ■ A 0 ■ - 0 ■ S1
41.60	35	800	14 000	6	2.70	34447/828			✓	✓	✓	✓	✓										2KJ3508 - ■ ■ A 0 ■ - 0 ■ R1
36.26	40	770	14 000	6	3.60	1813/50			✓	✓	✓	✓	✓										2KJ3508 - ■ ■ A 0 ■ - 0 ■ Q1
32.78	44	820	13 900	7	0.94	6293/192	✓	✓	✓	✓	✓	✓	✓										2KJ3508 - ■ ■ A 0 ■ - 0 ■ P1
27.20	53	800	14 000	7	1.23	83545/3072	✓	✓	✓	✓	✓	✓	✓										2KJ3508 - ■ ■ A 0 ■ - 0 ■ N1
25.60	57	785	14 000	7	1.41	83545/3264	✓	✓	✓	✓	✓	✓	✓										2KJ3508 - ■ ■ A 0 ■ - 0 ■ M1
24.17	60	770	14 000	7	1.60	83545/3456	✓	✓	✓	✓	✓	✓	✓										2KJ3508 - ■ ■ A 0 ■ - 0 ■ L1
20.57	70	740	14 100	7	2.00	19747/960	✓	✓	✓	✓	✓	✓	✓										2KJ3508 - ■ ■ A 0 ■ - 0 ■ K1
17.62	82	715	13 800	8	2.60	74431/4224			✓	✓	✓	✓	✓										2KJ3508 - ■ ■ A 0 ■ - 0 ■ J1
15.49	94	695	13 300	8	3.20	71393/4608			✓	✓	✓	✓	✓										2KJ3508 - ■ ■ A 0 ■ - 0 ■ H1
13.07	111	665	12 600	8	4.20	28861/2208			✓	✓	✓	✓	✓										2KJ3508 - ■ ■ A 0 ■ - 0 ■ G1
11.39	127	645	12 000	8	5.50	4557/400			✓	✓	✓	✓	✓										2KJ3508 - ■ ■ A 0 ■ - 0 ■ F1
10.51	138	445	12 600	10	2.30	1209/115	✓	✓	✓	✓	✓	✓	✓										2KJ3508 - ■ ■ A 0 ■ - 0 ■ E1
9.01	161	450	11 900	11	3.00	4557/506			✓	✓	✓	✓	✓										2KJ3508 - ■ ■ A 0 ■ - 0 ■ D1
7.92	183	450	11 300	11	3.70	1457/184			✓	✓	✓	✓	✓										2KJ3508 - ■ ■ A 0 ■ - 0 ■ C1
6.68	217	455	10 900	11	4.90	3534/529			✓	✓	✓	✓	✓										2KJ3508 - ■ ■ A 0 ■ - 0 ■ B1
5.82	249	430	10 700	12	6.60	3348/575			✓	✓	✓	✓	✓										2KJ3508 - ■ ■ A 0 ■ - 0 ■ A1

1) Only in conjunction with reduced-backlash version

Article No. supplement		1 or 9																					
Shaft design	→ Page 9/39																						
Adapter size		K4	B	C	D	E	F	G	H	J	K	L	M	N									4
		K2			D	E	F	G	H	J	K	L	M	N	P	Q							2
		KQ	A	B	C		D	E															7
		K8					A	B		C		D	E	F									8
		K5		A	B	C		D	E		F	G	H										5
		K3		A	B	C		D	E		F	G	H										3
Adapter type																							
Gearbox mounting type	→ Page 9/34		A, B, F or H																				

SIMOGEAR Gearboxes

Bevel gearboxes

Transmission ratios and torques

Selection and ordering data (continued)

Gearbox							Adapter													Article No.		
i	n_2	T_{2N}	F_{R2}	ϕ ¹⁾	J_G	R_{ex}	K4	63	71	80	90	100	112	132	160	180	200	225	250	280	315	(Article No. supplement → below)
-	rpm	Nm	N	'	10 ⁻⁴	-	K2			80	90	100	112	132	160	180	200	225	250			
							KQ	703	704	706		708	710									
							K8					808	810		813		816		818	822		
							K5	56		140	180		210	250		280	320	360				
							K3	56		140	180		210	250		280	320	360				
K.89																						
231.80	6.3	1 600	18 100	7	0.42	10199/44		✓	✓	✓												2KJ3510 - ■ A 0 ■ - 0 ■ K2
210.72	6.9	1 600	18 100	7	0.51	50995/242		✓	✓	✓												2KJ3510 - ■ A 0 ■ - 0 ■ J2
189.01	7.7	1 600	18 100	7	0.71	149695/792		✓	✓	✓	✓	✓										2KJ3510 - ■ A 0 ■ - 0 ■ H2
169.94	8.5	1 600	18 100	7	0.80	41125/242		✓	✓	✓	✓	✓										2KJ3510 - ■ A 0 ■ - 0 ■ G2
153.70	9.4	1 600	18 100	7	0.88	60865/396		✓	✓	✓	✓	✓										2KJ3510 - ■ A 0 ■ - 0 ■ F2
141.88	10	1 600	18 100	7	1.05	60865/429		✓	✓	✓	✓	✓										2KJ3510 - ■ A 0 ■ - 0 ■ E2
129.96	11	1 600	18 100	7	1.37	17155/132		✓	✓	✓	✓	✓	✓	✓								2KJ3510 - ■ A 0 ■ - 0 ■ D2
109.04	13	1 600	18 100	7	1.45	57575/528		✓	✓	✓	✓	✓	✓	✓	✓							2KJ3510 - ■ A 0 ■ - 0 ■ C2
102.63	14	1 600	18 100	7	1.66	57575/561		✓	✓	✓	✓	✓	✓	✓	✓							2KJ3510 - ■ A 0 ■ - 0 ■ B2
94.16	15	1 600	18 100	7	1.81	27965/297		✓	✓	✓	✓	✓	✓	✓	✓							2KJ3510 - ■ A 0 ■ - 0 ■ A2
82.25	18	1 600	18 100	7	2.60	329/4		✓	✓	✓	✓	✓	✓	✓	✓							2KJ3510 - ■ A 0 ■ - 0 ■ X1
73.64	20	1 600	18 100	7	3.20	106925/1452			✓	✓	✓	✓	✓	✓	✓							2KJ3510 - ■ A 0 ■ - 0 ■ W1
64.39	23	1 600	18 100	7	3.70	50995/792			✓	✓	✓	✓	✓	✓	✓							2KJ3510 - ■ A 0 ■ - 0 ■ V1
55.27	26	1 600	18 100	7	4.10	27965/506			✓	✓	✓	✓	✓	✓	✓							2KJ3510 - ■ A 0 ■ - 0 ■ U1
48.85	30	1 600	18 100	7	5.20	16121/330			✓	✓	✓	✓	✓	✓	✓							2KJ3510 - ■ A 0 ■ - 0 ■ T1
41.54	35	1 570	18 100	7	6.60	8225/198					✓	✓	✓	✓	✓							2KJ3510 - ■ A 0 ■ - 0 ■ S1
39.29	37	1 600	18 100	9	1.86	11315/288		✓	✓	✓	✓	✓	✓	✓	✓							2KJ3510 - ■ A 0 ■ - 0 ■ R1
32.96	44	1 600	18 100	8	2.10	37975/1152		✓	✓	✓	✓	✓	✓	✓	✓							2KJ3510 - ■ A 0 ■ - 0 ■ Q1
31.03	47	1 600	18 100	8	2.40	37975/1224		✓	✓	✓	✓	✓	✓	✓	✓							2KJ3510 - ■ A 0 ■ - 0 ■ P1
28.46	51	1 600	18 100	8	2.70	18445/648		✓	✓	✓	✓	✓	✓	✓	✓							2KJ3510 - ■ A 0 ■ - 0 ■ N1
24.86	58	1 600	18 100	9	3.80	2387/96		✓	✓	✓	✓	✓	✓	✓	✓							2KJ3510 - ■ A 0 ■ - 0 ■ M1
22.26	65	1 600	18 100	9	4.70	70525/3168			✓	✓	✓	✓	✓	✓	✓							2KJ3510 - ■ A 0 ■ - 0 ■ L1
19.46	75	1 560	17 900	9	5.70	33635/1728			✓	✓	✓	✓	✓	✓	✓							2KJ3510 - ■ A 0 ■ - 0 ■ K1
16.71	87	1 480	17 200	9	6.80	18445/1104			✓	✓	✓	✓	✓	✓	✓							2KJ3510 - ■ A 0 ■ - 0 ■ J1
14.77	98	1 420	16 600	9	8.60	10633/720			✓	✓	✓	✓	✓	✓	✓							2KJ3510 - ■ A 0 ■ - 0 ■ H1
12.56	115	1 330	16 300	9	11.00	5425/432					✓	✓	✓	✓	✓							2KJ3510 - ■ A 0 ■ - 0 ■ G1
10.76	135	1 250	16 100	9	15.00	775/72						✓	✓	✓	✓							2KJ3510 - ■ A 0 ■ - 0 ■ F1
10.51	138	845	16 100	13	6.40	6727/640			✓	✓	✓	✓	✓	✓	✓							2KJ3510 - ■ A 0 ■ - 0 ■ E1
9.02	161	800	15 400	14	7.70	33201/3680			✓	✓	✓	✓	✓	✓	✓							2KJ3510 - ■ A 0 ■ - 0 ■ D1
7.97	182	770	14 800	14	9.80	31899/4000			✓	✓	✓	✓	✓	✓	✓							2KJ3510 - ■ A 0 ■ - 0 ■ C1
6.78	214	720	14 500	14	13.00	217/32					✓	✓	✓	✓	✓							2KJ3510 - ■ A 0 ■ - 0 ■ B1
5.81	250	675	14 200	14	17.00	93/16						✓	✓	✓	✓							2KJ3510 - ■ A 0 ■ - 0 ■ A1

¹⁾ Only in conjunction with reduced-backlash version

Article No. supplement		1 or 9																					
Shaft design	→ Page 9/39																						4
Adapter size		K4	B	C	D	E	F	G	H	J	K	L	M	N									2
		K2			D	E	F	G	H	J	K	L	M	N	P	Q							7
		KQ	A	B	C		D	E														8	
		K8					A	B		C		D	E	F								5	
		K5	A		B	C		D	E		F	G	H									3	
		K3	A		B	C		D	E		F	G	H										
Adapter type																							
Gearbox mounting type	→ Page 9/34	A, B, F or H																					

Selection and ordering data (continued)

Gearbox							Adapter													Article No.		
i	n ₂	T _{2N}	F _{R2}	φ ¹⁾	J _G	R _{ex}	K4	63	71	80	90	100	112	132	160	180	200	225	250	280	315	(Article No. supplement → below)
-	rpm	Nm	N	'	10 ⁻⁴	-	K2			80	90	100	112	132	160	180	200	225	250			
							KQ	703	704	706		708	710									
							K8					808	810		813		816		818	822		
							K5	56		140	180		210	250		280	320	360				
							K3	56		140	180		210	250		280	320	360				
K.109																						
216.65	6.7	2 900	24 500	-	1.27	107242/495			✓	✓	✓	✓										2KJ3511 - ■ A 0 ■ - 0 ■ H2
195.60	7.4	2 900	24 500	-	1.37	118336/605			✓	✓	✓	✓										2KJ3511 - ■ A 0 ■ - 0 ■ G2
177.43	8.2	2 900	24 500	-	1.61	35131/198			✓	✓	✓	✓										2KJ3511 - ■ A 0 ■ - 0 ■ F2
163.78	8.9	2 900	24 500	-	1.9	70262/429			✓	✓	✓	✓										2KJ3511 - ■ A 0 ■ - 0 ■ E2
148.88	9.7	2 900	24 500	-	2.2	57319/385			✓	✓	✓	✓	✓	✓								2KJ3511 - ■ A 0 ■ - 0 ■ D2
126.07	12	2 900	24 500	-	2.6	5547/44			✓	✓	✓	✓	✓	✓								2KJ3511 - ■ A 0 ■ - 0 ■ C2
118.65	12	2 900	24 500	-	2.6	22188/187			✓	✓	✓	✓	✓	✓								2KJ3511 - ■ A 0 ■ - 0 ■ B2
109.57	13	2 900	24 500	-	4.1	14792/135			✓	✓	✓	✓	✓	✓								2KJ3511 - ■ A 0 ■ - 0 ■ A2
97.49	15	2 900	24 500	-	5.0	53621/550			✓	✓	✓	✓	✓	✓								2KJ3511 - ■ A 0 ■ - 0 ■ X1
86.59	17	2 900	24 500	-	6.0	31433/363			✓	✓	✓	✓	✓	✓								2KJ3511 - ■ A 0 ■ - 0 ■ W1
77.51	19	2 900	24 500	-	5.9	153467/1980			✓	✓	✓	✓	✓	✓								2KJ3511 - ■ A 0 ■ - 0 ■ V1
66.26	22	2 900	24 500	-	6.8	251464/3795			✓	✓	✓	✓	✓	✓								2KJ3511 - ■ A 0 ■ - 0 ■ U1
59.17	25	2 900	24 500	-	8.6	7396/125			✓	✓	✓	✓	✓	✓	✓							2KJ3511 - ■ A 0 ■ - 0 ■ T1
52.29	28	2 900	24 500	-	9.7	25886/495					✓	✓	✓	✓	✓							2KJ3511 - ■ A 0 ■ - 0 ■ S1
45.89	32	2 900	24 500	-	14	159014/3465					✓	✓	✓	✓	✓							2KJ3511 - ■ A 0 ■ - 0 ■ R1
39.95	36	2 820	23 900	-	17	151618/3795					✓	✓	✓	✓	✓							2KJ3511 - ■ A 0 ■ - 0 ■ Q1
34.15	42	2 710	22 700	-	21	118336/3465					✓	✓	✓	✓	✓							2KJ3511 - ■ A 0 ■ - 0 ■ P1
29.23	50	2 620	21 600	-	27	7396/253					✓	✓	✓	✓	✓							2KJ3511 - ■ A 0 ■ - 0 ■ N1
24.98	58	2 380	21 000	-	9.9	163744/6555			✓	✓	✓	✓	✓	✓								2KJ3511 - ■ A 0 ■ - 0 ■ M1
22.31	65	2 380	20 000	-	13	52976/2375			✓	✓	✓	✓	✓	✓	✓							2KJ3511 - ■ A 0 ■ - 0 ■ L1
19.71	74	2 380	18 900	-	15	16856/855					✓	✓	✓	✓	✓							2KJ3511 - ■ A 0 ■ - 0 ■ K1
17.30	84	2 400	17 800	-	20	14792/855					✓	✓	✓	✓	✓							2KJ3511 - ■ A 0 ■ - 0 ■ J1
15.06	96	2 310	17 500	-	25	98728/6555					✓	✓	✓	✓	✓							2KJ3511 - ■ A 0 ■ - 0 ■ H1
12.87	113	2 200	17 500	-	33	11008/855					✓	✓	✓	✓	✓							2KJ3511 - ■ A 0 ■ - 0 ■ G1
11.02	132	2 100	17 400	-	43	4816/437					✓	✓	✓	✓	✓							2KJ3511 - ■ A 0 ■ - 0 ■ F1
10.45	139	1 260	17 700	-	17	784/75					✓	✓	✓	✓	✓							2KJ3511 - ■ A 0 ■ - 0 ■ E1
9.17	158	1 270	16 700	-	23	688/75					✓	✓	✓	✓	✓							2KJ3511 - ■ A 0 ■ - 0 ■ D1
7.99	181	1 280	16 300	-	29	4592/575					✓	✓	✓	✓	✓							2KJ3511 - ■ A 0 ■ - 0 ■ C1
6.83	212	1 300	16 100	-	38	512/75					✓	✓	✓	✓	✓							2KJ3511 - ■ A 0 ■ - 0 ■ B1
5.84	248	1 300	15 700	-	49	672/115					✓	✓	✓	✓	✓							2KJ3511 - ■ A 0 ■ - 0 ■ A1

¹⁾ Only in conjunction with reduced-backlash version

Article No. supplement		1 or 9																					
Shaft design	→ Page 9/39																						4
Adapter size		K4	B	C	D	E	F	G	H	J	K	L	M	N									2
		K2			D	E	F	G	H	J	K	L	M	N	P	Q							7
		KQ	A	B	C			D	E														8
		K8						A	B		C		D		E	F							5
		K5	A		B	C			D	E		F	G	H									3
		K3	A		B	C			D	E		F	G	H									
Adapter type																							
Gearbox mounting type	→ Page 9/34	A, B, F or H																					

SIMOGEAR Gearboxes

Bevel gearboxes

Transmission ratios and torques

Selection and ordering data (continued)

Gearbox							Adapter													Article No.						
i	n ₂	T _{2N}	F _{R2}	φ ¹⁾	J _G	R _{ex}	K4	63	71	80	90	100	112	132	160	180	200	225	250					(Article No. supplement → below)		
-	rpm	Nm	N	'	10 ⁻⁴	-	K2			80	90	100	112	132	160	180	200	225	250	280	315					
							KQ	703	704	706		708	710													
							K8					808	810		813		816			818	822					
							K5	56		140	180		210	250		280	320	360								
							K3	56		140	180		210	250		280	320	360								
K.129																										
228.30	6.4	4 400	37 600	-	3.3	30821/135				✓	✓	✓												2KJ3512 - ■ A 0 ■ - 0 ■ J2		
210.74	6.9	4 400	37 600	-	3.9	123284/585				✓	✓	✓												2KJ3512 - ■ A 0 ■ - 0 ■ H2		
194.04	7.5	4 400	37 600	-	4.5	8732/45				✓	✓	✓	✓	✓										2KJ3512 - ■ A 0 ■ - 0 ■ G2		
165.47	8.8	4 400	37 600	-	5.6	5957/36				✓	✓	✓	✓	✓										2KJ3512 - ■ A 0 ■ - 0 ■ F2		
155.74	9.3	4 400	37 600	-	6.4	23828/153				✓	✓	✓	✓	✓										2KJ3512 - ■ A 0 ■ - 0 ■ E2		
144.53	10	4 400	37 600	-	7.0	58534/405				✓	✓	✓	✓	✓										2KJ3512 - ■ A 0 ■ - 0 ■ D2		
127.77	11	4 400	37 600	-	8.4	9583/75				✓	✓	✓	✓	✓										2KJ3512 - ■ A 0 ■ - 0 ■ C2		
114.06	13	4 400	37 600	-	10	56462/495				✓	✓	✓	✓	✓										2KJ3512 - ■ A 0 ■ - 0 ■ B2		
102.64	14	4 400	37 600	-	12	27713/270				✓	✓	✓	✓	✓										2KJ3512 - ■ A 0 ■ - 0 ■ A2		
89.09	16	4 400	37 600	-	14	92204/1035				✓	✓	✓	✓	✓										2KJ3512 - ■ A 0 ■ - 0 ■ X1		
80.12	18	4 400	37 600	-	17	30044/375				✓	✓	✓	✓	✓	✓									2KJ3512 - ■ A 0 ■ - 0 ■ W1		
70.03	21	4 400	37 600	-	19	18907/270					✓	✓	✓	✓	✓	✓								2KJ3512 - ■ A 0 ■ - 0 ■ V1		
62.49	23	4 400	36 200	-	23	2812/45					✓	✓	✓	✓	✓	✓	✓							2KJ3512 - ■ A 0 ■ - 0 ■ U1		
55.05	26	4 400	34 300	-	27	11396/207					✓	✓	✓	✓	✓	✓	✓							2KJ3512 - ■ A 0 ■ - 0 ■ T1		
48.24	30	4 400	32 400	-	33	6512/135					✓	✓	✓	✓	✓	✓	✓							2KJ3512 - ■ A 0 ■ - 0 ■ S1		
42.04	34	4 400	30 500	-	39	14504/345					✓	✓	✓	✓	✓	✓	✓							2KJ3512 - ■ A 0 ■ - 0 ■ R1		
38.37	38	4 400	29 200	-	45	1036/27					✓	✓	✓	✓	✓	✓	✓							2KJ3512 - ■ A 0 ■ - 0 ■ Q1		
33.03	44	4 400	27 300	-	55	11396/345							✓	✓	✓	✓	✓							2KJ3512 - ■ A 0 ■ - 0 ■ P1		
31.55	46	4 400	26 700	-	23	3944/125				✓	✓	✓	✓	✓	✓									2KJ3512 - ■ A 0 ■ - 0 ■ N1		
27.58	53	4 400	25 100	-	27	1241/45					✓	✓	✓	✓	✓	✓								2KJ3512 - ■ A 0 ■ - 0 ■ M1		
24.61	59	4 400	23 700	-	33	2584/105					✓	✓	✓	✓	✓	✓	✓							2KJ3512 - ■ A 0 ■ - 0 ■ L1		
21.68	67	4 270	22 700	-	40	1496/69					✓	✓	✓	✓	✓	✓	✓							2KJ3512 - ■ A 0 ■ - 0 ■ K1		
19.00	76	4 140	21 700	-	50	5984/315					✓	✓	✓	✓	✓	✓	✓							2KJ3512 - ■ A 0 ■ - 0 ■ J1		
16.56	88	4 020	20 700	-	62	1904/115					✓	✓	✓	✓	✓	✓	✓							2KJ3512 - ■ A 0 ■ - 0 ■ H1		
15.11	96	3 940	20 000	-	72	136/9					✓	✓	✓	✓	✓	✓	✓							2KJ3512 - ■ A 0 ■ - 0 ■ G1		
13.01	111	3 810	19 000	-	91	1496/115							✓	✓	✓	✓	✓							2KJ3512 - ■ A 0 ■ - 0 ■ F1		
11.80	123	2 830	21 400	-	46	119680/10143					✓	✓	✓	✓	✓	✓	✓							2KJ3512 - ■ A 0 ■ - 0 ■ E1		
10.34	140	2 850	20 100	-	57	95744/9261					✓	✓	✓	✓	✓	✓	✓							2KJ3512 - ■ A 0 ■ - 0 ■ D1		
9.01	161	2 760	19 500	-	71	4352/483					✓	✓	✓	✓	✓	✓	✓							2KJ3512 - ■ A 0 ■ - 0 ■ C1		
8.22	176	2 680	19 500	-	83	10880/1323					✓	✓	✓	✓	✓	✓	✓							2KJ3512 - ■ A 0 ■ - 0 ■ B1		
7.08	205	2 530	19 500	-	107	23936/3381					✓	✓	✓	✓	✓	✓	✓							2KJ3512 - ■ A 0 ■ - 0 ■ A1		

¹⁾ Only in conjunction with reduced-backlash version

Article No. supplement																									
Shaft design	→ Page 9/39	1 or 9																							
Adapter size	K4	B	C	D	E	F	G	H	J	K	L	M	N												4
	K2			D	E	F	G	H	J	K	L	M	N	P	Q										2
	KQ		A	B	C		D	E																	7
	K8						A	B		C		D	E	F											8
	K5		A		B	C			D	E		F	G	H											5
K3		A		B	C			D	E		F	G	H											3	
Adapter type																									
Gearbox mounting type	→ Page 9/34	A, B, F or H																							

Selection and ordering data (continued)

Gearbox							Adapter										Article No. (Article No. supplement → below)								
	i	n ₂ rpm	T _{2N} Nm	F _{R2} N	φ ¹⁾	J _G 10 ⁻⁴ kgm ²	R _{ex}	K4	63	71	80	90	100	112	132	160		180	200	225	250	280	315		
K.149																									
237.03	6.1	8 000	65 000	-	7.1	83433/352					✓	✓	✓	✓	✓										2KJ3513 - ■ ■ A 0 ■ - 0 ■ J2
202.86	7.1	8 000	65 000	-	9.0	285621/1408					✓	✓	✓	✓	✓										2KJ3513 - ■ ■ A 0 ■ - 0 ■ H2
190.92	7.6	8 000	65 000	-	10	285621/1496					✓	✓	✓	✓	✓										2KJ3513 - ■ ■ A 0 ■ - 0 ■ G2
178.97	8.1	8 000	65 000	-	11	188993/1056					✓	✓	✓	✓	✓										2KJ3513 - ■ ■ A 0 ■ - 0 ■ F2
158.65	9.1	8 000	65 000	-	14	558453/3520					✓	✓	✓	✓	✓										2KJ3513 - ■ ■ A 0 ■ - 0 ■ E2
140.93	10	8 000	64 100	-	16	17052/121					✓	✓	✓	✓	✓										2KJ3513 - ■ ■ A 0 ■ - 0 ■ D2
127.16	11	8 000	61 500	-	19	89523/704					✓	✓	✓	✓	✓										2KJ3513 - ■ ■ A 0 ■ - 0 ■ C2
112.68	13	8 000	58 500	-	23	456141/4048					✓	✓	✓	✓	✓										2KJ3513 - ■ ■ A 0 ■ - 0 ■ B2
99.79	15	8 000	55 600	-	26	439089/4400					✓	✓	✓	✓	✓	✓									2KJ3513 - ■ ■ A 0 ■ - 0 ■ A2
88.81	16	8 000	52 900	-	31	1421/16						✓	✓	✓	✓	✓	✓								2KJ3513 - ■ ■ A 0 ■ - 0 ■ X1
79.59	18	8 000	50 500	-	37	14007/176						✓	✓	✓	✓	✓	✓	✓							2KJ3513 - ■ ■ A 0 ■ - 0 ■ W1
70.56	21	8 000	47 900	-	43	285621/4048						✓	✓	✓	✓	✓	✓	✓							2KJ3513 - ■ ■ A 0 ■ - 0 ■ V1
62.28	23	8 000	45 300	-	52	5481/88						✓	✓	✓	✓	✓	✓	✓	✓						2KJ3513 - ■ ■ A 0 ■ - 0 ■ U1
54.76	26	8 000	42 700	-	63	55419/1012						✓	✓	✓	✓	✓	✓	✓	✓						2KJ3513 - ■ ■ A 0 ■ - 0 ■ T1
49.60	29	8 000	40 800	-	70	8729/176						✓	✓	✓	✓	✓	✓	✓	✓						2KJ3513 - ■ ■ A 0 ■ - 0 ■ S1
43.18	34	8 000	38 300	-	85	174783/4048								✓	✓	✓	✓	✓	✓						2KJ3513 - ■ ■ A 0 ■ - 0 ■ R1
35.40	41	7 850	35 200	-	110	80997/2288								✓	✓	✓	✓	✓	✓						2KJ3513 - ■ ■ A 0 ■ - 0 ■ Q1
32.33	45	7 760	33 900	-	49	12673/392						✓	✓	✓	✓	✓	✓	✓	✓						2KJ3513 - ■ ■ A 0 ■ - 0 ■ P1
28.66	51	7 630	32 300	-	59	36917/1288						✓	✓	✓	✓	✓	✓	✓	✓						2KJ3513 - ■ ■ A 0 ■ - 0 ■ N1
25.30	57	7 420	30 900	-	73	4959/196						✓	✓	✓	✓	✓	✓	✓	✓	✓					2KJ3513 - ■ ■ A 0 ■ - 0 ■ M1
22.25	65	7 210	29 500	-	89	7163/322						✓	✓	✓	✓	✓	✓	✓	✓	✓					2KJ3513 - ■ ■ A 0 ■ - 0 ■ L1
20.15	72	7 070	28 500	-	103	23693/1176						✓	✓	✓	✓	✓	✓	✓	✓	✓					2KJ3513 - ■ ■ A 0 ■ - 0 ■ K1
17.54	83	6 890	28 500	-	128	22591/1288								✓	✓	✓	✓	✓	✓						2KJ3513 - ■ ■ A 0 ■ - 0 ■ J1
14.38	101	6 660	29 000	-	174	10469/728								✓	✓	✓	✓	✓	✓						2KJ3513 - ■ ■ A 0 ■ - 0 ■ H1
14.15	102	4 140	31 200	-	79	17328/1225						✓	✓	✓	✓	✓	✓	✓	✓						2KJ3513 - ■ ■ A 0 ■ - 0 ■ G1
12.44	117	4 030	29 800	-	97	150176/12075						✓	✓	✓	✓	✓	✓	✓	✓						2KJ3513 - ■ ■ A 0 ■ - 0 ■ F1
11.26	129	3 950	28 900	-	113	124184/11025						✓	✓	✓	✓	✓	✓	✓	✓						2KJ3513 - ■ ■ A 0 ■ - 0 ■ E1
9.81	148	3 850	28 400	-	141	118408/12075								✓	✓	✓	✓	✓	✓						2KJ3513 - ■ ■ A 0 ■ - 0 ■ D1
8.04	180	3 720	28 000	-	194	54872/6825								✓	✓	✓	✓	✓	✓						2KJ3513 - ■ ■ A 0 ■ - 0 ■ C1
6.82	213	3 630	27 600	-	266	89528/13125								✓	✓	✓	✓	✓	✓						2KJ3512 - ■ ■ A 0 ■ - 0 ■ B1

¹⁾ Only in conjunction with reduced-backlash version

Article No. supplement																		
Shaft design	→ Page 9/39	1 or 9																
Adapter size		K4	B	C	D	E	F	G	H	J	K	L	M	N			4	
		K2			D	E	F	G	H	J	K	L	M	N	P	Q		2
		KQ		A	B	C		D	E									7
		K8						A	B		C		D		E	F		8
		K5		A		B	C		D	E		F	G	H				5
Adapter type		K3	A		B	C		D	E		F	G	H				3	
Gearbox mounting type	→ Page 9/34	A, B, F or H																

SIMOGEAR Gearboxes

Bevel gearboxes

Transmission ratios and torques

Selection and ordering data (continued)

Gearbox							Adapter													Article No.						
i	n_2	T_{2N}	F_{R2}	ϕ ¹⁾	J_G	R_{ex}	K4	63	71	80	90	100	112	132	160	180	200	225	250					(Article No. supplement → below)		
-	rpm	Nm	N	'	10^{-4}	-	K2			80	90	100	112	132	160	180	200	225	250	280	315					
							KQ	703	704	706		708	710													
							K8					808	810		813		816			818	822					
							K5	56		140	180		210	250		280	320	360								
							K3	56		140	180		210	250		280	320	360								
K.169																										
223.30	6.5	13 000	70 000	-	18	273319/1224					✓	✓	✓	✓										2KJ3514 - ■ ■ A 0 ■ - 0 ■ F2		
208.35	7	13 000	70 000	-	20	135013/648					✓	✓	✓	✓										2KJ3514 - ■ ■ A 0 ■ - 0 ■ E2		
185.23	7.8	13 000	70 000	-	24	29637/160					✓	✓	✓	✓										2KJ3514 - ■ ■ A 0 ■ - 0 ■ D2		
166.31	8.7	13 000	70 000	-	28	16465/99					✓	✓	✓	✓										2KJ3514 - ■ ■ A 0 ■ - 0 ■ C2		
150.55	9.6	13 000	70 000	-	33	260147/1728					✓	✓	✓	✓										2KJ3514 - ■ ■ A 0 ■ - 0 ■ B2		
132.24	11	13 000	70 000	-	40	437969/3312					✓	✓	✓	✓										2KJ3514 - ■ ■ A 0 ■ - 0 ■ A2		
119.83	12	13 000	70 000	-	47	431383/3600					✓	✓	✓	✓	✓									2KJ3514 - ■ ■ A 0 ■ - 0 ■ X1		
106.72	14	13 000	70 000	-	54	23051/216					✓	✓	✓	✓	✓	✓								2KJ3514 - ■ ■ A 0 ■ - 0 ■ W1		
95.83	15	13 000	70 000	-	65	36223/378					✓	✓	✓	✓	✓	✓	✓							2KJ3514 - ■ ■ A 0 ■ - 0 ■ V1		
85.51	17	13 000	70 000	-	75	141599/1656					✓	✓	✓	✓	✓	✓	✓							2KJ3514 - ■ ■ A 0 ■ - 0 ■ U1		
76.23	19	13 000	70 000	-	87	16465/216					✓	✓	✓	✓	✓	✓	✓	✓	✓	✓	✓	✓	✓	2KJ3514 - ■ ■ A 0 ■ - 0 ■ T1		
67.61	21	13 000	67 000	-	103	55981/828					✓	✓	✓	✓	✓	✓	✓	✓	✓	✓	✓	✓	✓	2KJ3514 - ■ ■ A 0 ■ - 0 ■ S1		
62.07	23	13 000	64 500	-	114	62567/1008					✓	✓	✓	✓	✓	✓	✓	✓	✓	✓	✓	✓	✓	2KJ3514 - ■ ■ A 0 ■ - 0 ■ R1		
54.68	27	13 000	61 000	-	134	181115/3312							✓	✓	✓	✓	✓	✓	✓	✓	✓	✓	✓	2KJ3514 - ■ ■ A 0 ■ - 0 ■ Q1		
44.86	32	13 000	55 700	-	180	55981/1248							✓	✓	✓	✓	✓	✓	✓	✓	✓	✓	✓	2KJ3514 - ■ ■ A 0 ■ - 0 ■ P1		
39.33	37	13 000	52 400	-	198	141599/3600							✓	✓	✓	✓	✓	✓	✓	✓	✓	✓	✓	2KJ3514 - ■ ■ A 0 ■ - 0 ■ N1		
30.75	47	13 000	46 500	-	309	42809/1392							✓	✓	✓	✓	✓	✓	✓	✓	✓	✓	✓	2KJ3514 - ■ ■ A 0 ■ - 0 ■ M1		
29.43	49	13 000	45 500	-	133	25721/874					✓	✓	✓	✓	✓	✓	✓	✓	✓	✓	✓	✓	✓	2KJ3514 - ■ ■ A 0 ■ - 0 ■ L1		
27.02	54	13 000	43 600	-	151	1513/56					✓	✓	✓	✓	✓	✓	✓	✓	✓	✓	✓	✓	✓	2KJ3514 - ■ ■ A 0 ■ - 0 ■ K1		
23.80	61	13 000	40 800	-	181	83215/3496							✓	✓	✓	✓	✓	✓	✓	✓	✓	✓	✓	2KJ3514 - ■ ■ A 0 ■ - 0 ■ J1		
19.53	74	12 700	40 000	-	249	77163/3952							✓	✓	✓	✓	✓	✓	✓	✓	✓	✓	✓	2KJ3514 - ■ ■ A 0 ■ - 0 ■ H1		
17.12	85	12 400	40 800	-	288	65059/3800							✓	✓	✓	✓	✓	✓	✓	✓	✓	✓	✓	2KJ3514 - ■ ■ A 0 ■ - 0 ■ G1		
13.39	108	11 900	41 300	-	457	59007/4408							✓	✓	✓	✓	✓	✓	✓	✓	✓	✓	✓	2KJ3514 - ■ ■ A 0 ■ - 0 ■ F1		
12.20	119	6 760	38 800	-	202	143990/11799							✓	✓	✓	✓	✓	✓	✓	✓	✓	✓	✓	2KJ3514 - ■ ■ A 0 ■ - 0 ■ E1		
10.01	145	6 530	37 800	-	280	22253/2223							✓	✓	✓	✓	✓	✓	✓	✓	✓	✓	✓	2KJ3514 - ■ ■ A 0 ■ - 0 ■ D1		
8.78	165	6 360	37 800	-	328	112574/12825							✓	✓	✓	✓	✓	✓	✓	✓	✓	✓	✓	2KJ3514 - ■ ■ A 0 ■ - 0 ■ C1		
6.86	211	6 130	37 300	-	523	34034/4959							✓	✓	✓	✓	✓	✓	✓	✓	✓	✓	✓	2KJ3512 - ■ ■ A 0 ■ - 0 ■ B1		

1) Only in conjunction with reduced-backlash version

Article No. supplement		1 or 9																						
Shaft design	→ Page 9/39																							
Adapter size		K4	B	C	D	E	F	G	H	J	K	L	M	N										4
		K2			D	E	F	G	H	J	K	L	M	N	P	Q								2
		KQ	A	B	C			D	E															7
		K8						A	B		C		D		E	F								8
		K5	A		B	C			D	E		F	G	H										5
		K3	A		B	C			D	E		F	G	H										3
Adapter type																								
Gearbox mounting type	→ Page 9/34	A, B, F or H																						

Selection and ordering data (continued)

Gearbox							Adapter											Article No.					
i	n_2	T_{2N}	F_{R2}	ϕ ¹⁾	J_G	R_{ex}	K4	63	71	80	90	100	112	132	160	180	200	225	250			(Article No. supplement → below)	
-	rpm	Nm	N	'	10^{-4}	-	K2			80	90	100	112	132	160	180	200	225	250	280	315		
							KQ	703	704	706		708	710										
							K8					808	810		813		816		818	822			
							K5	56		140	180		210	250		280	320	360					
							K3	56		140	180		210	250		280	320	360					
K.189																							
199.51	7.3	19 100	104 000	-	37	186543/935							✓	✓	✓								2KJ3515 - ■ ■ A 0 ■ - 0 ■ W1
178.49	8.1	19 500	104 000	-	43	367164/2057							✓	✓	✓								2KJ3515 - ■ ■ A 0 ■ - 0 ■ V1
160.98	9	19 500	104 000	-	50	60207/374							✓	✓	✓								2KJ3515 - ■ ■ A 0 ■ - 0 ■ U1
142.28	10	19 500	104 000	-	62	611940/4301							✓	✓	✓								2KJ3515 - ■ ■ A 0 ■ - 0 ■ T1
130.05	11	19 500	104 000	-	73	55272/425							✓	✓	✓	✓							2KJ3515 - ■ ■ A 0 ■ - 0 ■ S1
117.00	12	19 500	104 000	-	86	43757/374							✓	✓	✓	✓	✓						2KJ3515 - ■ ■ A 0 ■ - 0 ■ R1
104.56	14	19 500	104 000	-	100	19552/187							✓	✓	✓	✓	✓	✓					2KJ3515 - ■ ■ A 0 ■ - 0 ■ Q1
94.55	15	19 500	104 000	-	119	406644/4301							✓	✓	✓	✓	✓	✓					2KJ3515 - ■ ■ A 0 ■ - 0 ■ P1
83.44	17	19 500	104 000	-	140	15604/187							✓	✓	✓	✓	✓	✓	✓	✓			2KJ3515 - ■ ■ A 0 ■ - 0 ■ N1
74.35	20	19 500	104 000	-	164	319788/4301							✓	✓	✓	✓	✓	✓	✓	✓			2KJ3515 - ■ ■ A 0 ■ - 0 ■ M1
67.36	22	19 500	104 000	-	182	12596/187							✓	✓	✓	✓	✓	✓	✓	✓	✓		2KJ3515 - ■ ■ A 0 ■ - 0 ■ L1
60.58	24	19 500	104 000	-	220	23688/391							✓	✓	✓	✓	✓	✓	✓	✓	✓		2KJ3515 - ■ ■ A 0 ■ - 0 ■ K1
50.34	29	19 500	104 000	-	273	122388/2431							✓	✓	✓	✓	✓	✓	✓	✓	✓		2KJ3515 - ■ ■ A 0 ■ - 0 ■ J1
44.76	32	19 500	99 200	-	334	209244/4675							✓	✓	✓	✓	✓	✓	✓	✓	✓		2KJ3515 - ■ ■ A 0 ■ - 0 ■ H1
35.67	41	19 500	90 000	-	455	193452/5423							✓	✓	✓	✓	✓	✓	✓	✓	✓		2KJ3515 - ■ ■ A 0 ■ - 0 ■ G1
28.39	51	19 500	81 400	-	586	153972/5423									✓	✓	✓	✓	✓	✓	✓		2KJ3515 - ■ ■ A 0 ■ - 0 ■ F1
25.37	57	19 500	77 300	-	335	11088/437							✓	✓	✓	✓	✓	✓	✓	✓	✓		2KJ3515 - ■ ■ A 0 ■ - 0 ■ E1
21.09	69	19 500	71 000	-	439	5208/247							✓	✓	✓	✓	✓	✓	✓	✓	✓		2KJ3515 - ■ ■ A 0 ■ - 0 ■ D1
18.75	77	19 500	67 100	-	545	8904/475							✓	✓	✓	✓	✓	✓	✓	✓	✓		2KJ3515 - ■ ■ A 0 ■ - 0 ■ C1
14.94	97	19 500	60 000	-	786	8232/551							✓	✓	✓	✓	✓	✓	✓	✓	✓		2KJ3515 - ■ ■ A 0 ■ - 0 ■ B1
11.89	122	19 500	61 300	-	1 109	6552/551									✓	✓	✓	✓	✓	✓	✓		2KJ3512 - ■ ■ A 0 ■ - 0 ■ A1

1) Only in conjunction with reduced-backlash version

Article No. supplement		1 or 9																					
Shaft design	→ Page 9/39																						
Adapter size		K4	B	C	D	E	F	G	H	J	K	L	M	N									4
		K2			D	E	F	G	H	J	K	L	M	N	P	Q							2
		KQ	A	B	C			D	E														7
		K8						A	B		C		D	E	F								8
		K5	A		B	C			D	E		F	G	H									5
		K3	A		B	C			D	E		F	G	H									3
Adapter type																							
Gearbox mounting type	→ Page 9/34		A, B, F or H																				

SIMOGEAR Gearboxes

Bevel gearboxes

Dimensions

Dimensional drawing overview

Information about dimensional drawings can be found in Chapter [Introduction on page 1/20](#).

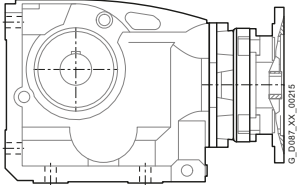
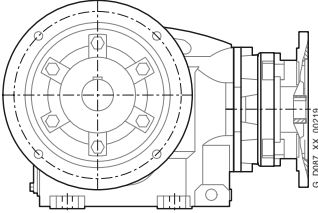
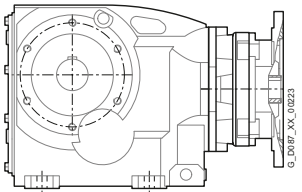
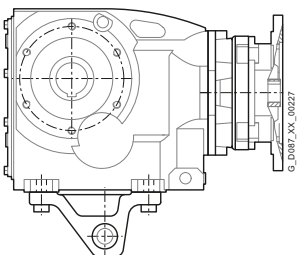
Representation	Gearbox type	Dimensional drawing on page
Bevel gearbox with adapter K4		
<i>Foot-mounted design</i>		
	B..29	5/19
	B..39	5/23
	B..49	5/27
	K..39	5/31
	K..49	5/35
	K..69	5/39
	K..79	5/43
	K..89	5/47
	K..109	5/51
	K..129	5/55
	K..149	5/59
	K..169	5/63
	K..189	5/67
	<i>Flange-mounted design</i>	
	B.F.29	5/20
	B.F.39	5/24
	B.F.49	5/28
	K.F.39	5/32
	K.F.49	5/36
	K.F.69	5/40
	K.F.79	5/44
	K.F.89	5/48
	K.F.109	5/52
	K.F.129	5/56
	K.F.149	5/60
	K.F.169	5/64
	K.F.189	5/68
	<i>Housing flange design</i>	
	B.Z.29	5/21
	B.Z.39	5/25
	B.Z.49	5/29
	K.Z.39	5/33
	K.Z.49	5/37
	K.Z.69	5/41
	K.Z.79	5/45
	K.Z.89	5/49
	K.Z.109	5/53
	K.Z.129	5/57
	K.Z.149	5/61
	K.Z.169	5/65
	K.Z.189	5/69
	<i>Shaft-mounted design</i>	
	BAD.29	5/22
	BAD.39	5/26
	BAD.49	5/30
	KAD.39	5/34
	KAD.49	5/38
	KAD.69	5/42
	KAD.79	5/46
	KAD.89	5/50
	KAD.109	5/54
	KAD.129	5/58
	KAD.149	5/62
	KAD.169	5/66
	KAD.189	5/70

Bevel gearbox with adapter K2

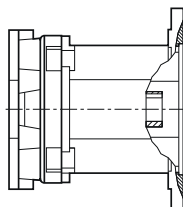

B..29 ... B..49	5/71
K..39 ... K..189	

Dimensional drawing overview (continued)

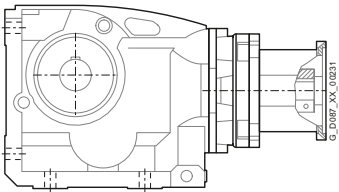
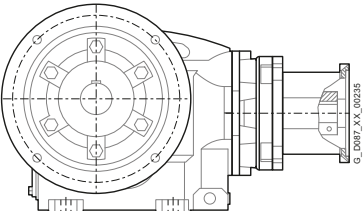
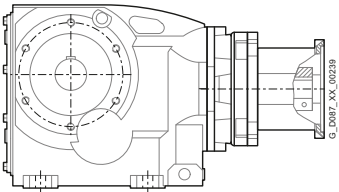
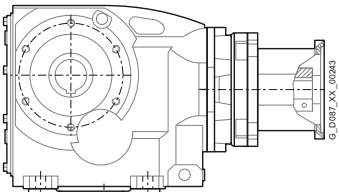
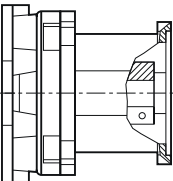

Representation	Gearbox type	Dimensional drawing on page
Bevel gearbox with adapter KQ		
<i>Foot-mounted design</i>		
	B..29	5/74
	B..39	5/78
	B..49	5/82
	K..39	5/86
	K..49	5/90
	K..69	5/94
	K..79	5/98
	K..89	5/102
	K..109	5/106
	K..129	5/110
	K..149	5/114
	K..169	5/118
	K..189	5/122
	<i>Flange-mounted design</i>	
	B.F.29	5/75
	B.F.39	5/79
	B.F.49	5/83
	K.F.39	5/87
	K.F.49	5/91
	K.F.69	5/95
	K.F.79	5/99
	K.F.89	5/103
	K.F.109	5/107
	K.F.129	5/111
	K.F.149	5/115
	K.F.169	5/119
	K.F.189	5/123
	<i>Housing flange design</i>	
	B.Z.29	5/76
	B.Z.39	5/80
	B.Z.49	5/84
	K.Z.39	5/88
	K.Z.49	5/92
	K.Z.69	5/96
	K.Z.79	5/100
	K.Z.89	5/104
	K.Z.109	5/108
	K.Z.129	5/112
	K.Z.149	5/116
	K.Z.169	5/120
	K.Z.189	5/124
	<i>Shaft-mounted design</i>	
	BAD.29	5/77
	BAD.39	5/81
	BAD.49	5/85
	KAD.39	5/89
	KAD.49	5/93
	KAD.69	5/97
	KAD.79	5/101
	KAD.89	5/105
	KAD.109	5/109
	KAD.129	5/113
	KAD.149	5/117
	KAD.169	5/121
	KAD.189	5/125
	Bevel gearbox with adapter KQS	
	B..29 ... B..49	5/126
	K..39 ... K..189	

SIMOGEAR Gearboxes

Bevel gearboxes

Dimensions

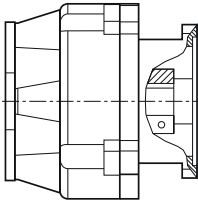
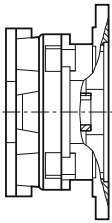
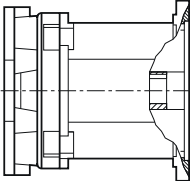
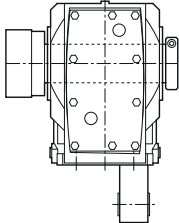
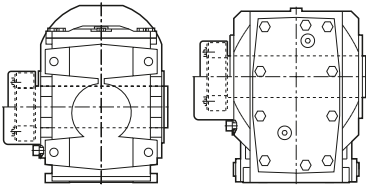
Dimensional drawing overview (continued)

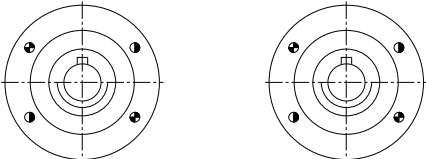
Representation	Gearbox type	Dimensional drawing on page
Bevel gearbox with adapter K8 	B..39 ... B..49 K..39 ... K..89	5/128
Bevel gearbox with adapter K5 	B..29 ... B..49 K..39 ... K..89	5/130
Bevel gearbox with adapter K3 	B..29 ... B..49 K..39 ... K..89	5/132
Additional versions and options 	SIMOLOC assembly system	5/134
	Protection cover for hollow shaft	5/136
	Inner contour of the flange design	5/137
	Pin holes	5/139

5

B..29 gearbox in a foot-mounted design

B030K4, BA030K4, BAS030K4

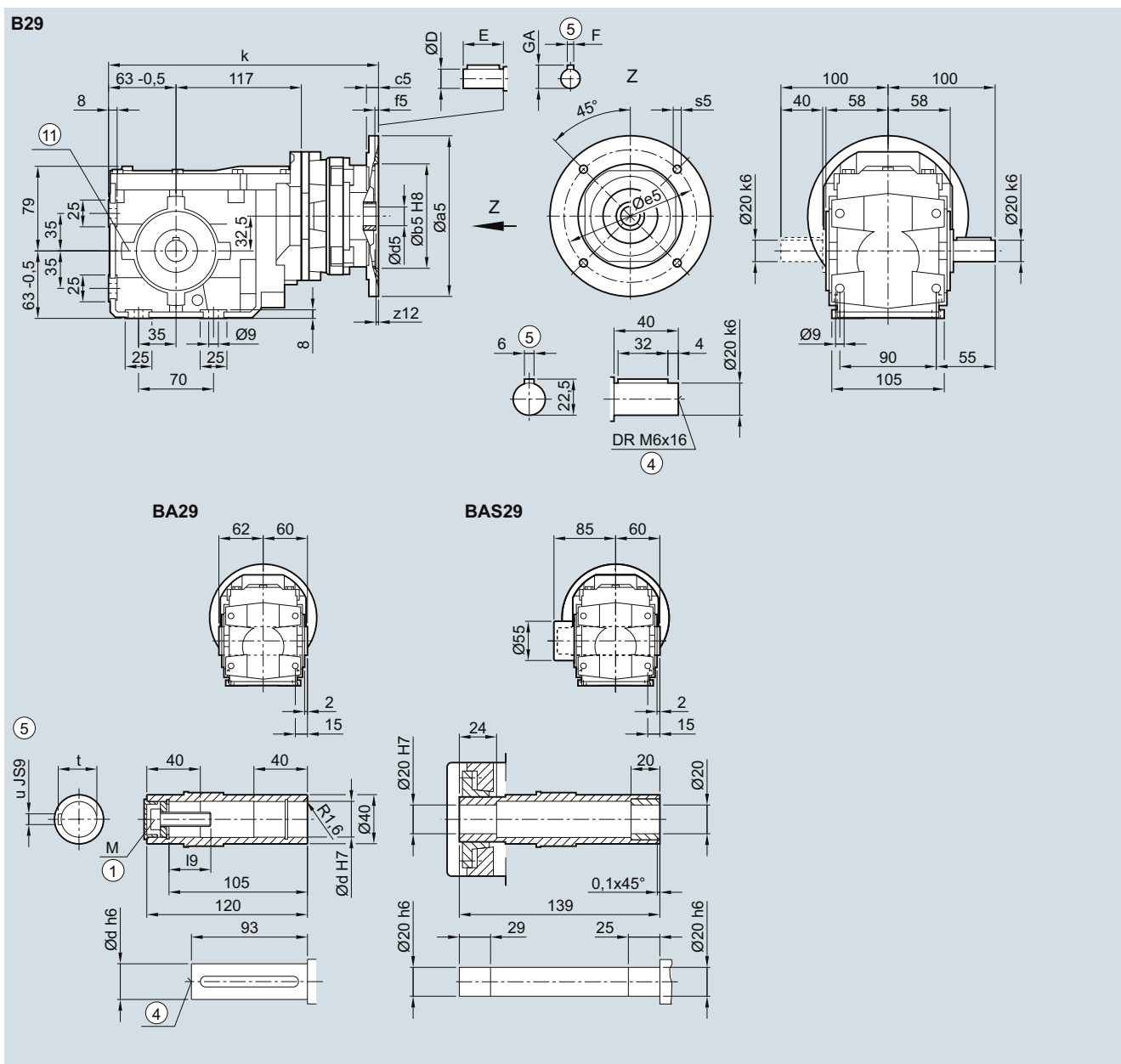

Shaft	d	l9	M	t	u								
	20	23.4	M6	22.8	6								
	25	27.6	M10	28.3	8								
Adapter	a5	b5	c5	f5	e5	s5	z12	d5	E	F	GA	k	
	63	140	95	12	4.5	115	M8	2.5	11	23	4	12.5	257.5
	71	160	110	12	4.5	130	M8	2.5	14	30	5	16.0	257.5
	80	200	130	15	4.5	165	M10	4.0	19	40	6	12.5	285.5
	90	200	130	15	4.5	165	M10	4.0	24	50	8	27.0	285.5
	100	250	180	14	5.0	215	M12x21	7.5	28	60	8	31.0	340.0

① ISO 4014

④ DIN 332

⑤ Feather key/keyway DIN 6885

⑩ Use bores only for housing flange design

SIMOGEAR Gearboxes

Bevel gearbox with adapter K4

Dimensions

B.F.29 gearbox in a flange-mounted design

BF030K4, BAF030K4, BAFS030K4

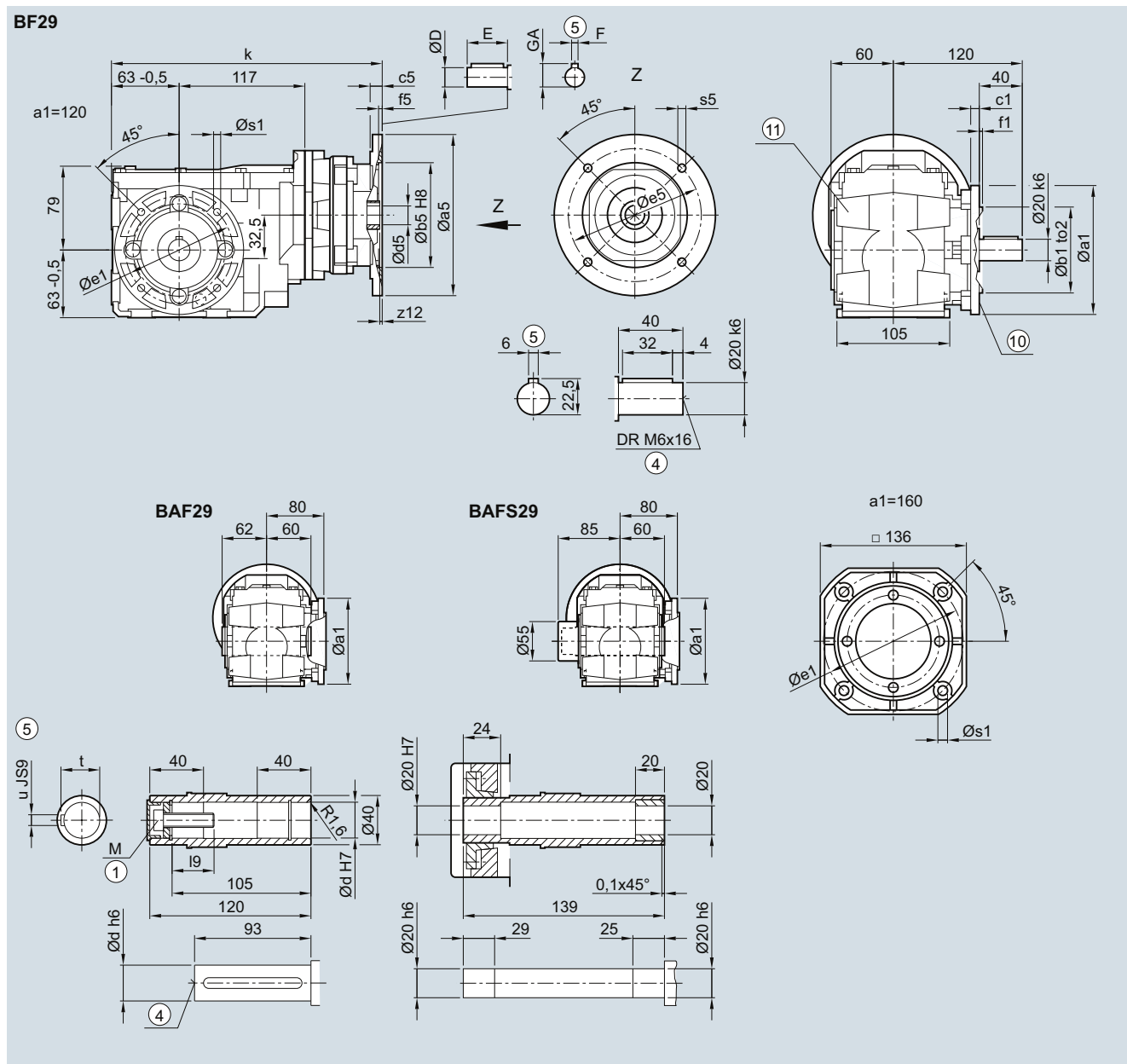

Flange	a1	b1	to2	c1	e1	f1	s1					
	120	80	j6	8	100	3.0	6.6					
	160	110	j6	9	130	3.5	9.0					
Shaft	d	l9	M	t	u							
	20	23.4	M6	22.8	6							
	25	27.6	M10	28.3	8							
Adapter	a5	b5	c5	f5	e5	s5	z12	d5/D	E	F	GA	k
63	140	95	12	4.5	115	M8	2.5	11	23	4	12.5	257.5
71	160	110	12	4.5	130	M8	2.5	14	30	5	16.0	257.5
80	200	130	15	4.5	165	M10	4.0	19	40	6	12.5	285.5
90	200	130	15	4.5	165	M10	4.0	24	50	8	27.0	285.5
100	250	180	14	5.0	215	M12x21	7.5	28	60	8	31.0	340.0

① ISO 4014

④ DIN 332

⑤ Feather key/keyway DIN 6885

⑪ Use bores only for foot-mounted design

B.Z.29 gearbox in a housing flange design

BZ030K4, BAZ030K4, BAZS030K4

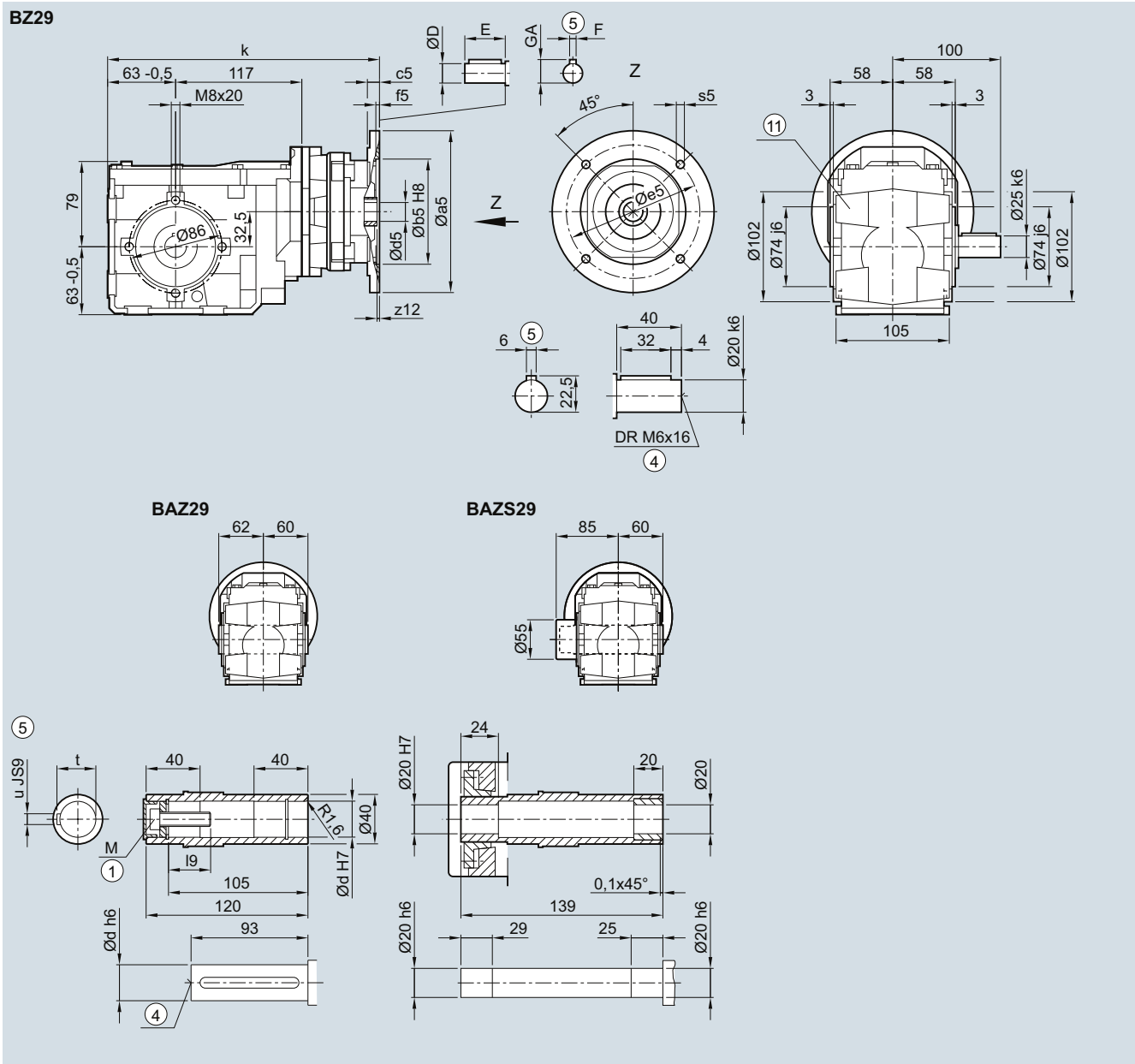

Shaft	d	l9	M	t	u
	20	23.4	M6	22.8	6
	25	27.6	M10	28.3	8

Adapter	a5	b5	c5	f5	e5	s5	z12	d5/D	E	F	GA	k
63	140	95	12	4.5	115	M8	2.5	11	23	4	12.5	257.5
71	160	110	12	4.5	130	M8	2.5	14	30	5	16.0	257.5
80	200	130	15	4.5	165	M10	4.0	19	40	6	12.5	285.5
90	200	130	15	4.5	165	M10	4.0	24	50	8	27.0	285.5
100	250	180	14	5.0	215	M12x21	7.5	28	60	8	31.0	340.0

① ISO 4014

④ DIN 332

⑤ Feather key/keyway DIN 6885

⑩ Use bores only for foot-mounted design

SIMOGEAR Gearboxes

Bevel gearbox with adapter K4

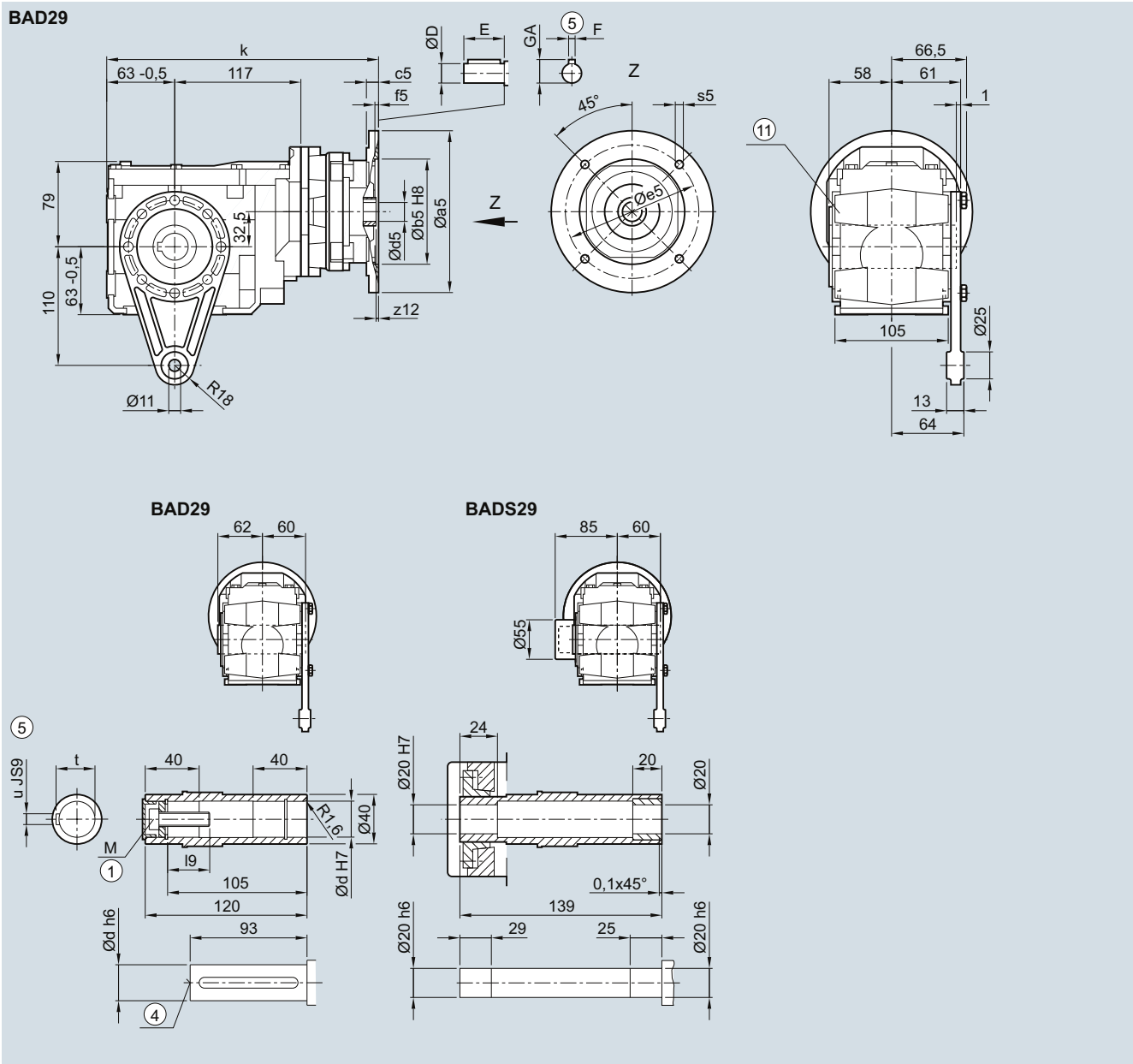
Dimensions**BAD.29 gearbox in a shaft-mounted design****BAD030K4, BADS030K4**

Shaft	d	l9	M	t	u
	20	23.4	M6	22.8	6
	25	27.6	M10	28.3	8

Adapter	a5	b5	c5	f5	e5	s5	z12	d5/D	E	F	GA	k
63	140	95	12	4.5	115	M8	2.5	11	23	4	12.5	257.5
71	160	110	12	4.5	130	M8	2.5	14	30	5	16.0	257.5
80	200	130	15	4.5	165	M10	4.0	19	40	6	12.5	285.5
90	200	130	15	4.5	165	M10	4.0	24	50	8	27.0	285.5
100	250	180	14	5.0	215	M12x21	7.5	28	60	8	31.0	340.0

① ISO 4014

④ DIN 332

⑤ Feather key/keyway DIN 6885

⑩ Use bores only for foot-mounted design

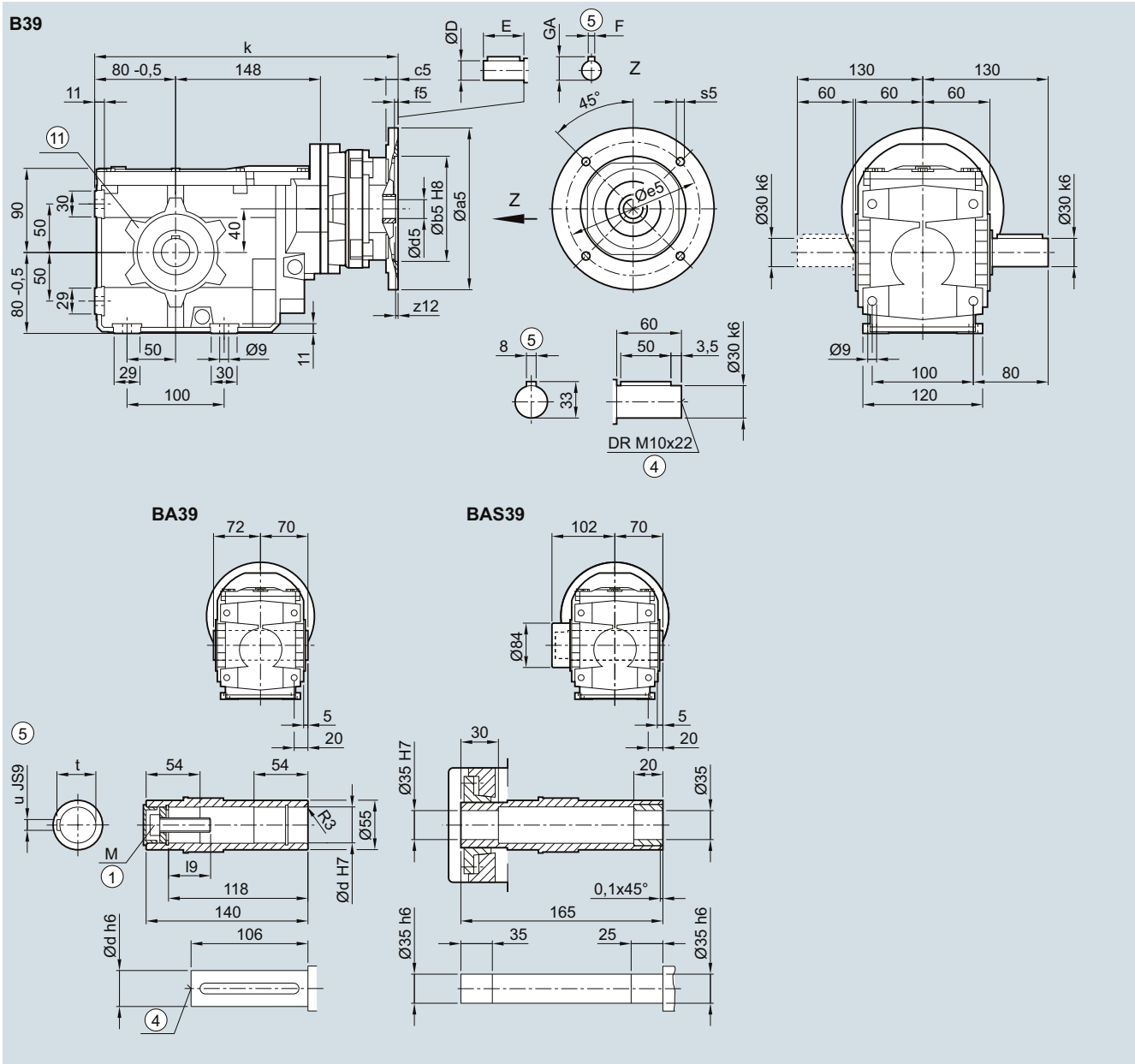
B..39 gearbox in a foot-mounted design
B030K4, BA030K4, BAS030K4

Shaft	d	l9	M	t	u
	30	32.6	M10	33.3	8
	35	37.0	M12	38.3	10
	40	47.75	M16	43.3	12

Adapter	a5	b5	c5	f5	e5	s5	z12	d5	E	F	GA	k
63	140	95	12	4.5	115	M8	2.5	11	23	4	12.5	305.5
71	160	110	12	4.5	130	M8	2.5	14	30	5	16.0	305.5
80	200	130	15	4.5	165	M10	4.0	19	40	6	12.5	333.5
90	200	130	15	4.5	165	M10	4.0	24	50	8	27.0	333.5
100	250	180	14	5.0	215	M12x21	7.5	28	60	8	31.0	388.0
112	250	180	14	5.0	215	M12x21	7.5	28	60	8	31.0	388.0

① ISO 4014

④ DIN 332

⑤ Feather key/keyway DIN 6885

⑩ Use bores only for housing flange design

SIMOGEAR Gearboxes

Bevel gearbox with adapter K4

Dimensions

B.F.39 gearbox in a flange-mounted design

BF030K4, BAF030K4, BAFS030K4

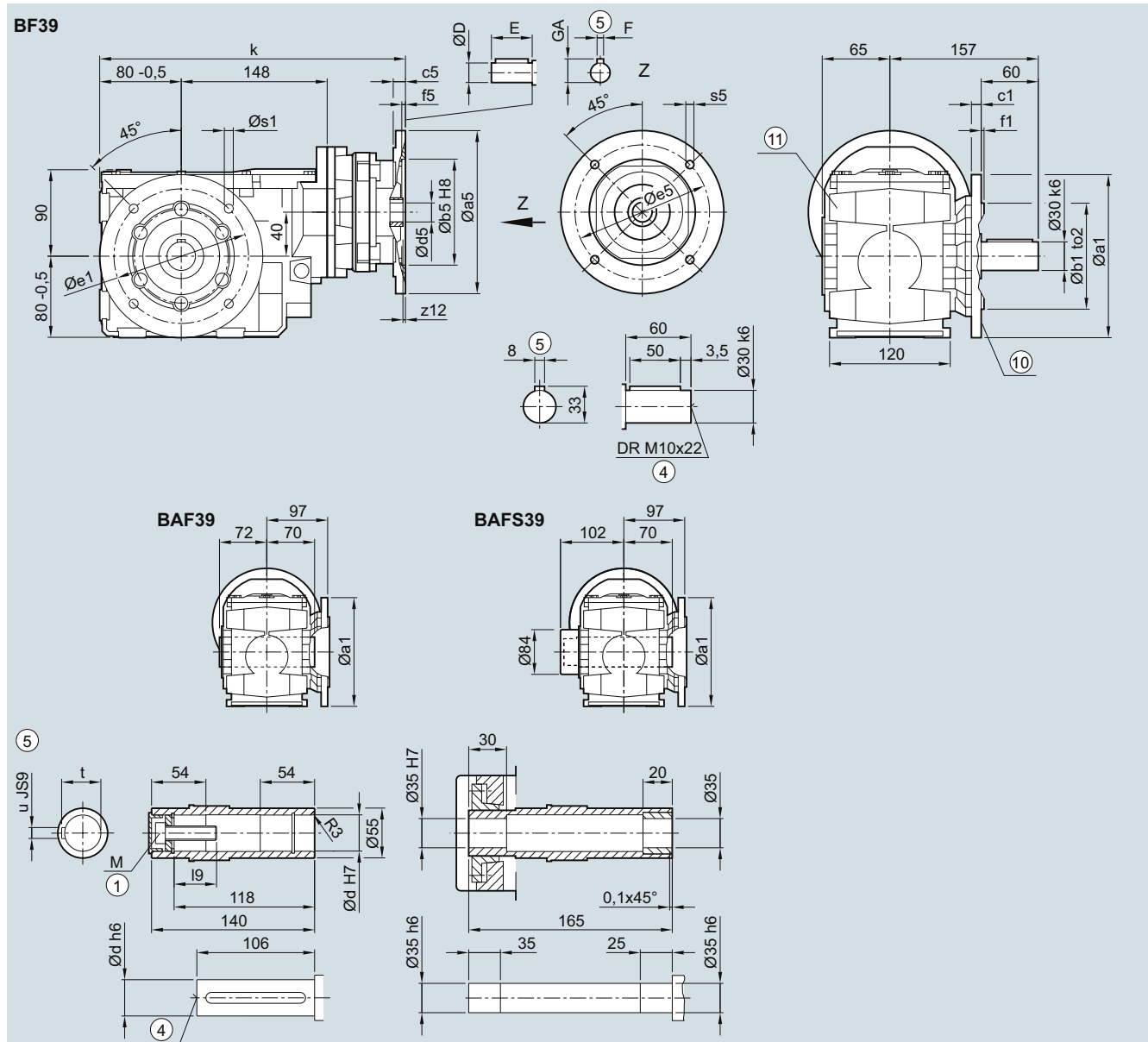

Flange	a1	b1	to2	c1	e1	f1	s1						
	160	110	j6	10	130	3.5	11.0						
	200	130	j6	12	165	3.5	11.0						
Shaft	d	I9	M	t	u								
	30	32.6	M10	33.3	8								
	35	37.0	M12	38.3	10								
	40	47.75	M16	43.3	12								
Adapter	a5	b5	c5	f5	e5	s5	z12	d5/D	E	F	GA	k	
	63	140	95	12	4.5	115	M8	2.5	11	23	4	12.5	305.5
	71	160	110	12	4.5	130	M8	2.5	14	30	5	16.0	305.5
	80	200	130	15	4.5	165	M10	4.0	19	40	6	12.5	333.5
	90	200	130	15	4.5	165	M10	4.0	24	50	8	27.0	333.5
	100	250	180	14	5.0	215	M12x21	7.5	28	60	8	31.0	388.0
	112	250	180	14	5.0	215	M12x21	7.5	28	60	8	31.0	388.0

① ISO 4014

④ DIN 332

⑤ Feather key/keyway DIN 6885

⑩ Use bores only for foot-mounted design

B.Z.39 in a housing flange design

BZ030K4, BAZ030K4, BAZS030K4

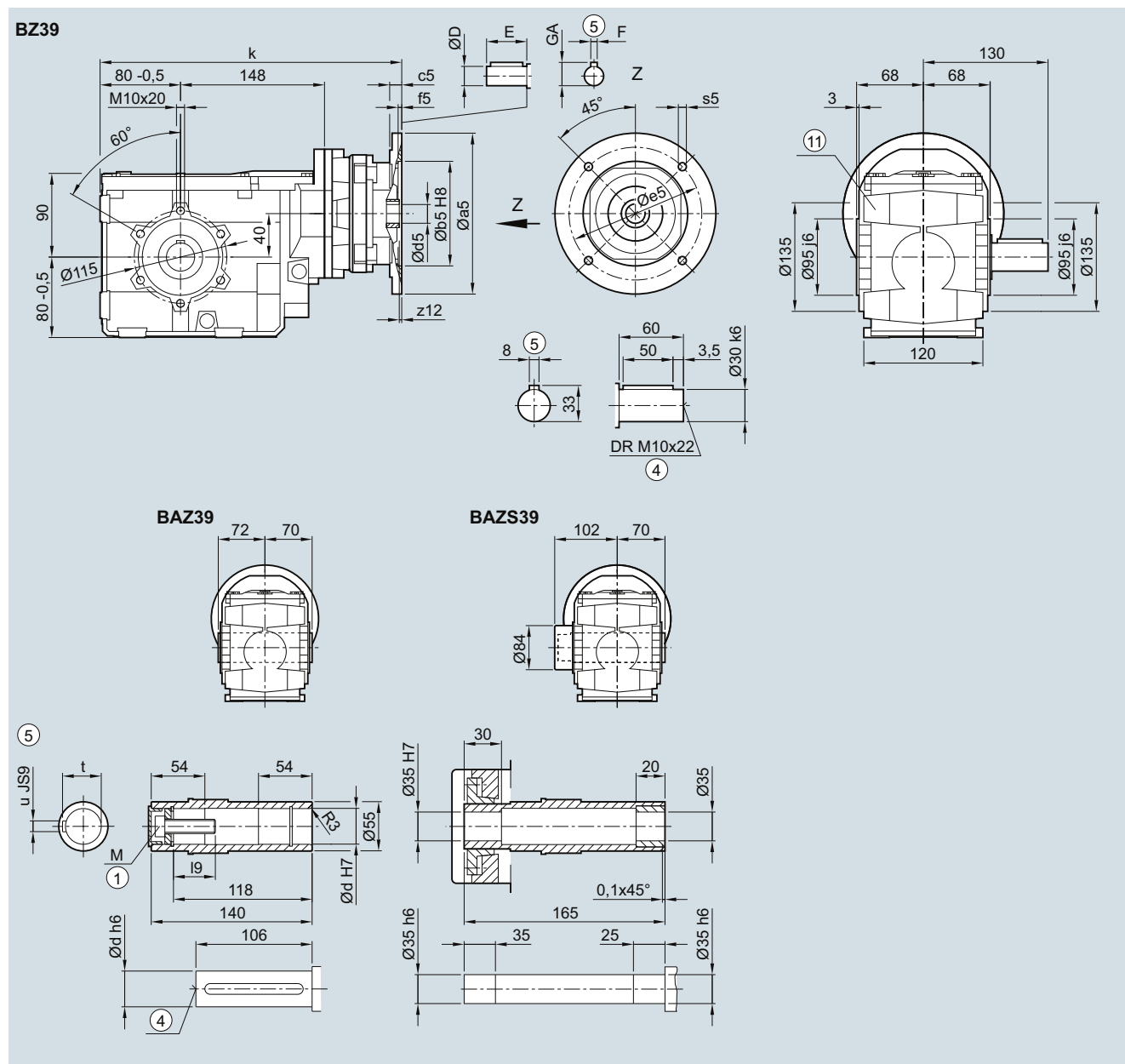

Shaft	d	I9	M	t	u
	30	32.6	M10	33.3	8
	35	37.0	M12	38.3	10
	40	47.75	M16	43.3	12

Adapter	a5	b5	c5	f5	e5	s5	z12	d5/D	E	F	GA	k
63	140	95	12	4.5	115	M8	2.5	11	23	4	12.5	305.5
71	160	110	12	4.5	130	M8	2.5	14	30	5	16.0	305.5
80	200	130	15	4.5	165	M10	4.0	19	40	6	12.5	333.5
90	200	130	15	4.5	165	M10	4.0	24	50	8	27.0	333.5
100	250	180	14	5.0	215	M12x21	7.5	28	60	8	31.0	388.0
112	250	180	14	5.0	215	M12x21	7.5	28	60	8	31.0	388.0

① ISO 4014

④ DIN 332

⑤ Feather key/keyway DIN 6885

⑩ Use bores only for foot-mounted design

SIMOGEAR Gearboxes

Bevel gearbox with adapter K4

Dimensions

BAD.39 gearbox in a shaft-mounted design

BAD030K4, BADS030K4

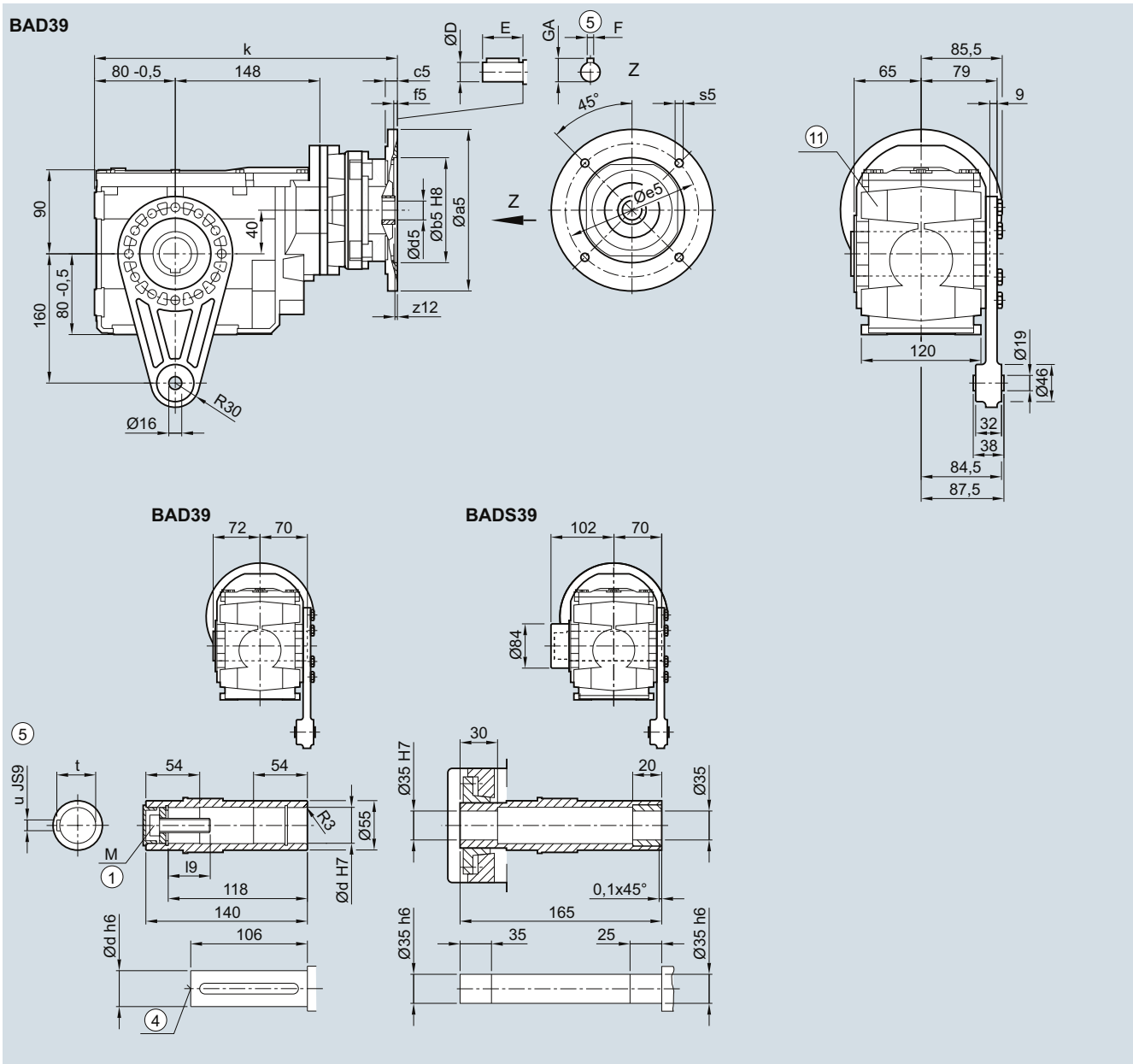

Shaft	d	I9	M	t	u
	30	32.6	M10	33.3	8
	35	37.0	M12	38.3	10
	40	47.75	M16	43.3	12

Adapter	a5	b5	c5	f5	e5	s5	z12	d5/D	E	F	GA	k
63	140	95	12	4.5	115	M8	2.5	11	23	4	12.5	305.5
71	160	110	12	4.5	130	M8	2.5	14	30	5	16.0	305.5
80	200	130	15	4.5	165	M10	4.0	19	40	6	12.5	333.5
90	200	130	15	4.5	165	M10	4.0	24	50	8	27.0	333.5
100	250	180	14	5.0	215	M12x21	7.5	28	60	8	31.0	388.0
112	250	180	14	5.0	215	M12x21	7.5	28	60	8	31.0	388.0

① ISO 4014

④ DIN 332

⑤ Feather key/keyway DIN 6885

⑩ Use bores only for foot-mounted design

B..49 gearbox in a foot-mounted design

B030K4, BA030K4, BAS030K4

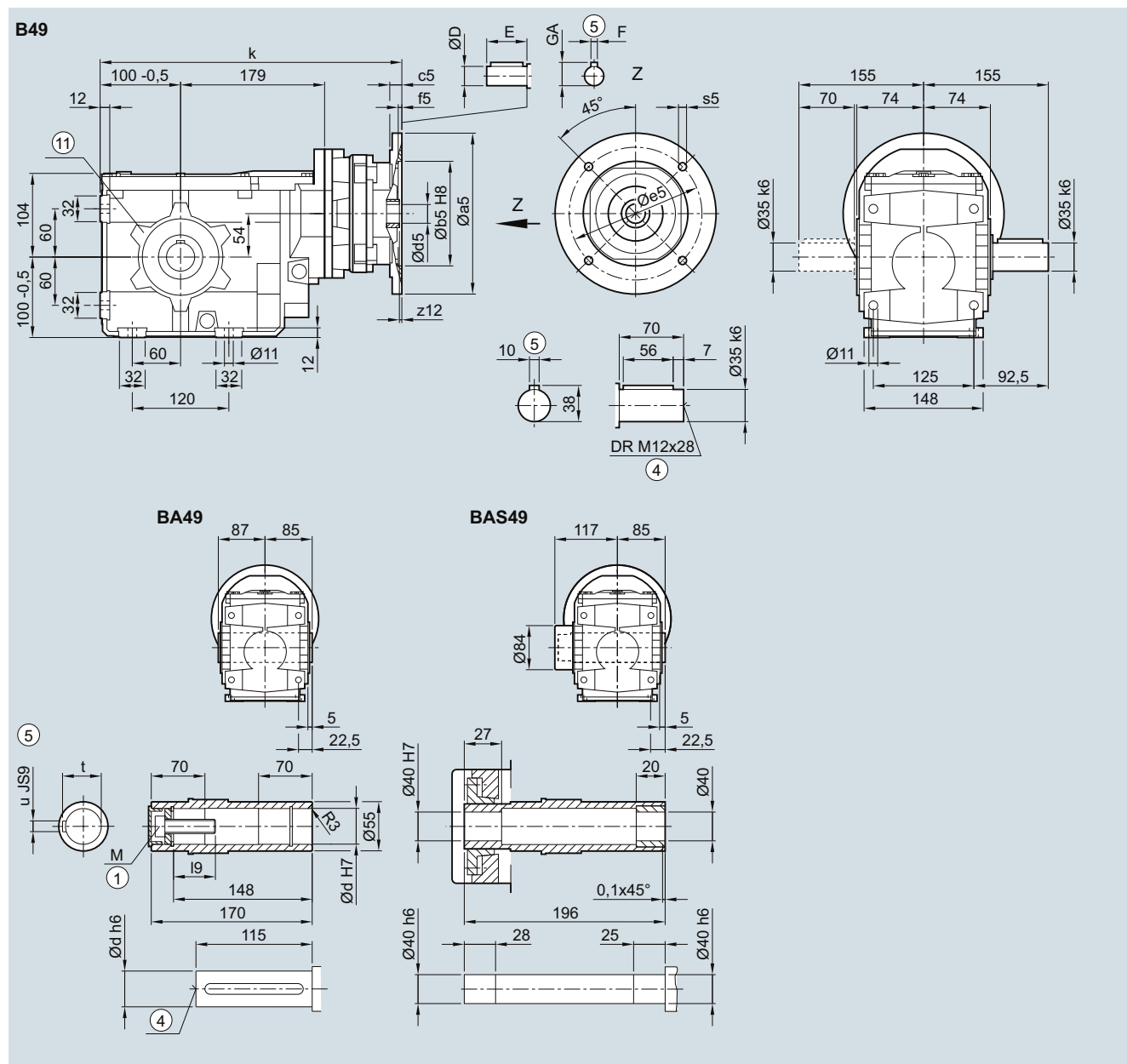

Shaft	d	I9	M	t	u							
	35	42	M12	38.3	10							
	40	47.75	M16	43.3	12							
Adapter	a5	b5	c5	f5	e5	s5	z12	d5/D	E	F	GA	k
63	140	95	12	4.5	115	M8	2.5	11	23	4	12.5	347.0
71	160	110	12	4.5	130	M8	2.5	14	30	5	16.0	347.0
80	200	130	15	4.5	165	M10	4.0	19	40	6	12.5	375.0
90	200	130	15	4.5	165	M10	4.0	24	50	8	27.0	375.0
100	250	180	14	5.0	215	M12x21	7.5	28	60	8	31.0	429.5
112	250	180	14	5.0	215	M12x21	7.5	28	60	8	31.0	429.5
132	300	230	12	6.0	265	M12x20	3.0	38	80	10	41.0	447.0

① ISO 4014

④ DIN 332

⑤ Feather key/keyway DIN 6885

⑩ Use bores only for housing flange design

SIMOGEAR Gearboxes

Bevel gearbox with adapter K4

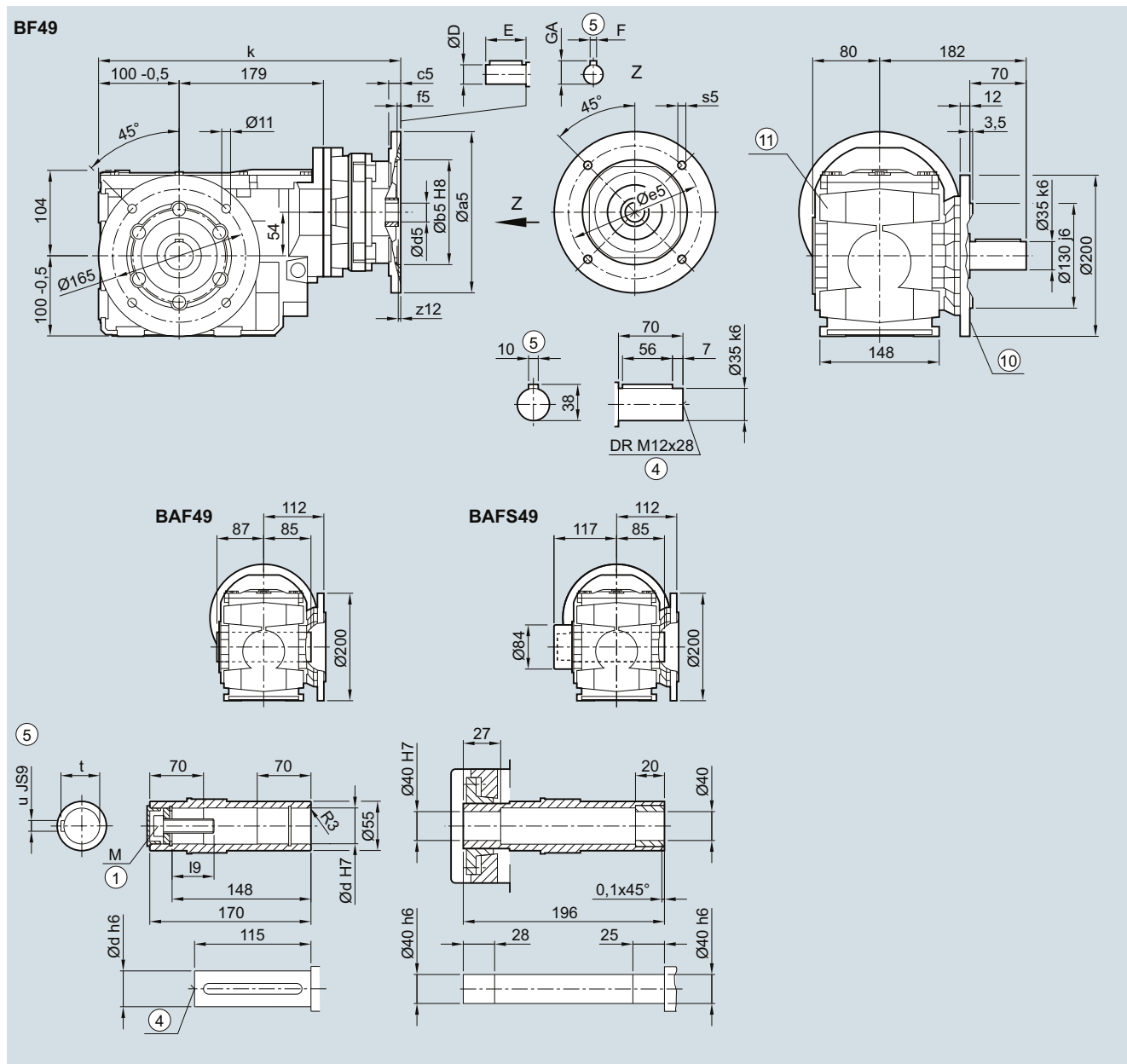
Dimensions**B.F.49 gearbox in a flange-mounted design****BF030K4, BAF030K4, BAFS030K4**

Shaft	d	l9	M	t	u
	35	42.0	M12	38.3	10
	40	47.75	M16	43.3	12

Adapter	a5	b5	c5	f5	e5	s5	z12	d5/D	E	F	GA	k
63	140	95	12	4.5	115	M8	2.5	11	23	4	12.5	347.0
71	160	110	12	4.5	130	M8	2.5	14	30	5	16.0	347.0
80	200	130	15	4.5	165	M10	4.0	19	40	6	12.5	375.0
90	200	130	15	4.5	165	M10	4.0	24	50	8	27.0	375.0
100	250	180	14	5.0	215	M12x21	7.5	28	60	8	31.0	429.5
112	250	180	14	5.0	215	M12x21	7.5	28	60	8	31.0	429.5
132	300	230	12	6.0	265	M12x20	3.0	38	80	10	41.0	447.0

① ISO 4014

④ DIN 332

⑤ Feather key/keyway DIN 6885

⑩ Use bores only for foot-mounted design

B.Z.49 in a housing flange design

BZ030K4, BAZ030K4, BAZS030K4

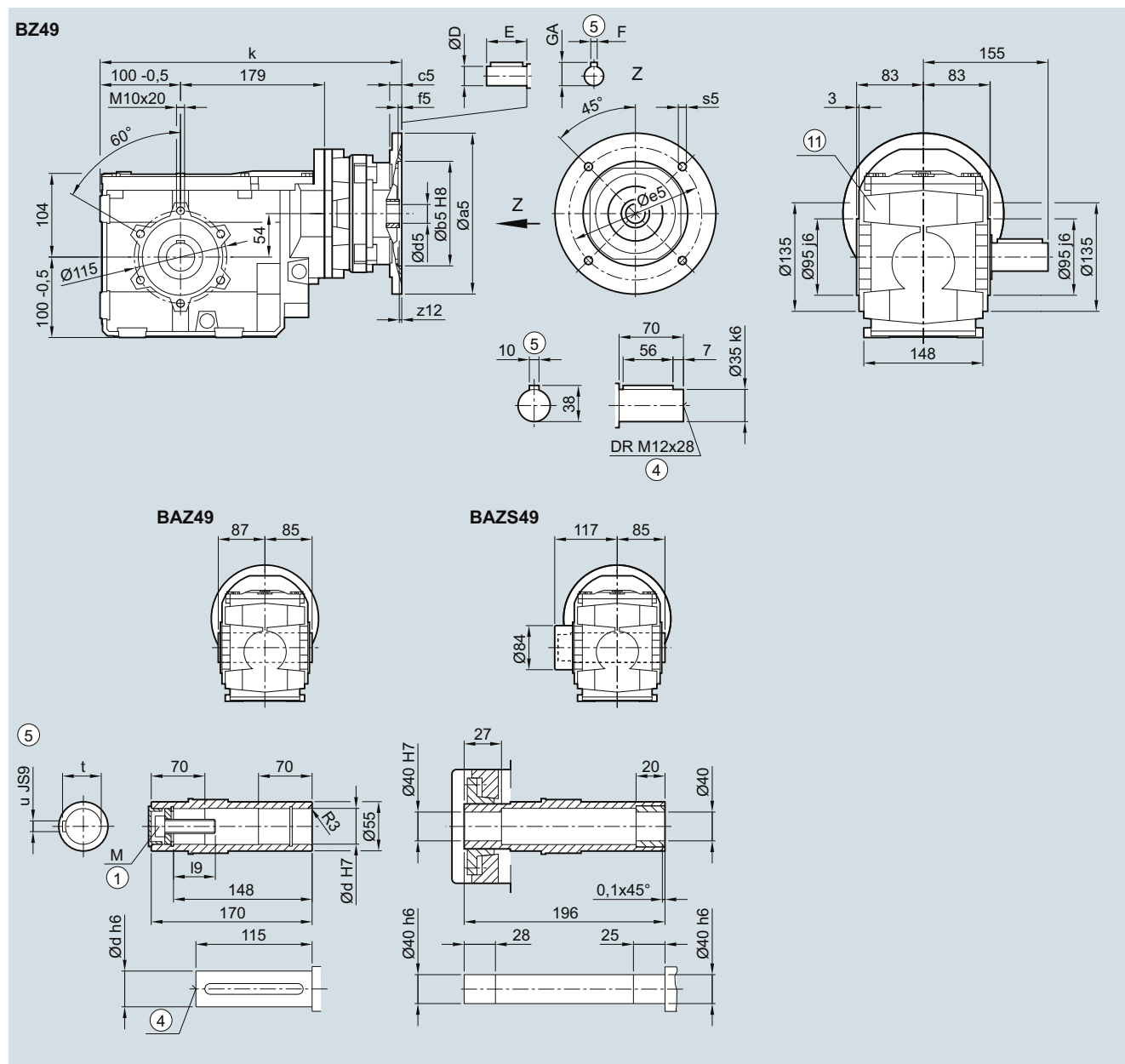

Shaft	d	l9	M	t	u
	35	42.0	M12	38.3	10
	40	47.75	M16	43.3	12

Adapter	a5	b5	c5	f5	e5	s5	z12	d5/D	E	F	GA	k
63	140	95	12	4.5	115	M8	2.5	11	23	4	12.5	347.0
71	160	110	12	4.5	130	M8	2.5	14	30	5	16.0	347.0
80	200	130	15	4.5	165	M10	4.0	19	40	6	12.5	375.0
90	200	130	15	4.5	165	M10	4.0	24	50	8	27.0	375.0
100	250	180	14	5.0	215	M12x21	7.5	28	60	8	31.0	429.5
112	250	180	14	5.0	215	M12x21	7.5	28	60	8	31.0	429.5
132	300	230	12	6.0	265	M12x20	3.0	38	80	10	41.0	447.0

① ISO 4014

④ DIN 332

⑤ Feather key/keyway DIN 6885

⑪ Use bores only for foot-mounted design

SIMOGEAR Gearboxes

Bevel gearbox with adapter K4

Dimensions

BAD.49 gearbox in a shaft-mounted design

BAD030K4, BADS030K4

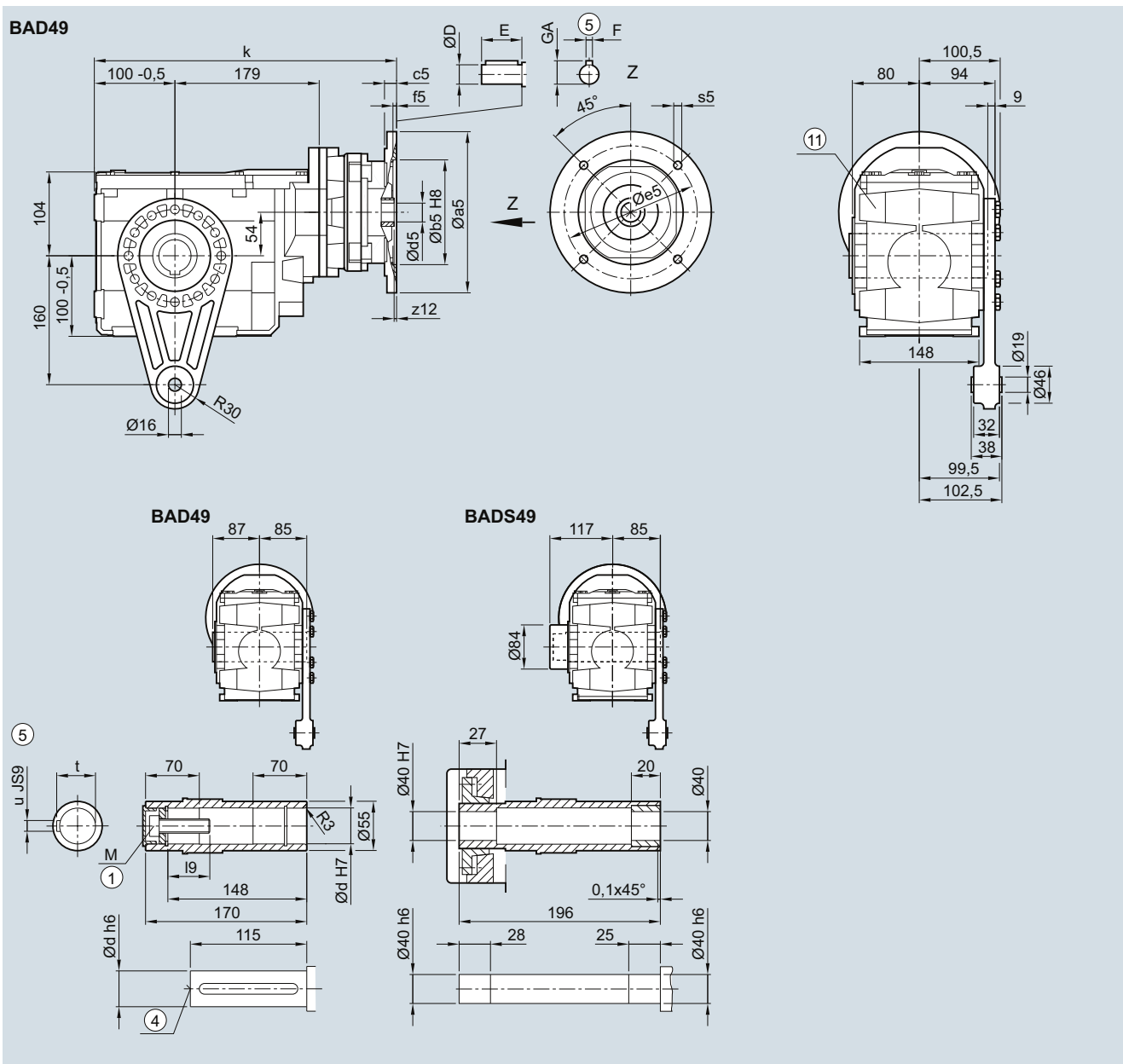

Shaft	d	l9	M	t	u
	35	42.0	M12	38.3	10
	40	47.75	M16	43.3	12

Adapter	a5	b5	c5	f5	e5	s5	z12	d5/D	E	F	GA	k
63	140	95	12	4.5	115	M8	2.0	11	23	4	12.5	341.0
71	160	110	12	4.5	130	M8	2.0	14	30	5	16.0	341.0
80	200	130	15	4.5	165	M10	4.0	19	40	6	12.5	375.0
90	200	130	15	4.5	165	M10	4.0	24	50	8	27.0	375.0
100	250	180	14	5.0	215	M12x21	7.5	28	60	8	31.0	429.5
112	250	180	14	5.0	215	M12x21	7.5	28	60	8	31.0	429.5
132	300	230	12	6.0	265	M12x20	4.0	38	80	10	41.0	447.0

① ISO 4014

④ DIN 332

⑤ Feather key/keyway DIN 6885

⑩ Use bores only for foot-mounted design

K.39 gearbox in a foot-mounted design

K030K4, KA030K4, KAS030K4, KAT030K4

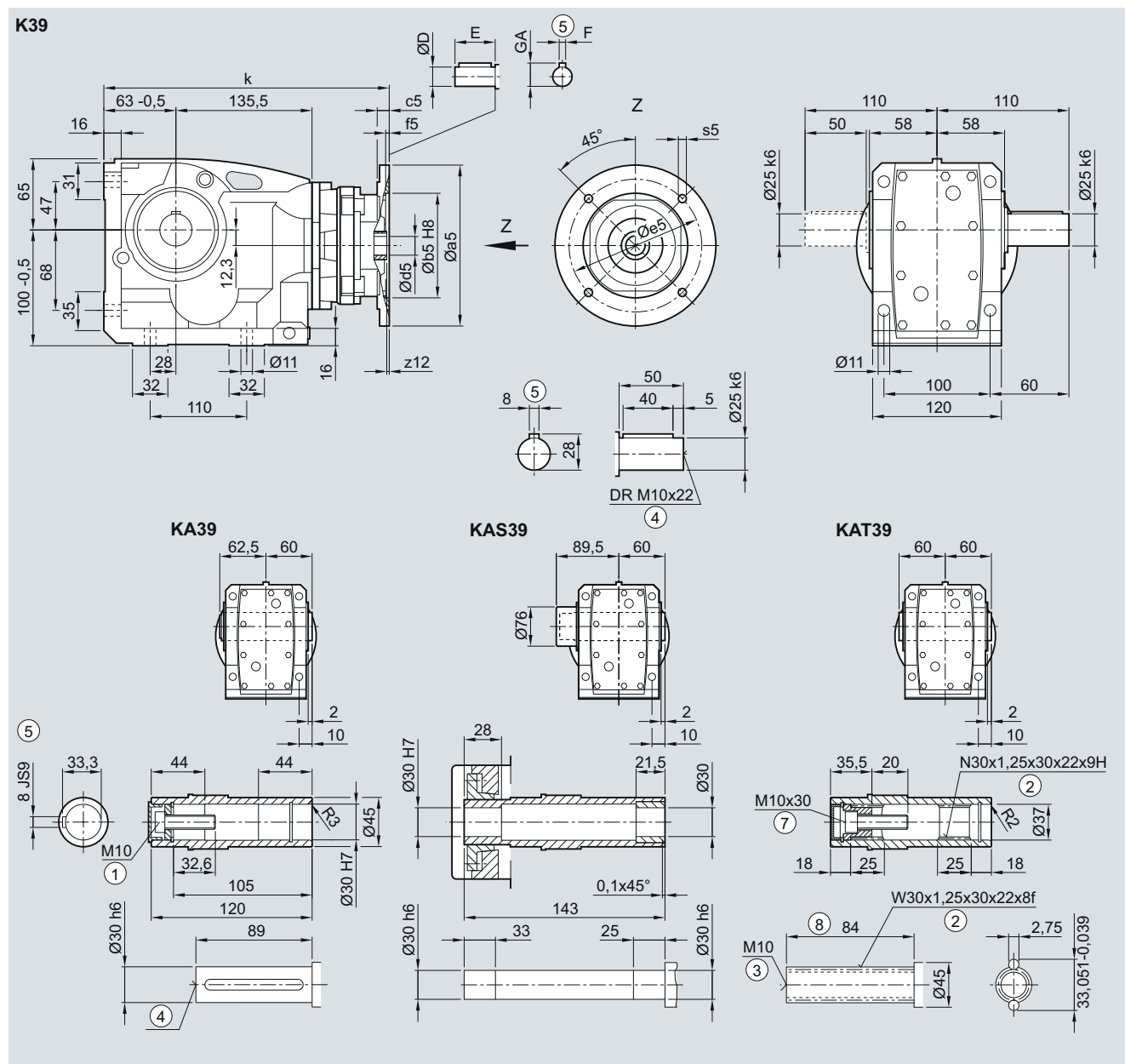

Adapter	a5	b5	c5	f5	e5	s5	z12	d5/D	E	F	GA	k
63	140	95	12	4.5	115	M8	2.5	11	23	4	12.5	275.5
71	160	110	12	4.5	130	M8	2.5	14	30	5	16.0	275.5
80	200	130	15	4.5	165	M10	4.0	19	40	6	12.5	303.5
90	200	130	15	4.5	165	M10	4.0	24	50	8	27.0	303.5
100	250	180	14	5.0	215	M12x21	7.5	28	60	8	31.0	358.0
112	250	180	14	5.0	215	M12x21	7.5	28	60	8	31.0	358.0

① ISO 4014 ② DIN 5480 ③ DIN 332-D ④ DIN 332 ⑤ Feather key/keyway DIN 6885 ⑦ ISO 4762 ⑥ Without locating shoulder +1 mm

SIMOGEAR Gearboxes

Bevel gearbox with adapter K4

Dimensions

K.F.39 gearbox in a flange-mounted design

KF030K4, KAF030K4, KAFS030K4, KAFT030K4

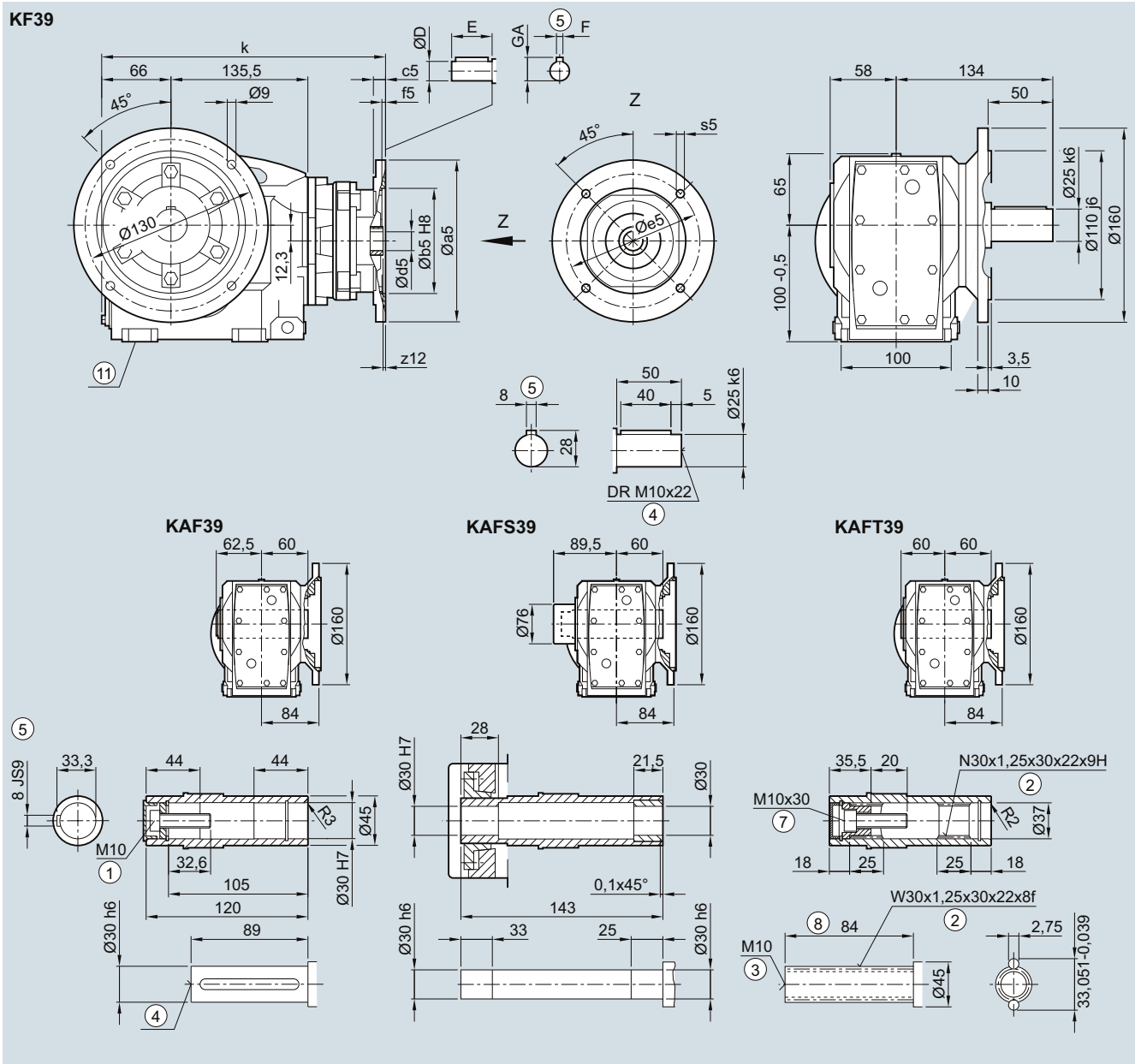

Adapter	a5	b5	c5	f5	e5	s5	z12	d5/D	E	F	GA	k
63	140	95	12	4.5	115	M8	2.5	11	23	4	12.5	278.5
71	160	110	12	4.5	130	M8	2.5	14	30	5	16.0	278.5
80	200	130	15	4.5	165	M10	4.0	19	40	6	12.5	306.5
90	200	130	15	4.5	165	M10	4.0	24	50	8	27.0	306.5
100	250	180	14	5.0	215	M12x21	7.5	28	60	8	31.0	361.0
112	250	180	14	5.0	215	M12x21	7.5	28	60	8	31.0	361.0

① ISO 4014

② DIN 5480

③ DIN 332-D

④ DIN 332

⑤ Feather key/keyway DIN 6885

⑥ ISO 4762

⑧ Without locating shoulder +1 mm

⑨ Use bores only for foot-mounted design

K.Z.39 gearbox in a housing flange design

KZ030K4, KAZ030K4, KAZS030K4, KAZT030K4

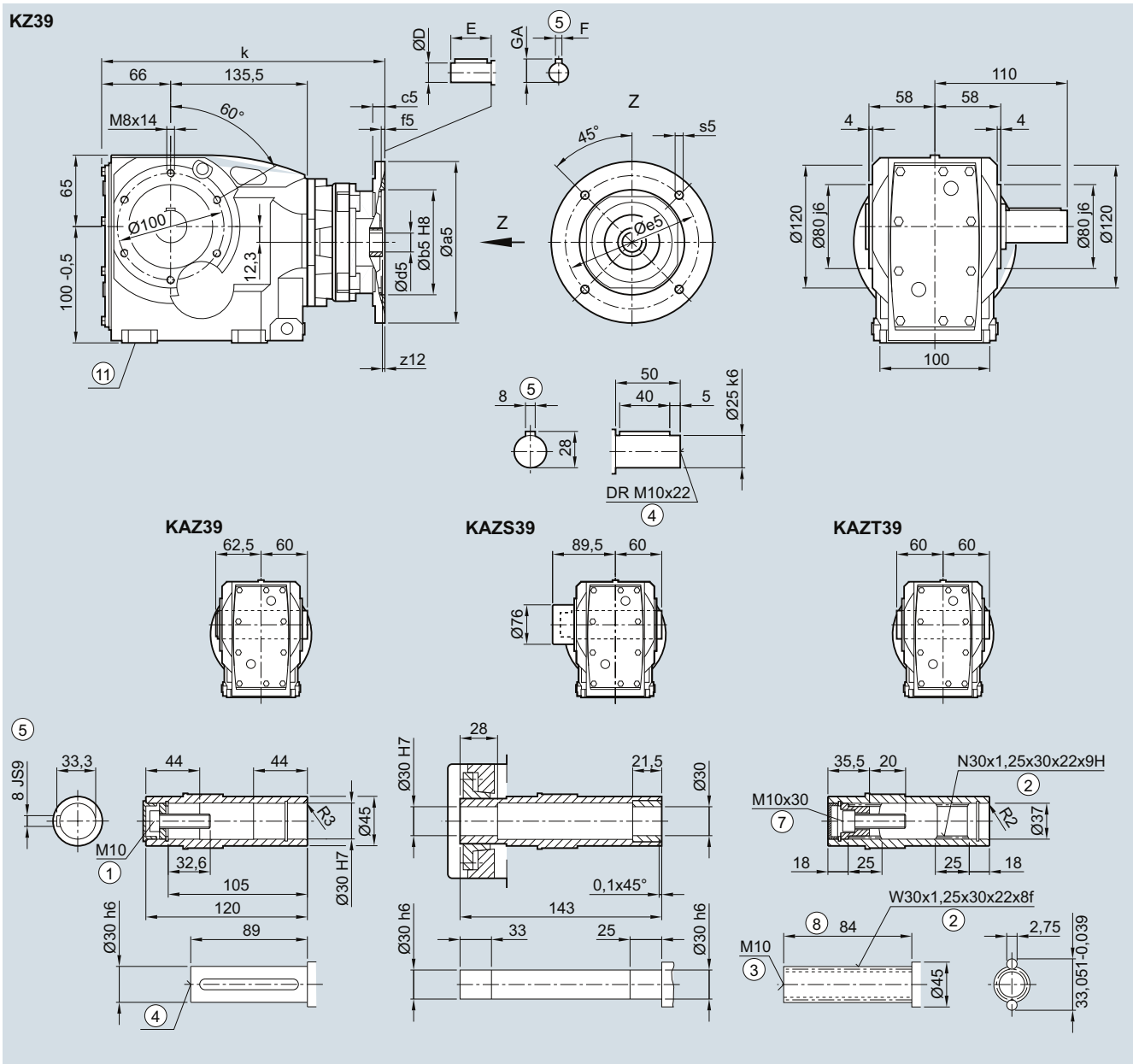

Adapter	a5	b5	c5	f5	e5	s5	z12	d5/D	E	F	GA	k
63	140	95	12	4.5	115	M8	2.5	11	23	4	12.5	278.5
71	160	110	12	4.5	130	M8	2.5	14	30	5	16.0	278.5
80	200	130	15	4.5	165	M10	4.0	19	40	6	12.5	306.5
90	200	130	15	4.5	165	M10	4.0	24	50	8	27.0	306.5
100	250	180	14	5.0	215	M12x21	7.5	28	60	8	31.0	361.0
112	250	180	14	5.0	215	M12x21	7.5	28	60	8	31.0	361.0

- ① ISO 4014 ② DIN 5480 ③ DIN 332-D ④ DIN 332 ⑤ Feather key/keyway DIN 6885
- ⑦ ISO 4762 ⑧ Without locating shoulder +1 mm ⑥ Use bores only for foot-mounted design

SIMOGEAR Gearboxes

Bevel gearbox with adapter K4

Dimensions

KAD.39 gearbox in a shaft-mounted design

KAD030K4, KADS030K4, KADT030K4

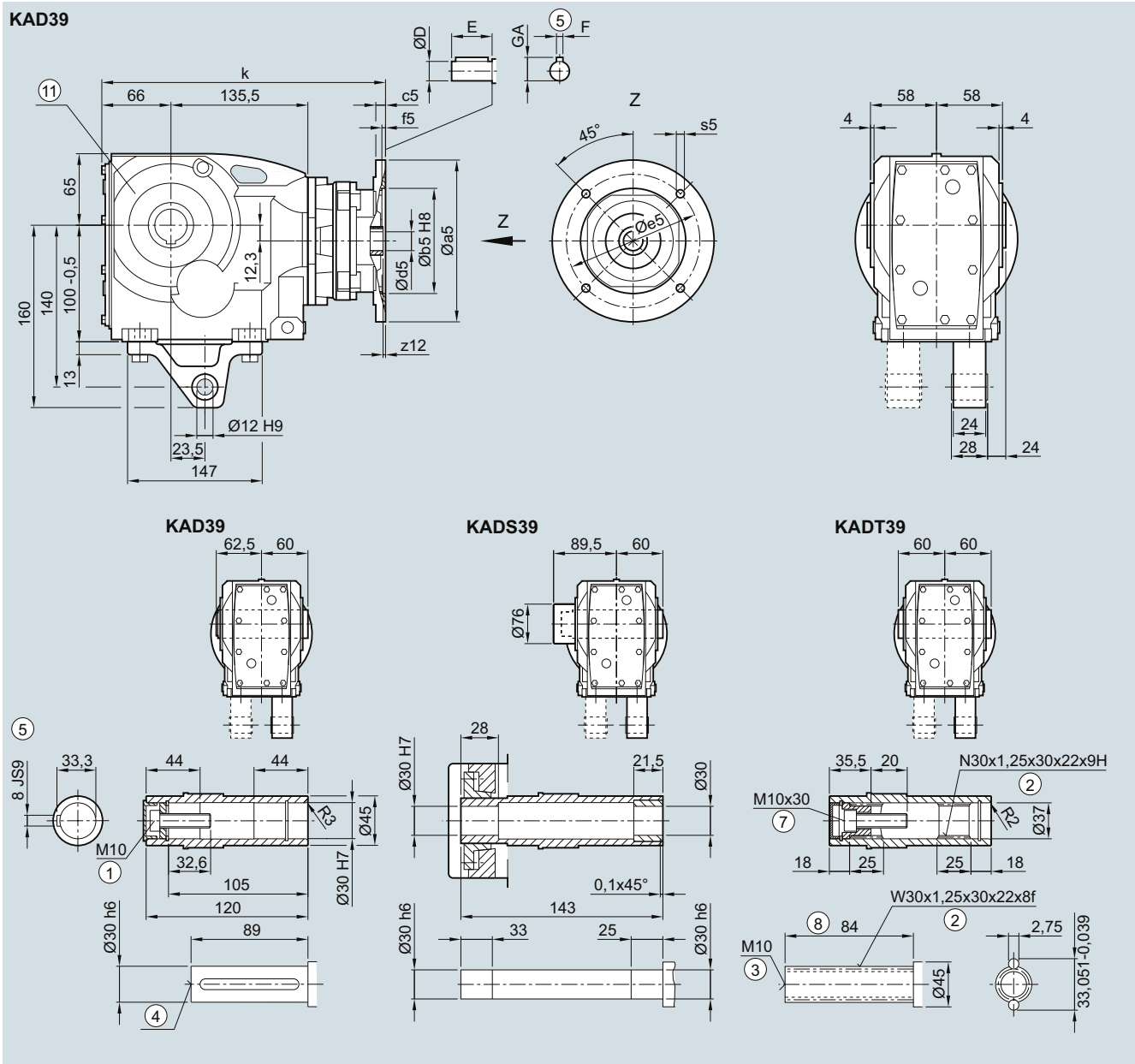

Adapter	a5	b5	c5	f5	e5	s5	z12	d5/D	E	F	GA	k
63	140	95	12	4.5	115	M8	2.5	11	23	4	12.5	278.5
71	160	110	12	4.5	130	M8	2.5	14	30	5	16.0	278.5
80	200	130	15	4.5	165	M10	4.0	19	40	6	12.5	306.5
90	200	130	15	4.5	165	M10	4.0	24	50	8	27.0	306.5
100	250	180	14	5.0	215	M12x21	7.5	28	60	8	31.0	361.0
112	250	180	14	5.0	215	M12x21	7.5	28	60	8	31.0	361.0

① ISO 4014

② DIN 5480

③ DIN 332-D

④ DIN 332

⑤ Feather key/keyway DIN 6885

⑦ ISO 4762

⑧ Without locating shoulder +1 mm

⑨ Use bores only for housing flange design

K.49 gearbox in a foot-mounted design

K030K4, KA030K4, KAS030K4, KAT030K4

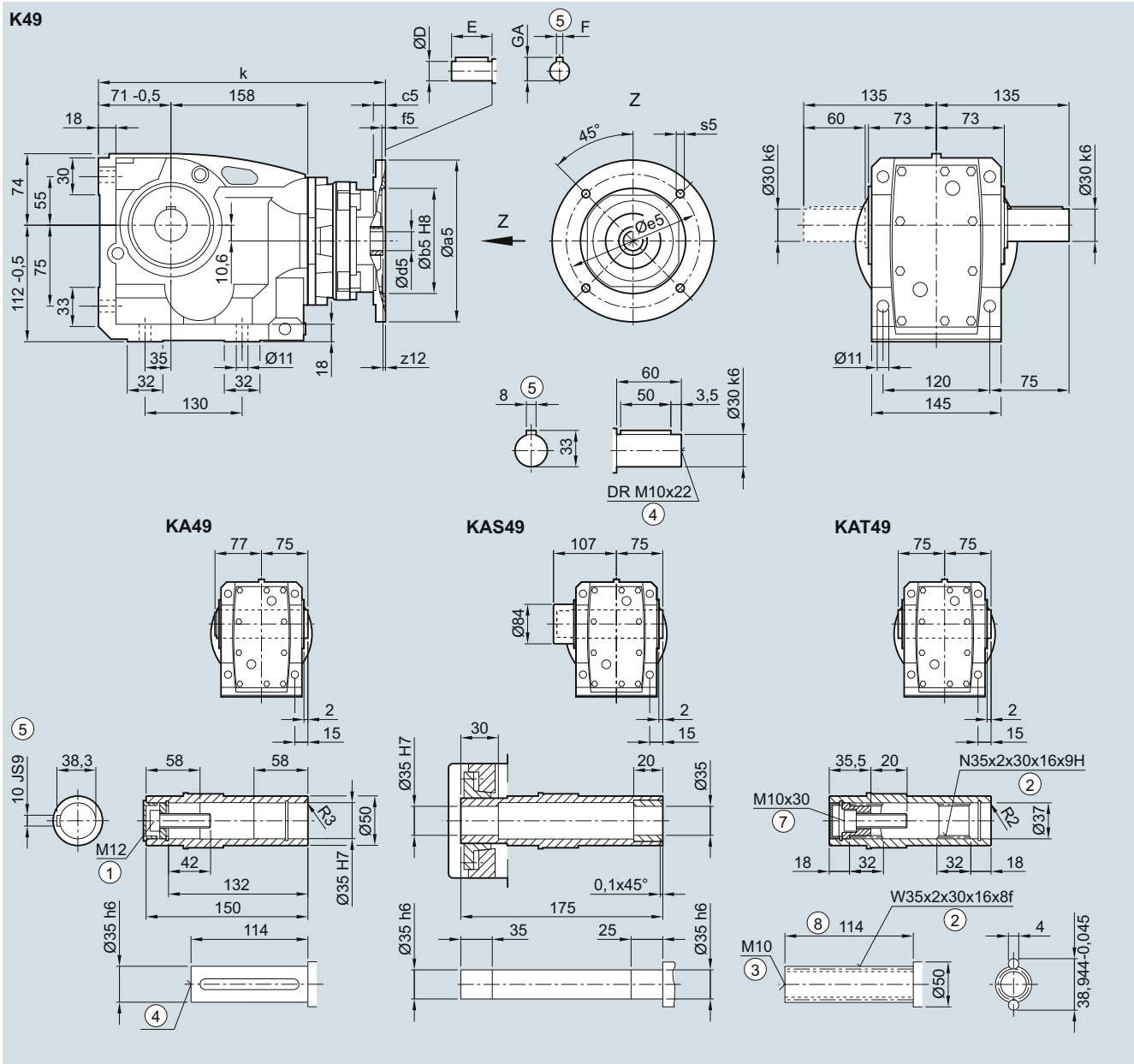

Adapter	a5	b5	c5	f5	e5	s5	z12	d5/D	E	F	GA	k
63	140	95	12	4.5	115	M8	2.5	11	23	4	12.5	297.0
71	160	110	12	4.5	130	M8	2.5	14	30	5	16.0	297.0
80	200	130	15	4.5	165	M10	4.0	19	40	6	12.5	325.0
90	200	130	15	4.5	165	M10	4.0	24	50	8	27.0	325.0
100	250	180	14	5	215	M12x21	7.5	28	60	8	31.0	379.5
112	250	180	14	5	215	M12x21	7.5	28	60	8	31.0	379.5
132	300	230	12	6	265	M12x20	3.0	38	80	10	41.0	397.0

① ISO 4014 ② DIN 5480 ③ DIN 332-D ④ DIN 332 ⑤ Feather key/keyway DIN 6885 ⑦ ISO 4762 ⑥ Without locating shoulder +1 mm

SIMOGEAR Gearboxes

Bevel gearbox with adapter K4

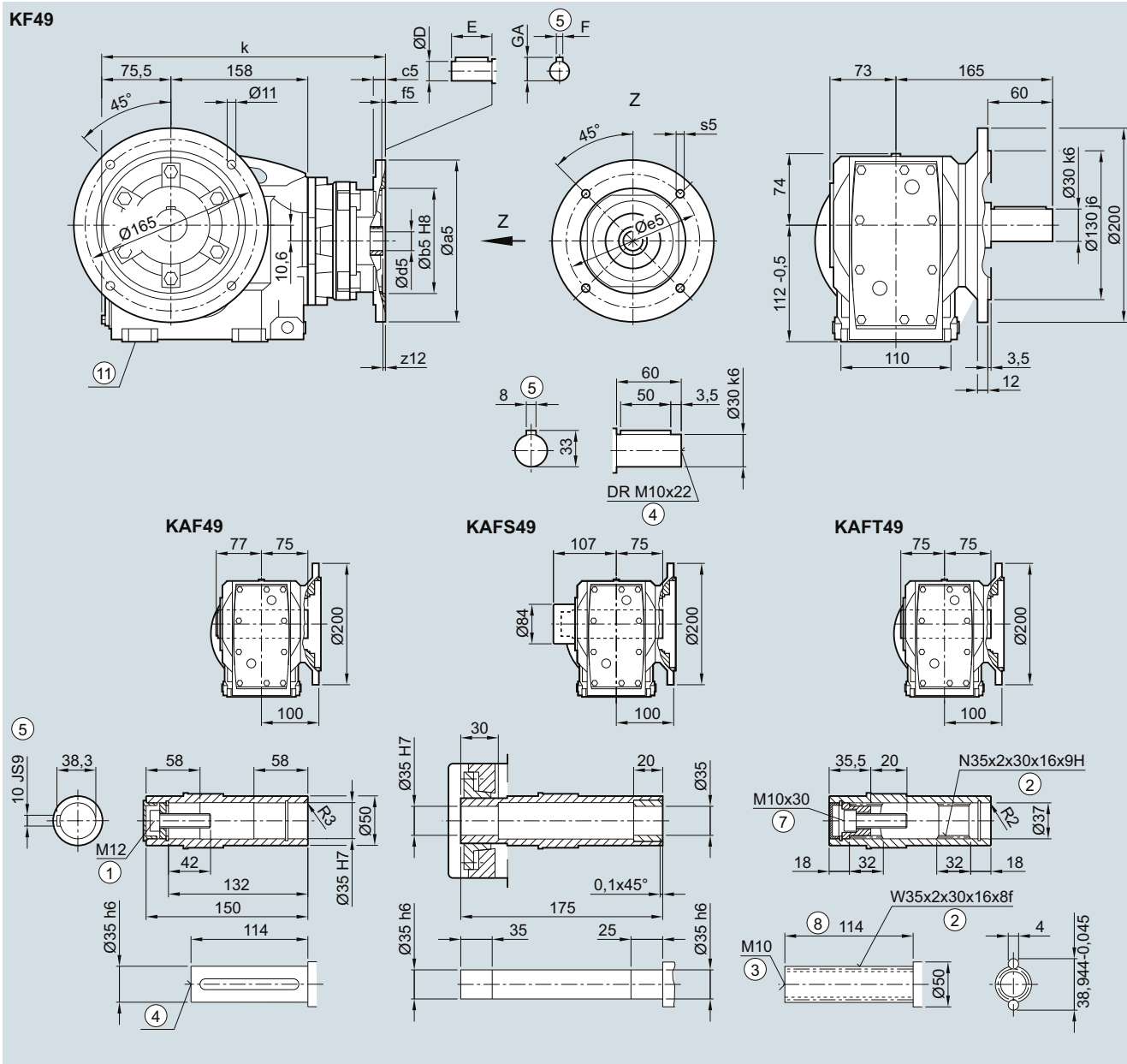
Dimensions**K.F.49 gearbox in a flange-mounted design****KF030K4, KAF030K4, KAFS030K4, KAFT030K4**

Adapter	a5	b5	c5	f5	e5	s5	z12	d5/D	E	F	GA	k
63	140	95	12	4.5	115	M8	2.5	11	23	4	12.5	301.5
71	160	110	12	4.5	130	M8	2.5	14	30	5	16.0	301.5
80	200	130	15	4.5	165	M10	4.0	19	40	6	12.5	329.5
90	200	130	15	4.5	165	M10	4.0	24	50	8	27.0	329.5
100	250	180	14	5.0	215	M12x21	7.5	28	60	8	31.0	384.0
112	250	180	14	5.0	215	M12x21	7.5	28	60	8	31.0	384.0
132	300	230	12	6.0	265	M12x20	3.0	38	80	10	41.0	401.5

① ISO 4014

② DIN 5480

③ DIN 332-D

④ DIN 332

⑤ Feather key/keyway DIN 6885

⑥ ISO 4762

⑦ Without locating shoulder +1 mm

⑧ Use bores only for foot-mounted design

K.Z.49 in a housing flange design

KZ030K4, KAZ030K4, KAZS030K4, KAZT030K4

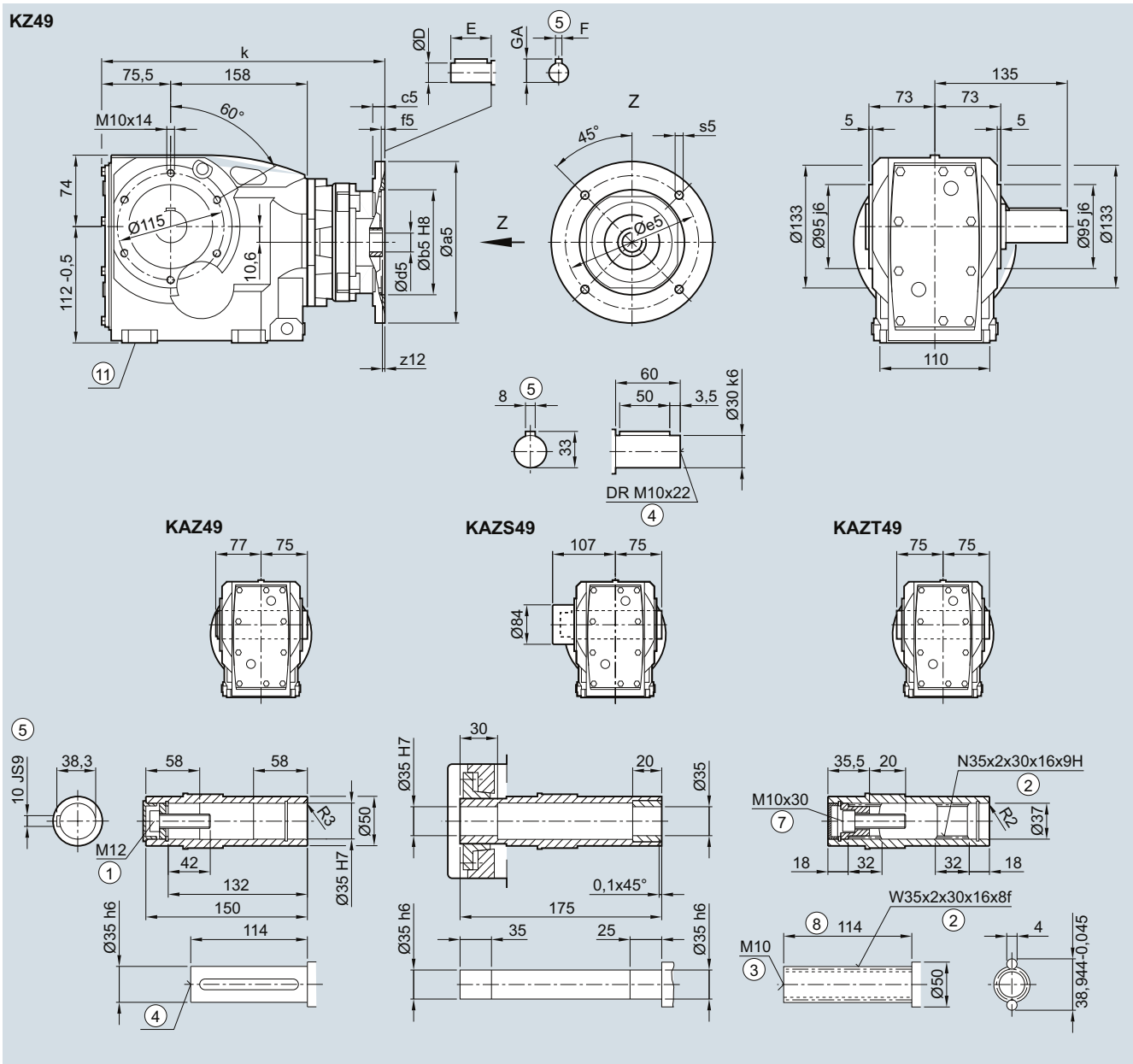

5

Adapter	a5	b5	c5	f5	e5	s5	z12	d5/D	E	F	GA	k
63	140	95	12	4.5	115	M8	2.5	11	23	4	12.5	301.5
71	160	110	12	4.5	130	M8	2.5	14	30	5	16.0	301.5
80	200	130	15	4.5	165	M10	4.0	19	40	6	12.5	329.5
90	200	130	15	4.5	165	M10	4.0	24	50	8	27.0	329.5
100	250	180	14	5.0	215	M12x21	7.5	28	60	8	31.0	384.0
112	250	180	14	5.0	215	M12x21	7.5	28	60	8	31.0	384.0
132	300	230	12	6.0	265	M12x20	3.0	38	80	10	41.0	401.5

① ISO 4014 ② DIN 5480 ③ DIN 332-D ④ DIN 332 ⑤ Feather key/keyway DIN 6885
 ⑦ ISO 4762 ⑧ Without locating shoulder +1 mm ⑨ Use bores only for foot-mounted design

SIMOGEAR Gearboxes

Bevel gearbox with adapter K4

Dimensions

KAD.49 gearbox in a shaft-mounted design

KAD030K4, KADS030K4, KADT030K4

KAD49

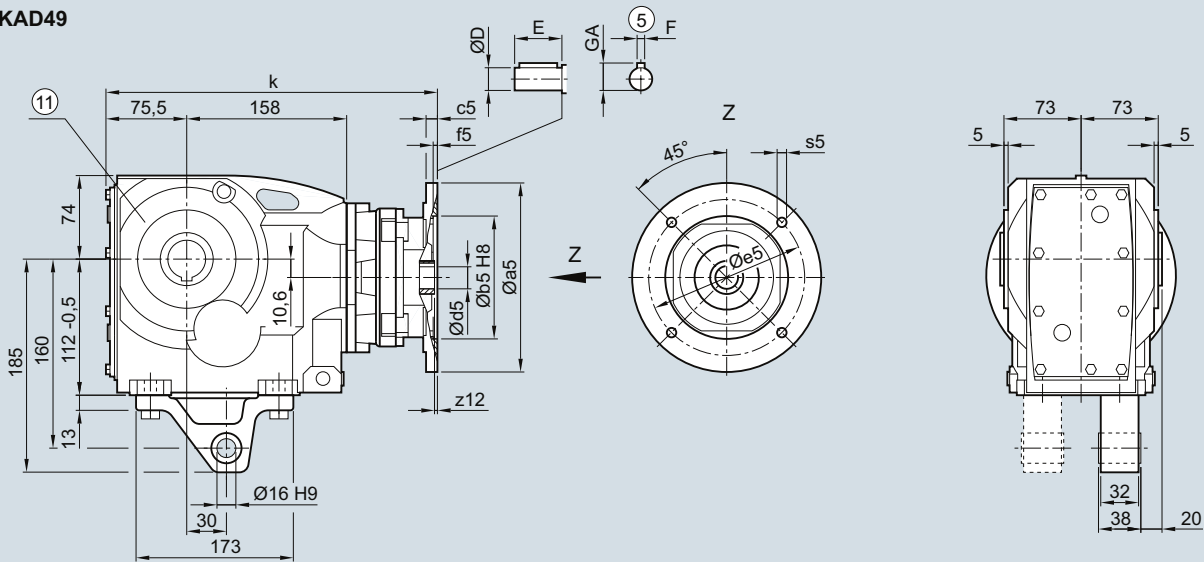

KAD49

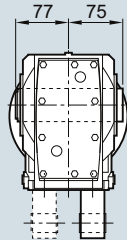

KADS49

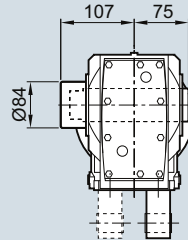

KADT49

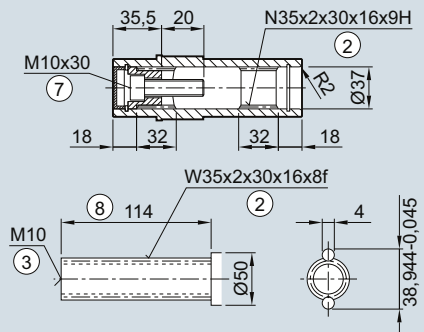
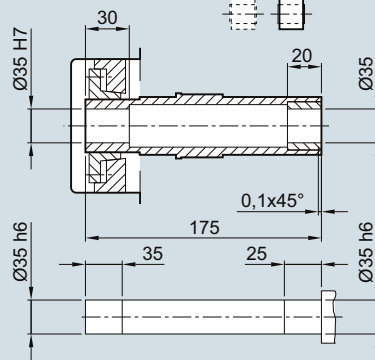
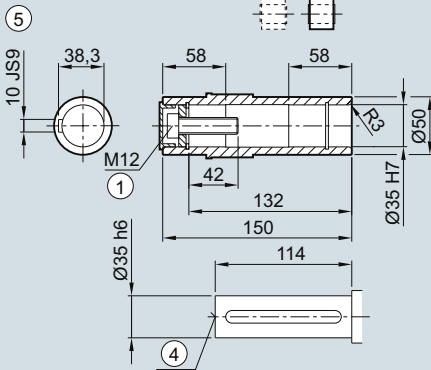
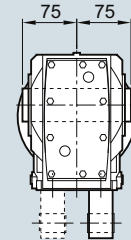

Adapter	a5	b5	c5	f5	e5	s5	z12	d5/D	E	F	GA	k
63	140	95	12	4.5	115	M8	2.5	11	23	4	12.5	301.5
71	160	110	12	4.5	130	M8	2.5	14	30	5	16.0	301.5
80	200	130	15	4.5	165	M10	4.0	19	40	6	12.5	329.5
90	200	130	15	4.5	165	M10	4.0	24	50	8	27.0	329.5
100	250	180	14	5.0	215	M12x21	7.5	28	60	8	31.0	384.0
112	250	180	14	5.0	215	M12x21	7.5	28	60	8	31.0	384.0
132	300	230	12	6.0	265	M12x20	3.0	38	80	10	41.0	401.5

① ISO 4014
② ISO 4762

③ DIN 5480
④ Without locating shoulder +1 mm

⑤ DIN 332-D

⑥ DIN 332

⑦ Feather key/keyway DIN 6885

⑧ Use bores only for housing flange design

K.69 gearbox in a foot-mounted design

K030K4, KA030K4, KAS030K4, KAT030K4

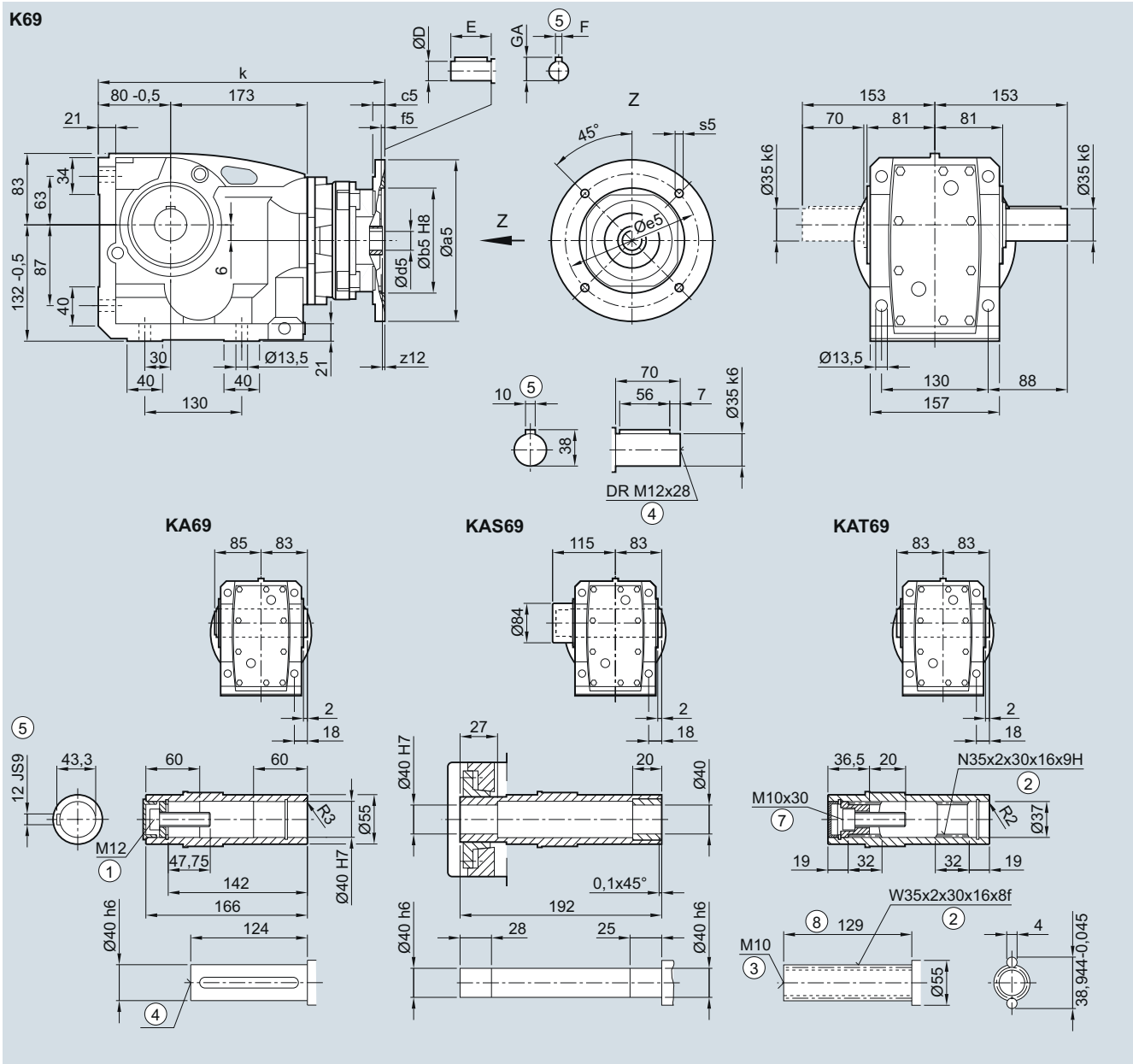

5

Adapter	a5	b5	c5	f5	e5	s5	z12	d5/D	E	F	GA	k
63	140	95	12	4.5	115.0	M8	2.5	11	23	4	12.5	321.0
71	160	110	12	4.5	130.0	M8	2.5	14	30	5	16.0	321.0
80	200	130	15	4.5	165.0	M10	4.0	19	40	6	12.5	349.0
90	200	130	15	4.5	165.0	M10	4.0	24	50	8	27.0	349.0
100	250	180	14	5	215.0	M12x21	7.5	28	60	8	31.0	403.5
112	250	180	14	5	215.0	M12x21	7.5	28	60	8	31.0	403.5
132	300	230	12	6	265.0	M12x20	3.0	38	80	10	41.0	421.0

① ISO 4014 ② DIN 5480 ③ DIN 332-D ④ DIN 332 ⑤ Feather key/keyway DIN 6885 ⑦ ISO 4762 ⑥ Without locating shoulder +1 mm

SIMOGEAR Gearboxes

Bevel gearbox with adapter K4

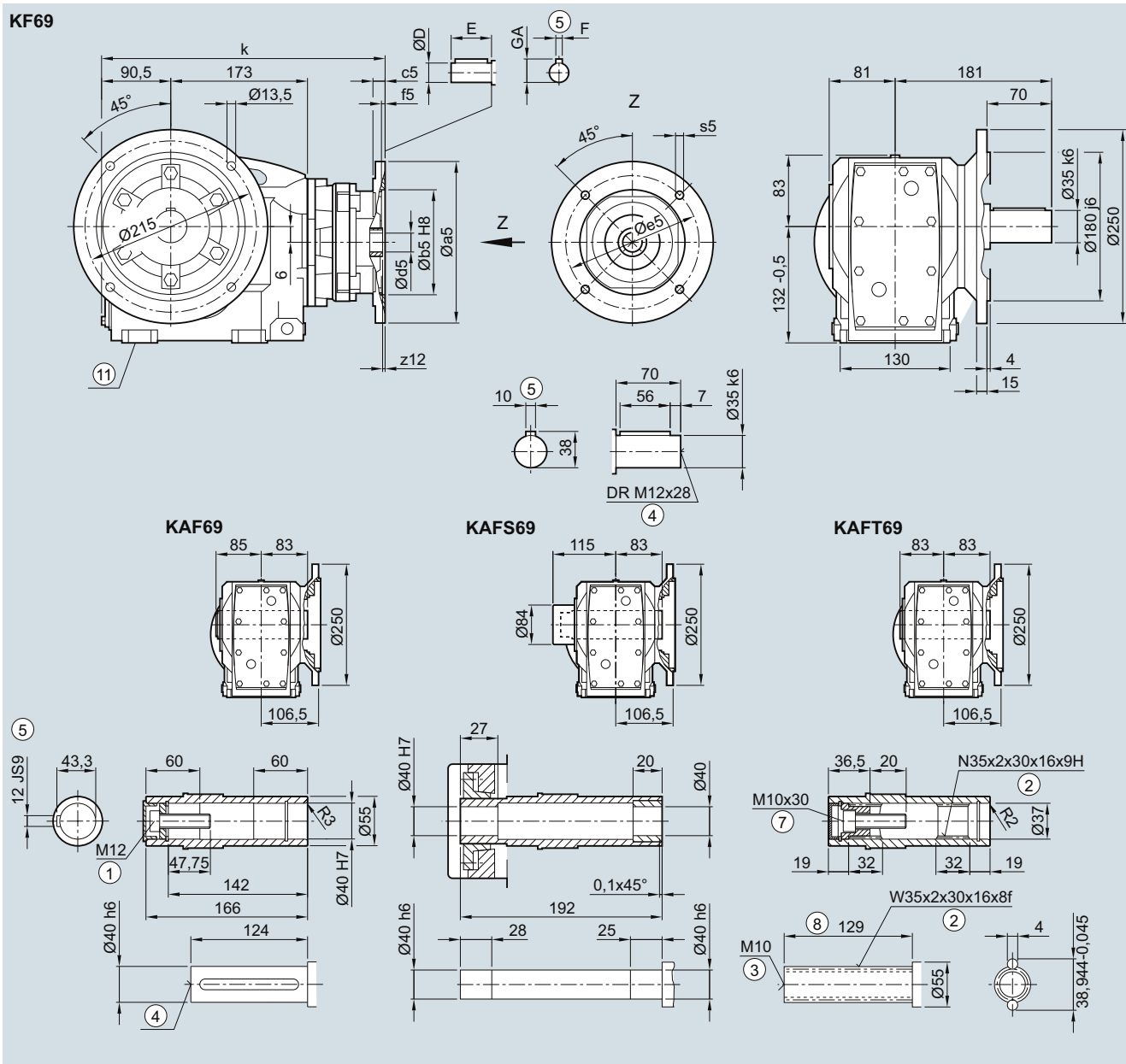
Dimensions**K.F.69 gearbox in a flange-mounted design****KF030K4, KAF030K4, KAFS030K4, KAFT030K4**

Adapter	a5	b5	c5	f5	e5	s5	z12	d5/D	E	F	GA	k
63	140	95	12	4.5	115	M8	2.5	11	23	4	12.5	331.5
71	160	110	12	4.5	130	M8	2.5	14	30	5	16.0	331.5
80	200	130	15	4.5	165	M10	4.0	19	40	6	12.5	359.5
90	200	130	15	4.5	165	M10	4.0	24	50	8	27.0	359.5
100	250	180	14	5.0	215	M12x21	7.5	28	60	8	31.0	414.0
112	250	180	14	5.0	215	M12x21	7.5	28	60	8	31.0	414.0
132	300	230	12	6.0	265	M12x20	3.0	38	80	10	41.0	431.5

① ISO 4014

② DIN 5480

③ DIN 332-D

④ DIN 332

⑤ Feather key/keyway DIN 6885

⑥ ISO 4762

⑦ Without locating shoulder +1 mm

⑧ Use bores only for foot-mounted design

K.Z.69 gearbox in a housing flange design

KZ030K4, KAZ030K4, KAZS030K4, KAZT030K4

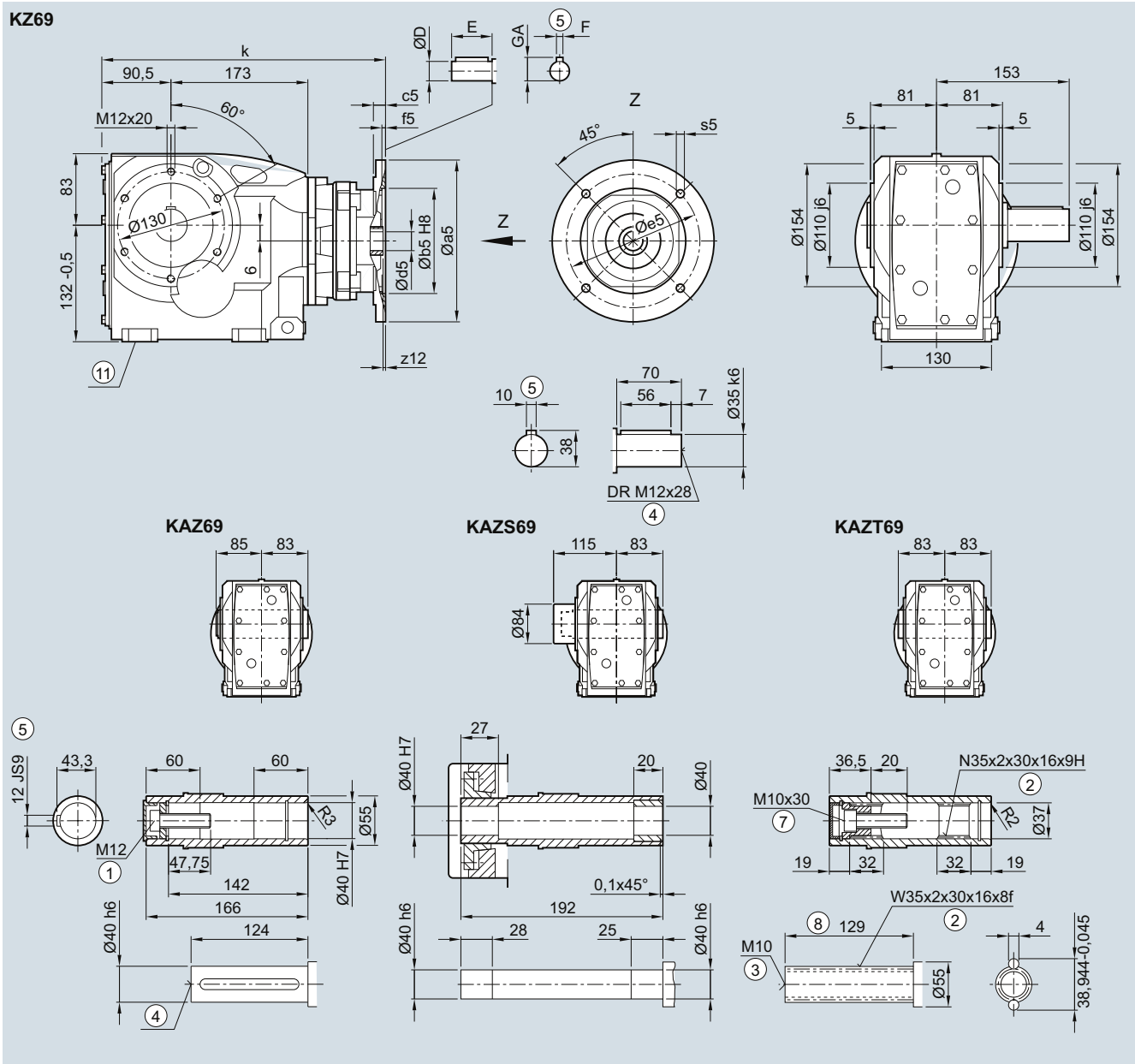

Adapter	a5	b5	c5	f5	e5	s5	z12	d5/D	E	F	GA	k
63	140	95	12	4.5	115	M8	2.5	11	23	4	12.5	331.5
71	160	110	12	4.5	130	M8	2.5	14	30	5	16.0	331.5
80	200	130	15	4.5	165	M10	4.0	19	40	6	12.5	359.5
90	200	130	15	4.5	165	M10	4.0	24	50	8	27.0	359.5
100	250	180	14	5.0	215	M12x21	7.5	28	60	8	31.0	414.0
112	250	180	14	5.0	215	M12x21	7.5	28	60	8	31.0	414.0
132	300	230	12	6.0	265	M12x20	3.0	38	80	10	41.0	431.5

① ISO 4014 ② DIN 5480 ③ DIN 332-D ④ DIN 332 ⑤ Feather key/keyway DIN 6885
 ⑦ ISO 4762 ⑧ Without locating shoulder +1 mm ⑨ Use bores only for foot-mounted design

SIMOGEAR Gearboxes

Bevel gearbox with adapter K4

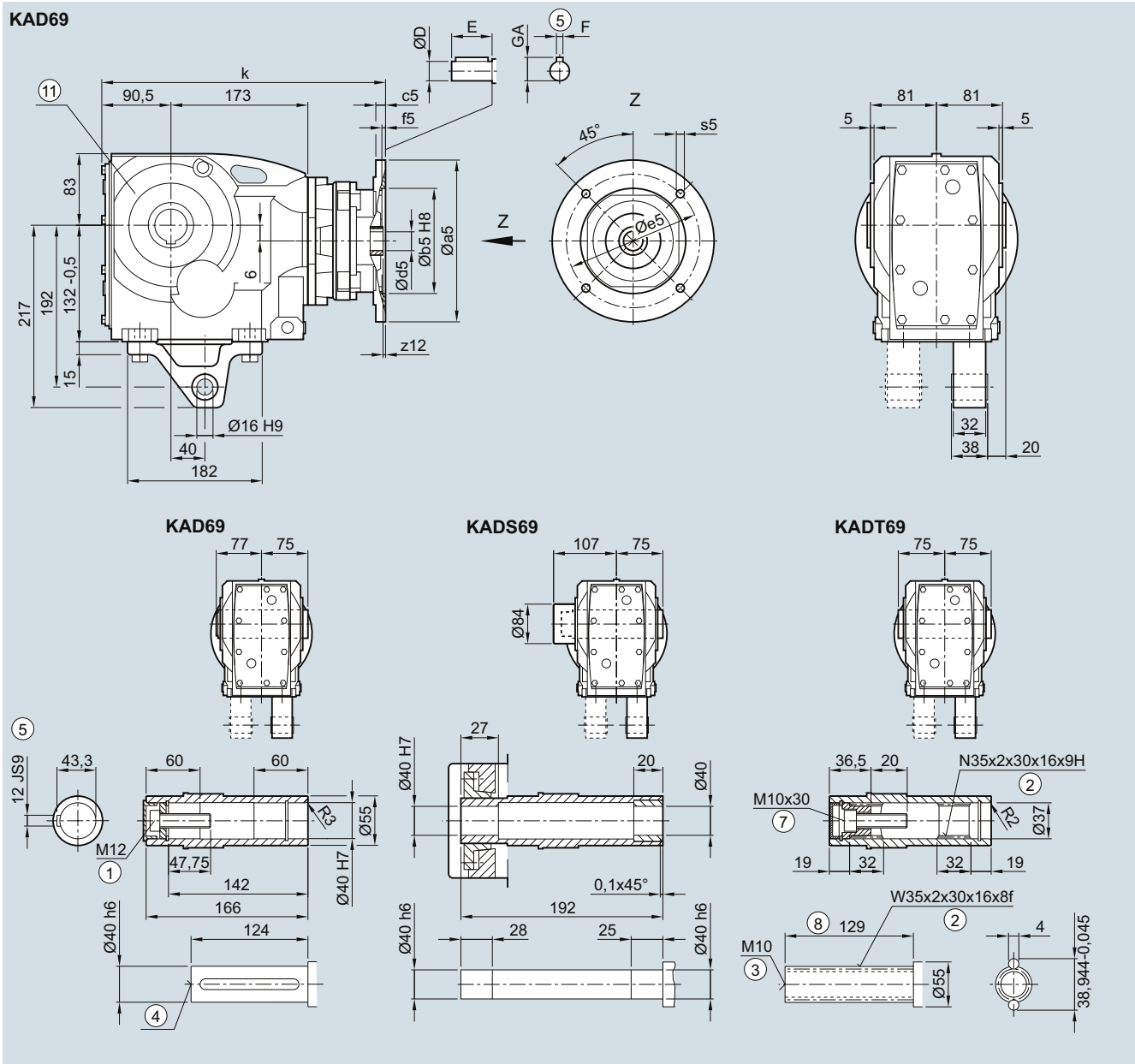
Dimensions**KAD.69 gearbox in a shaft-mounted design****KAD030K4, KADS030K4, KADT030K4**

Adapter	a5	b5	c5	f5	e5	s5	z12	d5/D	E	F	GA	k
63	140	95	12	4.5	115	M8	2.5	11	23	4	12.5	331.5
71	160	110	12	4.5	130	M8	2.5	14	30	5	16.0	331.5
80	200	130	15	4.5	165	M10	4.0	19	40	6	12.5	359.5
90	200	130	15	4.5	165	M10	4.0	24	50	8	27.0	359.5
100	250	180	14	5.0	215	M12x21	7.5	28	60	8	31.0	414.0
112	250	180	14	5.0	215	M12x21	7.5	28	60	8	31.0	414.0
132	300	230	12	6.0	265	M12x20	3.0	38	80	10	41.0	431.5

① ISO 4014

② DIN 5480

③ DIN 332-D

④ DIN 332

⑤ Feather key/keyway DIN 6885

⑦ ISO 4762

⑧ Without locating shoulder +1 mm

⑨ Use bores only for housing flange design

K.79 gearbox in a foot-mounted design

K030K4, KA030K4, KAS030K4, KAT030K4

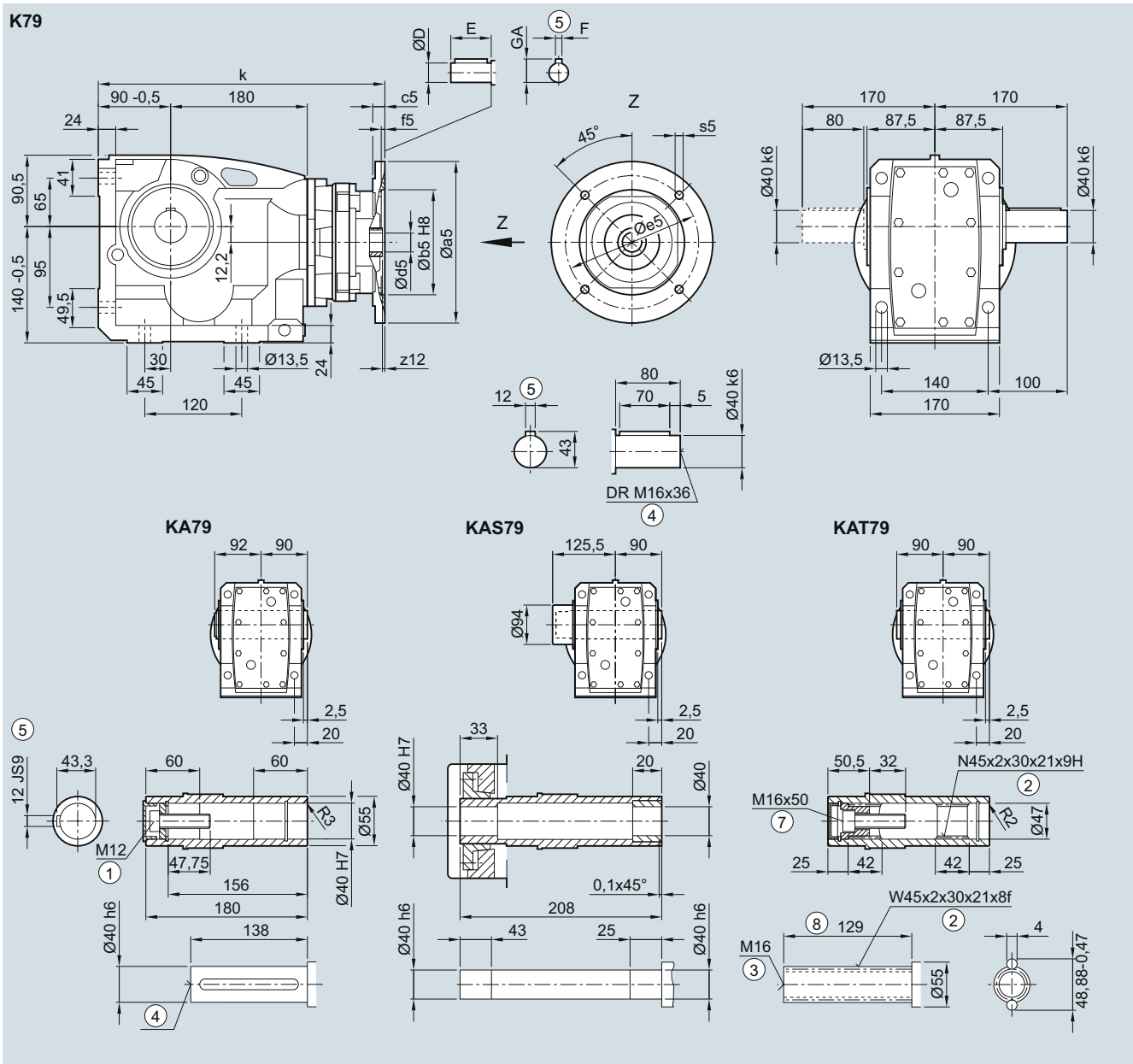

5

Adapter	a5	b5	c5	f5	e5	s5	z12	d5/D	E	F	GA	k
63	140	95	12	4.5	115.0	M8	2.5	11	23	4	12.5	338.0
71	160	110	12	4.5	130.0	M8	2.5	14	30	5	16.0	338.0
80	200	130	15	4.5	165.0	M10	4.0	19	40	6	12.5	366.0
90	200	130	15	4.5	165.0	M10	4.0	24	50	8	27.0	366.0
100	250	180	14	5	215.0	M12x21	7.5	28	60	8	31.0	420.5
112	250	180	14	5	215.0	M12x21	7.5	28	60	8	31.0	420.5
132	300	230	12	6	265.0	M12x20	3.0	38	80	10	41.0	438.0

① ISO 4014 ② DIN 5480 ③ DIN 332-D ④ DIN 332 ⑤ Feather key/keyway DIN 6885 ⑦ ISO 4762 ⑧ Without locating shoulder +1 mm

SIMOGEAR Gearboxes

Bevel gearbox with adapter K4

Dimensions

K.F.79 gearbox in a flange-mounted design

KF030K4, KAF030K4, KAFS030K4, KAFT030K4

KF79

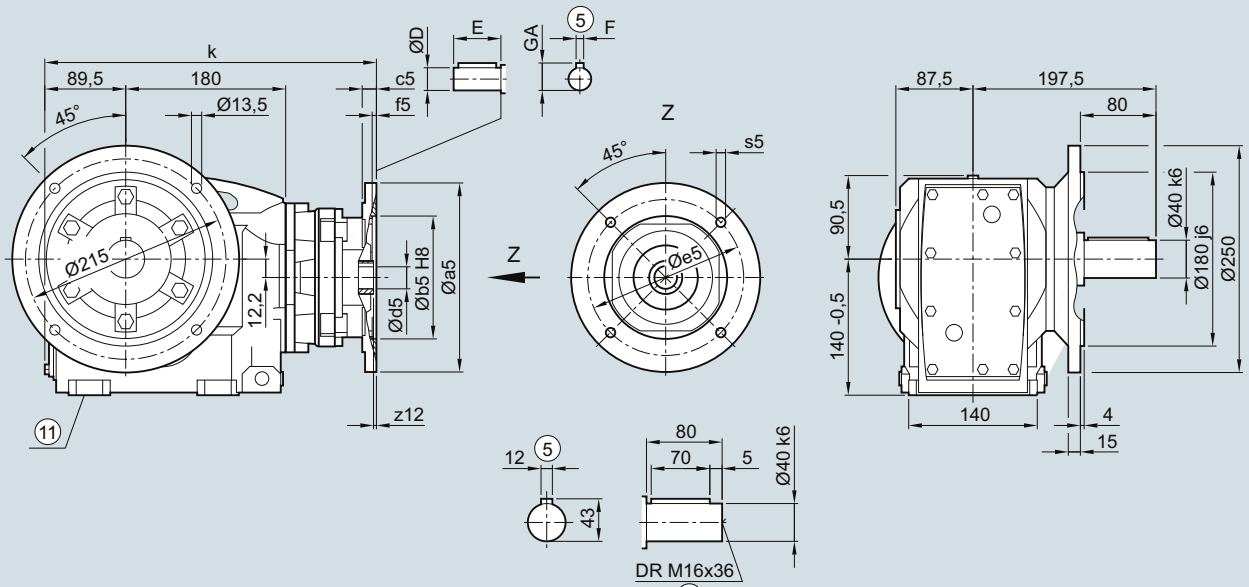

KAF79

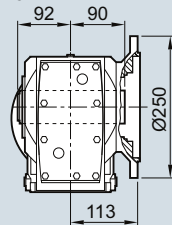

KAFS79

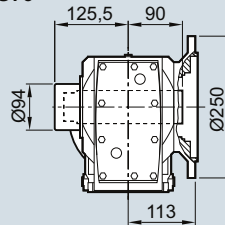

KAFT79

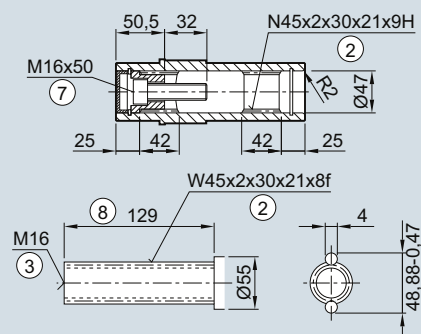
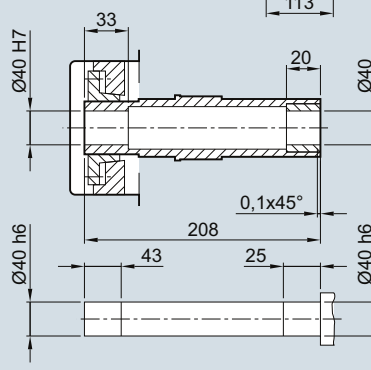
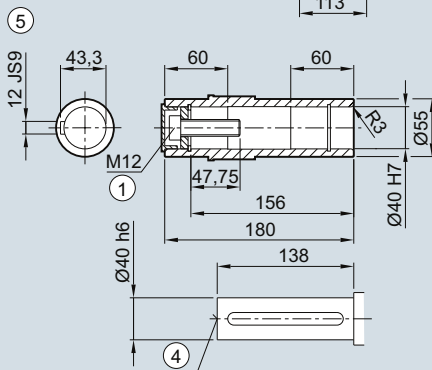
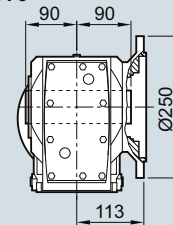

Adapter	a5	b5	c5	f5	e5	s5	z12	d5/D	E	F	GA	k
63	140	95	12	4.5	115	M8	2.5	11	23	4	12.5	337.5
71	160	110	12	4.5	130	M8	2.5	14	30	5	16.0	337.5
80	200	130	15	4.5	165	M10	4.0	19	40	6	12.5	365.5
90	200	130	15	4.5	165	M10	4.0	24	50	8	27.0	365.5
100	250	180	14	5.0	215	M12x21	7.5	28	60	8	31.0	420.0
112	250	180	14	5.0	215	M12x21	7.5	28	60	8	31.0	420.0
132	300	230	12	6.0	265	M12x20	3.0	38	80	10	41.0	437.5

① ISO 4014

② DIN 5480

③ DIN 332-D

④ DIN 332

⑤ Feather key/keyway DIN 6885

⑥ ISO 4762

⑧ Without locating shoulder +1 mm

⑨ Use bores only for foot-mounted design

K.Z.79 gearbox in a housing flange design

KZ030K4, KAZ030K4, KAZS030K4, KAZT030K4

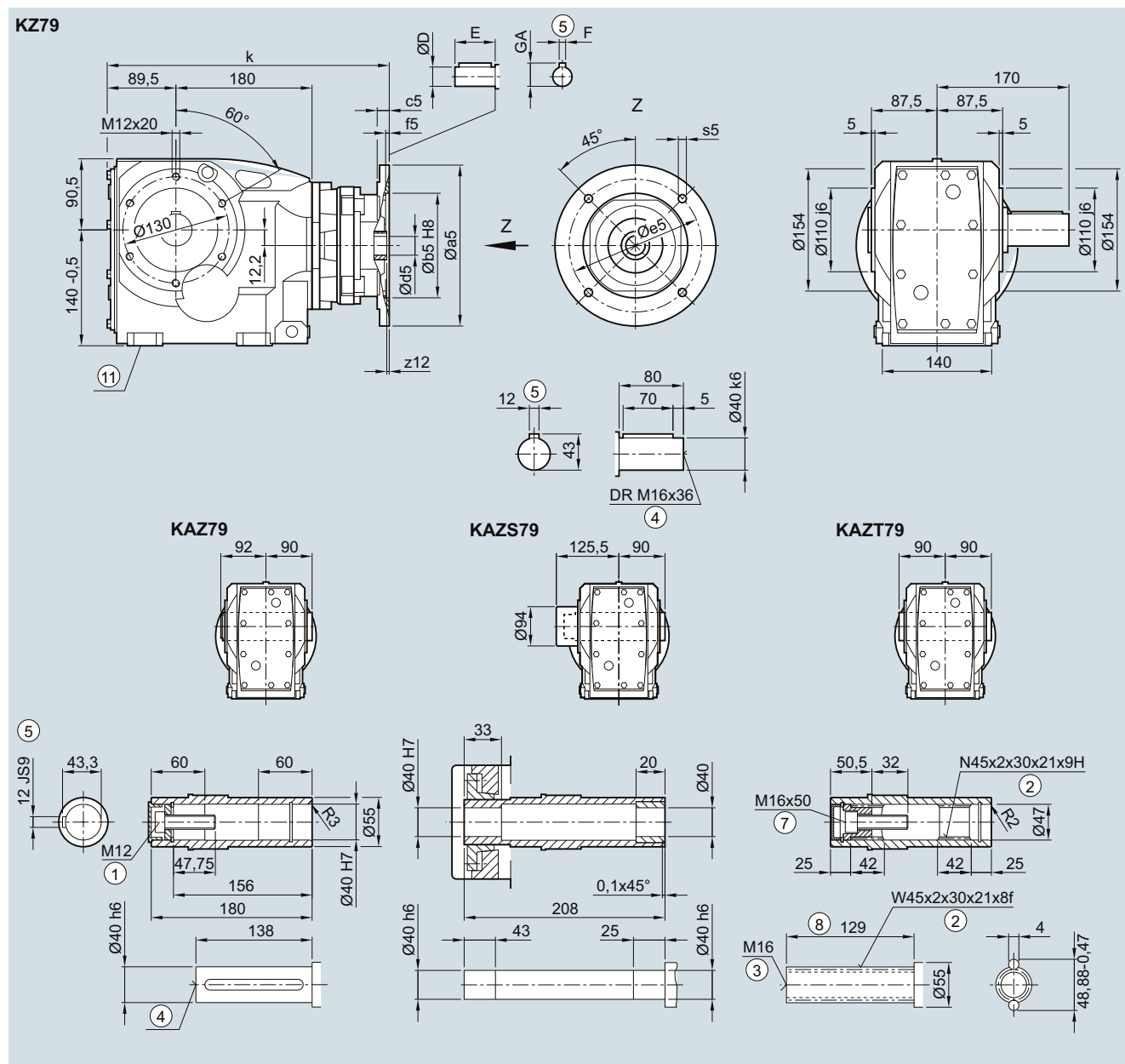

Adapter	a5	b5	c5	f5	e5	s5	z12	d5/D	E	F	GA	k
63	140	95	12	4.5	115	M8	2.5	11	23	4	12.5	337.5
71	160	110	12	4.5	130	M8	2.5	14	30	5	16.0	337.5
80	200	130	15	4.5	165	M10	4.0	19	40	6	12.5	365.5
90	200	130	15	4.5	165	M10	4.0	24	50	8	27.0	365.5
100	250	180	14	5.0	215	M12x21	7.5	28	60	8	31.0	420.0
112	250	180	14	5.0	215	M12x21	7.5	28	60	8	31.0	420.0
132	300	230	12	6.0	265	M12x20	3.0	38	80	10	41.0	437.5

① ISO 4014

② DIN 5480

③ DIN 332-D

④ DIN 332

⑤ Feather key/keyway DIN 6885

⑥ ISO 4762

⑦ Without locating shoulder +1 mm

⑧ Use bores only for foot-mounted design

SIMOGEAR Gearboxes

Bevel gearbox with adapter K4

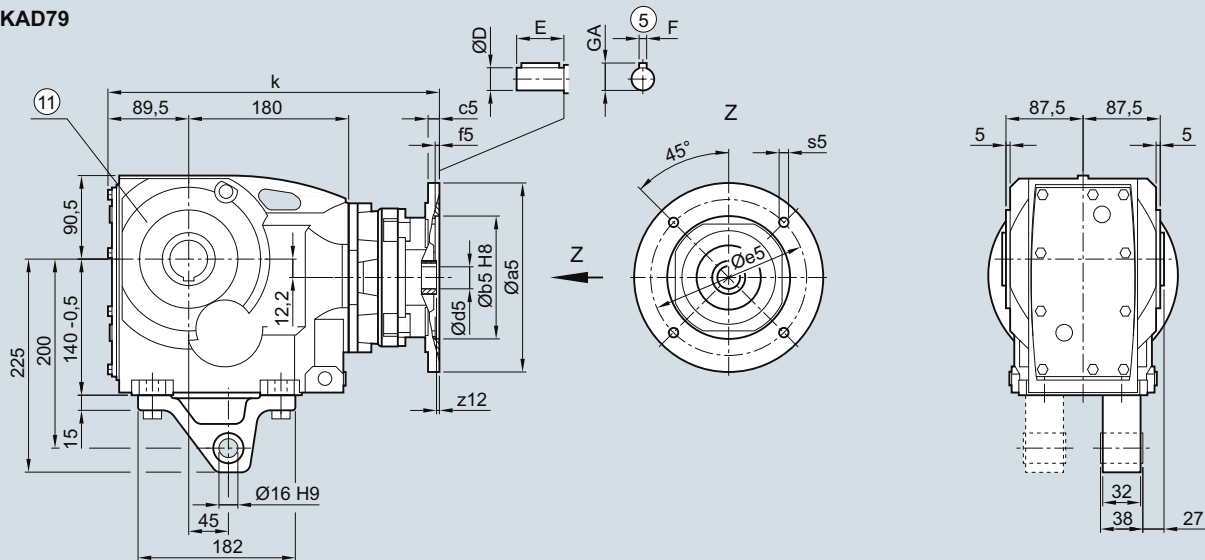
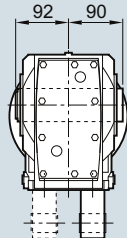
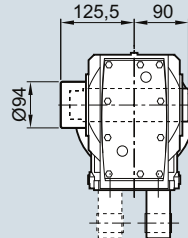
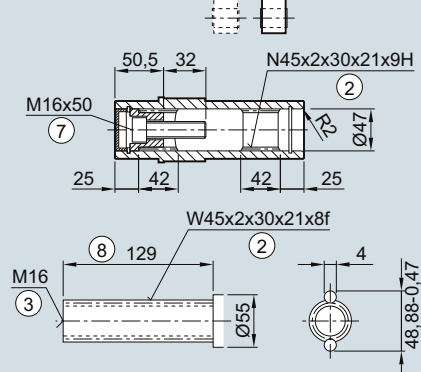
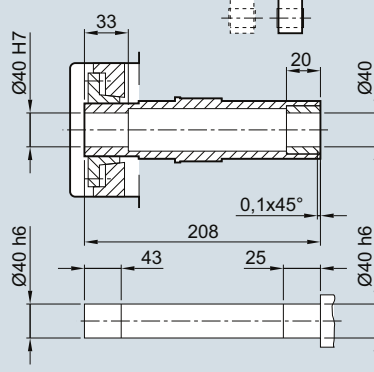
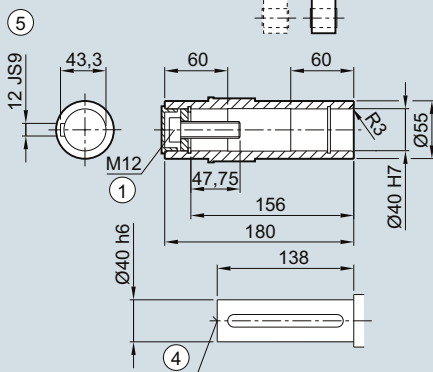
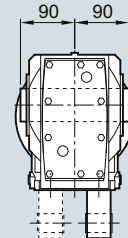
Dimensions**KAD.79 gearbox in a shaft-mounted design****KAD030K4, KADS030K4, KADT030K4****KAD79****KAD79****KADS79****KADT79**

Adapter	a5	b5	c5	f5	e5	s5	z12	d5/D	E	F	GA	k
63	140	95	12	4.5	115	M8	2.5	11	23	4	12.5	337.5
71	160	110	12	4.5	130	M8	2.5	14	30	5	16.0	337.5
80	200	130	15	4.5	165	M10	4.0	19	40	6	12.5	365.5
90	200	130	15	4.5	165	M10	4.0	24	50	8	27.0	365.5
100	250	180	14	5.0	215	M12x21	7.5	28	60	8	31.0	420.0
112	250	180	14	5.0	215	M12x21	7.5	28	60	8	31.0	420.0
132	300	230	12	6.0	265	M12x20	3.0	38	80	10	41.0	437.5

① ISO 4014
⑦ ISO 4762

② DIN 5480
⑧ Without locating shoulder +1 mm

③ DIN 332-D

④ DIN 332

⑤ Feather key/keyway DIN 6885

⑨ Use bores only for housing flange design

K.89 gearbox in a foot-mounted design

K030K4, KA030K4, KAS030K4, KAT030K4

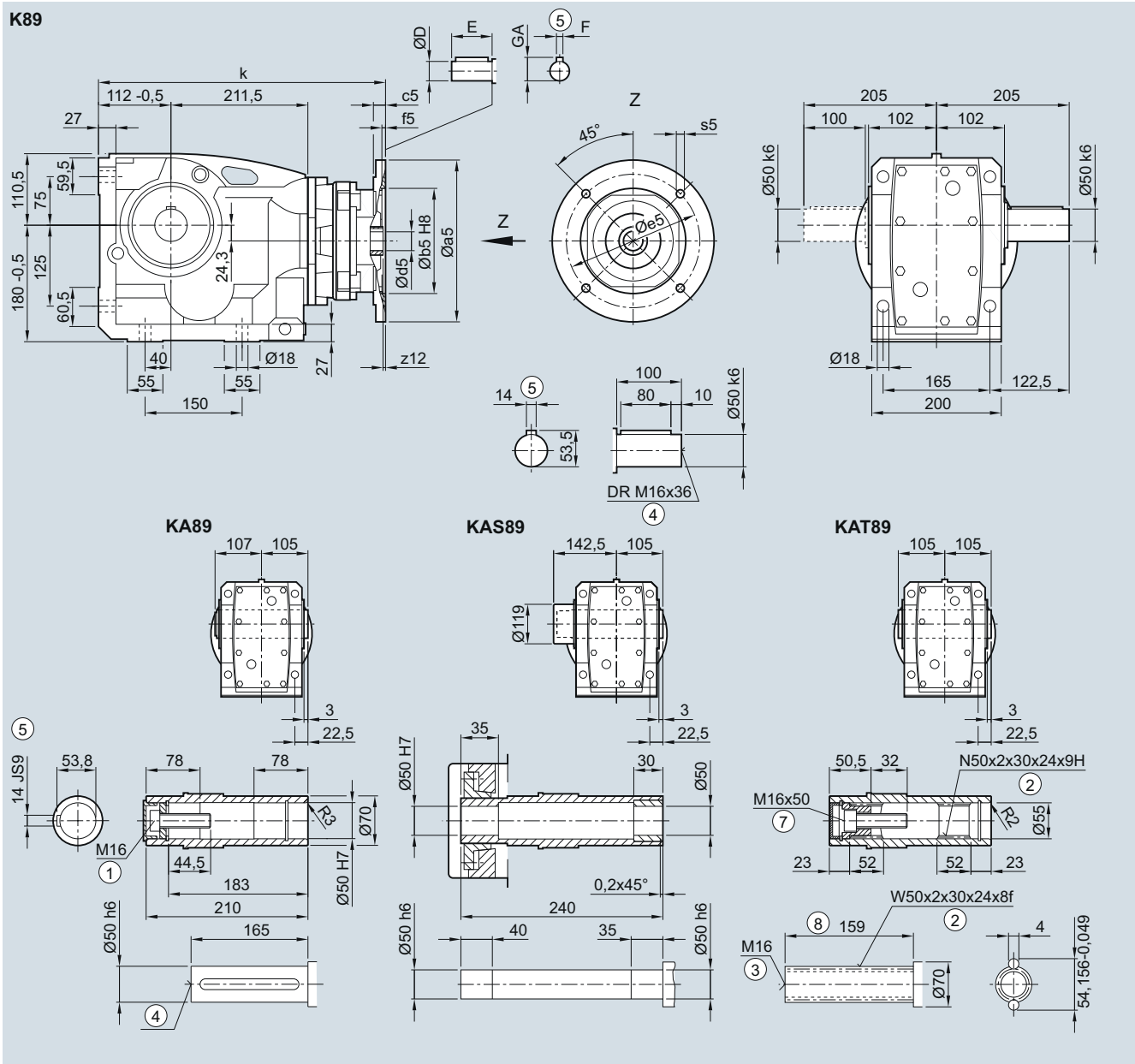

5

Adapter	a5	b5	c5	f5	e5	s5	z12	d5/D	E	F	GA	k
71	160	110	12	4.5	130.0	M8	2.5	14	30	5	16.0	389.5
80	200	130	15	4.5	165.0	M10	4.0	19	40	6	12.5	413.5
90	200	130	15	4.5	165.0	M10	4.0	24	50	8	27.0	413.5
100	250	180	14	5.0	215.0	M12x21	7.5	28	60	8	31.0	468.0
112	250	180	14	5.0	215.0	M12x21	7.5	28	60	8	31.0	468.0
132	300	230	12	6.0	265.0	M12x20	3.0	38	80	10	41.0	485.5
160	350	250	15	6.0	300.0	M16x25	3.0	42	110	12	45.0	515.5

① ISO 4014 ② DIN 5480 ③ DIN 332-D ④ DIN 332 ⑤ Feather key/keyway DIN 6885 ⑦ ISO 4762 ⑥ Without locating shoulder +1 mm

SIMOGEAR Gearboxes

Bevel gearbox with adapter K4

Dimensions

K.F.89 gearbox in a flange-mounted design

KF030K4, KAF030K4, KAFS030K4, KAFT030K4

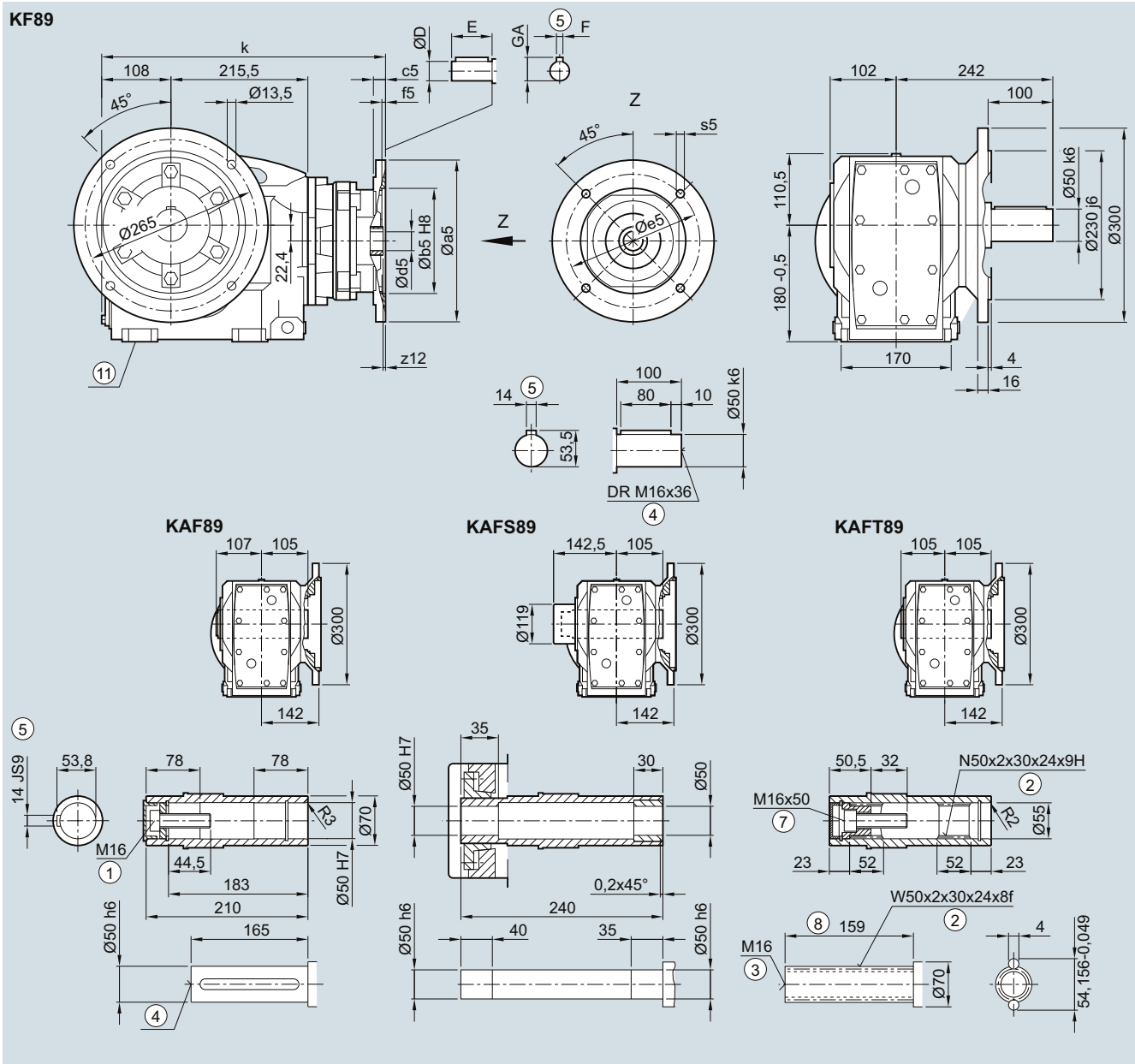

Adapter	a5	b5	c5	f5	e5	s5	z12	d5/D	E	F	GA	k
71	160	110	12	4.5	130	M8	2.5	14	30	5	16.0	389.5
80	200	130	15	4.5	165	M10	4.0	19	40	6	12.5	413.5
90	200	130	15	4.5	165	M10	4.0	24	50	8	27.0	413.5
100	250	180	14	5.0	215	M12x21	7.5	28	60	8	31.0	468.0
112	250	180	14	5.0	215	M12x21	7.5	28	60	8	31.0	468.0
132	300	230	12	6.0	265	M12x20	3.0	38	80	10	41.0	485.5
160	350	250	15	6.0	300	M16x25	3.0	42	110	12	45.0	515.5

① ISO 4014

② DIN 5480

③ DIN 332-D

④ DIN 332

⑤ Feather key/keyway DIN 6885

⑥ ISO 4762

⑦ Without locating shoulder +1 mm

⑧ Use bores only for foot-mounted design

K.Z.89 gearbox in a housing flange design

KZ030K4, KAZ030K4, KAZS030K4, KAZT030K4

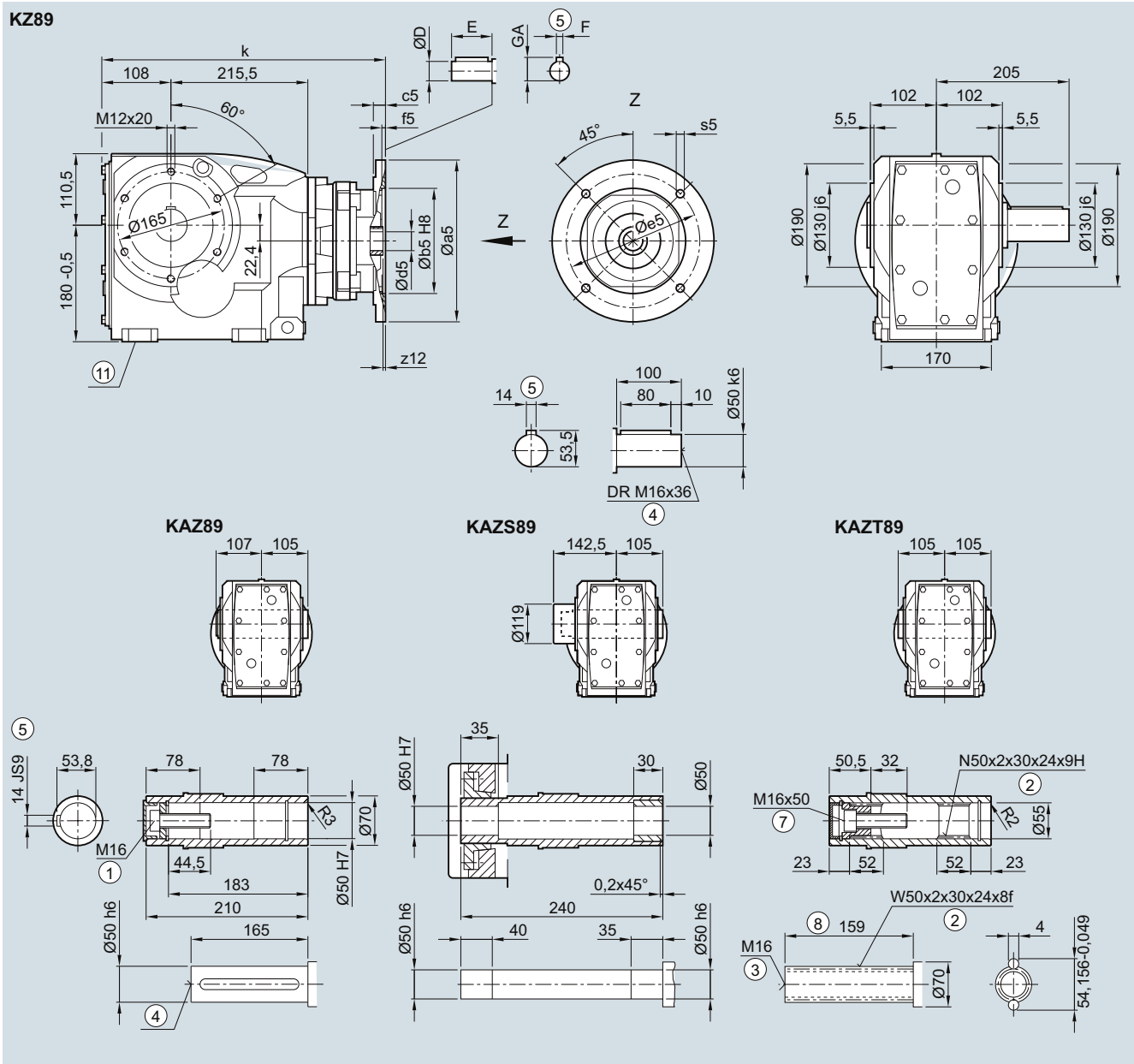

Adapter	a5	b5	c5	f5	e5	s5	z12	d5/D	E	F	GA	k
71	160	110	12	4.5	130	M8	2.5	14	30	5	16.0	389.5
80	200	130	15	4.5	165	M10	4.0	19	40	6	12.5	413.5
90	200	130	15	4.5	165	M10	4.0	24	50	8	27.0	413.5
100	250	180	14	5.0	215	M12x21	7.5	28	60	8	31.0	468.0
112	250	180	14	5.0	215	M12x21	7.5	28	60	8	31.0	468.0
132	300	230	12	6.0	265	M12x20	3.0	38	80	10	41.0	485.5
160	350	250	15	6.0	300	M16x25	3.0	42	110	12	45.0	515.5

① ISO 4014 ② DIN 5480 ③ DIN 332-D ④ DIN 332 ⑤ Feather key/keyway DIN 6885
 ⑥ ISO 4762 ⑦ Without locating shoulder +1 mm ⑧ Use bores only for foot-mounted design

SIMOGEAR Gearboxes

Bevel gearbox with adapter K4

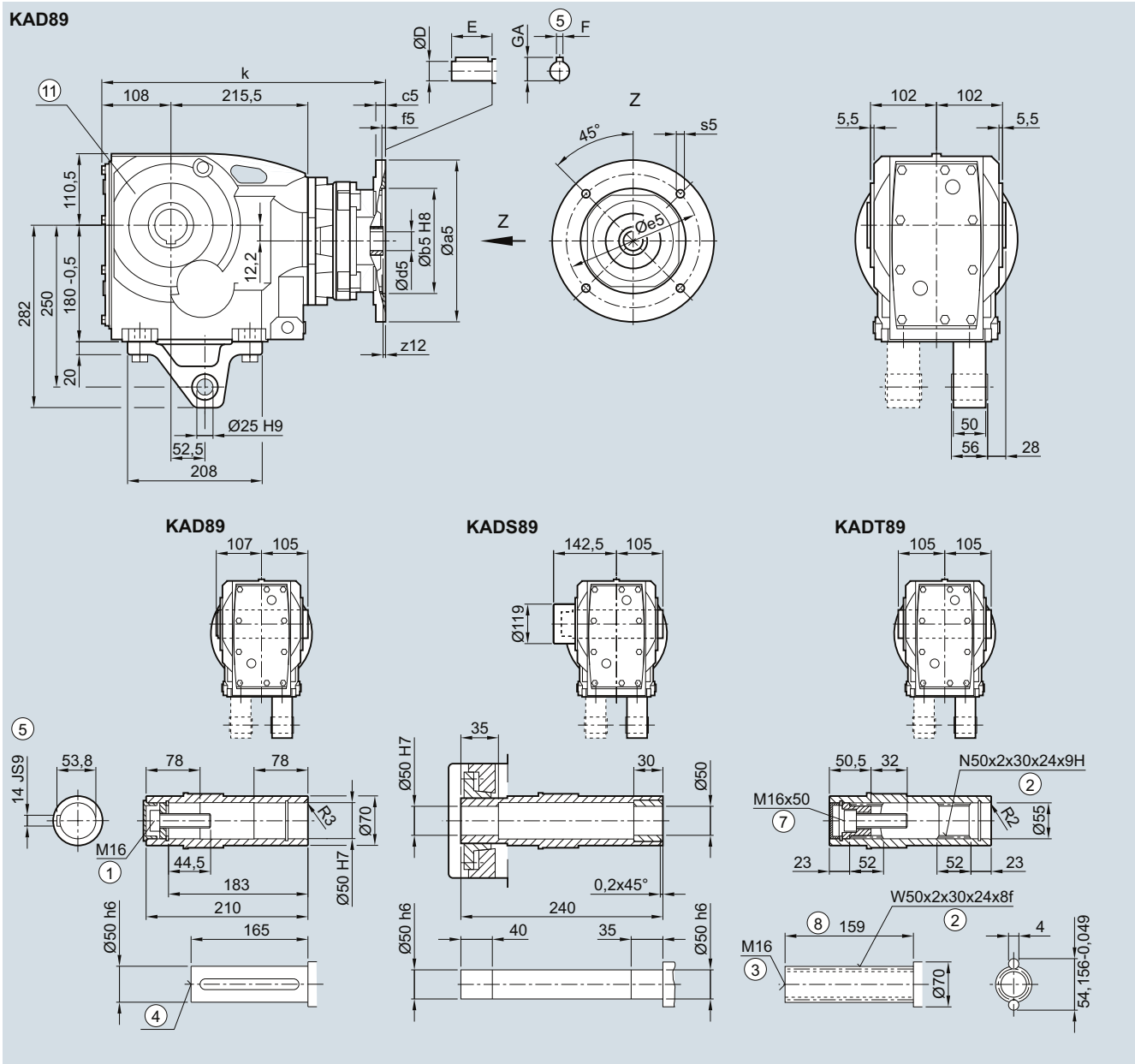
Dimensions**KAD.89 gearbox in a shaft-mounted design****KAD030K4, KADS030K4, KADT030K4**

Adapter	a5	b5	c5	f5	e5	s5	z12	d5/D	E	F	GA	k
71	160	110	12	4.5	130	M8	2.5	14	30	5	16.0	389.5
80	200	130	15	4.5	165	M10	4.0	19	40	6	12.5	413.5
90	200	130	15	4.5	165	M10	4.0	24	50	8	27.0	413.5
100	250	180	14	5.0	215	M12x21	7.5	28	60	8	31.0	468.0
112	250	180	14	5.0	215	M12x21	7.5	28	60	8	31.0	468.0
132	300	230	12	6.0	265	M12x20	3.0	38	80	10	41.0	485.5
160	350	250	15	6.0	300	M16x25	3.0	42	110	12	45.0	515.5

① ISO 4014

② DIN 5480

③ DIN 332-D

④ DIN 332

⑤ Feather key/keyway DIN 6885

⑦ ISO 4762

⑧ Without locating shoulder +1 mm

⑨ Use bores only for housing flange design

K.109 gearbox in a foot-mounted design

K030K4, KA030K4, KAS030K4, KAT030K4

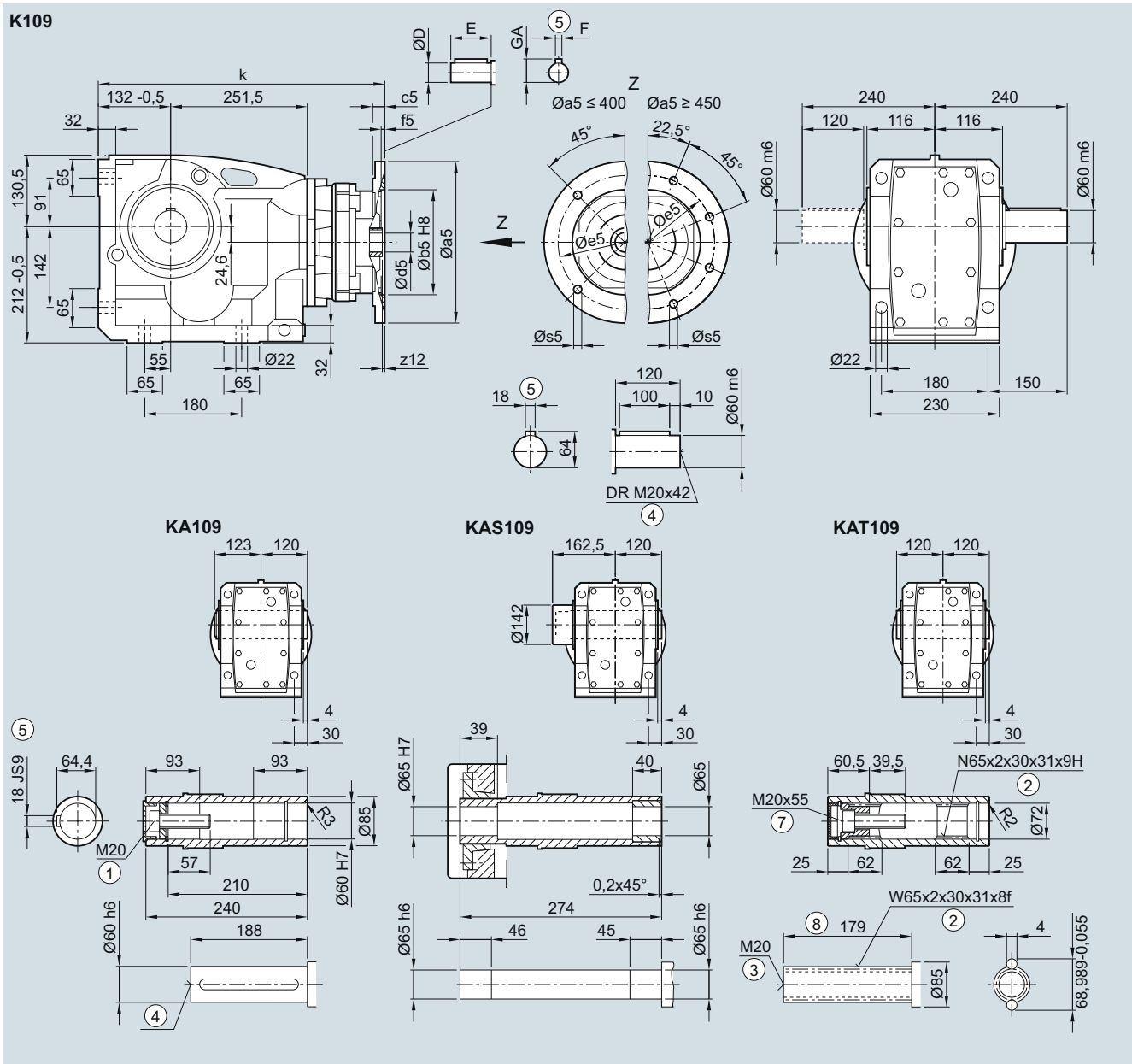

Adapter	a5	b5	c5	f5	e5	s5	z12	d5/D	E	F	GA	k
80	200	130	15	4.5	165	M10	4.0	19	40	6	12.5	460.5
90	200	130	15	4.5	165	M10	4.0	24	50	8	27.0	460.5
100	250	180	14	5.0	215	M12x21	7.5	28	60	8	31.0	511.0
112	250	180	14	5.0	215	M12x21	7.5	28	60	8	31.0	511.0
132	300	230	12	6.0	265	M12x20	3.0	38	80	10	41.0	528.5
160	350	250	15	6.0	300	M16x25	3.0	42	110	12	45.0	558.5
180	350	250	15	6.0	300	M16x25	3.0	48	110	14	51.5	558.5

① ISO 4014 ② DIN 5480 ③ DIN 332-D ④ DIN 332 ⑤ Feather key/keyway DIN 6885 ⑦ ISO 4762 ⑧ Without locating shoulder +1 mm

SIMOGEAR Gearboxes

Bevel gearbox with adapter K4

Dimensions

K.F.109 gearbox in a flange-mounted design

KF030K4, KAF030K4, KAFS030K4, KAFT030K4

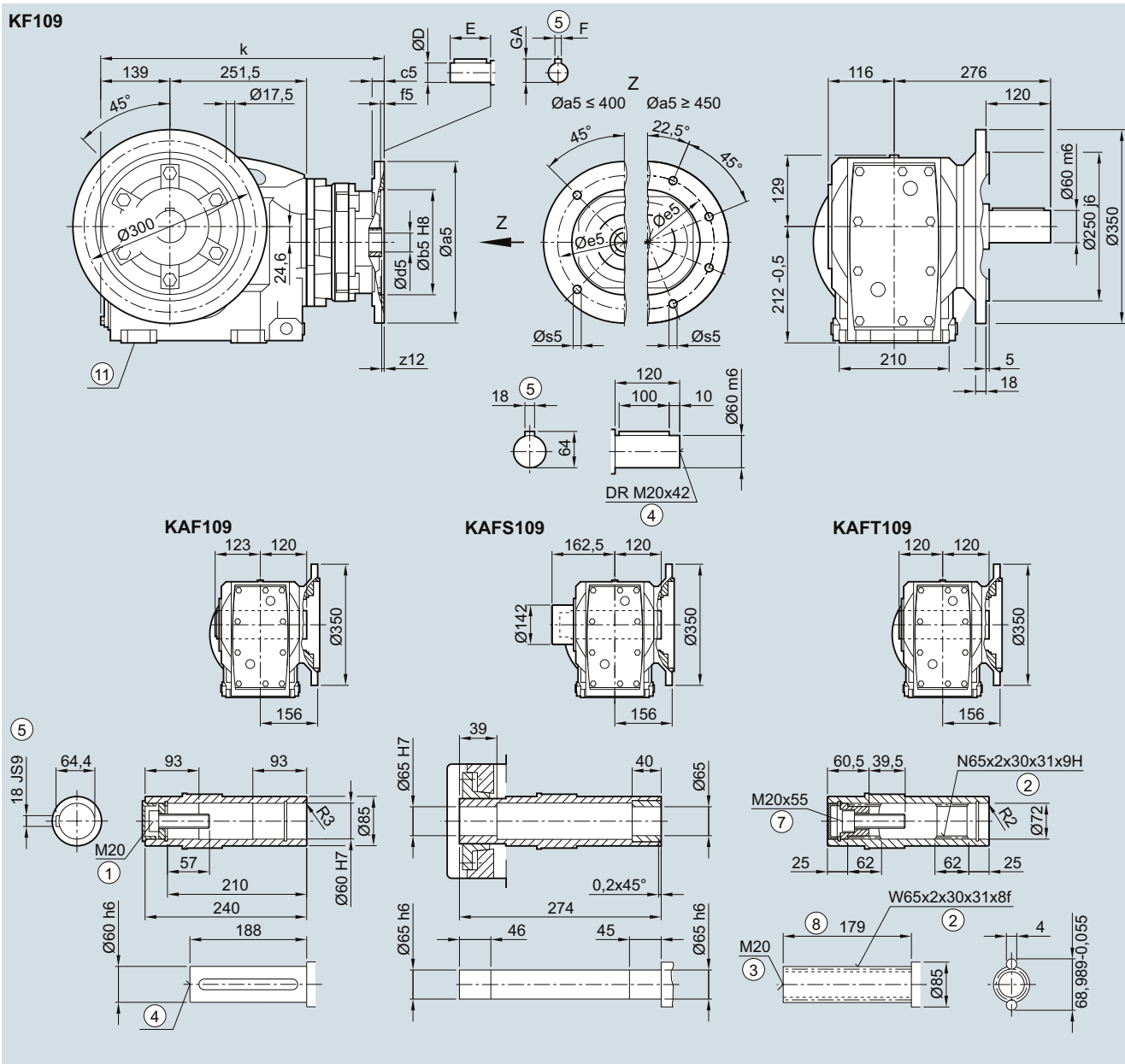

Adapter	a5	b5	c5	f5	e5	s5	z12	d5/D	E	F	GA	k
80	200	130	15	4.5	165	M10	4.0	19	40	6	12.5	467.5
90	200	130	15	4.5	165	M10	4.0	24	50	8	27.0	467.5
100	250	180	14	5.0	215	M12x21	7.5	28	60	8	31.0	518.0
112	250	180	14	5.0	215	M12x21	7.5	28	60	8	31.0	518.0
132	300	230	12	6.0	265	M12x20	3.0	38	80	10	41.0	535.5
160	350	250	15	6.0	300	M16x25	3.0	42	110	12	45.0	565.5
180	350	250	15	6.0	300	M16x25	3.0	48	110	14	51.5	565.5

① ISO 4014 ② DIN 5480 ③ DIN 332-D ④ DIN 332 ⑤ Feather key/keyway DIN 6885
 ⑦ ISO 4762 ⑧ Without locating shoulder +1 mm ⑨ Use bores only for foot-mounted design

5

K.Z.109 gearbox in a housing flange design

KZ030K4, KAZ030K4, KAZS030K4, KAZT030K4

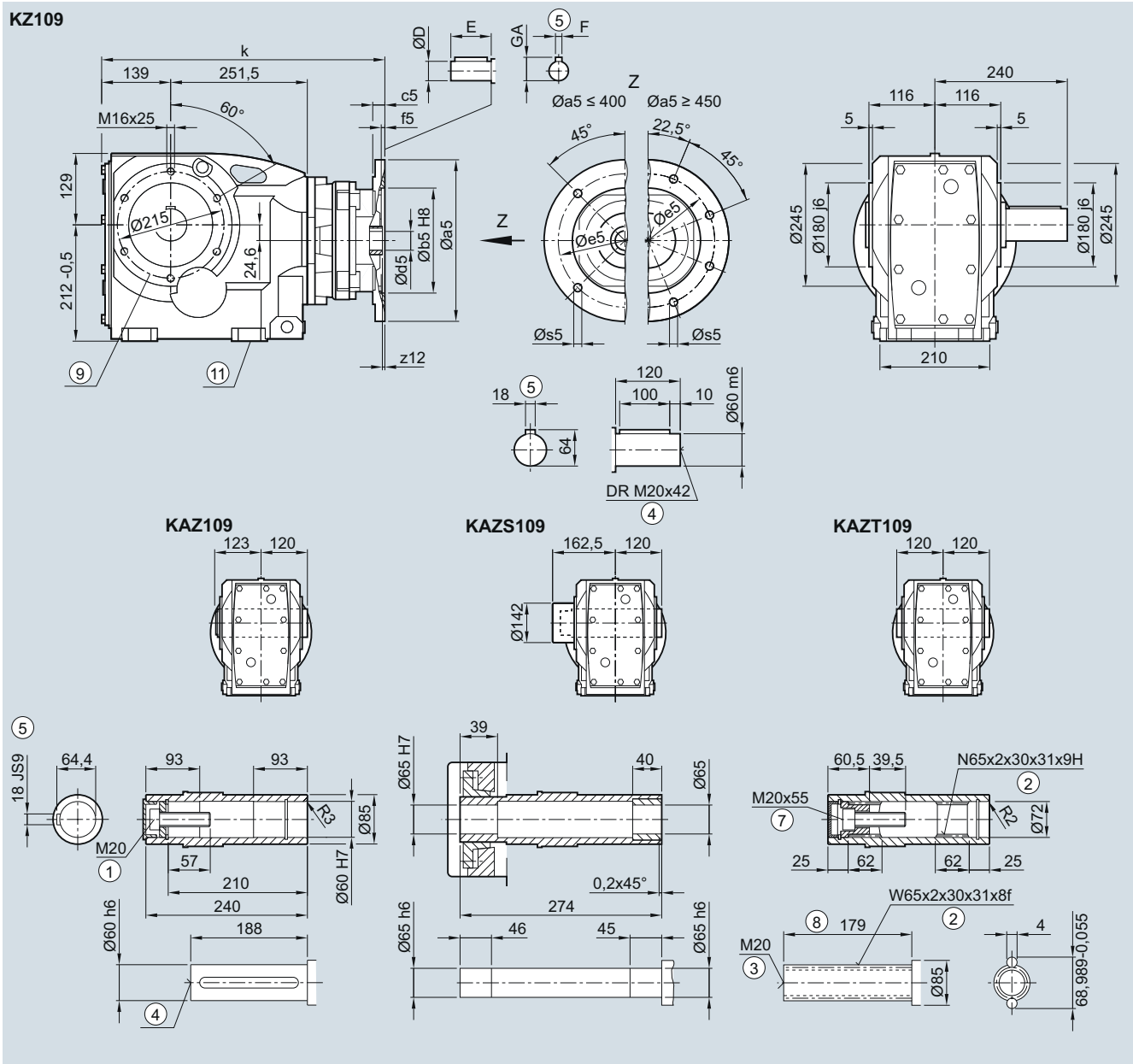

Adapter	a5	b5	c5	f5	e5	s5	z12	d5/D	E	F	GA	k
80	200	130	15	4.5	165	M10	4.0	19	40	6	12.5	467.5
90	200	130	15	4.5	165	M10	4.0	24	50	8	27.0	467.5
100	250	180	14	5.0	215	M12x21	7.5	28	60	8	31.0	518.0
112	250	180	14	5.0	215	M12x21	7.5	28	60	8	31.0	518.0
132	300	230	12	6.0	265	M12x20	3.0	38	80	10	41.0	535.5
160	350	250	15	6.0	300	M16x25	3.0	42	110	12	45.0	565.5
180	350	250	15	6.0	300	M16x25	3.0	48	110	14	51.5	565.5

① ISO 4014 ② DIN 5480 ③ DIN 332-D ④ DIN 332 ⑤ Feather key/keyway DIN 6885
 ⑦ ISO 4762 ⑧ Without locating shoulder +1 mm ⑨ For pin holes, see 4/131 ⑩ Use bores only for foot-mounted design

SIMOGEAR Gearboxes

Bevel gearbox with adapter K4

Dimensions

KAD.109 gearbox in a shaft-mounted design

KAD030K4, KADS030K4, KADT030K4

KAD109

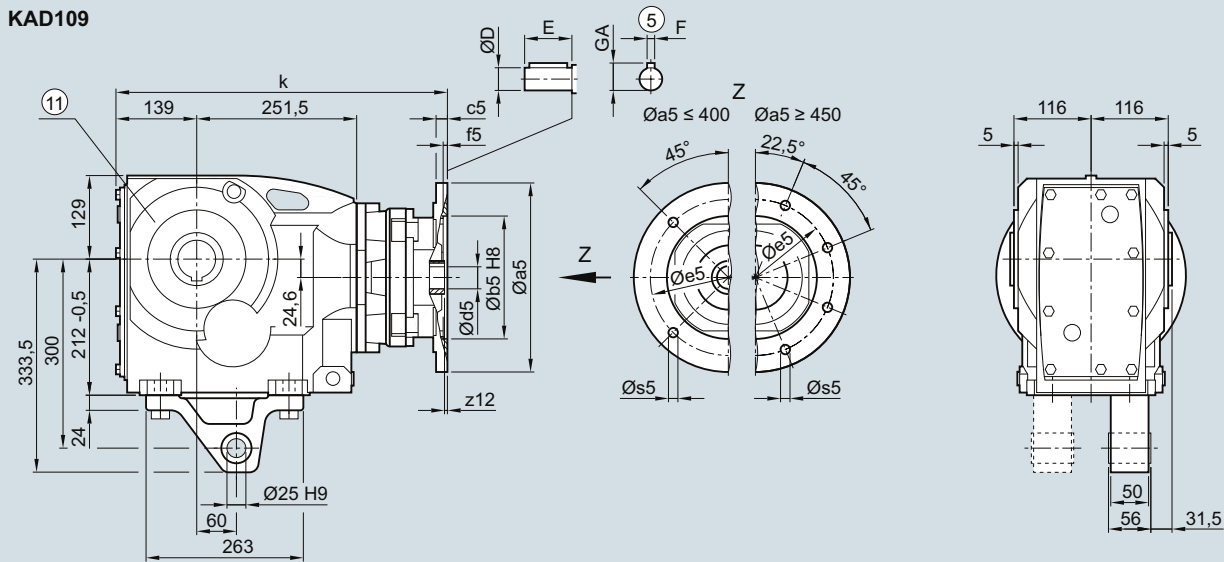

KAD109

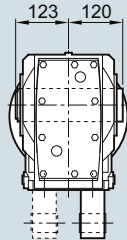

KADS109

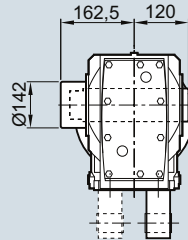

KADT109

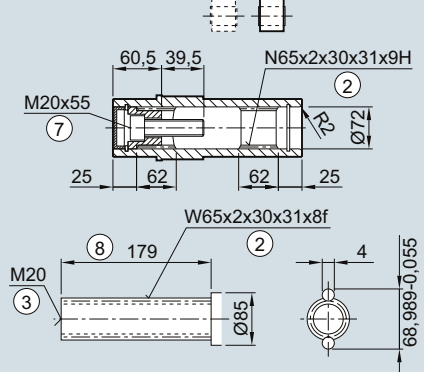
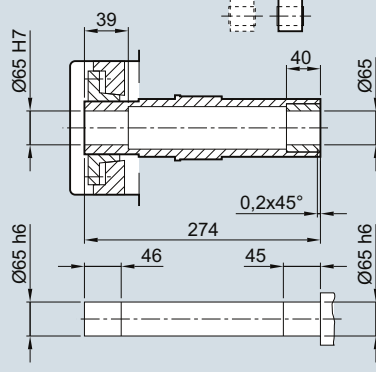
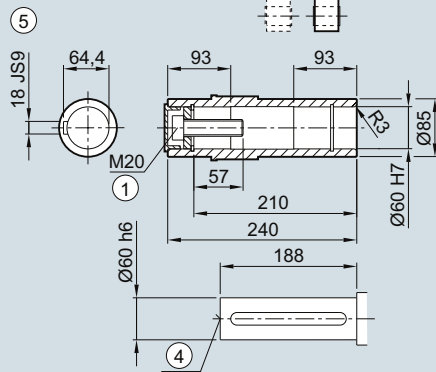
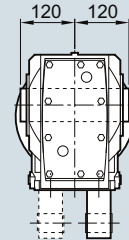

Adapter	a5	b5	c5	f5	e5	s5	z12	d5/D	E	F	GA	k
80	200	130	15	4.5	165	M10	4.0	19	40	6	12.5	467.5
90	200	130	15	4.5	165	M10	4.0	24	50	8	27.0	467.5
100	250	180	14	5.0	215	M12x21	7.5	28	60	8	31.0	518.0
112	250	180	14	5.0	215	M12x21	7.5	28	60	8	31.0	518.0
132	300	230	12	6.0	265	M12x20	3.0	38	80	10	41.0	535.5
160	350	250	15	6.0	300	M16x25	3.0	42	110	12	45.0	565.5
180	350	250	15	6.0	300	M16x25	3.0	48	110	14	51.5	565.5

① ISO 4014
⑦ ISO 4762

② DIN 5480
⑧ Without locating shoulder +1 mm

③ DIN 332-D

④ DIN 332

⑤ Feather key/keyway DIN 6885

⑨ Use bores only for housing flange design

K.129 gearbox in a foot-mounted design

K030K4, KA030K4, KAS030K4, KAT030K4

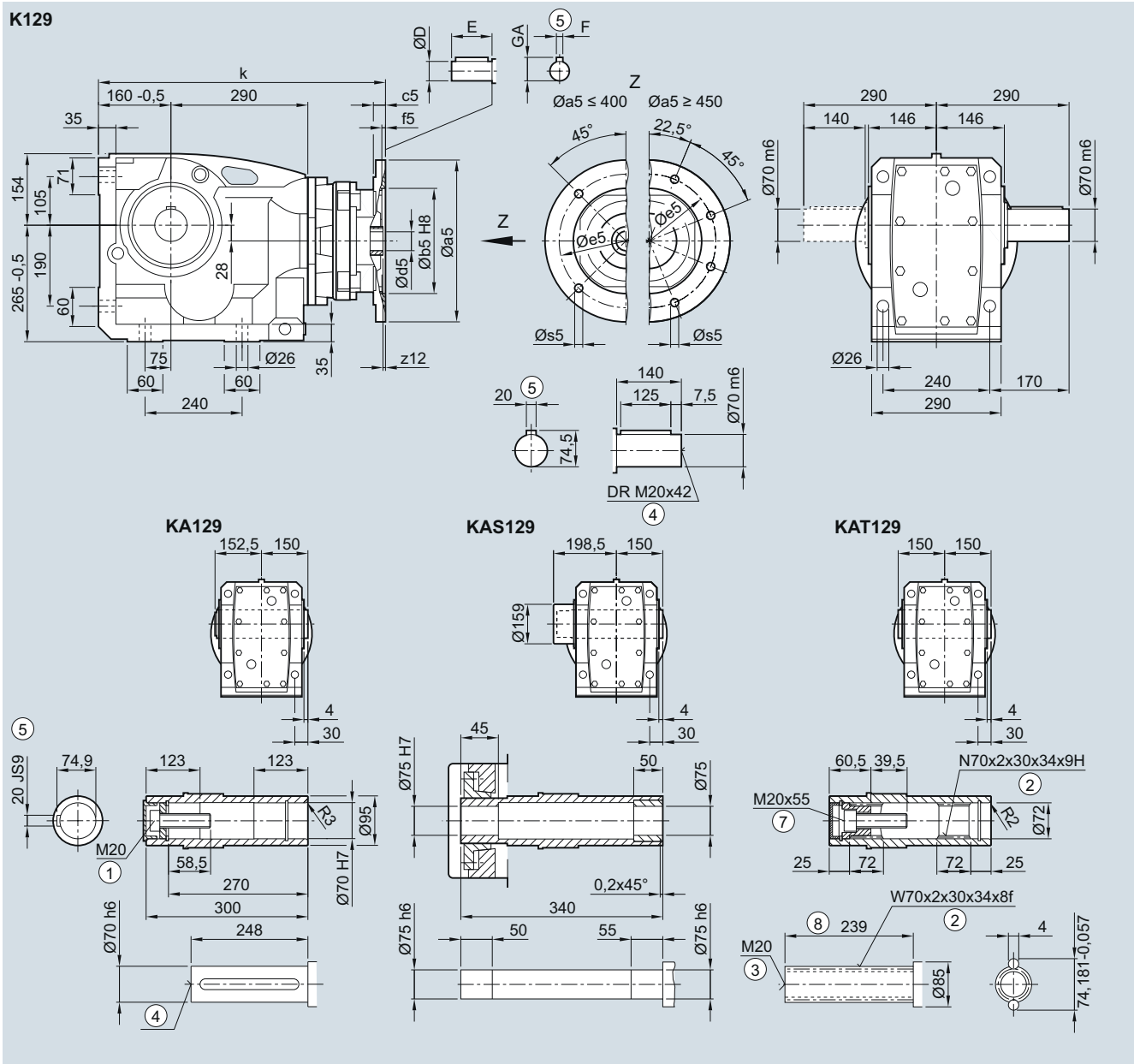

5

Adapter	a5	b5	c5	f5	e5	s5	z12	d5/D	E	F	GA	k
90	200	130	15	4.5	165	M10	4.0	24	50	8	27.0	520.0
100	250	180	14	5.0	215	M12x21	7.5	28	60	8	31.0	568.5
112	250	180	14	5.0	215	M12x21	7.5	28	60	8	31.0	568.5
132	300	230	12	6.0	265	M12x20	3.0	38	80	10	41.0	586.0
160	350	250	15	6.0	300	M16x25	3.0	42	110	12	45.0	616.0
180	350	250	15	6.0	300	M16x25	3.0	48	110	14	51.5	616.0
200	400	300	20	6.0	350	M16x29	7.0	55	110	16	59.0	656.5
225	450	350	20	6.0	400	M16x29	7.0	60	140	18	64.0	663.0

① ISO 4014 ② DIN 5480 ③ DIN 332-D ④ DIN 332 ⑤ Feather key/keyway DIN 6885 ⑦ ISO 4762 ⑧ Without locating shoulder +1 mm

SIMOGEAR Gearboxes

Bevel gearbox with adapter K4

Dimensions

K.F.129 gearbox in a flange-mounted design

KF030K4, KAF030K4, KAFS030K4, KAFT030K4

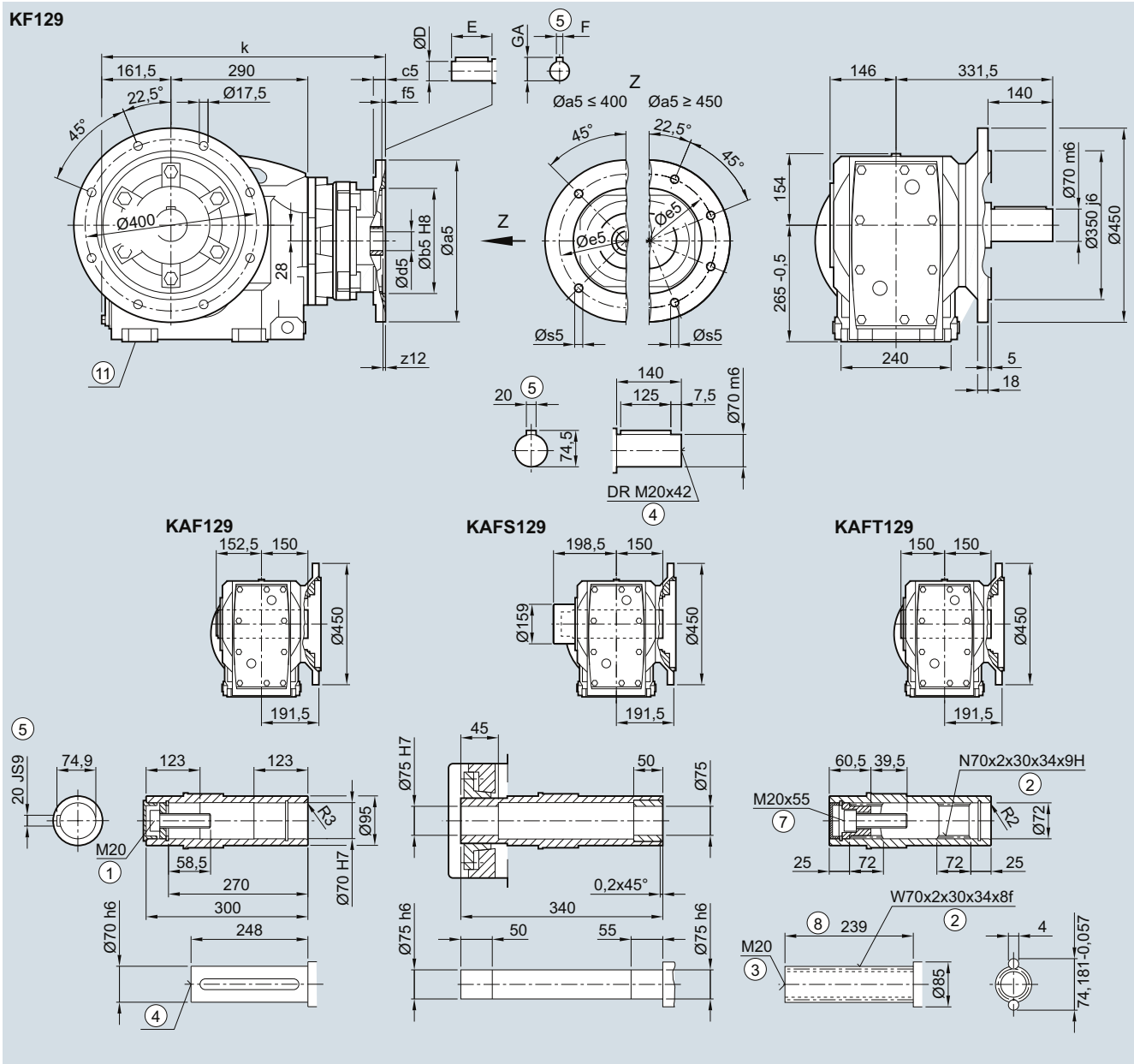

Adapter	a5	b5	c5	f5	e5	s5	z12	d5/D	E	F	GA	k
90	200	130	15	4.5	165	M10	4.0	24	50	8	27.0	521.5
100	250	180	14	5.0	215	M12x21	7.5	28	60	8	31.0	570.0
112	250	180	14	5.0	215	M12x21	7.5	28	60	8	31.0	570.0
132	300	230	12	6.0	265	M12x20	3.0	38	80	10	41.0	587.5
160	350	250	15	6.0	300	M16x25	3.0	42	110	12	45.0	617.5
180	350	250	15	6.0	300	M16x25	3.0	48	110	14	51.5	617.5
200	400	300	20	6.0	350	M16x29	7.0	55	110	16	59.0	658.0
225	450	350	20	6.0	400	M16x29	7.0	60	140	18	64.0	664.5

① ISO 4014

② DIN 5480

③ DIN 332-D

④ DIN 332

⑤ Feather key/keyway DIN 6885

⑥ ISO 4762

⑦ Without locating shoulder +1 mm

⑧ Use bores only for foot-mounted design

K.Z.129 in a housing flange design

KZ030K4, KAZ030K4, KAZS030K4, KAZT030K4

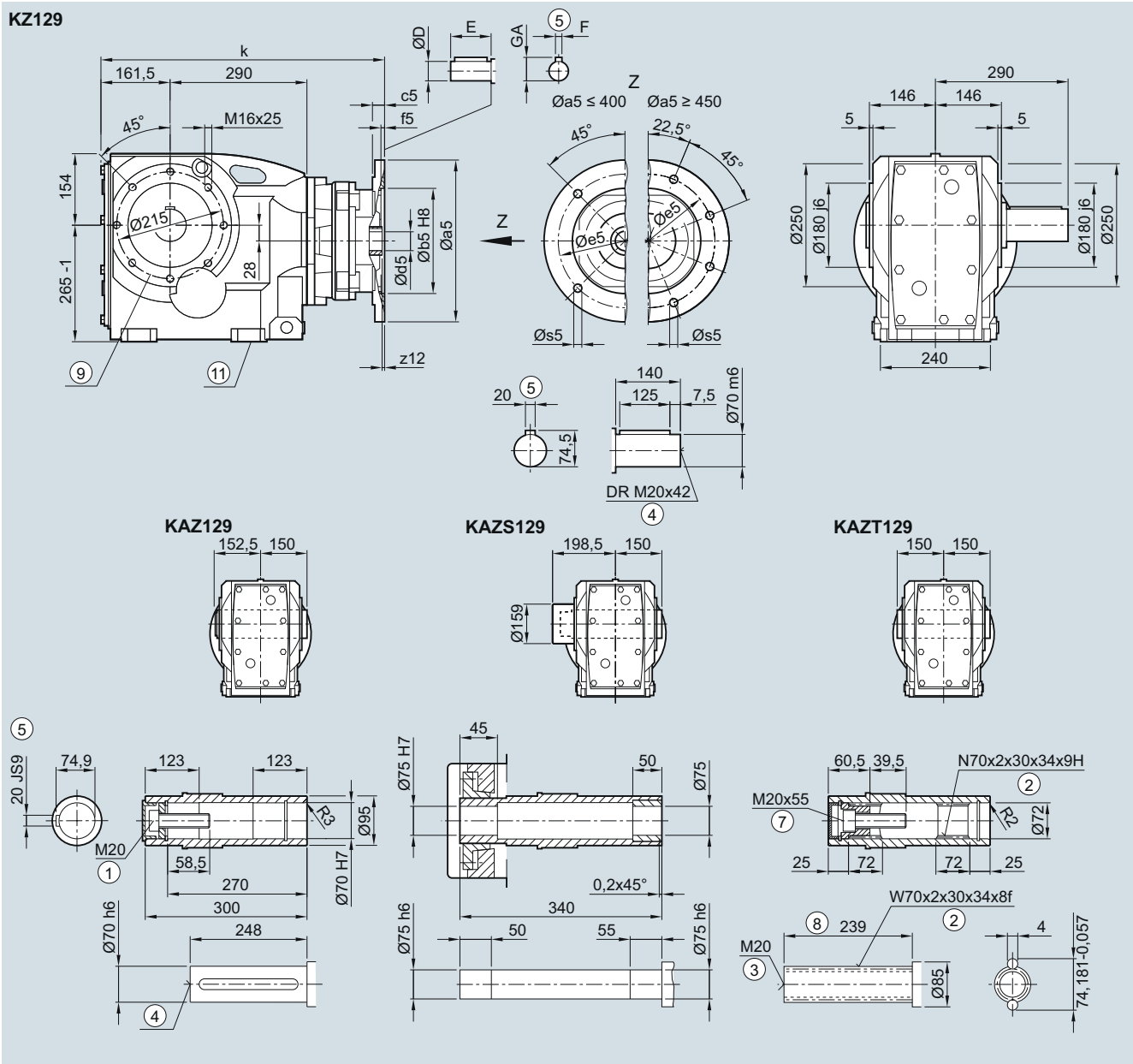

Adapter	a5	b5	c5	f5	e5	s5	z12	d5/D	E	F	GA	k
90	200	130	15	4.5	165	M10	4.0	24	50	8	27.0	521.5
100	250	180	14	5.0	215	M12x21	7.5	28	60	8	31.0	570.0
112	250	180	14	5.0	215	M12x21	7.5	28	60	8	31.0	570.0
132	300	230	12	6.0	265	M12x20	3.0	38	80	10	41.0	587.5
160	350	250	15	6.0	300	M16x25	3.0	42	110	12	45.0	617.5
180	350	250	15	6.0	300	M16x25	3.0	48	110	14	51.5	617.5
200	400	300	20	6.0	350	M16x29	7.0	55	110	16	59.0	658.0
225	450	350	20	6.0	400	M16x29	7.0	60	140	18	64.0	664.5

① ISO 4014 ② DIN 5480 ③ DIN 332-D ④ DIN 332 ⑤ Feather key/keyway DIN 6885
 ⑦ ISO 4762 ⑧ Without locating shoulder +1 mm ⑨ For pin holes, see 4/131 ⑩ Use bores only for foot-mounted design

SIMOGEAR Gearboxes

Bevel gearbox with adapter K4

Dimensions

KAD.129 gearbox in a shaft-mounted design

KAD030K4, KADS030K4, KADT030K4

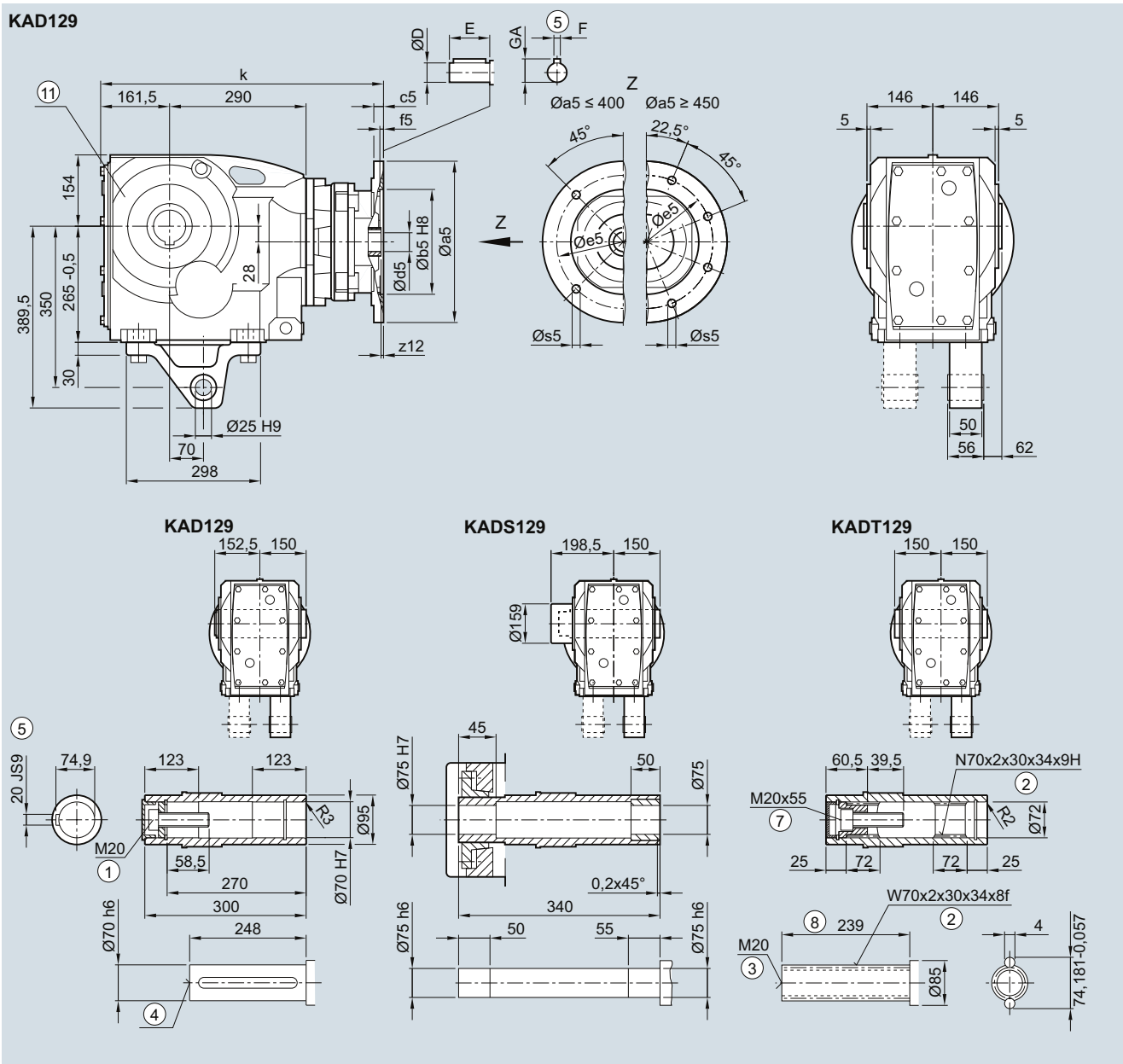

Adapter	a5	b5	c5	f5	e5	s5	z12	d5/D	E	F	GA	k
90	200	130	15	4.5	165	M10	4.0	24	50	8	27.0	521.5
100	250	180	14	5.0	215	M12x21	7.5	28	60	8	31.0	570.0
112	250	180	14	5.0	215	M12x21	7.5	28	60	8	31.0	570.0
132	300	230	12	6.0	265	M12x20	3.0	38	80	10	41.0	587.5
160	350	250	15	6.0	300	M16x25	3.0	42	110	12	45.0	617.5
180	350	250	15	6.0	300	M16x25	3.0	48	110	14	51.5	617.5
200	400	300	20	6.0	350	M16x29	7.0	55	110	16	59.0	658.0
225	450	350	20	6.0	400	M16x29	7.0	60	140	18	64.0	664.5

① ISO 4014 ② DIN 5480 ③ DIN 332-D ④ DIN 332 ⑤ Feather key/keyway DIN 6885
 ⑦ ISO 4762 ⑧ Without locating shoulder +1 mm ⑥ Use bores only for housing flange design

5

K.149 gearbox in a foot-mounted design

K030K4, KA030K4, KAS030K4, KAT030K4

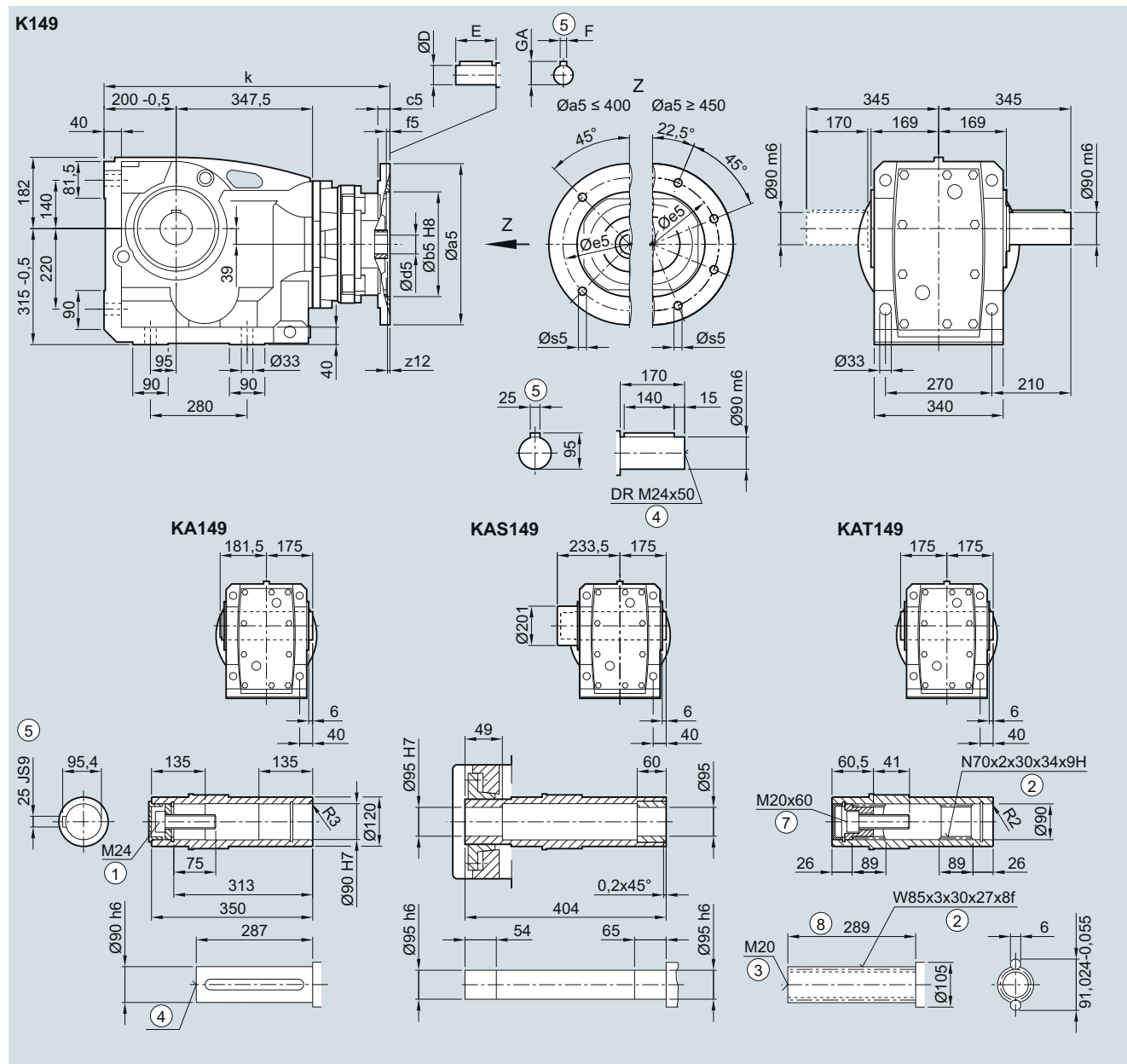

Adapter	a5	b5	c5	f5	e5	s5	z12	d5/D	E	F	GA	k
90	200	130	15	4.5	165	M10	4.0	24	50	8	27.0	610.5
100	250	180	14	5.0	215	M12x21	7.5	28	60	8	31.0	657.0
112	250	180	14	5.0	215	M12x21	7.5	28	60	8	31.0	657.0
132	300	230	12	6.0	265	M12x20	3.0	38	80	10	41.0	672.5
160	350	250	15	6.0	300	M16x25	3.0	42	110	12	45.0	702.5
180	350	250	15	6.0	300	M16x25	3.0	48	110	14	51.5	702.5
200	400	300	20	6.0	350	M16x29	7.0	55	110	16	59.0	743.0
225	450	350	20	6.0	400	M16x29	7.0	60	140	18	64.0	755.5
250	550	450	20	6.0	500	M16x29	10.0	65	140	18	69.0	784.0

① ISO 4014 ② DIN 5480 ③ DIN 332-D ④ DIN 332 ⑤ Feather key/keyway DIN 6885 ⑦ ISO 4762 ⑧ Without locating shoulder +1 mm

SIMOGEAR Gearboxes

Bevel gearbox with adapter K4

Dimensions

K.F.149 gearbox in a flange-mounted design

KF030K4, KAF030K4, KAFS030K4, KAFT030K4

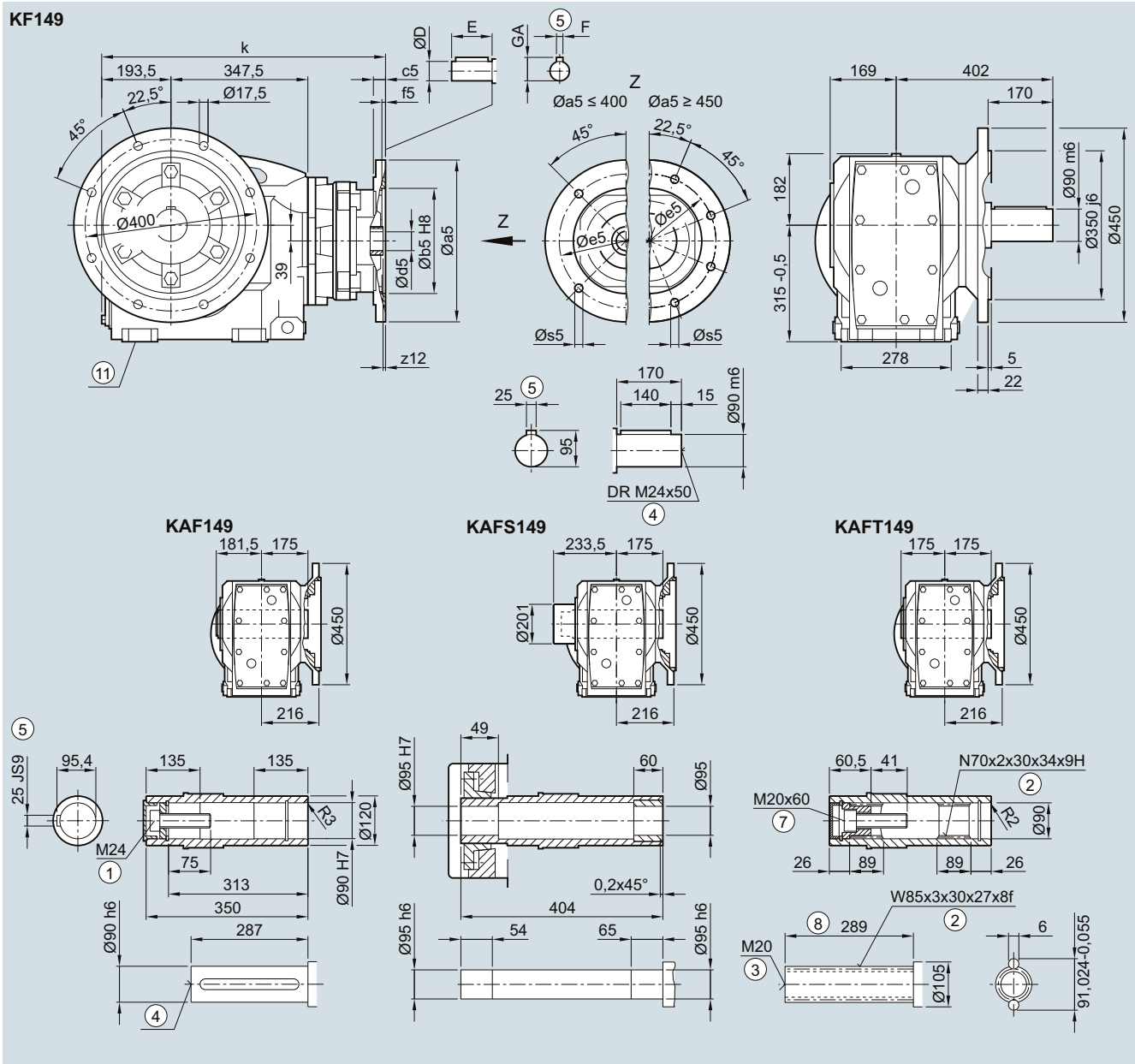

Adapter	a5	b5	c5	f5	e5	s5	z12	d5/D	E	F	GA	k
90	200	130	15	4.5	165	M10	4.0	24	50	8	27.0	604.0
100	250	180	14	5.0	215	M12x21	7.5	28	60	8	31.0	650.5
112	250	180	14	5.0	215	M12x21	7.5	28	60	8	31.0	650.5
132	300	230	12	6.0	265	M12x20	3.0	38	80	10	41.0	666.0
160	350	250	15	6.0	300	M16x25	3.0	42	110	12	45.0	696.0
180	350	250	15	6.0	300	M16x25	3.0	48	110	14	51.5	696.0
200	400	300	20	6.0	350	M16x29	7.0	55	110	16	59.0	736.5
225	450	350	20	6.0	400	M16x29	7.0	60	140	18	64.0	749.0
250	550	450	20	6.0	500	M16x29	10.0	65	140	18	69.0	777.5

① ISO 4014

② DIN 5480

③ DIN 332-D

④ DIN 332

⑤ Feather key/keyway DIN 6885

⑥ ISO 4762

⑧ Without locating shoulder +1 mm

⑨ Use bores only for foot-mounted design

K.Z.149 in a housing flange design

KZ030K4, KAZ030K4, KAZS030K4, KAZT030K4

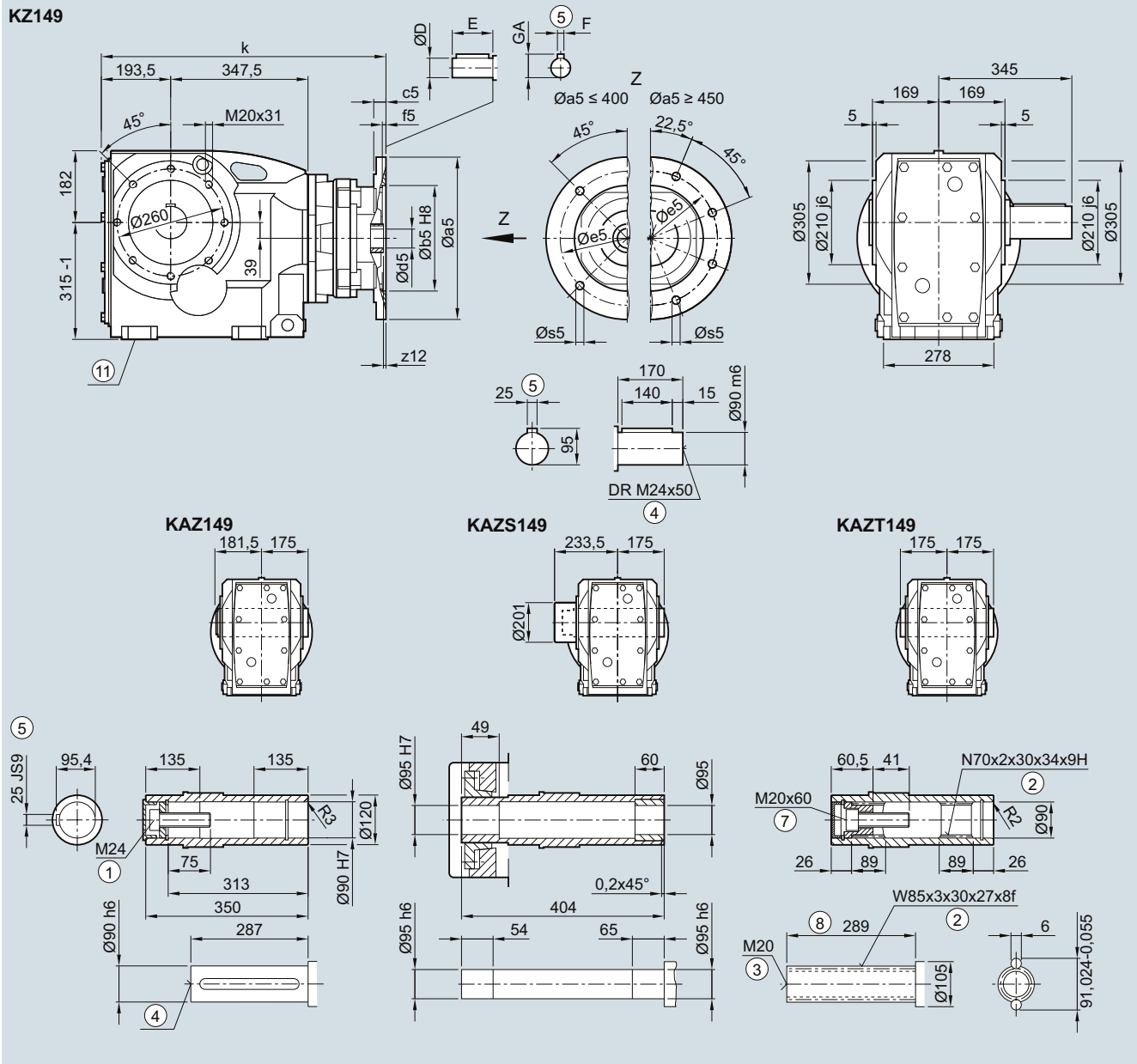

5

Adapter	a5	b5	c5	f5	e5	s5	z12	d5/D	E	F	GA	k
90	200	130	15	4.5	165	M10	4.0	24	50	8	27.0	604.0
100	250	180	14	5.0	215	M12x21	7.5	28	60	8	31.0	650.5
112	250	180	14	5.0	215	M12x21	7.5	28	60	8	31.0	650.5
132	300	230	12	6.0	265	M12x20	3.0	38	80	10	41.0	666.0
160	350	250	15	6.0	300	M16x25	3.0	42	110	12	45.0	696.0
180	350	250	15	6.0	300	M16x25	3.0	48	110	14	51.5	696.0
200	400	300	20	6.0	350	M16x29	7.0	55	110	16	59.0	736.5
225	450	350	20	6.0	400	M16x29	7.0	60	140	18	64.0	749.0
250	550	450	20	6.0	500	M16x29	10.0	65	140	18	69.0	777.5

① ISO 4014 ② DIN 5480 ③ DIN 332-D ④ DIN 332 ⑤ Feather key/keyway DIN 6885
 ⑦ ISO 4762 ⑧ Without locating shoulder +1 mm ⑨ Use bores only for foot-mounted design

SIMOGEAR Gearboxes

Bevel gearbox with adapter K4

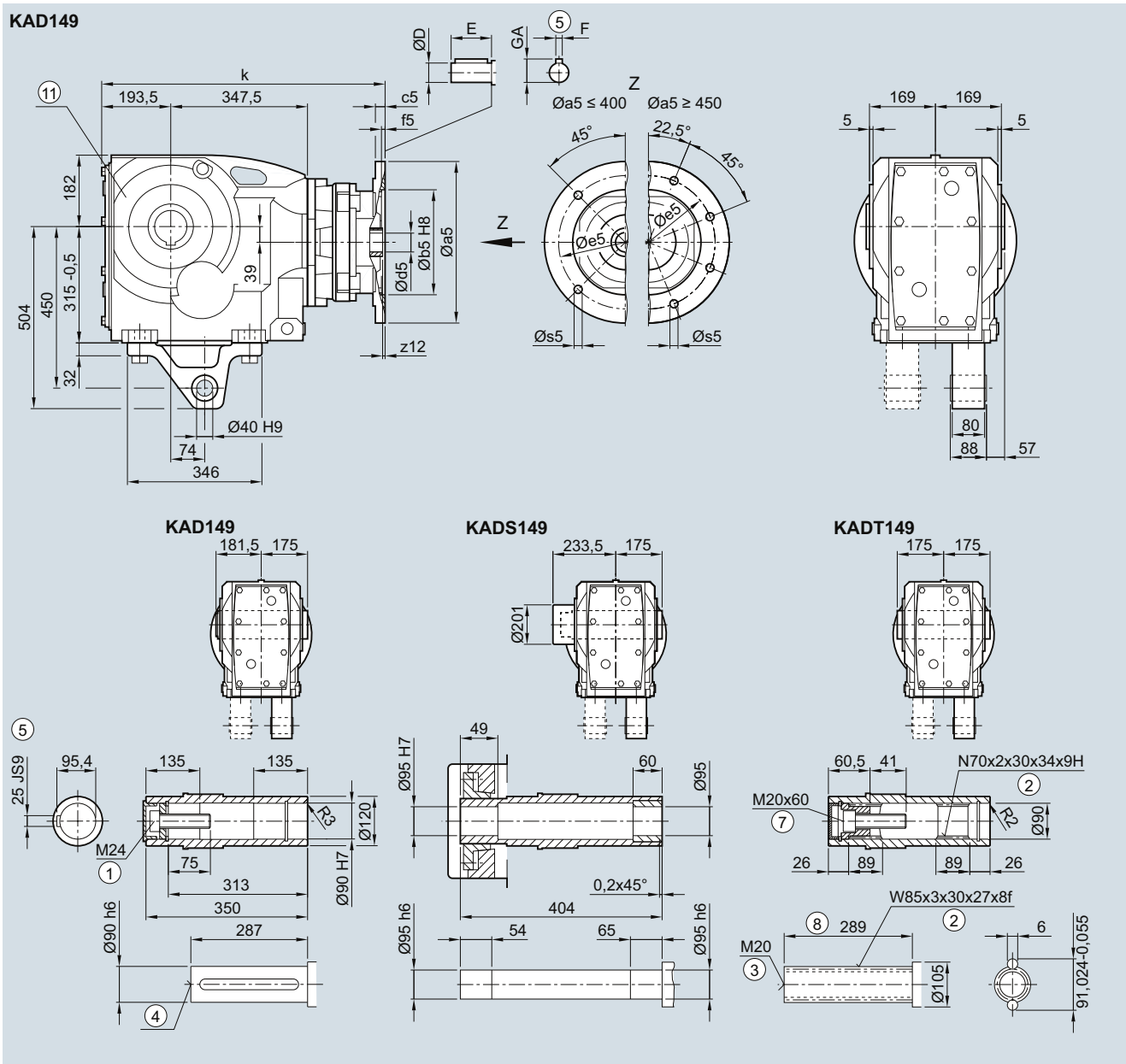
Dimensions**KAD.149 gearbox in a shaft-mounted design****KAD030K4, KADS030K4, KADT030K4**

Adapter	a5	b5	c5	f5	e5	s5	z12	d5/D	E	F	GA	k
90	200	130	15	4.5	165	M10	4.0	24	50	8	27.0	604.0
100	250	180	14	5.0	215	M12x21	7.5	28	60	8	31.0	650.5
112	250	180	14	5.0	215	M12x21	7.5	28	60	8	31.0	650.5
132	300	230	12	6.0	265	M12x20	3.0	38	80	10	41.0	666.0
160	350	250	15	6.0	300	M16x25	3.0	42	110	12	45.0	696.0
180	350	250	15	6.0	300	M16x25	3.0	48	110	14	51.5	696.0
200	400	300	20	6.0	350	M16x29	7.0	55	110	16	59.0	736.5
225	450	350	20	6.0	400	M16x29	7.0	60	140	18	64.0	749.0
250	550	450	20	6.0	500	M16x29	10.0	65	140	18	69.0	777.5

① ISO 4014

② DIN 5480

③ DIN 332-D

④ DIN 332

⑤ Feather key/keyway DIN 6885

⑥ ISO 4762

⑦ Without locating shoulder +1 mm

⑧ Use bores only for housing flange design

K.169 gearbox in a foot-mounted design

K030K4, KA030K4, KAS030K4, KAT030K4

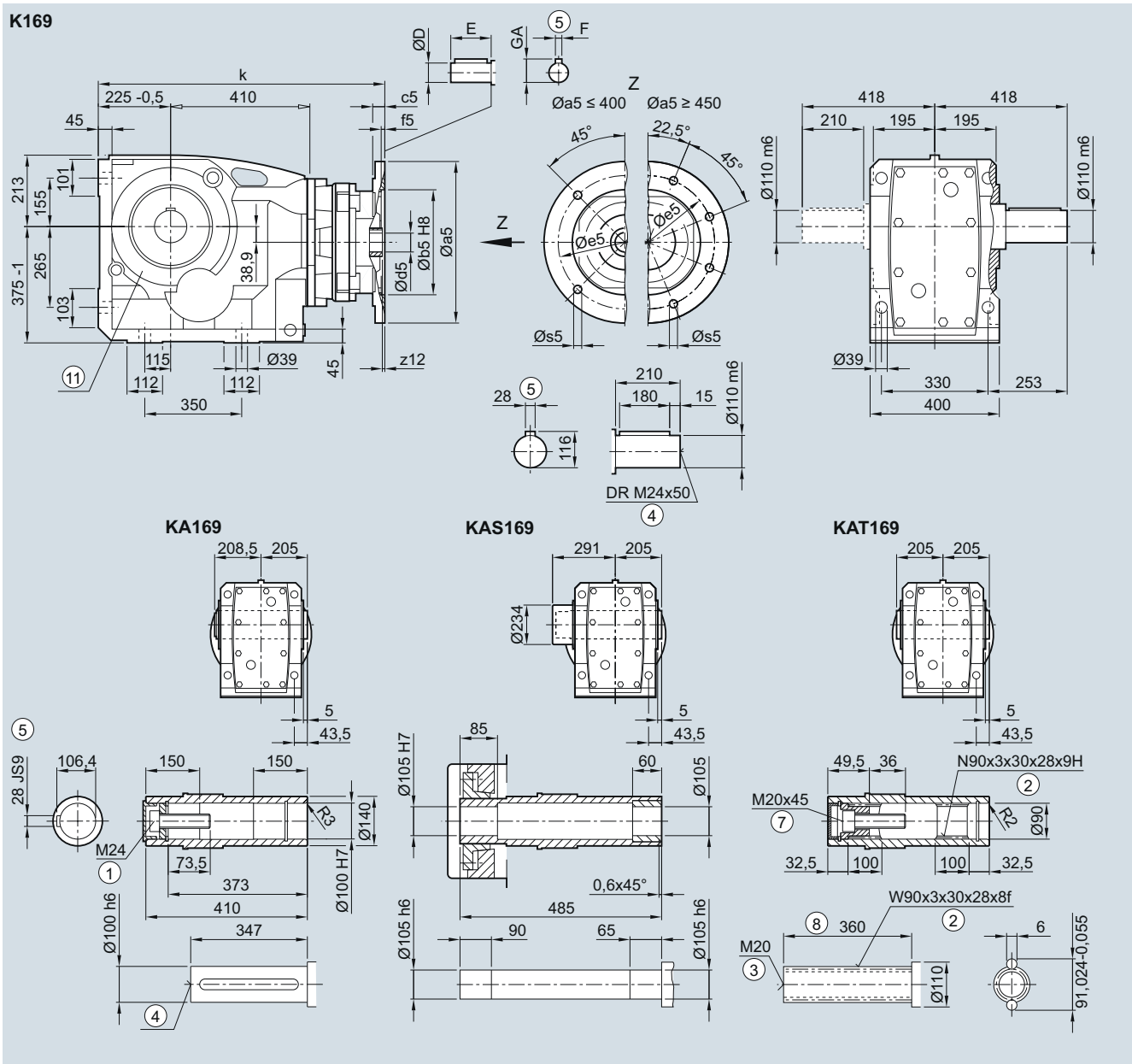

Adapter	a5	b5	c5	f5	e5	s5	z12	d5/D	E	F	GA	k
100	250	180	14	5.0	215	M12x21	7.5	28	60	8	31.0	743.0
112	250	180	14	5.0	215	M12x21	7.5	28	60	8	31.0	743.0
132	300	230	12	6.0	265	M12x20	3.0	38	80	10	41.0	753.5
160	350	250	15	6.0	300	M16x25	3.0	42	110	12	45.0	783.5
180	350	250	15	6.0	300	M16x25	3.0	48	110	14	51.5	783.5
200	400	300	20	6.0	350	M16x29	7.0	55	110	16	59.0	824.0
225	450	350	20	6.0	400	M16x29	7.0	60	140	18	64.0	830.5
250	550	450	20	6.0	500	M16x29	10.0	65	140	18	69.0	865.0

SIMOGEAR Gearboxes

Bevel gearbox with adapter K4

Dimensions

K.F.169 gearbox in a flange-mounted design

KF030K4, KAF030K4, KAFS030K4, KAFT030K4

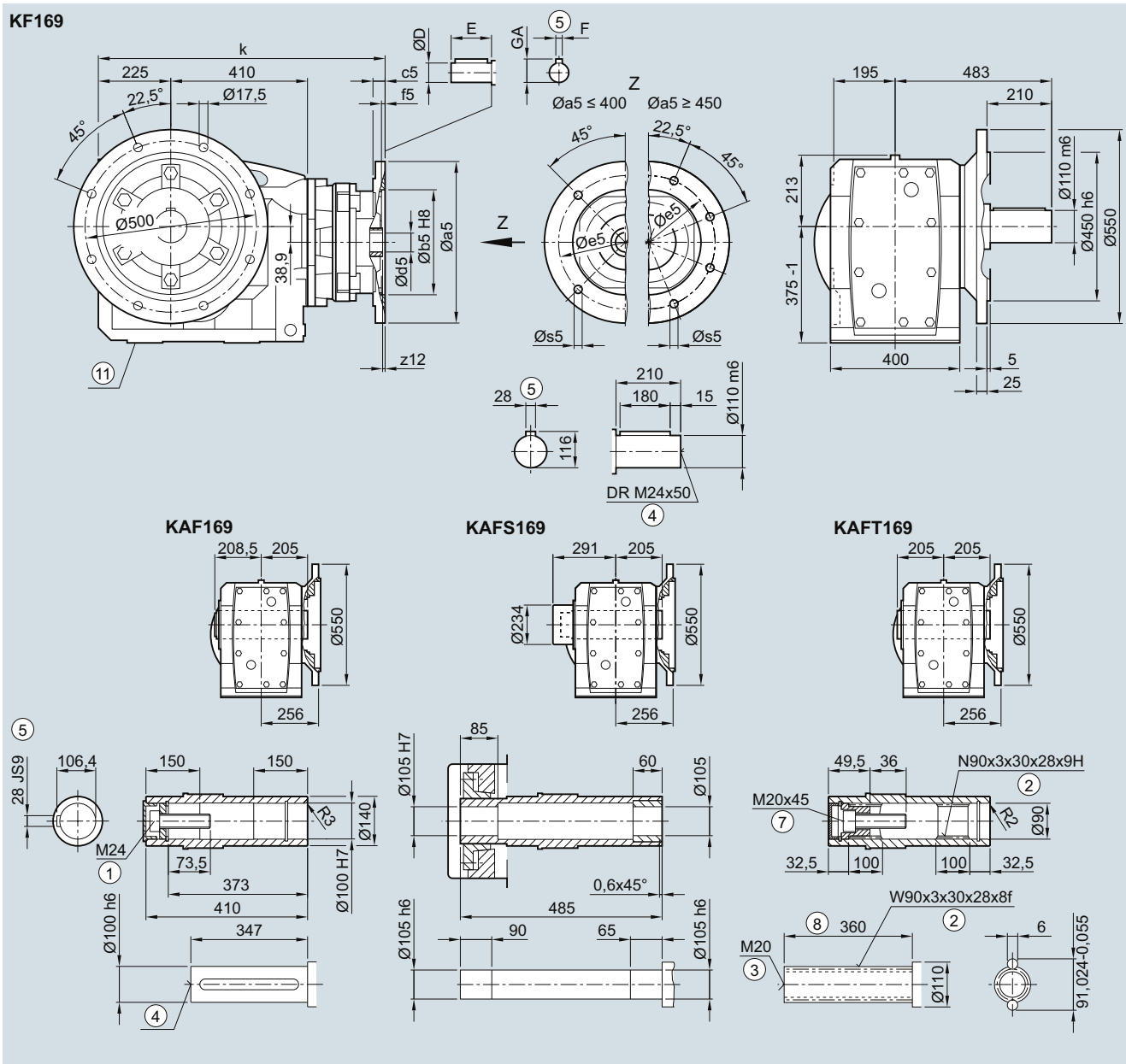

Adapter	a5	b5	c5	f5	e5	s5	z12	d5/D	E	F	GA	k
100	250	180	14	5.0	215	M12x21	7.5	28	60	8	31.0	743.0
112	250	180	14	5.0	215	M12x21	7.5	28	60	8	31.0	743.0
132	300	230	12	6.0	265	M12x20	3.0	38	80	10	41.0	753.5
160	350	250	15	6.0	300	M16x25	3.0	42	110	12	45.0	783.5
180	350	250	15	6.0	300	M16x25	3.0	48	110	14	51.5	783.5
200	400	300	20	6.0	350	M16x29	7.0	55	110	16	59.0	824.0
225	450	350	20	6.0	400	M16x29	7.0	60	140	18	64.0	830.5
250	550	450	20	6.0	500	M16x29	10.0	65	140	18	69.0	865.0

① ISO 4014

② DIN 5480

③ DIN 332-D

④ DIN 332

⑤ Feather key/keyway DIN 6885

⑦ ISO 4762

⑧ Without locating shoulder +1 mm

⑨ Use bores only for foot-mounted design

K.Z.169 gearbox in a housing flange design

KZ030K4, KAZ030K4, KAZS030K4, KAZT030K4

KZ169

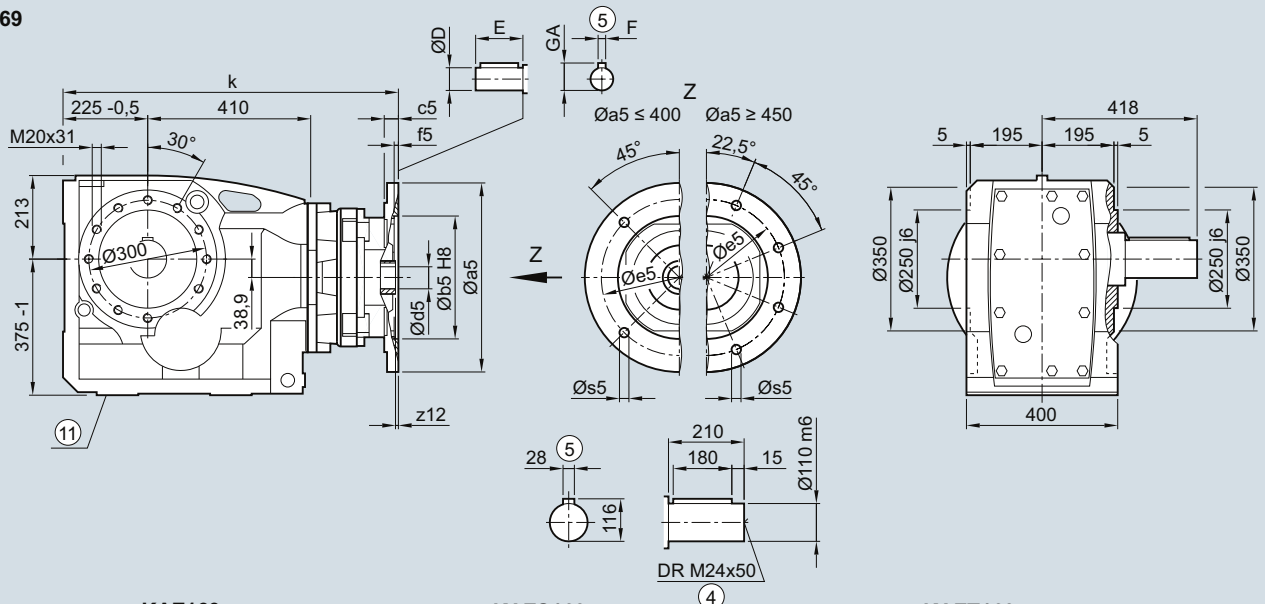

KAZ169

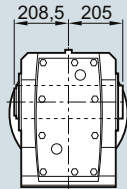

KAZS169

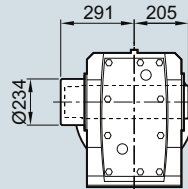

KAZT169

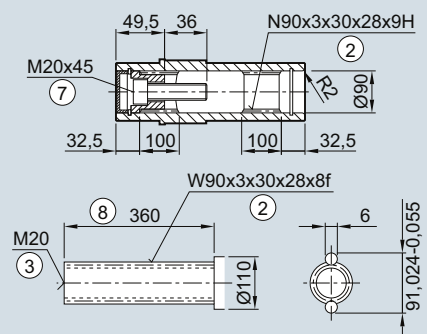
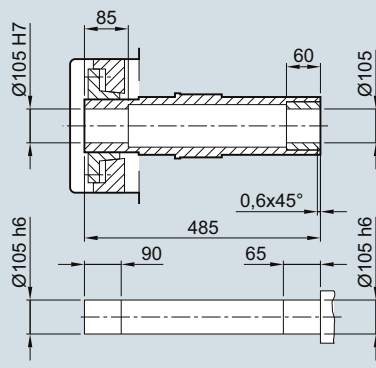
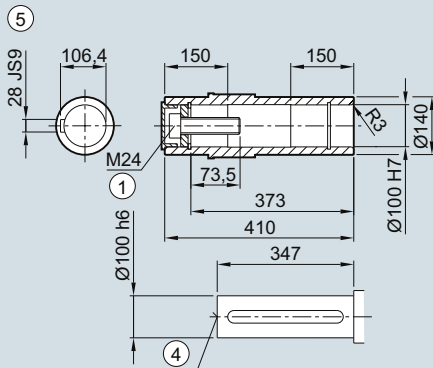
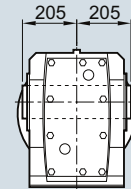

Adapter	a5	b5	c5	f5	e5	s5	z12	d5/D	E	F	GA	k
100	250	180	14	5.0	215	M12x21	7.5	28	60	8	31.0	743.0
112	250	180	14	5.0	215	M12x21	7.5	28	60	8	31.0	743.0
132	300	230	12	6.0	265	M12x20	3.0	38	80	10	41.0	753.5
160	350	250	15	6.0	300	M16x25	3.0	42	110	12	45.0	783.5
180	350	250	15	6.0	300	M16x25	3.0	48	110	14	51.5	783.5
200	400	300	20	6.0	350	M16x29	7.0	55	110	16	59.0	824.0
225	450	350	20	6.0	400	M16x29	7.0	60	140	18	64.0	830.5
250	550	450	20	6.0	500	M16x29	10.0	65	140	18	69.0	865.0

① ISO 4014 ② DIN 5480 ③ DIN 332-D ④ DIN 332 ⑤ Feather key/keyway DIN 6885
 ⑦ ISO 4762 ⑧ Without locating shoulder +1 mm ⑨ Use bores only for foot-mounted design

SIMOGEAR Gearboxes

Bevel gearbox with adapter K4

Dimensions

KAD.169 gearbox in a shaft-mounted design

KAD030K4, KADS030K4, KADT030K4

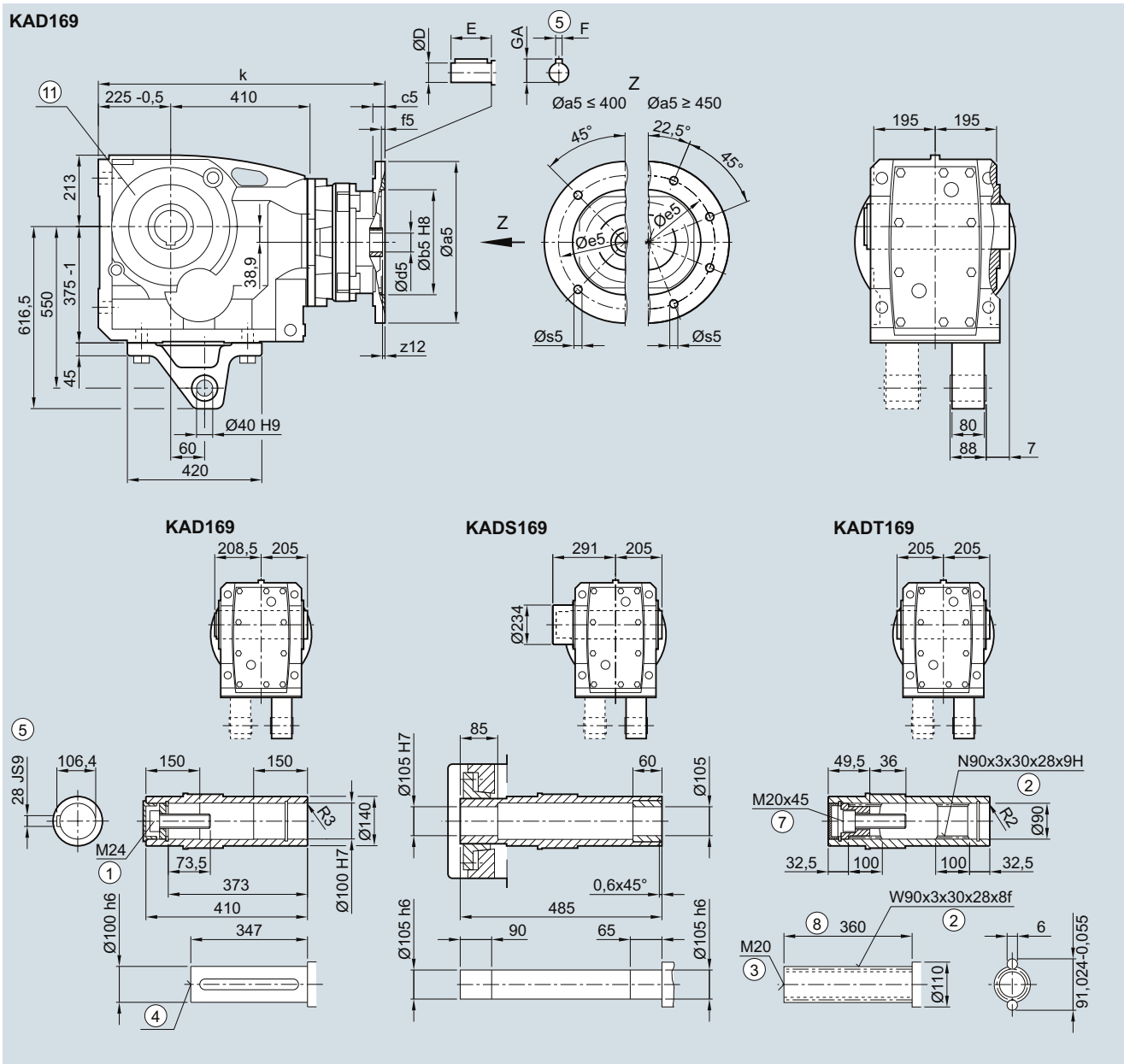

Adapter	a5	b5	c5	f5	e5	s5	z12	d5/D	E	F	GA	k
100	250	180	14	5.0	215	M12x21	7.5	28	60	8	31.0	743.0
112	250	180	14	5.0	215	M12x21	7.5	28	60	8	31.0	743.0
132	300	230	12	6.0	265	M12x20	3.0	38	80	10	41.0	753.5
160	350	250	15	6.0	300	M16x25	3.0	42	110	12	45.0	783.5
180	350	250	15	6.0	300	M16x25	3.0	48	110	14	51.5	783.5
200	400	300	20	6.0	350	M16x29	7.0	55	110	16	59.0	824.0
225	450	350	20	6.0	400	M16x29	7.0	60	140	18	64.0	830.5
250	550	450	20	6.0	500	M16x29	10.0	65	140	18	69.0	865.0

① ISO 4014

② DIN 5480

③ DIN 332-D

④ DIN 332

⑤ Feather key/keyway DIN 6885

⑦ ISO 4762

⑧ Without locating shoulder +1 mm

⑨ Use bores only for housing flange design

K.189 gearbox in a foot-mounted design

K030K4, KA030K4, KAS030K4, KAT030K4

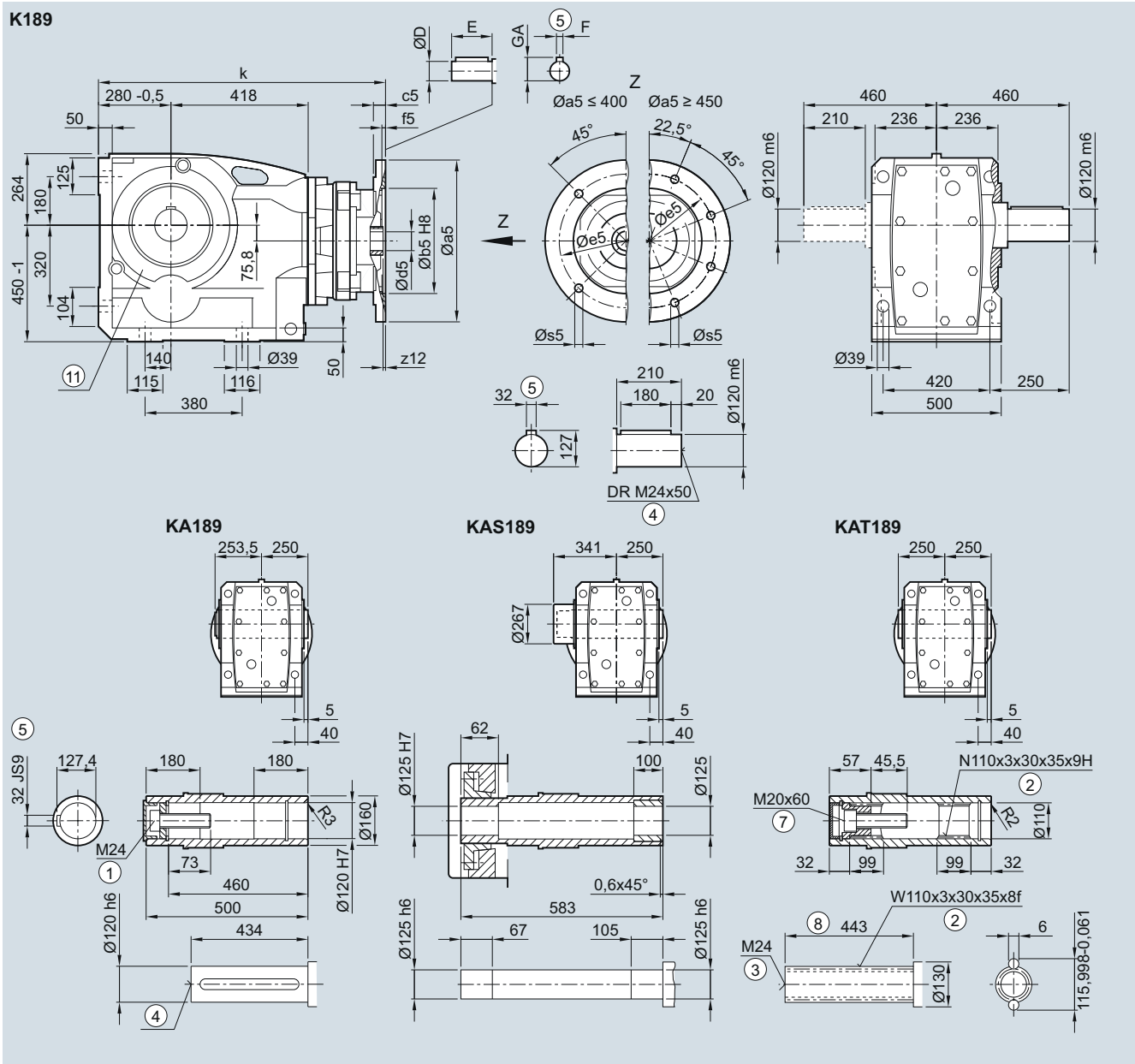

Adapter	a5	b5	c5	f5	e5	s5	z12	d5/D	E	F	GA	k
112	250	180	14	5.0	215	M12x21	7.5	28	60	8	31.0	793.5
132	300	230	12	6.0	265	M12x20	3.0	38	80	10	41.0	803.5
160	350	250	15	6.0	300	M16x25	3.0	42	110	12	45.0	833.5
180	350	250	15	6.0	300	M16x25	3.0	48	110	14	51.5	833.5
200	400	300	20	6.0	350	M16x29	7.0	55	110	16	59.0	873.5
225	450	350	20	6.0	400	M16x29	7.0	60	140	18	64.0	879.0
250	550	450	20	6.0	500	M16x29	10.0	65	140	18	69.0	909.5

① ISO 4014 ② DIN 5480 ③ DIN 332-D ④ DIN 332 ⑤ Feather key/keyway DIN 6885
 ⑦ ISO 4762 ⑧ Without locating shoulder +1 mm ⑨ Use bores only for housing flange design

SIMOGEAR Gearboxes

Bevel gearbox with adapter K4

Dimensions

K.F.189 gearbox in a flange-mounted design

KF030K4, KAF030K4, KAFS030K4, KAFT030K4

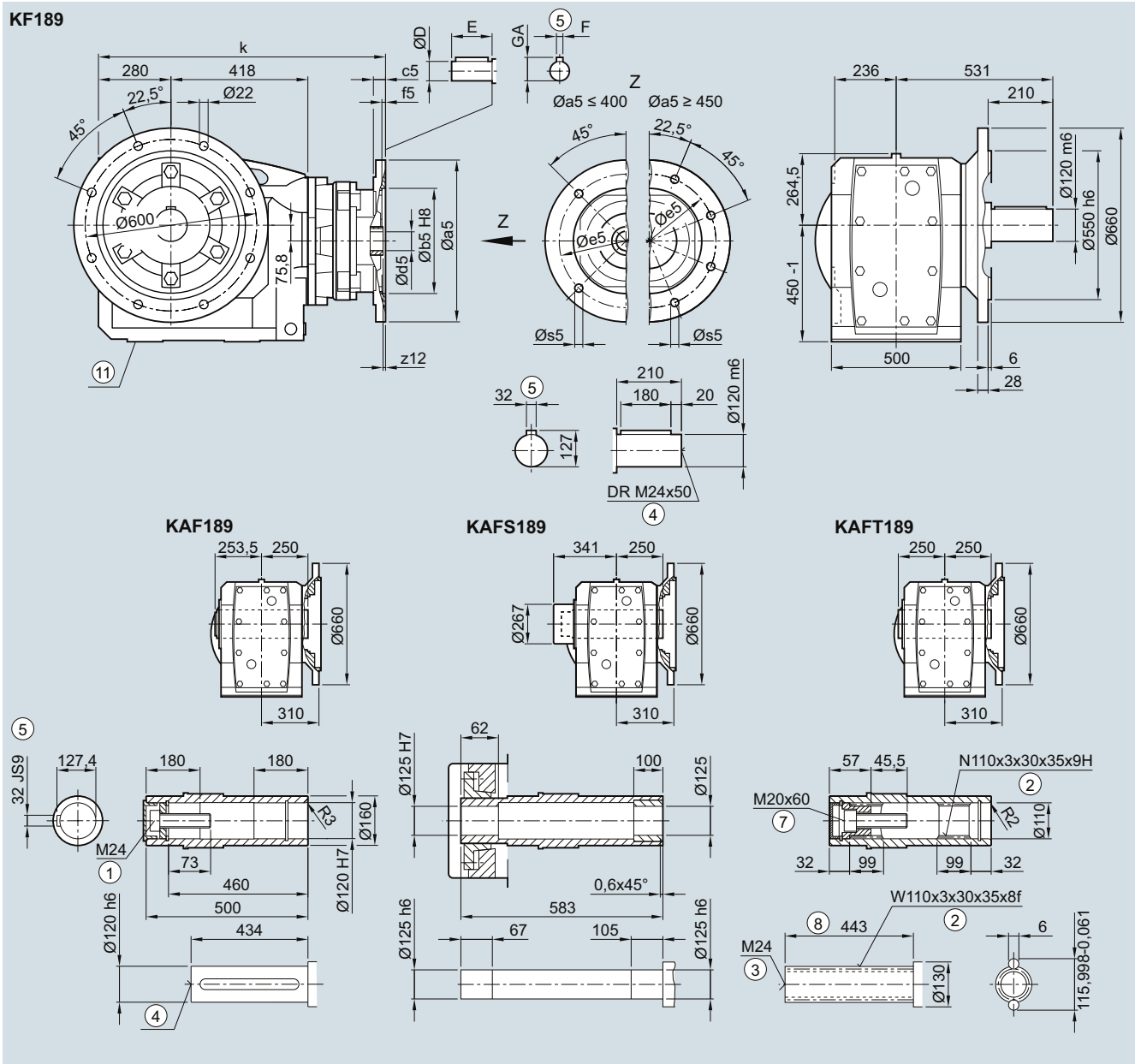

Adapter	a5	b5	c5	f5	e5	s5	z12	d5/D	E	F	GA	k
112	250	180	14	5.0	215	M12x21	7.5	28	60	8	31.0	793.5
132	300	230	12	6.0	265	M12x20	3.0	38	80	10	41.0	803.5
160	350	250	15	6.0	300	M16x25	3.0	42	110	12	45.0	833.5
180	350	250	15	6.0	300	M16x25	3.0	48	110	14	51.5	833.5
200	400	300	20	6.0	350	M16x29	7.0	55	110	16	59.0	873.5
225	450	350	20	6.0	400	M16x29	7.0	60	140	18	64.0	879.0
250	550	450	20	6.0	500	M16x29	10.0	65	140	18	69.0	909.5

① ISO 4014

② DIN 5480

③ DIN 332-D

④ DIN 332

⑤ Feather key/keyway DIN 6885

⑥ ISO 4762

⑦ Without locating shoulder +1 mm

⑧ Use bores only for foot-mounted design

K.Z.189 gearbox in a housing flange design

KZ030K4, KAZ030K4, KAZS030K4, KAZT030K4

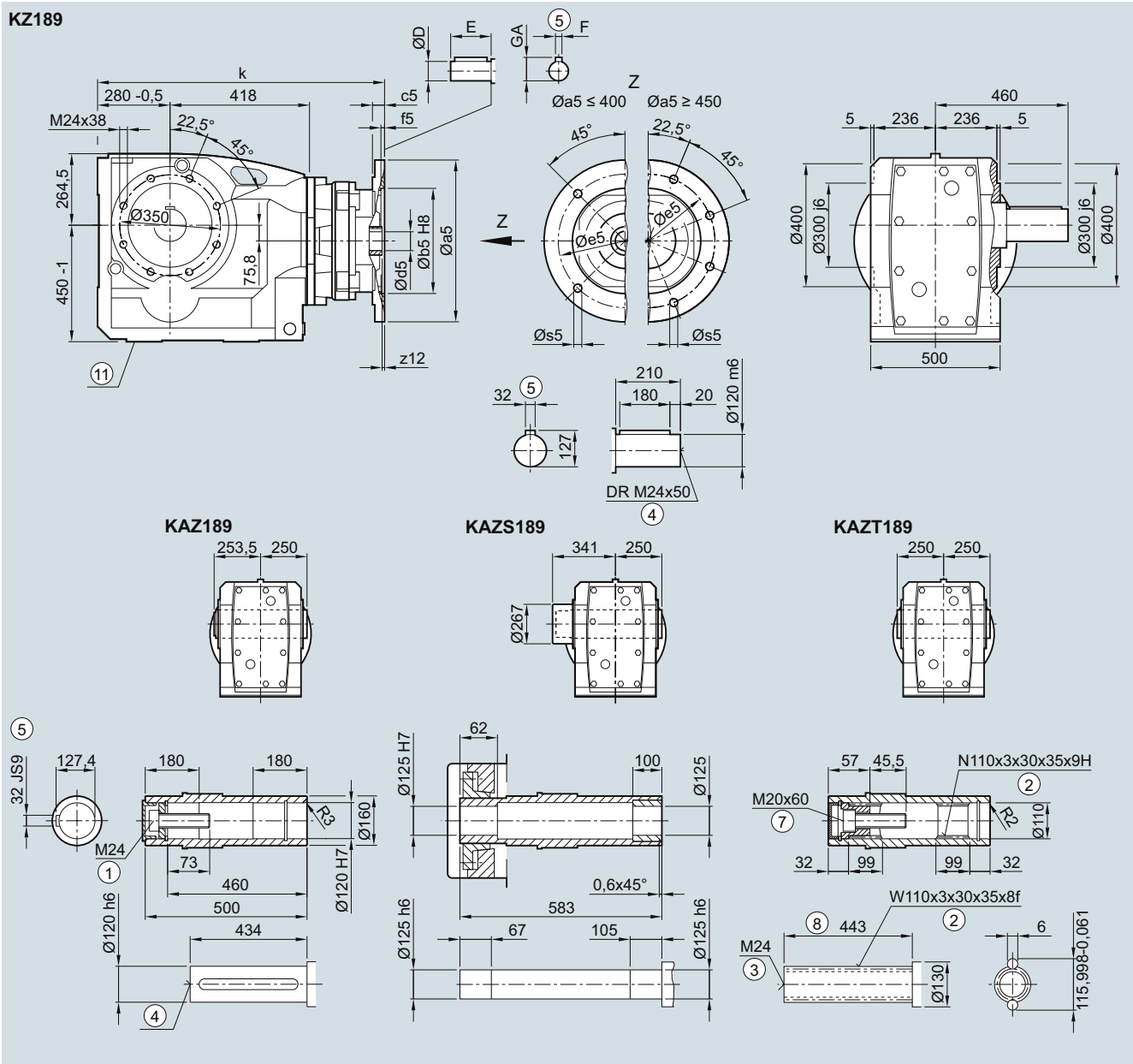

Adapter	a5	b5	c5	f5	e5	s5	z12	d5/D	E	F	GA	k
112	250	180	14	5.0	215	M12x21	7.5	28	60	8	31.0	793.5
132	300	230	12	6.0	265	M12x20	3.0	38	80	10	41.0	803.5
160	350	250	15	6.0	300	M16x25	3.0	42	110	12	45.0	833.5
180	350	250	15	6.0	300	M16x25	3.0	48	110	14	51.5	833.5
200	400	300	20	6.0	350	M16x29	7.0	55	110	16	59.0	873.5
225	450	350	20	6.0	400	M16x29	7.0	60	140	18	64.0	879.0
250	550	450	20	6.0	500	M16x29	10.0	65	140	18	69.0	909.5

① ISO 4014 ② DIN 5480 ③ DIN 332-D ④ DIN 332 ⑤ Feather key/keyway DIN 6885
 ⑦ ISO 4762 ⑧ Without locating shoulder +1 mm ⑨ Use bores only for foot-mounted design

SIMOGEAR Gearboxes

Bevel gearbox with adapter K4

Dimensions

KAD.189 gearbox in a shaft-mounted design

KAD030K4, KADS030K4, KADT030K4

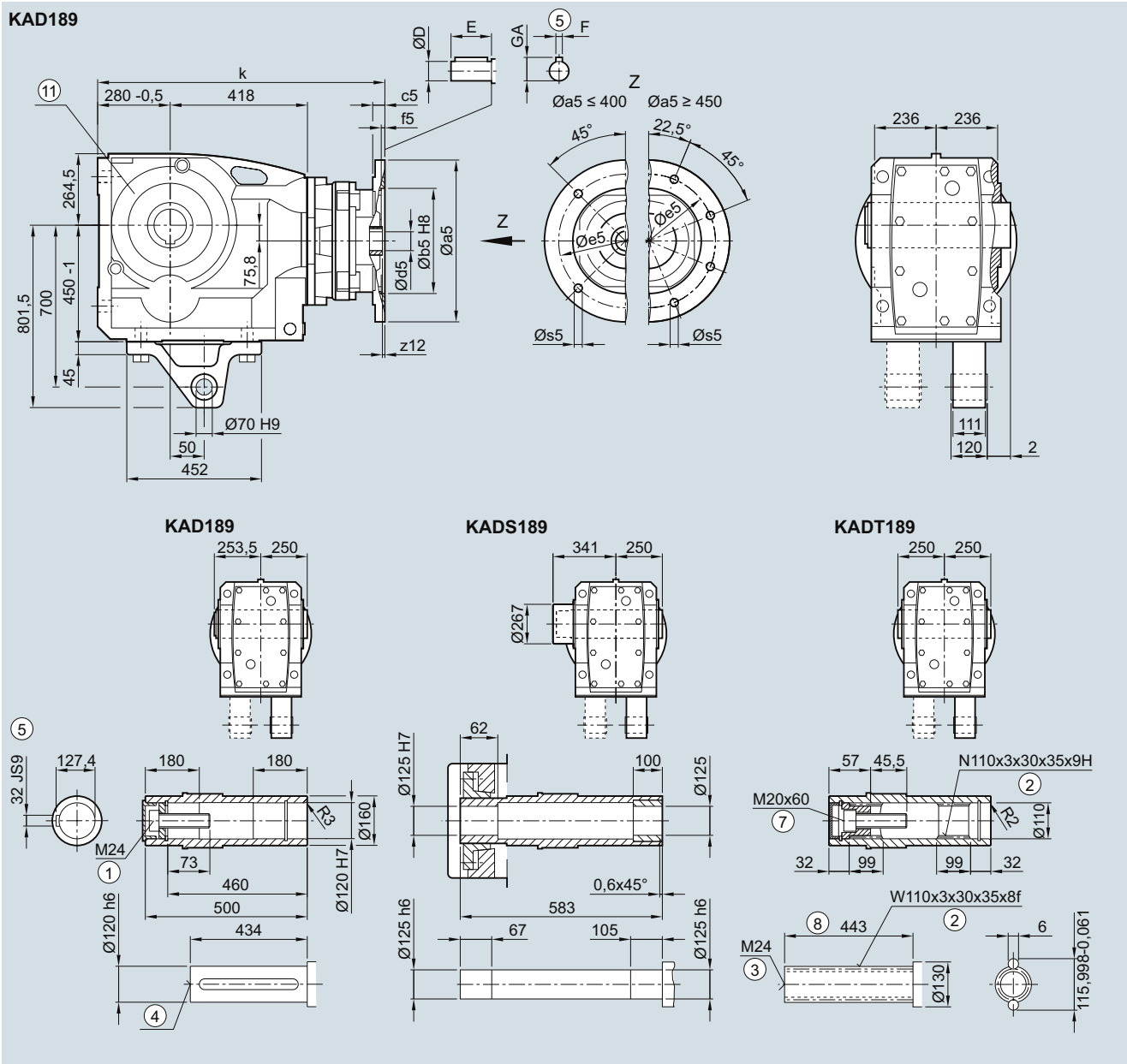

Adapter	a5	b5	c5	f5	e5	s5	z12	d5/D	E	F	GA	k
112	250	180	14	5.0	215	M12x21	7.5	28	60	8	31.0	793.5
132	300	230	12	6.0	265	M12x20	3.0	38	80	10	41.0	803.5
160	350	250	15	6.0	300	M16x25	3.0	42	110	12	45.0	833.5
180	350	250	15	6.0	300	M16x25	3.0	48	110	14	51.5	833.5
200	400	300	20	6.0	350	M16x29	7.0	55	110	16	59.0	873.5
225	450	350	20	6.0	400	M16x29	7.0	60	140	18	64.0	879.0
250	550	450	20	6.0	500	M16x29	10.0	65	140	18	69.0	909.5

① ISO 4014 ② DIN 5480 ③ DIN 332-D ④ DIN 332 ⑤ Feather key/keyway DIN 6885
 ⑦ ISO 4762 ⑧ Without locating shoulder +1 mm ⑨ Use bores only for housing flange design

5

B...29 to B...49 and K...39 to K...69 gearboxes

B..030K2, B.F.030K2, B.Z.030K2, BAD.030K2
K..030K2, K.F.030K2, K.Z.030K2, KAD.030K2

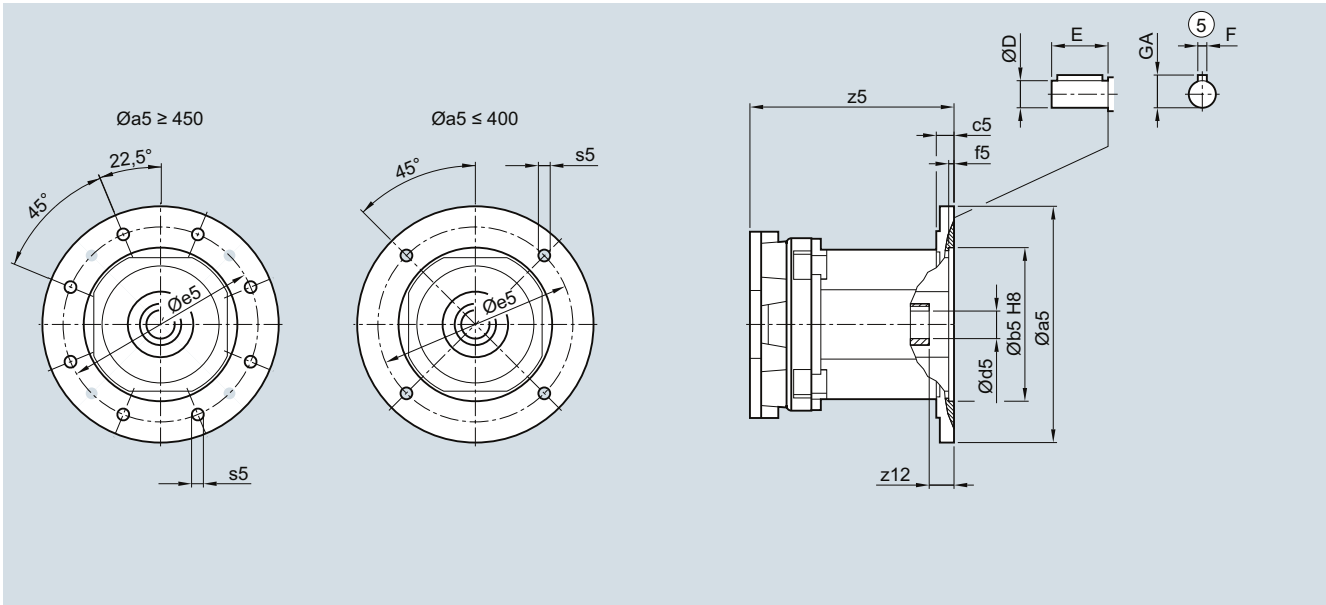

Adapter	a5	b5	c5	f5	e5	s5	z12	d5/D	E	F	GA	z5
B...29												
80	200	130	15	4.5	165	M10	15	19	40	6	21.5	198.0
90	200	130	15	4.5	165	M10	25	24	50	8	27.0	198.0
100	250	180	18	5.0	215	M12	30	28	60	8	31.0	245.0
B...39												
80	200	130	15	4.5	165	M10	15	19	40	6	21.5	198.0
90	200	130	15	4.5	165	M10	25	24	50	8	27.0	198.0
100	250	180	18	5.0	215	M12	30	28	60	8	31.0	245.0
112	250	180	18	5.0	215	M12	30	28	60	8	31.0	245.0
B...49												
80	200	130	15	4.5	165	M10	15	19	40	6	21.5	188.5
90	200	130	15	4.5	165	M10	25	24	50	8	27.0	188.5
100	250	180	18	5.0	215	M12	30	28	60	8	31.0	235.5
112	250	180	18	5.0	215	M12	30	28	60	8	31.0	235.5
132	300	230	18	5.0	265	M12	45	38	80	10	41.0	313.5
K...39												
80	200	130	15	4.5	165	M10	15	19	40	6	21.5	198.0
90	200	130	15	4.5	165	M10	25	24	50	8	27.0	198.0
100	250	180	18	5.0	215	M12	30	28	60	8	31.0	245.0
112	250	180	18	5.0	215	M12	30	28	60	8	31.0	245.0
K...49												
80	200	130	15	4.5	165	M10	15	19	40	6	21.5	188.5
90	200	130	15	4.5	165	M10	25	24	50	8	27.0	188.5
100	250	180	18	5.0	215	M12	30	28	60	8	31.0	235.5
112	250	180	18	5.0	215	M12	30	28	60	8	31.0	235.5
132	300	230	18	5.0	265	M12	45	38	80	10	41.0	313.5
K...69												
80	200	130	15	4.5	165	M10	15	19	40	6	21.5	188.5
90	200	130	15	4.5	165	M10	25	24	50	8	27.0	188.5
100	250	180	18	5.0	215	M12	30	28	60	8	31.0	235.5
112	250	180	18	5.0	215	M12	30	28	60	8	31.0	235.5
132	300	230	18	5.0	265	M12	45	38	80	10	41.0	313.5

⑤ Feather key/keyway DIN 6885

SIMOGEAR Gearboxes

Bevel gearbox with adapter K2

Dimensions

K...79 to K...129 gearboxes (continued)

B..030K2, B.F.030K2, B.Z.030K2, BAD.030K2
K..030K2, K.F.030K2, K.Z.030K2, KAD.030K2

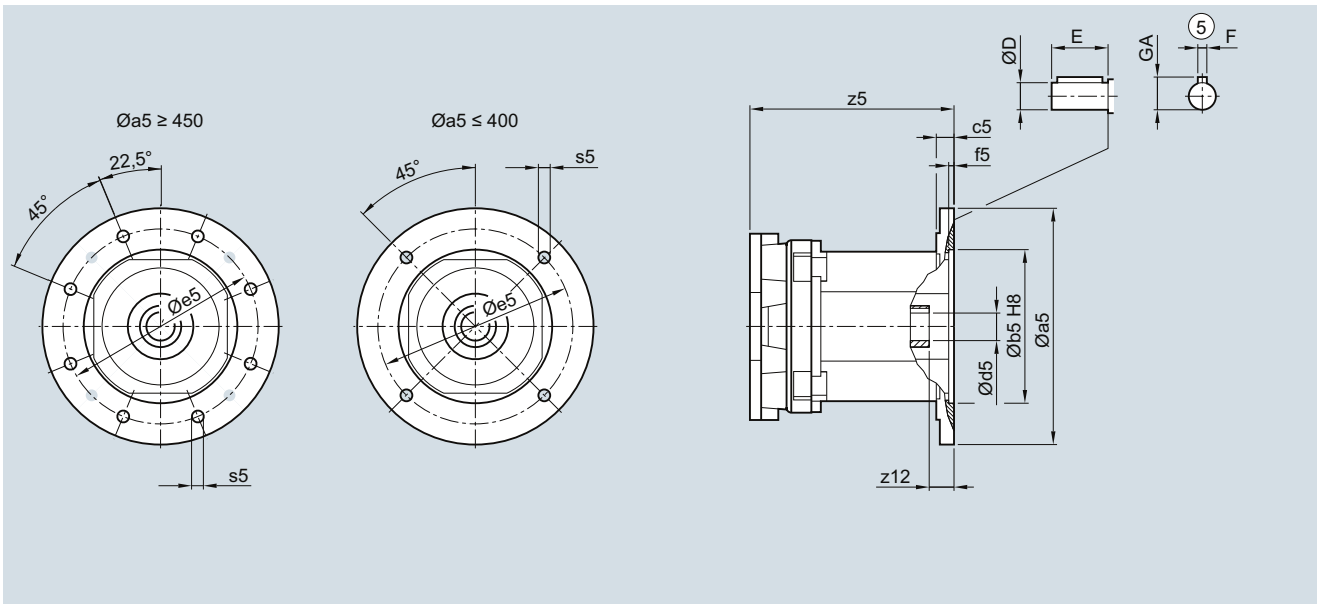

Adapter	a5	b5	c5	f5	e5	s5	z12	d5/D	E	F	GA	z5
K...79												
80	200	130	15	4.5	165	M10	15	19	40	6	21.5	188.5
90	200	130	15	4.5	165	M10	25	24	50	8	27.0	188.5
100	250	180	18	5.0	215	M12	30	28	60	8	31.0	235.5
112	250	180	18	5.0	215	M12	30	28	60	8	31.0	235.5
132	300	230	18	5.0	265	M12	45	38	80	10	41.0	313.5
K...89												
80	200	130	15	4.5	165	M10	15	19	40	6	21.5	182.5
90	200	130	15	4.5	165	M10	25	24	50	8	27.0	182.5
100	250	180	18	5.0	215	M12	30	28	60	8	31.0	229.5
112	250	180	18	5.0	215	M12	30	28	60	8	31.0	229.5
132	300	230	18	5.0	265	M12	45	38	80	10	41.0	307.5
160	350	250	25	6.0	300	M16	66	42	110	12	45.0	352.5
K...109												
80	200	130	15	4.5	165	M10	15	19	40	6	21.5	169.5
90	200	130	15	4.5	165	M10	25	24	50	8	27.0	169.5
100	250	180	18	5.0	215	M12	30	28	60	8	31.0	212.5
112	250	180	18	5.0	215	M12	30	28	60	8	31.0	212.5
132	300	230	18	5.0	265	M12	45	38	80	10	41.0	290.5
160	350	250	25	6.0	300	M16	66	42	110	12	45.0	335.5
180	350	250	25	6.0	300	M16	59	48	110	14	51.5	335.5
K...129												
90	200	130	15	4.5	165	M10	25	24	50	8	27.0	162.5
100	250	180	18	5.0	215	M12	30	28	60	8	31.0	203.5
112	250	180	18	5.0	215	M12	30	28	60	8	31.0	203.5
132	300	230	18	5.0	265	M12	45	38	80	10	41.0	281.5
160	350	250	25	6.0	300	M16	66	42	110	12	45.0	326.5
180	350	250	25	6.0	300	M16	59	48	110	14	51.5	326.5
200	400	300	20	6.0	350	M16x29	60	55	110	16	59.0	371.5
225	450	350	50	6.0	400	M16x29	84 (36)	60 (55)	140 (110)	18 (16)	64.0 (59.0)	419.0

⑤ Feather key/keyway DIN 6885

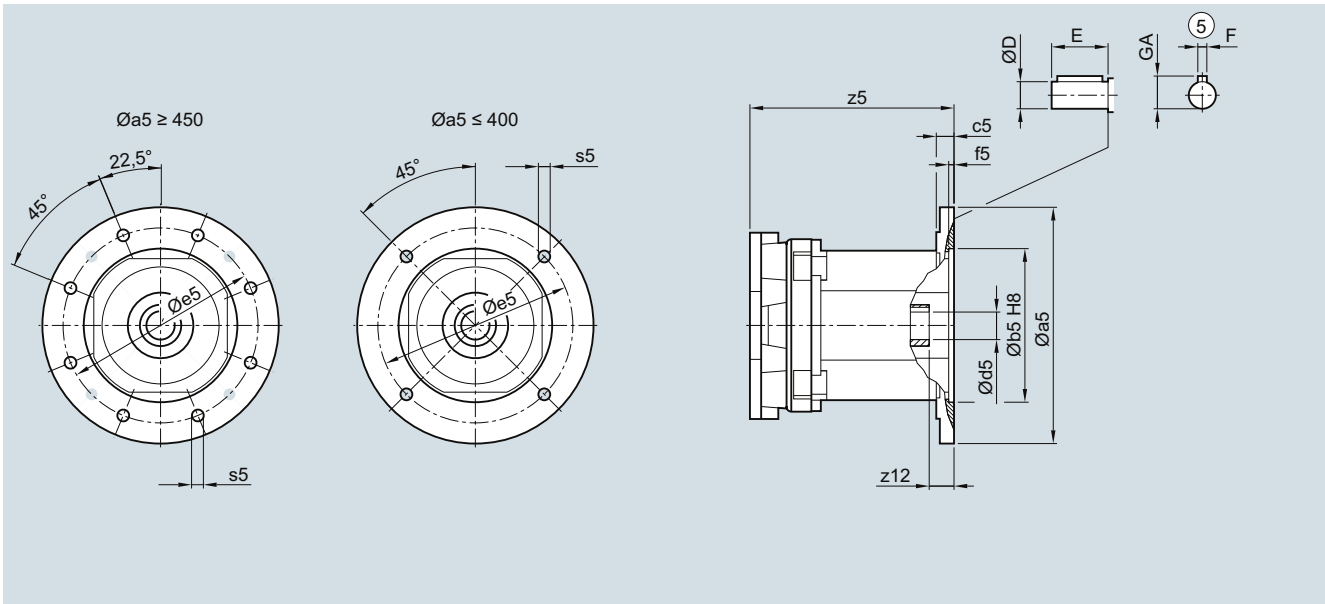
K...149 to K...189 gearboxes (continued)
K...030K2, K.F.030K2, K.Z.030K2, KAD.030K2

Adapter	a5	b5	c5	f5	e5	s5	z12	d5/D	E	F	GA	z5
K...149												
90	200	130	15	4.5	165	M10	25	24	50	8	27.0	155.5
100	250	180	18	5.0	215	M12	30	28	60	8	31.0	194.5
112	250	180	18	5.0	215	M12	30	28	60	8	31.0	194.5
132	300	230	18	5.0	265	M12	45	38	80	10	41.0	270.5
160	350	250	25	6.0	300	M16	66	42	110	12	45.0	315.5
180	350	250	25	6.0	300	M16	59	48	110	14	51.5	315.5
200	400	300	20	6.0	350	M16x29	60	55	110	16	59.0	360.5
225	450	350	50	6.0	400	M16x29	84 (36)	60 (55)	140 (110)	18 (16)	64.0 (59.0)	414.0
250	550	450	27	6.0	500	M16	75	65	140	18	69	445.5
K...169												
100	250	180	18	5.0	215	M12	30	28	60	8	31.0	193.0
112	250	180	18	5.0	215	M12	30	28	60	8	31.0	193.0
132	300	230	18	5.0	265	M12	45	38	80	10	41.0	264.0
160	350	250	25	6.0	300	M16	66	42	110	12	45.0	309.0
180	350	250	25	6.0	300	M16	59	48	110	14	51.5	309.0
200	400	300	20	6.0	350	M16x29	60	55	110	16	59.0	354.0
225	450	350	50	6.0	400	M16x29	84 (36)	60 (55)	140 (110)	18 (16)	64.0 (59.0)	401.5
250	550	450	27	6.0	500	M16	75	65	140	18	69.0	439.0
280	550	450	27	6.0	500	M16	51	75 (65)	140	20 (18)	79.5 (69)	314.5
K...189												
112	250	180	18	5.0	215	M12	30	28	60	8	31.0	180.5
132	300	230	18	5.0	265	M12	45	38	80	10	41.0	251.0
160	350	250	25	6.0	300	M16	66	42	110	12	45.0	296.0
180	350	250	25	6.0	300	M16	59	48	110	14	51.5	296.0
200	400	300	20	6.0	350	M16x29	60	55	110	16	59.0	340.5
225	450	350	50	6.0	400	M16x29	84 (36)	60 (55)	140 (110)	18 (16)	64.0 (59.0)	387.0
250	550	450	27	6.0	500	M16	75	65	140	18	69	420.5
280	550	450	27	6.0	500	M16	51	75 (65)	140	20 (18)	79.5 (69.0)	297.5
315	660	550	33	8.0	600	m20	33.5	80 (65)	170 (140)	22 (18)	85.0 (69.0)	321.5

SIMOGEAR Gearboxes

Bevel gearbox in a foot-mounted design

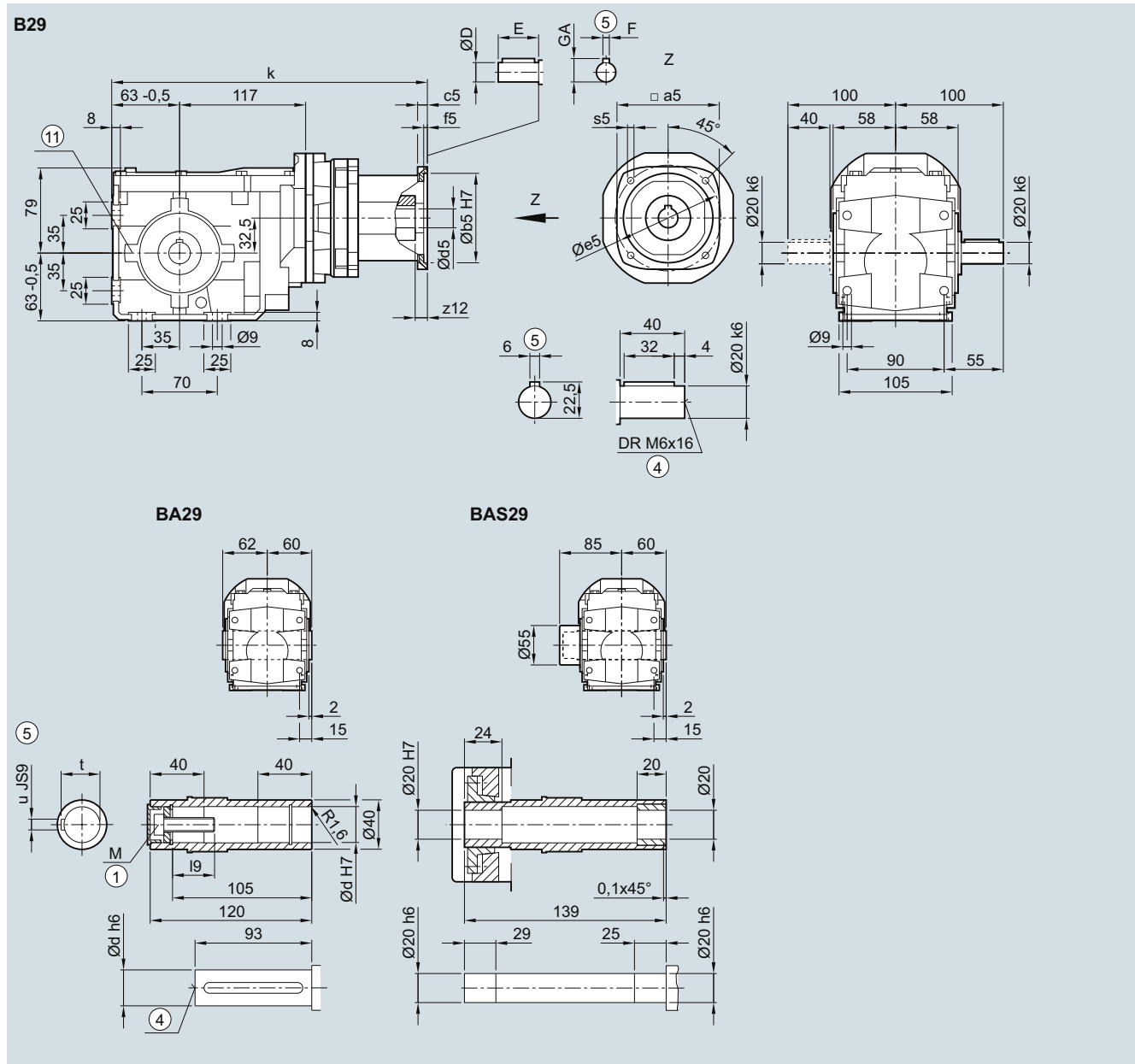
Dimensions**B..29 gearbox in a foot-mounted design****B030KQ, BA030KQ, BAS030KQ**

Shaft	d	l9	M	t	u							
	20	23.4	M6	22.8	6							
	25	27.6	M10	28.3	8							
Adapter	a5	b5	c5	f5	e5	s5	z12	d5/D	E	F	GA	k
703	71.6	60	9	4.0	75	M5	18	14	30	5	16.0	279.5
704	96.5	80	10	4.0	100	M6	14	19	40	6	21.5	326.5
706	126.0	110	12	4.5	130	M8	15	24	50	8	27.0	339.5

① ISO 4014

④ DIN 332

⑤ Feather key/keyway DIN 6885

⑩ Use bores only for housing flange design

B.F.29 gearbox in a flange-mounted design

BF030KQ, BAF030KQ, BAFS030KQ

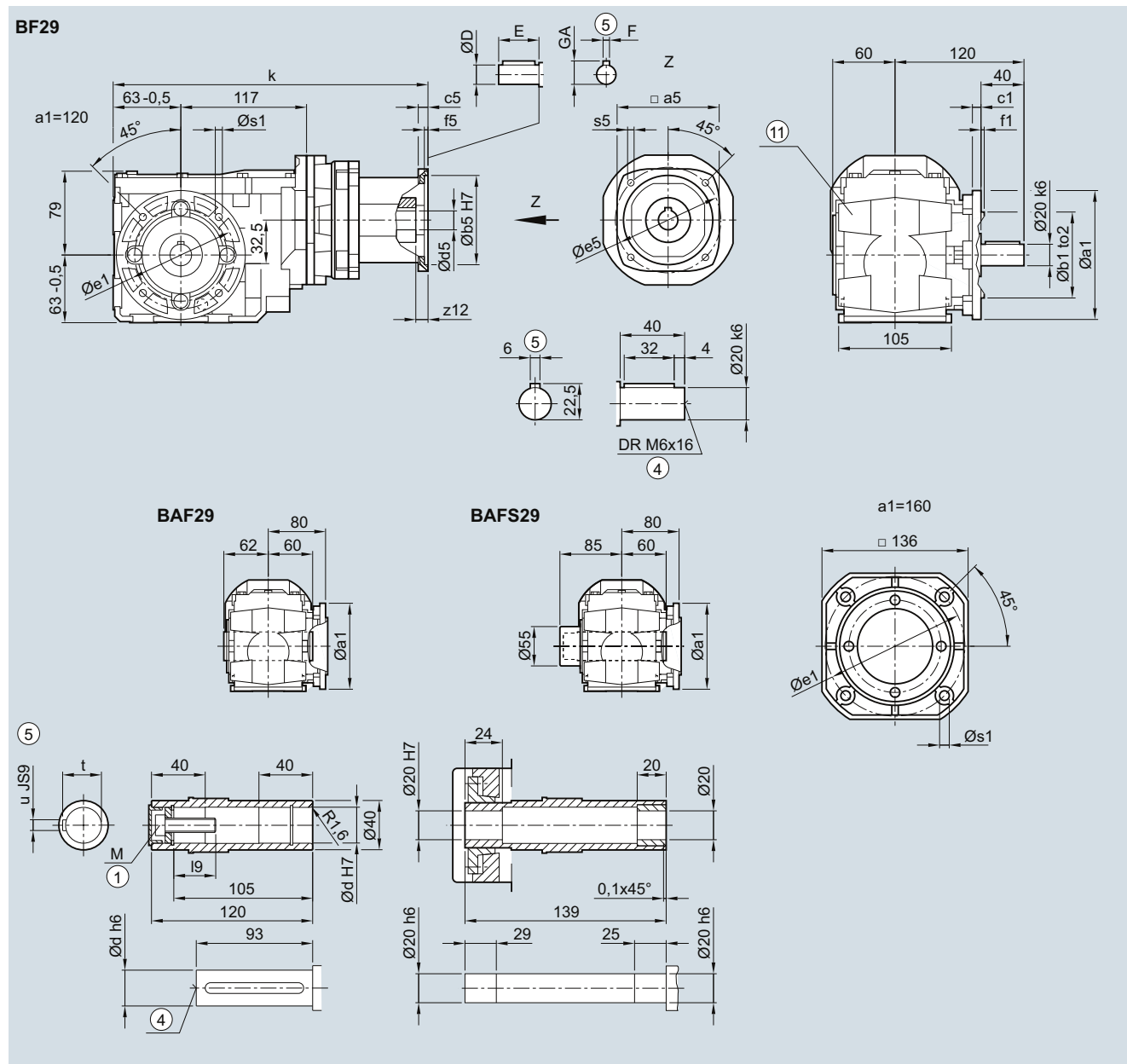

Flange	a1	b1	to2	c1	e1	f1	s1					
	120	80	j6	8	100	3.0	6.6					
	160	110	j6	9	130	3.5	9.0					
Shaft	d	l9	M	t	u							
	20	23.4	M6	22.8	6							
	25	27.6	M10	28.3	8							
Adapter	a5	b5	c5	f5	e5	s5	z12	d5/D	E	F	GA	k
703	71.6	60	9	4.0	75	M5	18	14	30	5	16.0	279.5
704	96.5	80	10	4.0	100	M6	14	19	40	6	21.5	326.5
706	126.0	110	12	4.5	130	M8	15	24	50	8	27.0	339.5

① ISO 4014

④ DIN 332

⑤ Feather key/keyway DIN 6885

⑩ Use bores only for foot-mounted design

SIMOGEAR Gearboxes

Bevel gearbox with adapter KQ

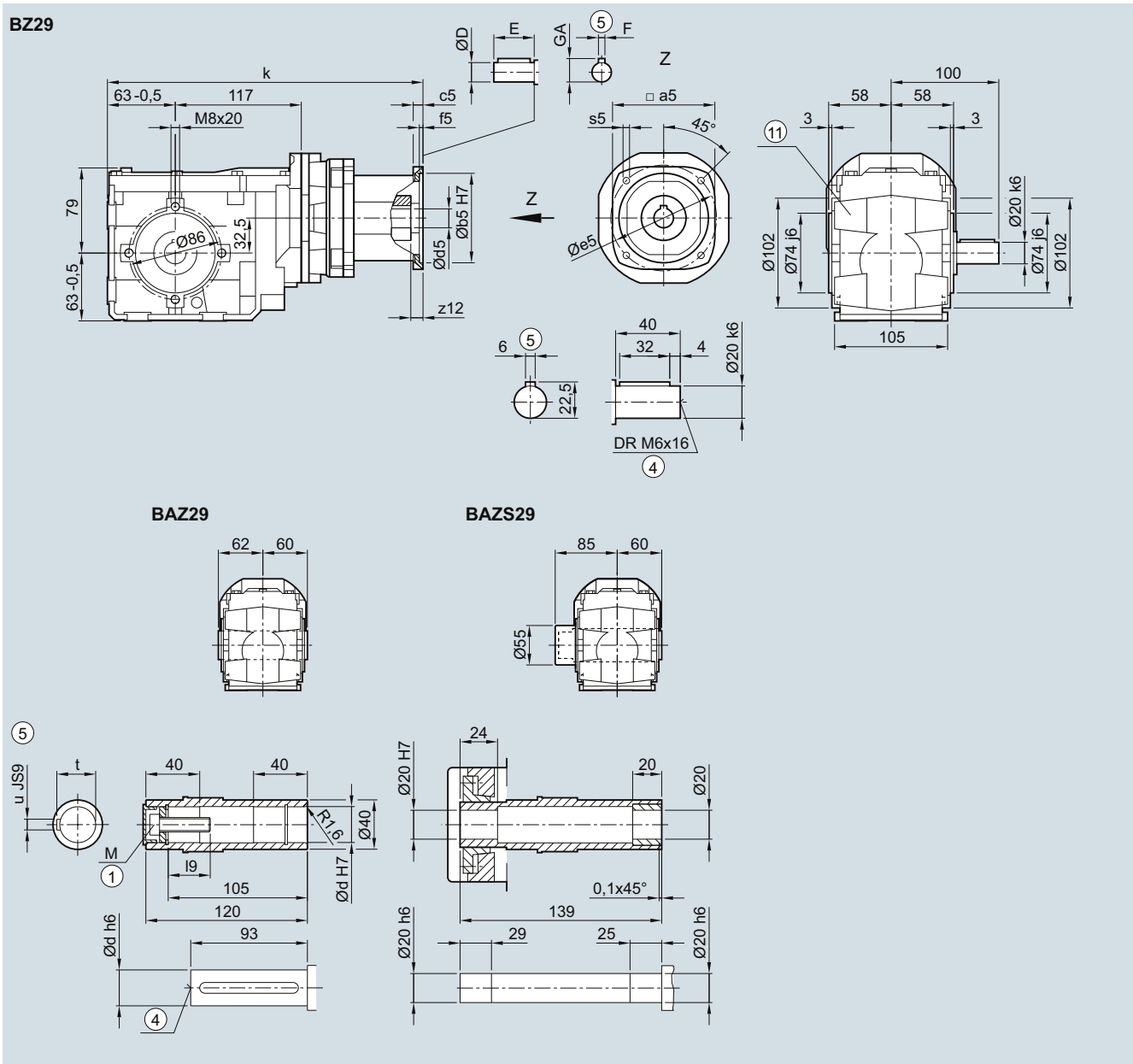
Dimensions**B.Z.29 gearbox in a housing flange design****BZ030KQ, BAZ030KQ, BAZS030KQ**

Shaft	d	l9	M	t	u
	20	23.4	M6	22.8	6
	25	27.6	M10	28.3	8

Adapter	a5	b5	c5	f5	e5	s5	z12	d5/D	E	F	GA	k
703	71.6	60	9	4.0	75	M5	18	14	30	5	16.0	279.5
704	96.5	80	10	4.0	100	M6	14	19	40	6	21.5	326.5
706	126.0	110	12	4.5	130	M8	15	24	50	8	27.0	339.5

① ISO 4014

④ DIN 332

⑤ Feather key/keyway DIN 6885

⑪ Use bores only for foot-mounted design

BAD.29 gearbox in a shaft-mounted design

BAD030KQ, BADS030KQ

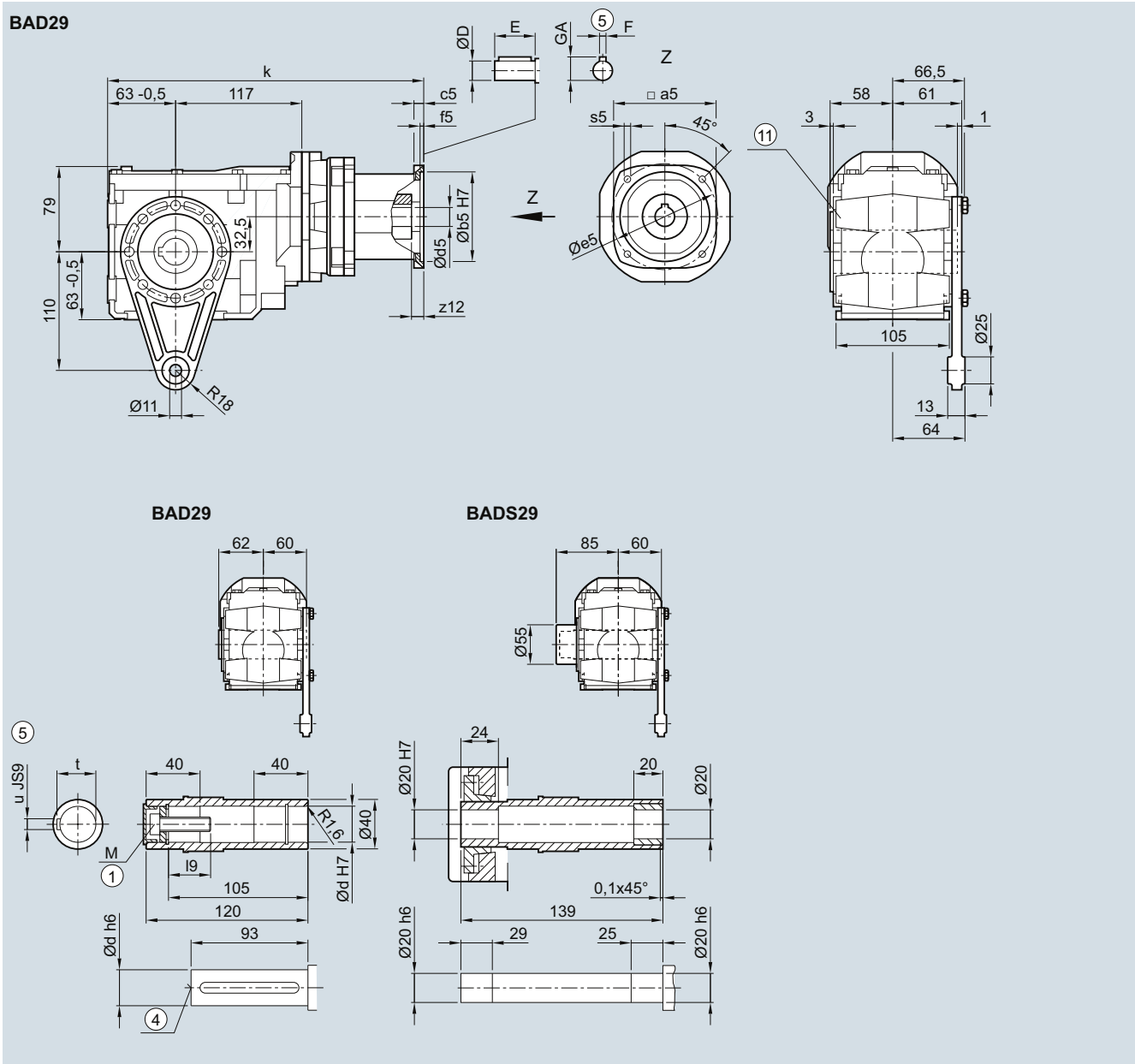

5

Shaft	d	l9	M	t	u
	20	23.4	M6	22.8	6
	25	27.6	M10	28.3	8

Adapter	a5	b5	c5	f5	e5	s5	z12	d5/D	E	F	GA	k
703	71.6	60	9	4.0	75	M5	18	14	30	5	16.0	279.5
704	96.5	80	10	4.0	100	M6	14	19	40	6	21.5	326.5
706	126.0	110	12	4.5	130	M8	15	24	50	8	27.0	339.5

① ISO 4014

④ DIN 332

⑤ Feather key/keyway DIN 6885

⑩ Use bores only for foot-mounted design

SIMOGEAR Gearboxes

Bevel gearbox with adapter KQ

Dimensions

B..39 gearbox in a foot-mounted design

B030KQ, BA030KQ, BAS030KQ

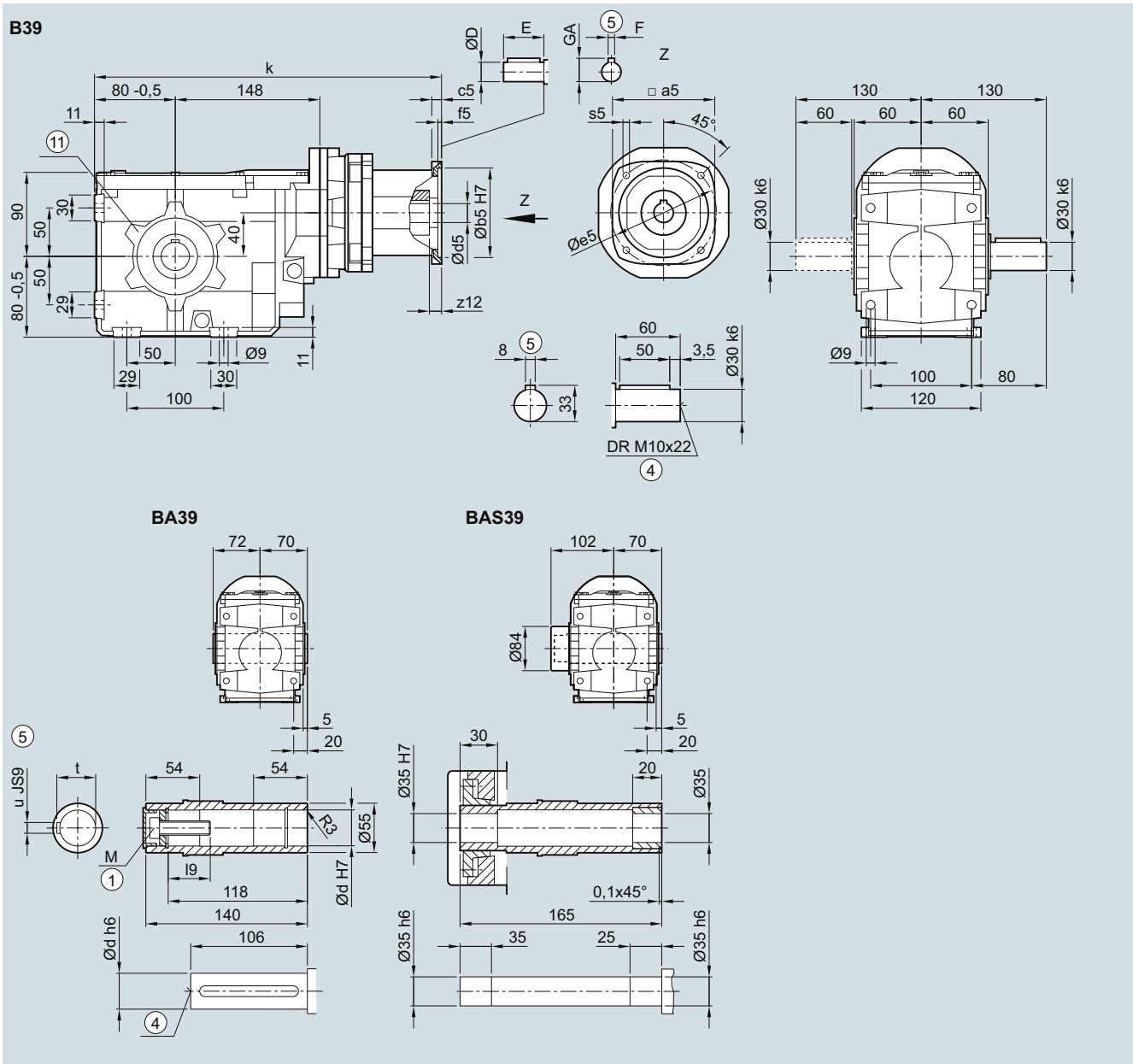

Adapter	a5	b5	c5	f5	e5	s5	z12	d5/D	E	F	GA	k
703	71.6	60	9	4.0	75	M5	18.0	14	30	5	16.0	327.5
704	96.5	80	10	4.0	100	M6	14.0	19	40	6	21.5	374.5
706	126.0	110	12	4.5	130	M8	15.0	24	50	8	27.0	387.5
708	155.0	130	15	4.5	165	M10	23.5	32	58	10	35.0	431.0

① ISO 4014

④ DIN 332

⑤ Feather key/keyway DIN 6885

⑩ Use bores only for housing flange design

B.F.39 gearbox in a flange-mounted design

BF030KQ, BAF030KQ, BAFS030KQ

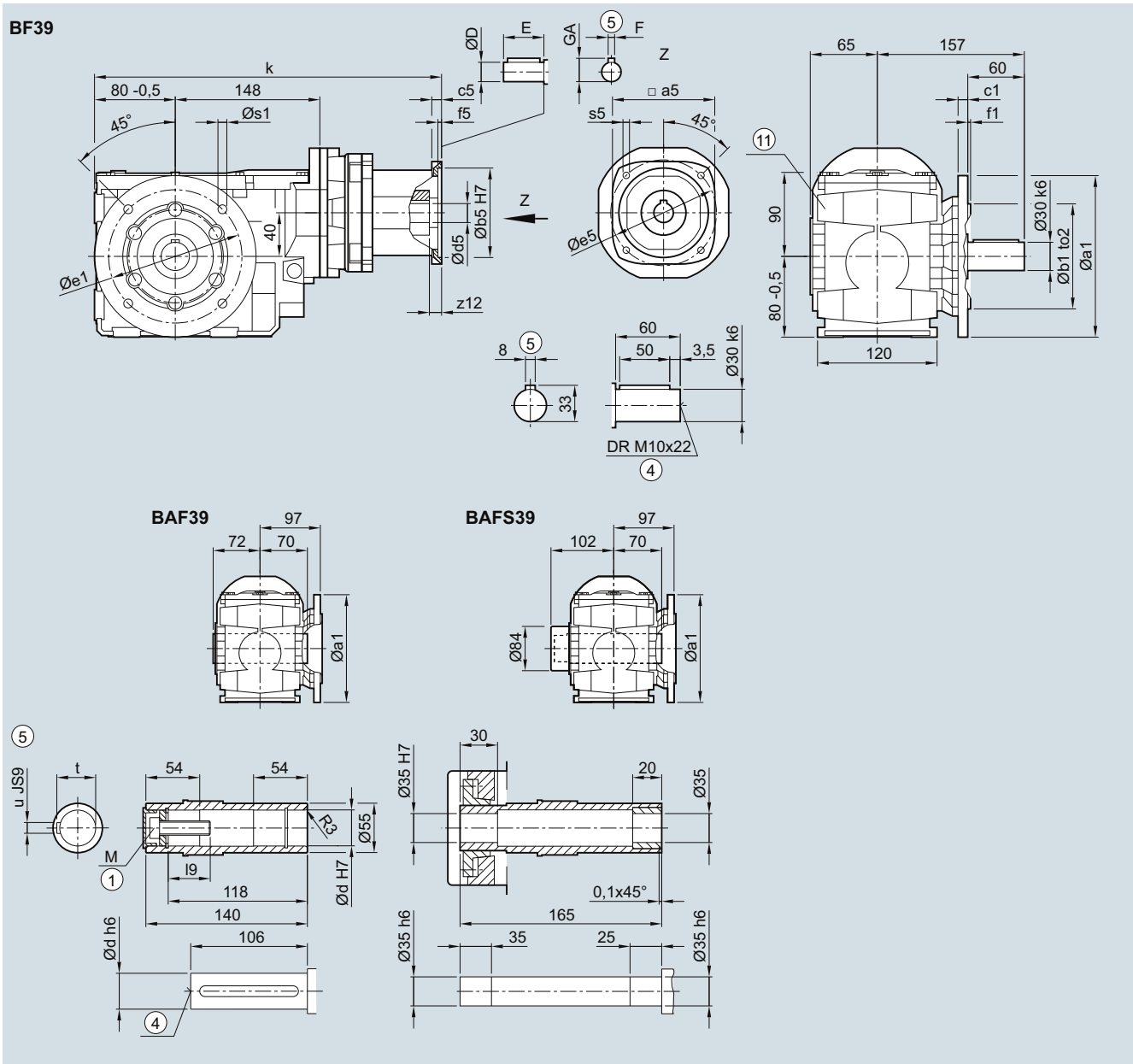

Flange	a1	b1	to2	c1	e1	f1	s1					
	160	110	j6	10	130	3.5	11.0					
	200	130	j6	12	165	3.5	11.0					
Shaft	d	l9	M	t	u							
	30	32.6	M10	33.3	8							
	35	37.0	M12	38.3	10							
	40	47.75	M16	43.3	12							
Adapter	a5	b5	c5	f5	e5	s5	z12	d5/D	E	F	GA	k
703	71.6	60	9	4.0	75	M5	18.0	14	30	5	16.0	327.5
704	96.5	80	10	4.0	100	M6	14.0	19	40	6	21.5	374.5
706	126.0	110	12	4.5	130	M8	15.0	24	50	8	27.0	387.5
708	155.0	130	15	4.5	165	M10	23.5	32	58	10	35.0	431.0

① ISO 4014

④ DIN 332

⑤ Feather key/keyway DIN 6885

⑩ Use bores only for foot-mounted design

SIMOGEAR Gearboxes

Bevel gearbox with adapter KQ

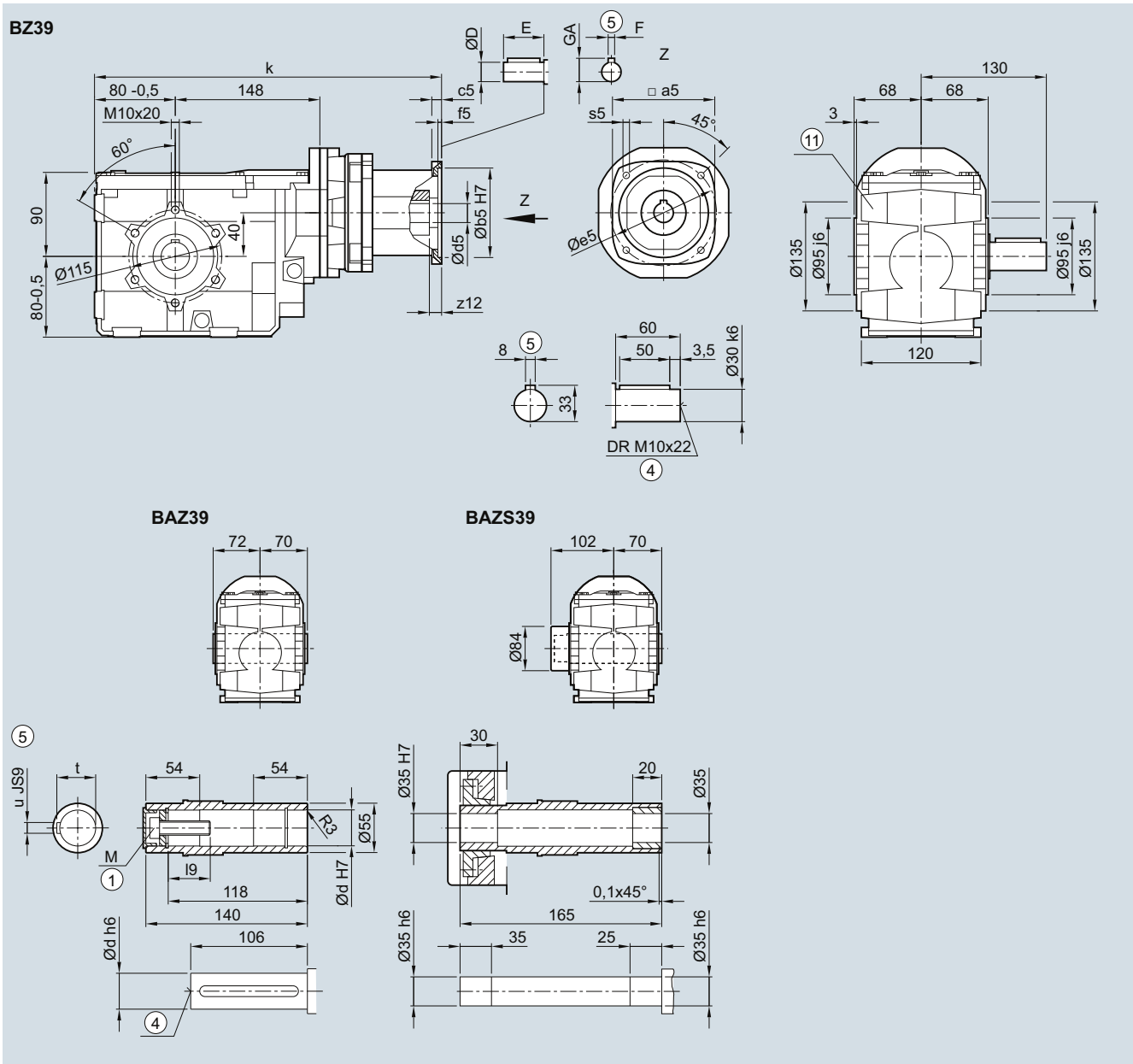
Dimensions**B.Z.39 in a housing flange design****BZ030KQ, BAZ030KQ, BAZS030KQ**

Adapter	a5	b5	c5	f5	e5	s5	z12	d5/D	E	F	GA	k
703	71.6	60	9	4.0	75	M5	18.0	14	30	5	16.0	327.5
704	96.5	80	10	4.0	100	M6	14.0	19	40	6	21.5	374.5
706	126.0	110	12	4.5	130	M8	15.0	24	50	8	27.0	387.5
708	155.0	130	15	4.5	165	M10	23.5	32	58	10	35.0	431.0

① ISO 4014

④ DIN 332

⑤ Feather key/keyway DIN 6885

⑩ Use bores only for foot-mounted design

BAD.39 gearbox in a shaft-mounted design

BAD030KQ, BADS030KQ

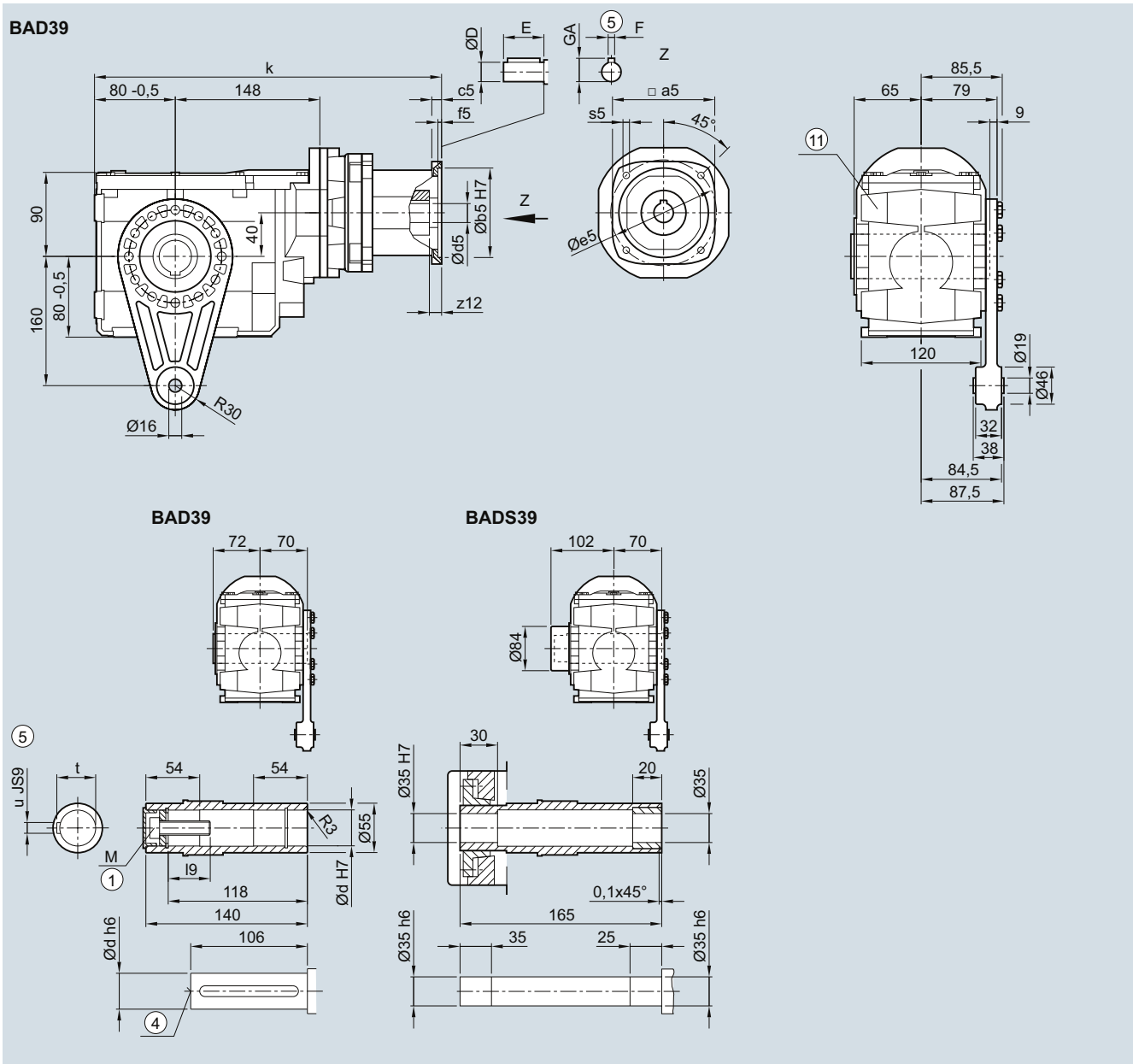

5

Adapter	a5	b5	c5	f5	e5	s5	z12	d5/D	E	F	GA	k
703	71.6	60	9	4.0	75	M5	18.0	14	30	5	16.0	327.5
704	96.5	80	10	4.0	100	M6	14.0	19	40	6	21.5	374.5
706	126.0	110	12	4.5	130	M8	15.0	24	50	8	27.0	387.5
708	155.0	130	15	4.5	165	M10	23.5	32	58	10	35.0	431.0

① ISO 4014

④ DIN 332

⑤ Feather key/keyway DIN 6885

⑩ Use bores only for foot-mounted design

SIMOGEAR Gearboxes

Bevel gearbox with adapter KQ

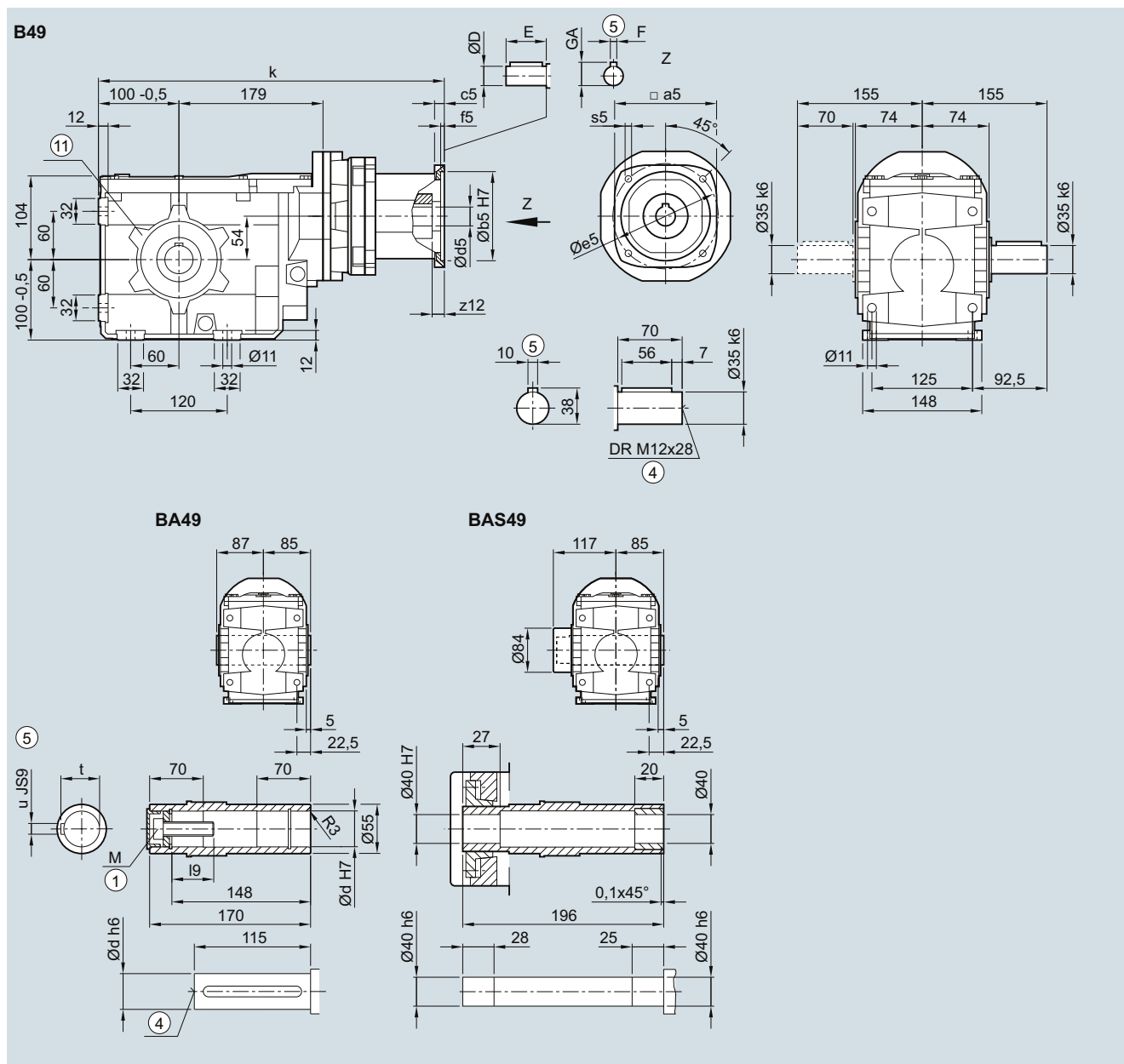
Dimensions**B..49 gearbox in a foot-mounted design****B030KQ, BA030KQ, BAS030KQ**

Adapter	a5	b5	c5	f5	e5	s5	z12	d5/D	E	F	GA	k
703	71.6	60	9	4.0	75	M5	18.0	14	30	5	16.0	369.0
704	96.5	80	10	4.0	100	M6	14.0	19	40	6	21.5	416.0
706	126.0	110	12	4.5	130	M8	15.0	24	50	8	27.0	429.0
708	155.0	130	15	4.5	165	M10	23.5	32	58	10	35.0	472.5
710	192.5	180	15	5.0	215	M12	33.0	38	80	10	41.0	541.5

① ISO 4014

④ DIN 332

⑤ Feather key/keyway DIN 6885

⑩ Use bores only for housing flange design

B.F.49 gearbox in a flange-mounted design

BF030KQ, BAF030KQ, BAFS030KQ

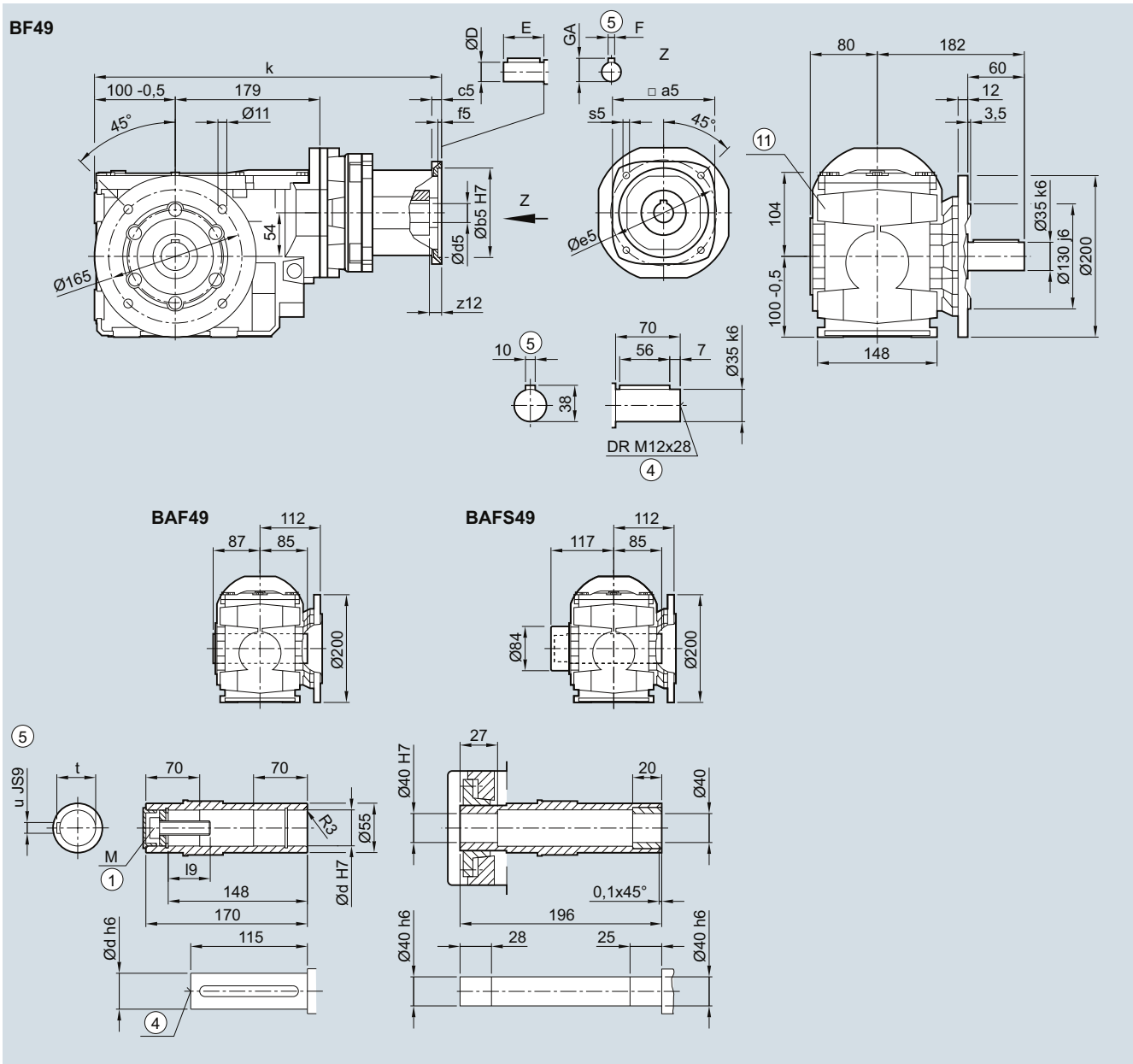

Adapter	a5	b5	c5	f5	e5	s5	z12	d5/D	E	F	GA	k
703	71.6	60	9	4.0	75	M5	18.0	14	30	5	16.0	369.0
704	96.5	80	10	4.0	100	M6	14.0	19	40	6	21.5	416.0
706	126.0	110	12	4.5	130	M8	15.0	24	50	8	27.0	429.0
708	155.0	130	15	4.5	165	M10	23.5	32	58	10	35.0	472.5
710	192.5	180	15	5.0	215	M12	33.0	38	80	10	41.0	541.5

① ISO 4014

④ DIN 332

⑤ Feather key/keyway DIN 6885

⑪ Use bores only for foot-mounted design

SIMOGEAR Gearboxes

Bevel gearbox with adapter KQ

Dimensions

B.Z.49 in a housing flange design

BZ030KQ, BAZ030KQ, BAZS030KQ

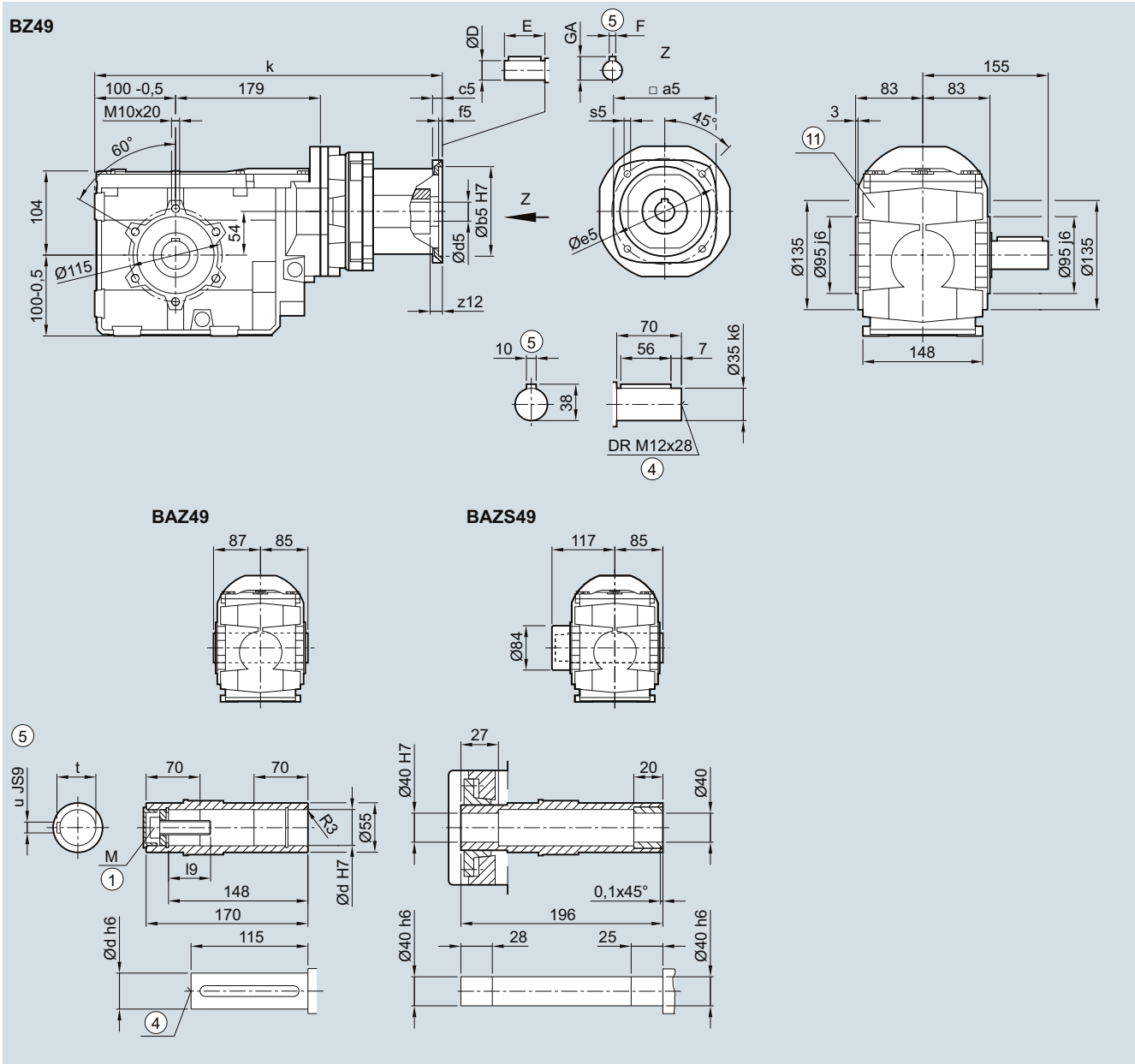

Adapter	a5	b5	c5	f5	e5	s5	z12	d5/D	E	F	GA	k
703	71.6	60	9	4.0	75	M5	18.0	14	30	5	16.0	369.0
704	96.5	80	10	4.0	100	M6	14.0	19	40	6	21.5	416.0
706	126.0	110	12	4.5	130	M8	15.0	24	50	8	27.0	429.0
708	155.0	130	15	4.5	165	M10	23.5	32	58	10	35.0	472.5
710	192.5	180	15	5.0	215	M12	33.0	38	80	10	41.0	541.5

① ISO 4014

④ DIN 332

⑤ Feather key/keyway DIN 6885

⑪ Use bores only for foot-mounted design

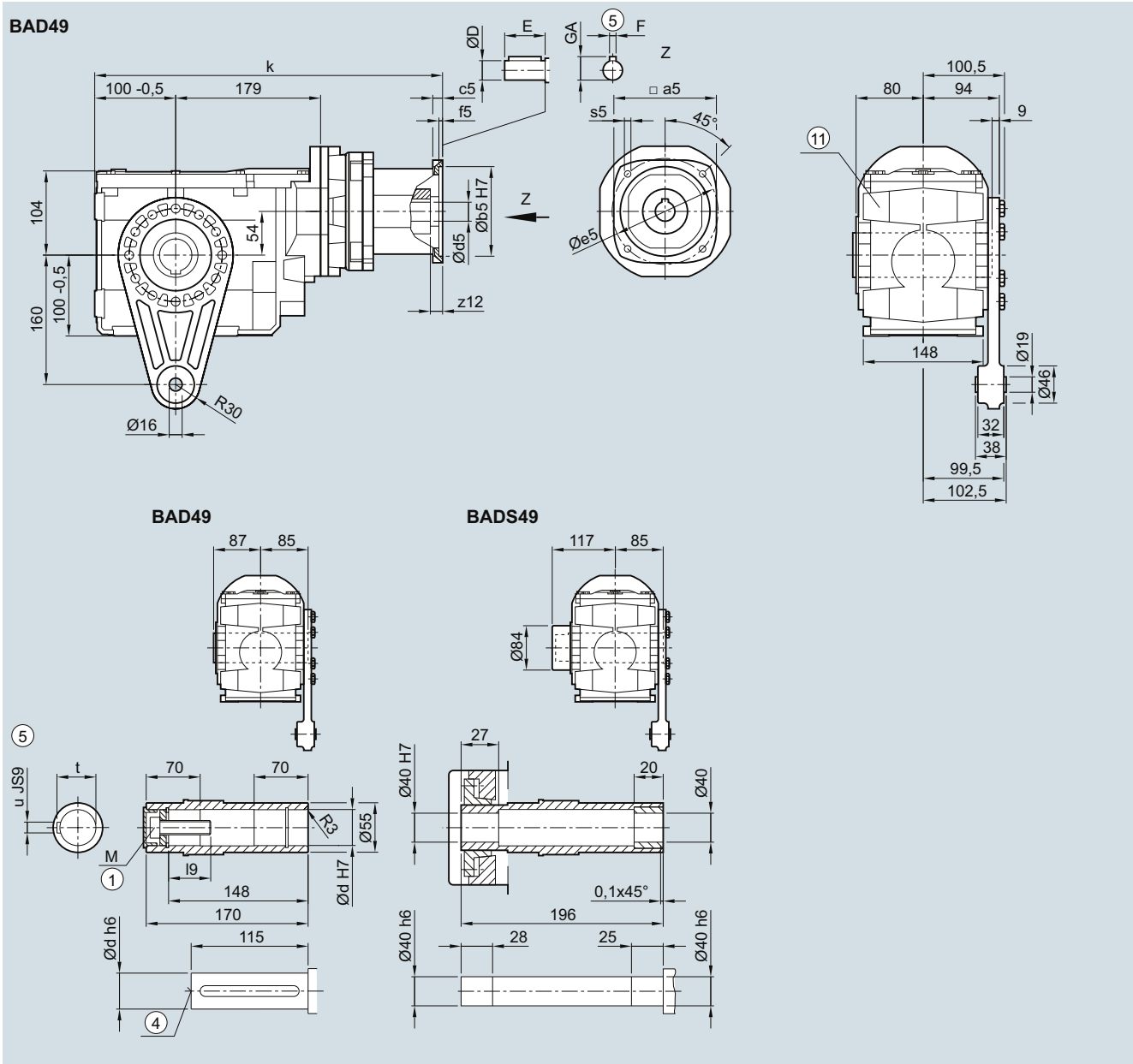
BAD.49 gearbox in a shaft-mounted design
BAD030KQ, BADS030KQ

Adapter	a5	b5	c5	f5	e5	s5	z12	d5/D	E	F	GA	k
703	71.6	60	9	4.0	75	M5	18.0	14	30	5	16.0	369.0
704	96.5	80	10	4.0	100	M6	14.0	19	40	6	21.5	416.0
706	126.0	110	12	4.5	130	M8	15.0	24	50	8	27.0	429.0
708	155.0	130	15	4.5	165	M10	23.5	32	58	10	35.0	472.5
710	192.5	180	15	5.0	215	M12	33.0	38	80	10	41.0	541.5

① ISO 4014

④ DIN 332

⑤ Feather key/keyway DIN 6885

⑩ Use bores only for foot-mounted design

SIMOGEAR Gearboxes

Bevel gearbox with adapter KQ

Dimensions

K.39 gearbox in a foot-mounted design

K030KQ, KA030KQ, KAS030KQ, KAT030KQ

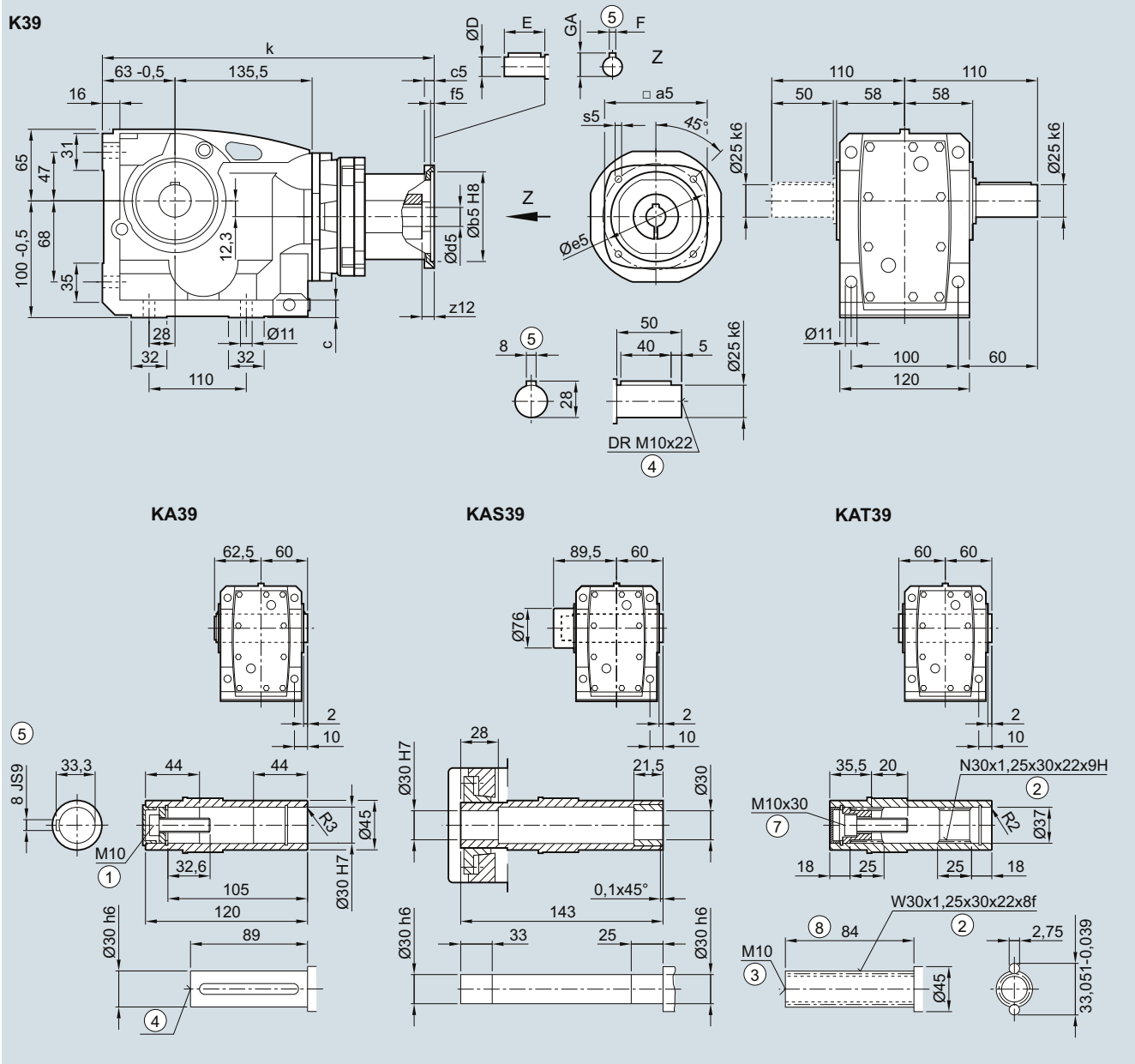

Adapter	a5	b5	c5	f5	e5	s5	z12	d5/D	E	F	GA	k
703	71.6	60	9	4.0	75	M5	18.0	14	30	5	16.0	297.5
704	96.5	80	10	4.0	100	M6	14.0	19	40	6	21.5	344.5
706	126.0	110	12	4.5	130	M8	15.0	24	50	8	27.0	357.5
708	155.0	130	15	4.5	165	M10	23.5	32	58	10	35.0	401.0

① ISO 4014 ② DIN 5480 ③ DIN 332-D ④ DIN 332 ⑤ Feather key/keyway DIN 6885 ⑦ ISO 4762 ⑧ Without locating shoulder +1 mm

K.F.39 gearbox in a flange-mounted design

KF030KQ, KAF030KQ, KAFS030KQ, KAFT030KQ

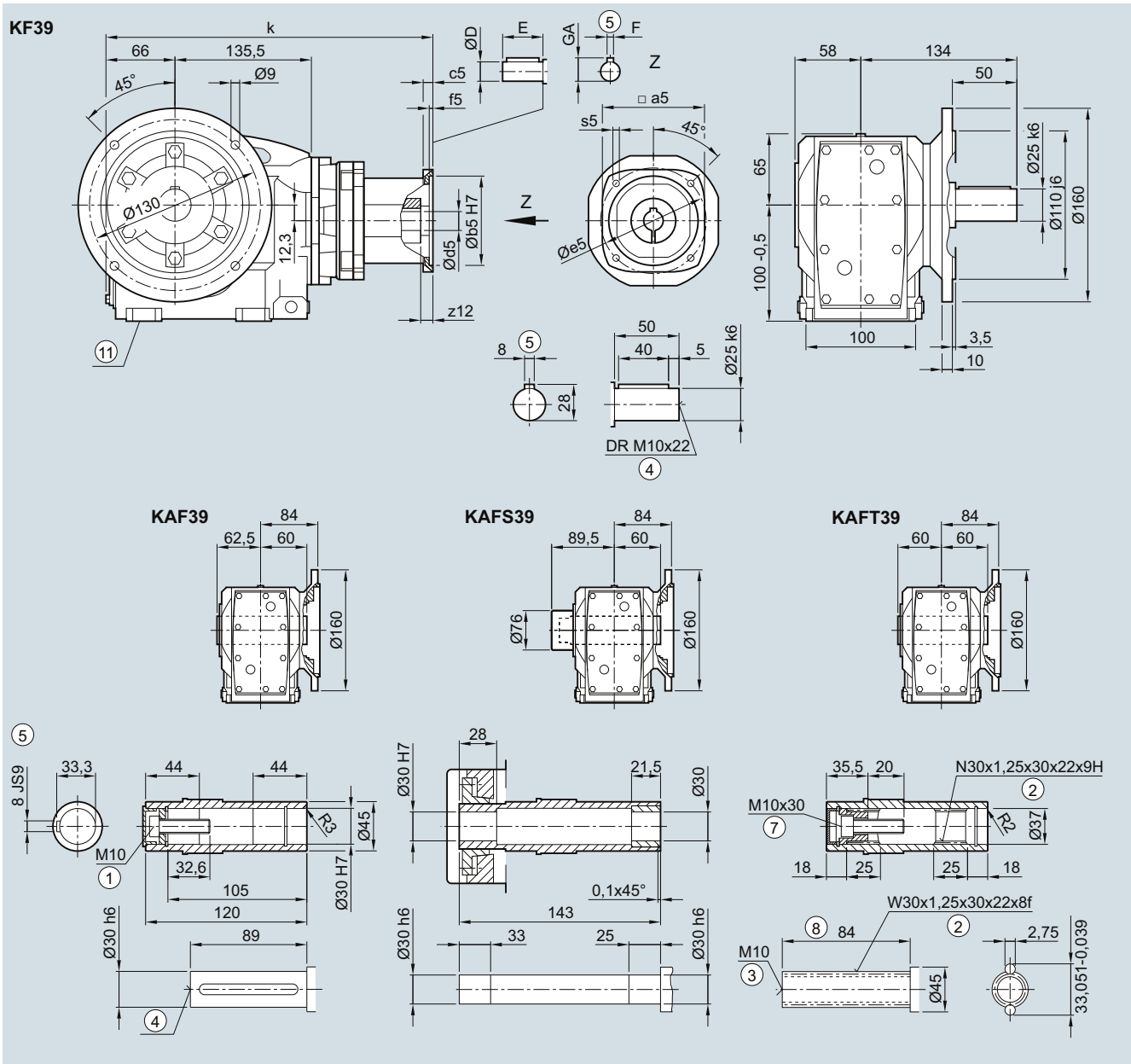

Adapter	a5	b5	c5	f5	e5	s5	z12	d5/D	E	F	GA	k
703	71.6	60	9	4.0	75	M5	18.0	14	30	5	16.0	300.5
704	96.5	80	10	4.0	100	M6	14.0	19	40	6	21.5	347.5
706	126.0	110	12	4.5	130	M8	15.0	24	50	8	27.0	360.5
708	155.0	130	15	4.5	165	M10	23.5	32	58	10	35.0	404.0

① ISO 4014 ② DIN 5480 ③ DIN 332-D ④ DIN 332 ⑤ Feather key/keyway DIN 6885
 ⑦ ISO 4762 ⑧ Without locating shoulder +1 mm ⑥ Use bores only for foot-mounted design

SIMOGEAR Gearboxes

Bevel gearbox with adapter KQ

Dimensions

K.Z.39 gearbox in a housing flange design

KZ030KQ, KAZ030KQ, KAZS030KQ, KAZT030KQ

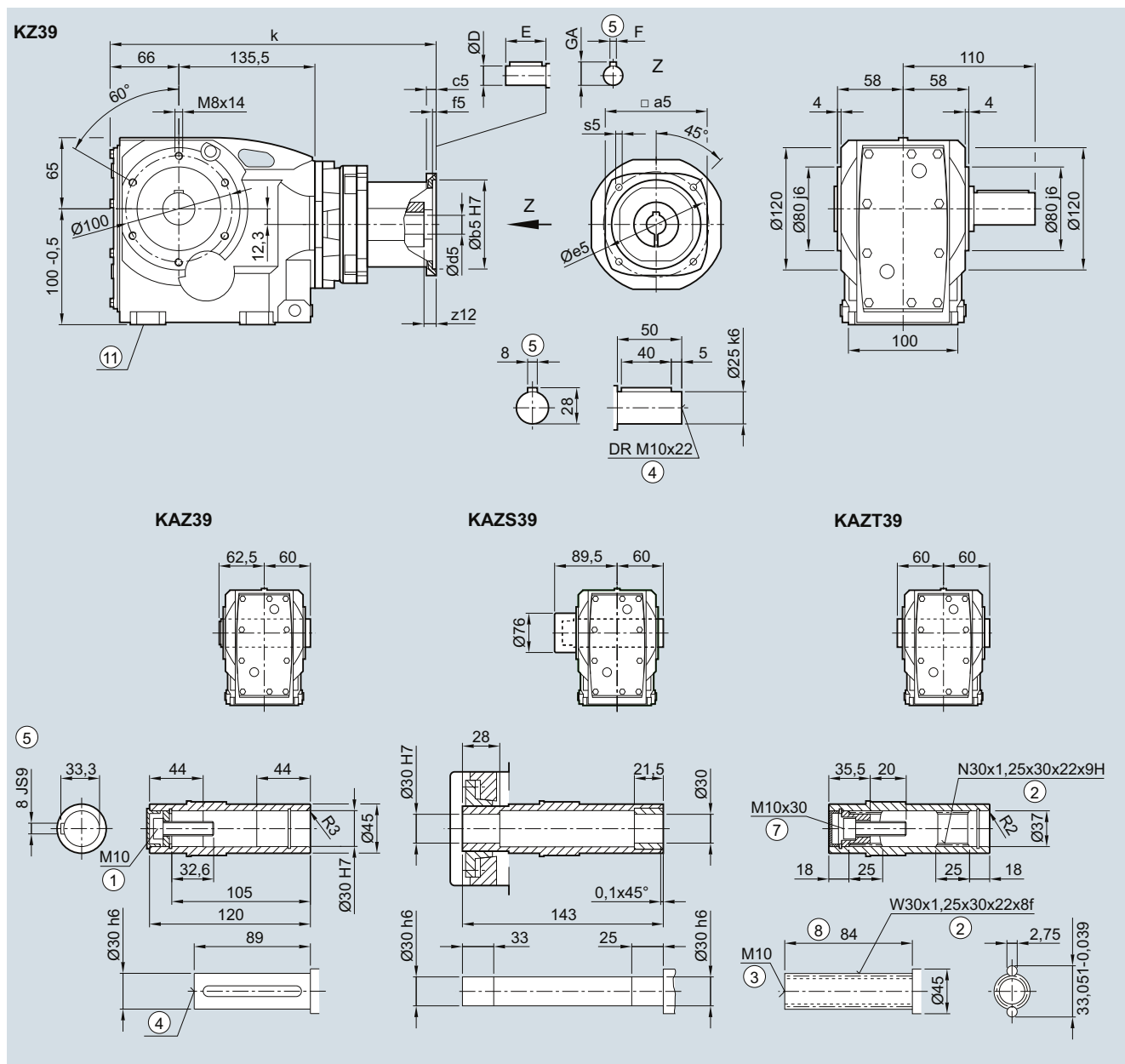

Adapter	a5	b5	c5	f5	e5	s5	z12	d5/D	E	F	GA	k
703	71.6	60	9	4.0	75	M5	18.0	14	30	5	16.0	300.5
704	96.5	80	10	4.0	100	M6	14.0	19	40	6	21.5	347.5
706	126.0	110	12	4.5	130	M8	15.0	24	50	8	27.0	360.5
708	155.0	130	15	4.5	165	M10	23.5	32	58	10	35.0	404.0

- ① ISO 4014 ② DIN 5480 ③ DIN 332-D ④ DIN 332 ⑤ Feather key/keyway DIN 6885
- ⑦ ISO 4762 ⑧ Without locating shoulder +1 mm ⑨ Use bores only for foot-mounted design

KAD.39 gearbox in a shaft-mounted design

KAD030KQ, KADS030KQ, KADT030KQ

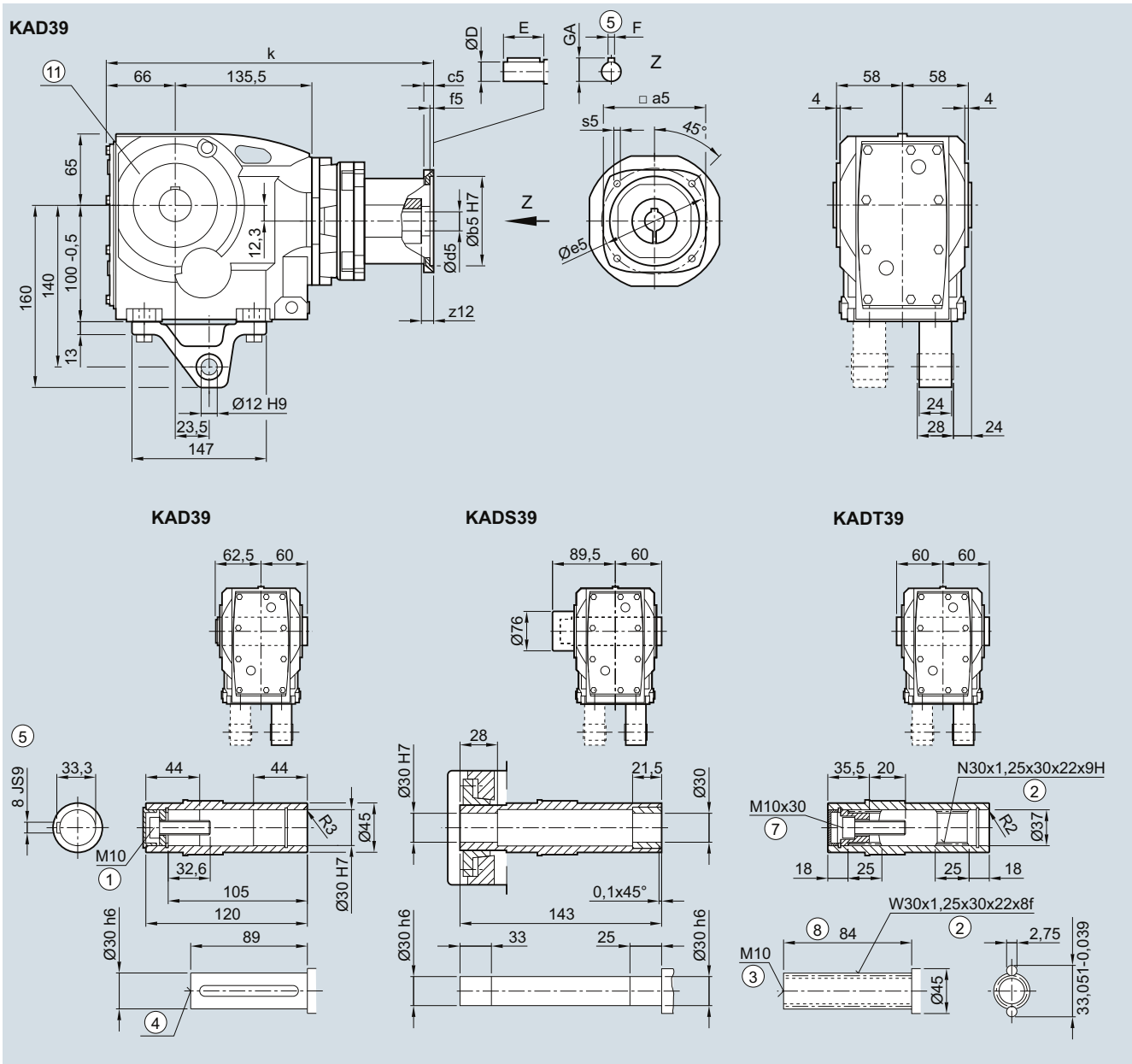

Adapter	a5	b5	c5	f5	e5	s5	z12	d5/D	E	F	GA	k
703	71.6	60	9	4.0	75	M5	18.0	14	30	5	16.0	300.5
704	96.5	80	10	4.0	100	M6	14.0	19	40	6	21.5	347.5
706	126.0	110	12	4.5	130	M8	15.0	24	50	8	27.0	360.5
708	155.0	130	15	4.5	165	M10	23.5	32	58	10	35.0	404.0

① ISO 4014 ② DIN 5480 ③ DIN 332-D ④ DIN 332 ⑤ Feather key/keyway DIN 6885
 ⑦ ISO 4762 ⑧ Without locating shoulder +1 mm ⑩ Use bores only for housing flange design

K.F.49 gearbox in a flange-mounted design

KF030KQ, KAF030KQ, KAFS030KQ, KAFT030KQ

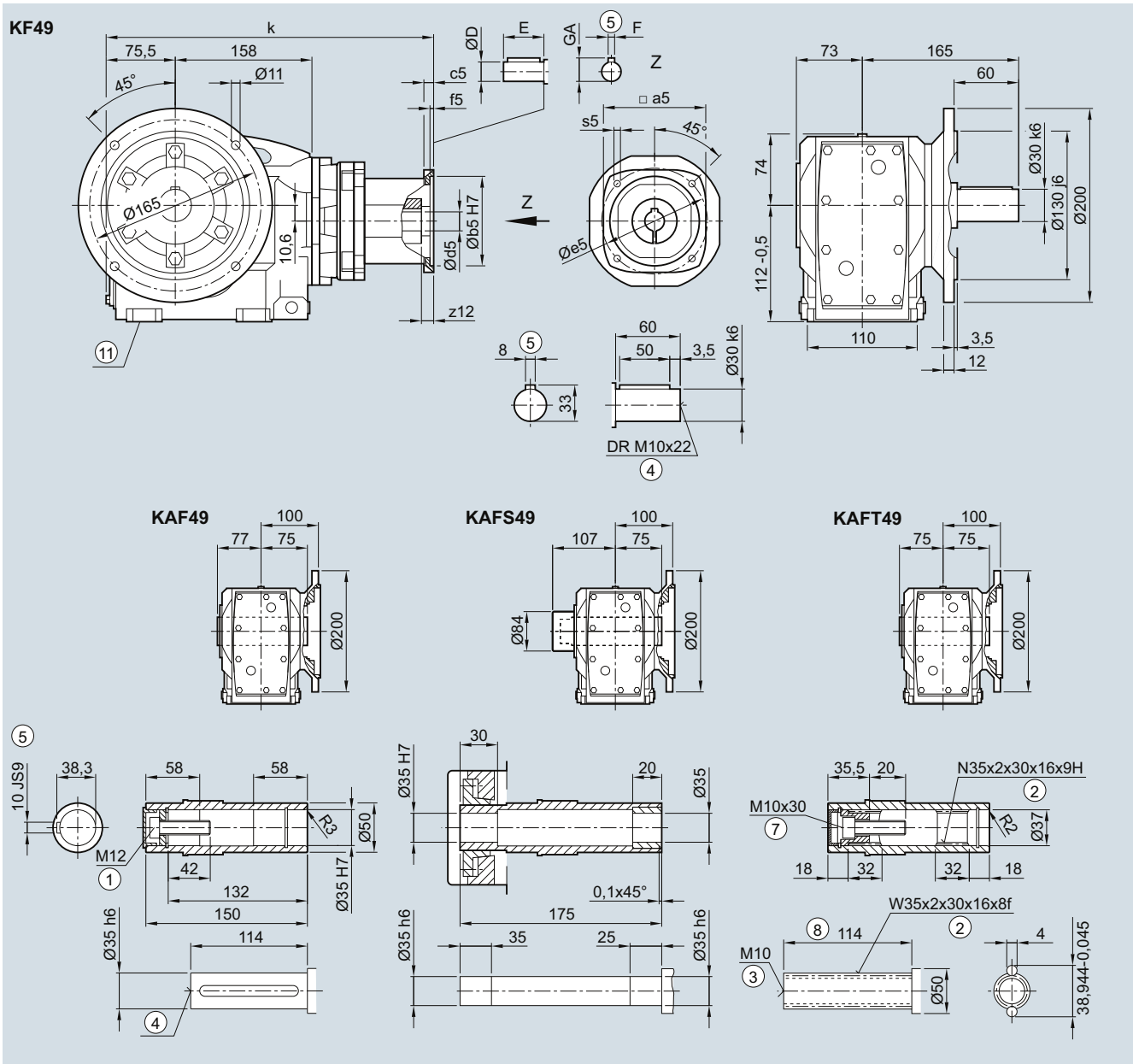

Adapter	a5	b5	c5	f5	e5	s5	z12	d5/D	E	F	GA	k
703	71.6	60	9	4.0	75	M5	18.0	14	30	5	16.0	323.5
704	96.5	80	10	4.0	100	M6	14.0	19	40	6	21.5	370.5
706	126.0	110	12	4.5	130	M8	15.0	24	50	8	27.0	383.5
708	155.0	130	15	4.5	165	M10	23.5	32	58	10	35.0	427.0
710	192.5	180	15	5.0	215	M12	33.0	38	80	10	41.0	496.0

① ISO 4014 ② DIN 5480 ③ DIN 332-D ④ DIN 332 ⑤ Feather key/keyway DIN 6885
 ⑥ ISO 4762 ⑦ Without locating shoulder +1 mm ⑧ Use bores only for foot-mounted design

SIMOGEAR Gearboxes

Bevel gearbox with adapter KQ

Dimensions

K.Z.49 in a housing flange design

KZ030KQ, KAZ030KQ, KAZS030KQ, KAZT030KQ

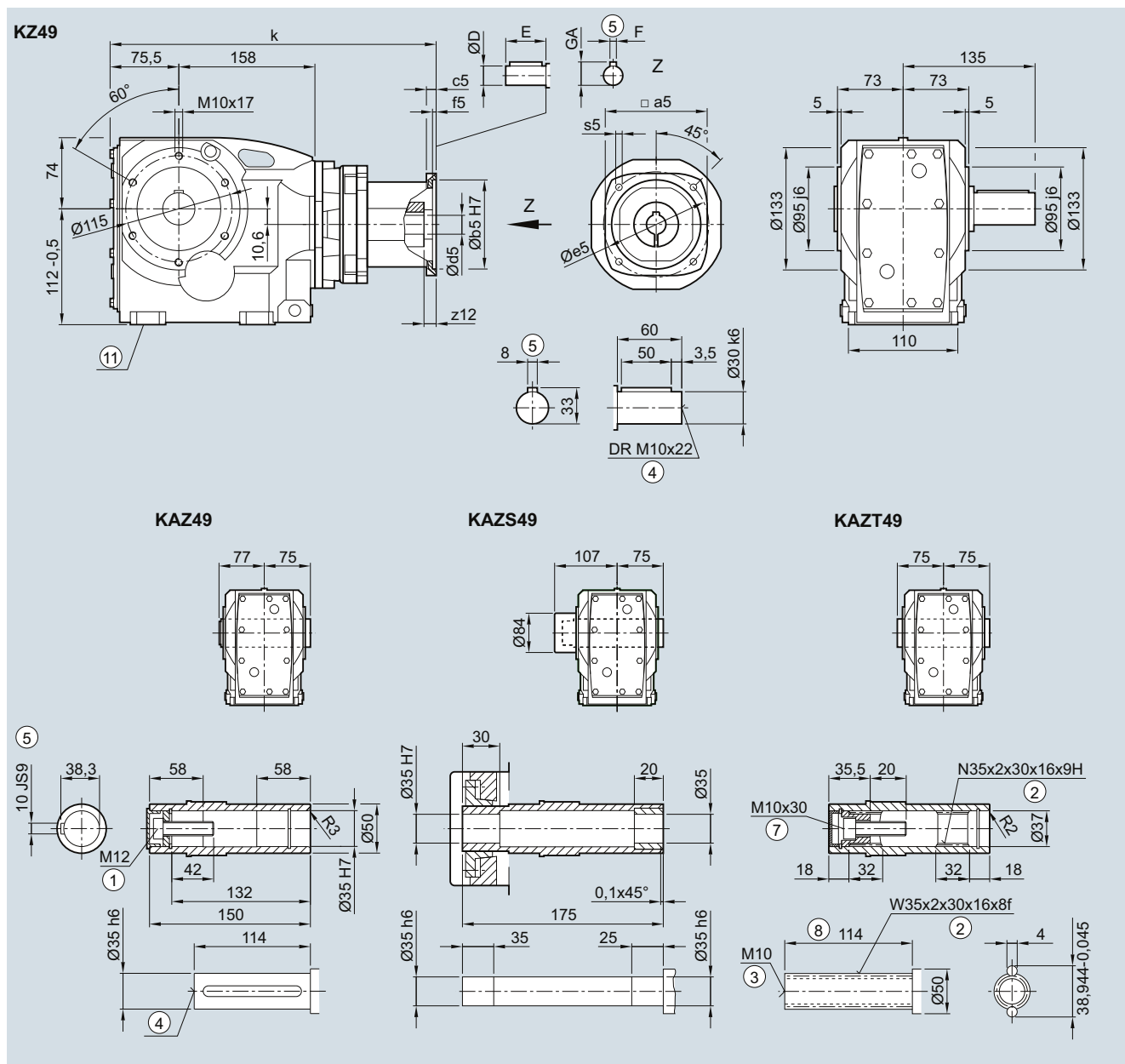

Adapter	a5	b5	c5	f5	e5	s5	z12	d5/D	E	F	GA	k
703	71.6	60	9	4.0	75	M5	18.0	14	30	5	16.0	323.5
704	96.5	80	10	4.0	100	M6	14.0	19	40	6	21.5	370.5
706	126.0	110	12	4.5	130	M8	15.0	24	50	8	27.0	383.5
708	155.0	130	15	4.5	165	M10	23.5	32	58	10	35.0	427.0
710	192.5	180	15	5.0	215	M12	33.0	38	80	10	41.0	496.0

① ISO 4014 ② DIN 5480 ③ DIN 332-D ④ DIN 332 ⑤ Feather key/keyway DIN 6885
 ⑥ ISO 4762 ⑦ Without locating shoulder +1 mm ⑧ Use bores only for foot-mounted design

KAD.49 gearbox in a shaft-mounted design

KAD030KQ, KADS030KQ, KADT030KQ

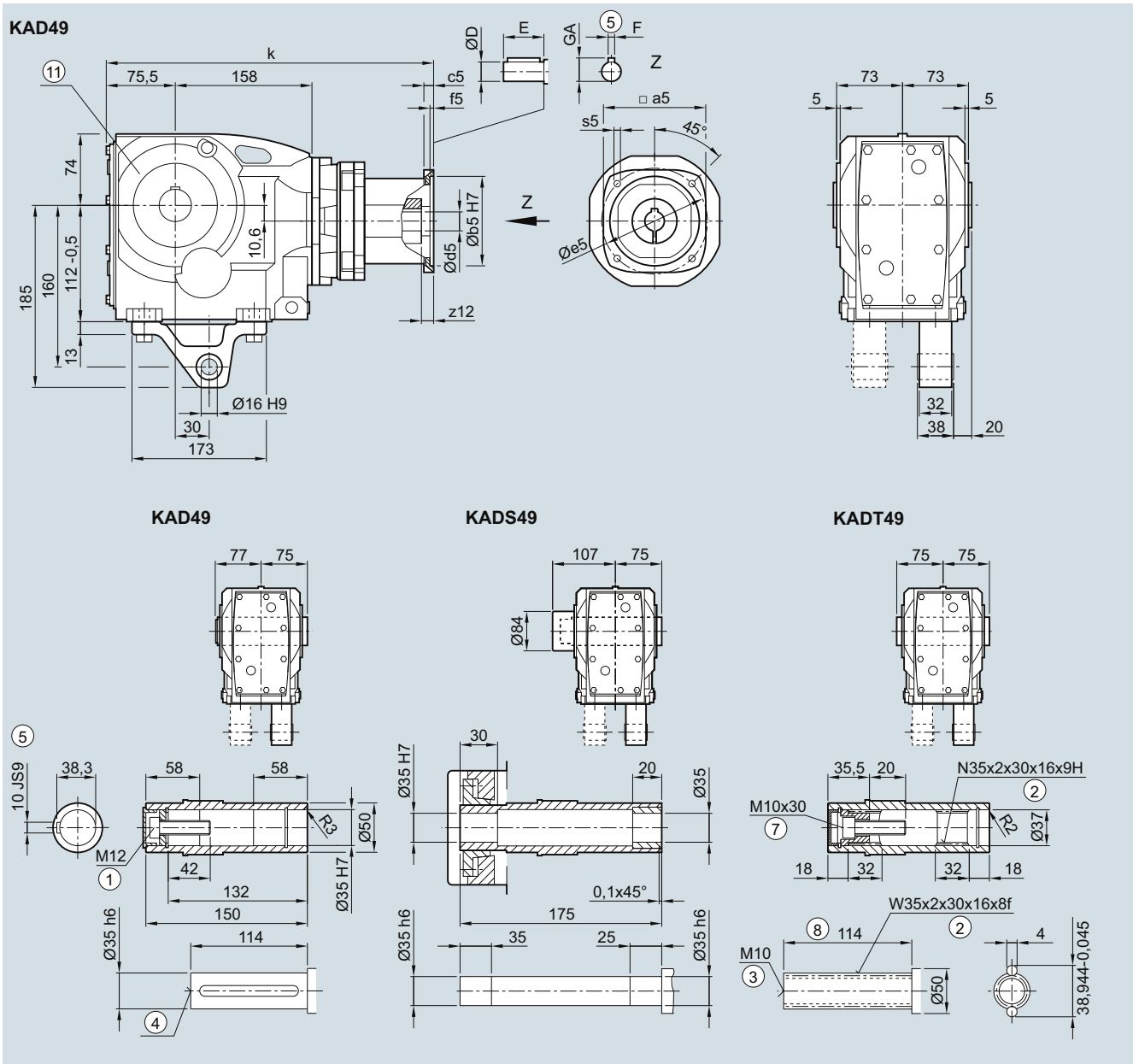

Adapter	a5	b5	c5	f5	e5	s5	z12	d5/D	E	F	GA	k
703	71.6	60	9	4.0	75	M5	18.0	14	30	5	16.0	323.5
704	96.5	80	10	4.0	100	M6	14.0	19	40	6	21.5	370.5
706	126.0	110	12	4.5	130	M8	15.0	24	50	8	27.0	383.5
708	155.0	130	15	4.5	165	M10	23.5	32	58	10	35.0	427.0
710	192.5	180	15	5.0	215	M12	33.0	38	80	10	41.0	496.0

- ① ISO 4014
- ② DIN 5480
- ③ DIN 332-D
- ④ DIN 332
- ⑤ Feather key/keyway DIN 6885
- ⑥ ISO 4762
- ⑦ Without locating shoulder +1 mm
- ⑧ Use bores only for housing flange design

SIMOGEAR Gearboxes

Bevel gearbox with adapter KQ

Dimensions

K.69 gearbox in a foot-mounted design

K030KQ, KA030KQ, KAS030KQ, KAT030KQ

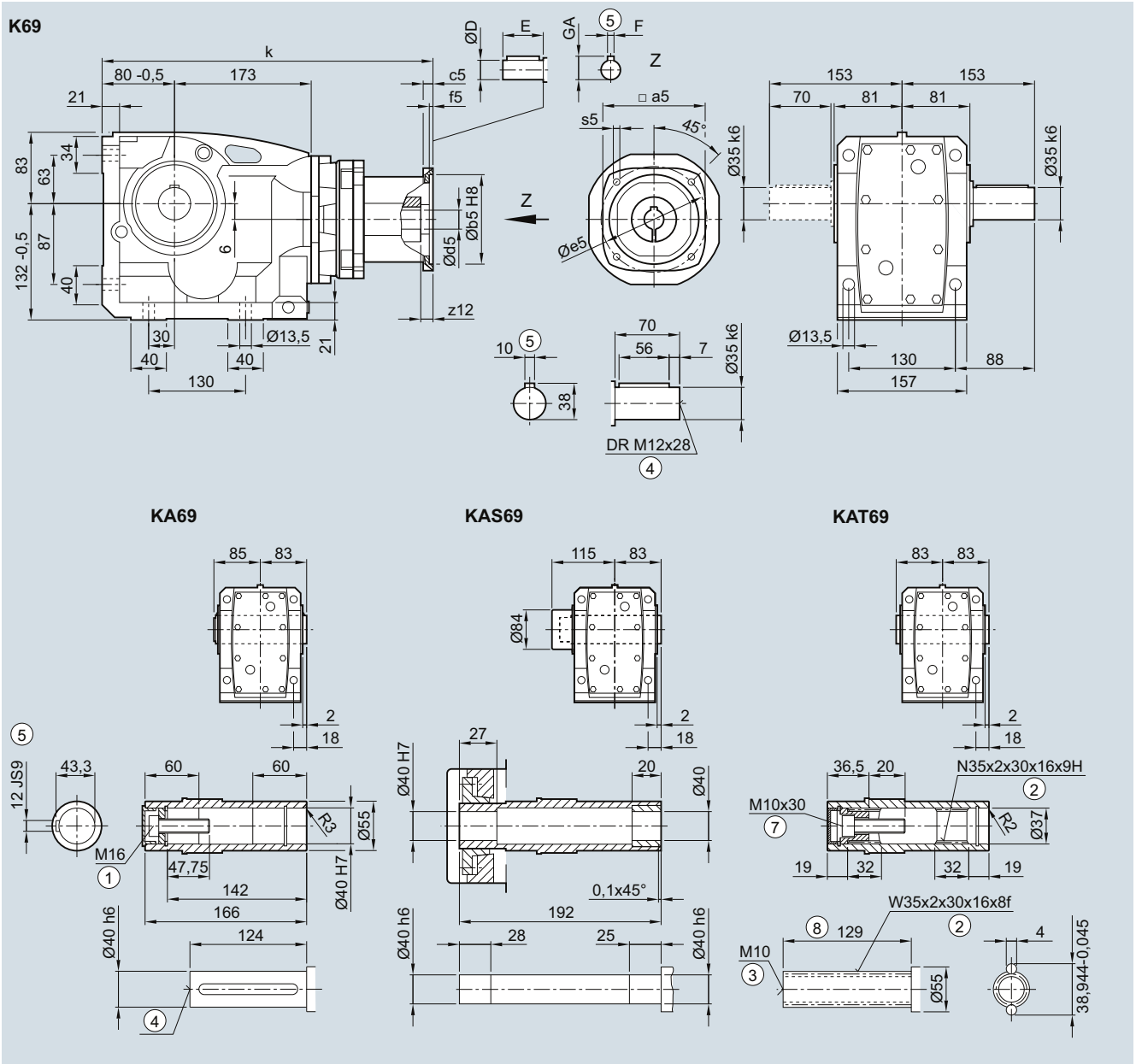

Adapter	a5	b5	c5	f5	e5	s5	z12	d5/D	E	F	GA	k
703	71.6	60	9	4.0	75	M5	18.0	14	30	5	16.0	343.0
704	96.5	80	10	4.0	100	M6	14.0	19	40	6	21.5	390.0
706	126.0	110	12	4.5	130	M8	15.0	24	50	8	27.0	403.0
708	155.0	130	15	4.5	165	M10	23.5	32	58	10	35.0	446.5
710	192.5	180	15	5.0	215	M12	33.0	38	80	10	41.0	515.5

① ISO 4014 ② DIN 5480 ③ DIN 332-D ④ DIN 332 ⑤ Feather key/keyway DIN 6885 ⑦ ISO 4762 ⑥ Without locating shoulder +1 mm

K.F.69 gearbox in a flange-mounted design

KF030KQ, KAF030KQ, KAFS030KQ, KAFT030KQ

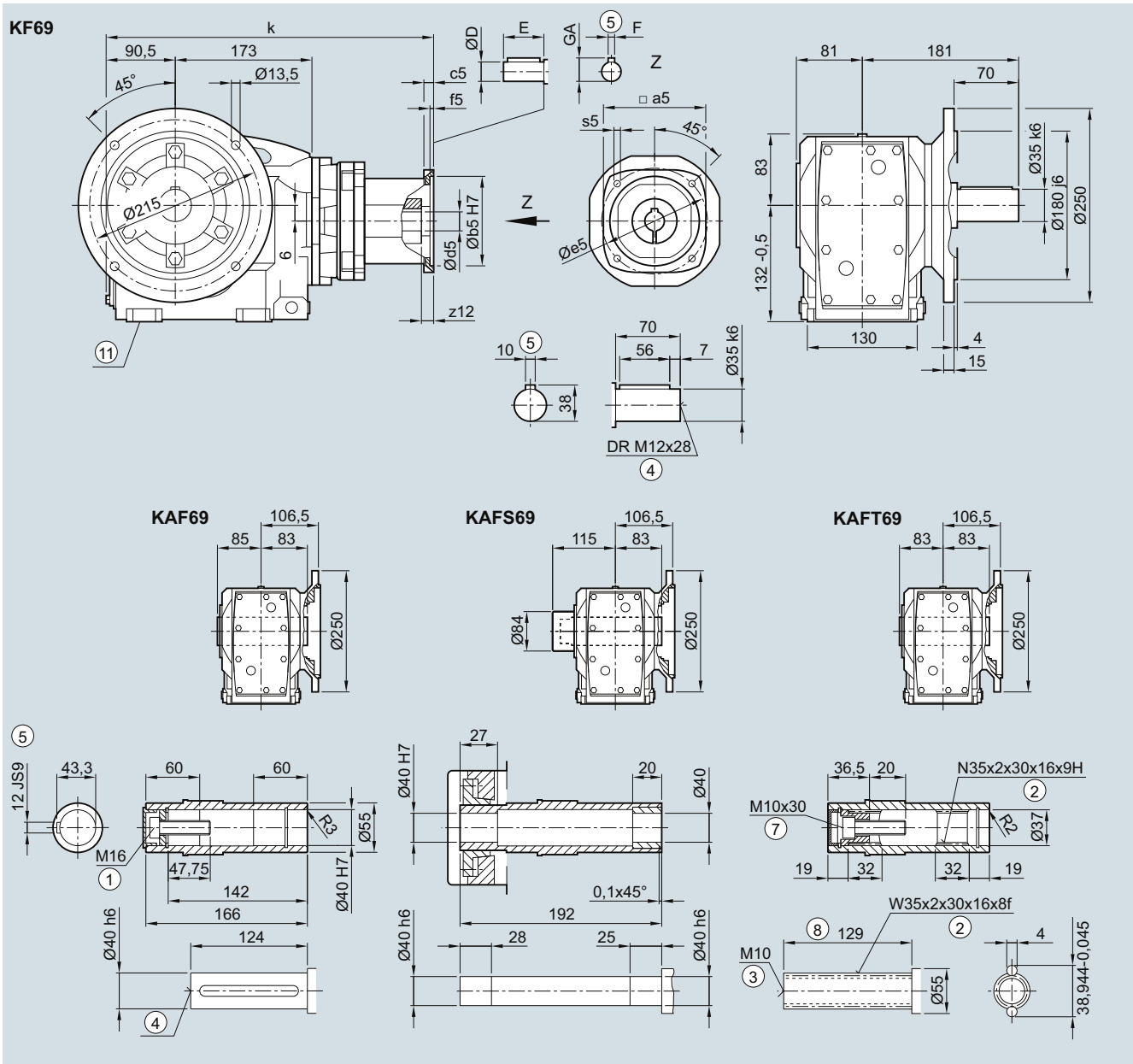

5

Adapter	a5	b5	c5	f5	e5	s5	z12	d5/D	E	F	GA	k
703	71.6	60	9	4.0	75	M5	18.0	14	30	5	16.0	353.5
704	96.5	80	10	4.0	100	M6	14.0	19	40	6	21.5	400.5
706	126.0	110	12	4.5	130	M8	15.0	24	50	8	27.0	413.5
708	155.0	130	15	4.5	165	M10	23.5	32	58	10	35.0	457.0
710	192.5	180	15	5.0	215	M12	33.0	38	80	10	41.0	526.0

① ISO 4014 ② DIN 5480 ③ DIN 332-D ④ DIN 332 ⑤ Feather key/keyway DIN 6885
 ⑥ ISO 4762 ⑦ Without locating shoulder +1 mm ⑧ Use bores only for foot-mounted design

SIMOGEAR Gearboxes

Bevel gearbox with adapter KQ

Dimensions

K.Z.69 gearbox in a housing flange design

KZ030KQ, KAZ030KQ, KAZS030KQ, KAZT030KQ

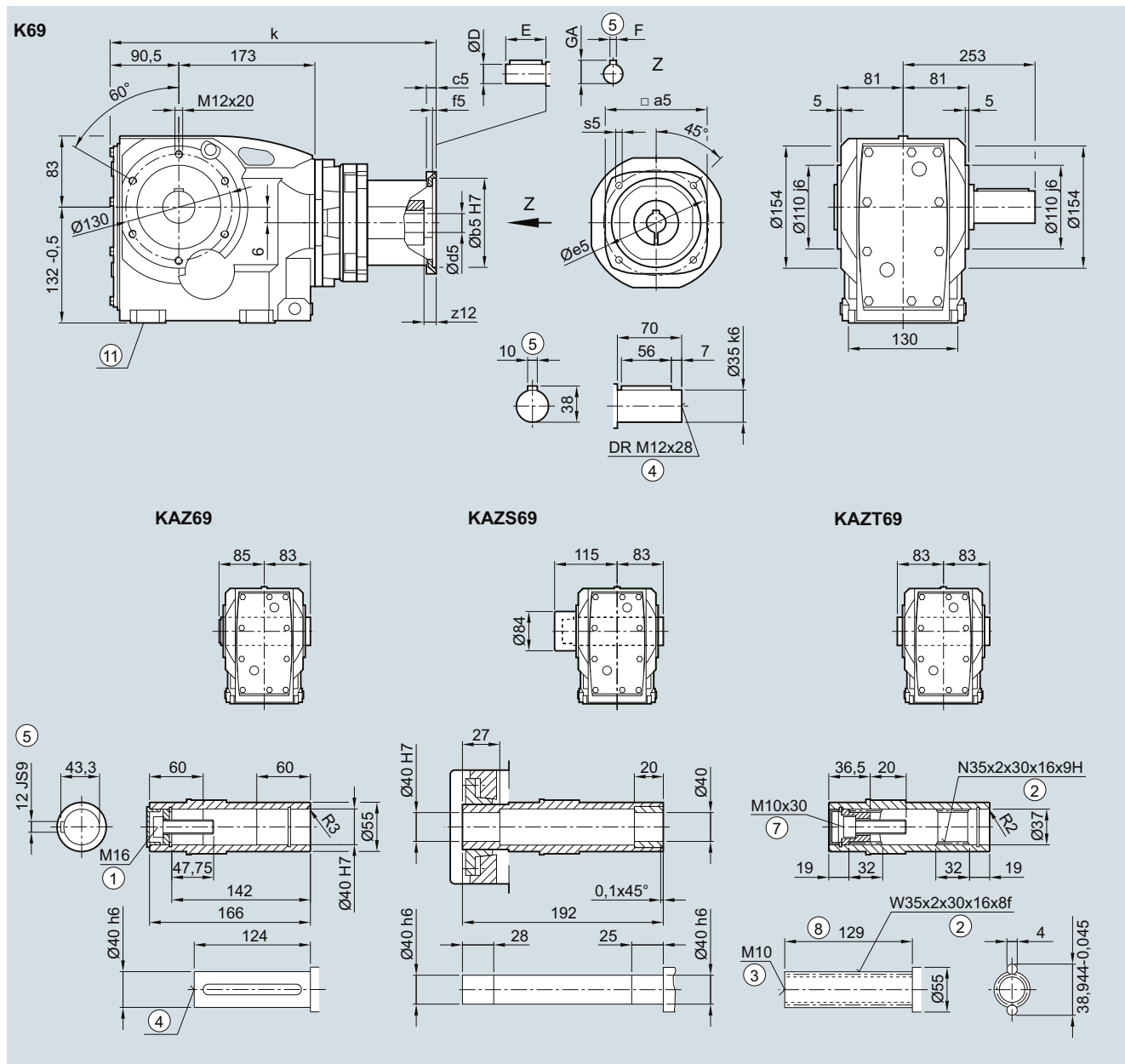

Adapter	a5	b5	c5	f5	e5	s5	z12	d5/D	E	F	GA	k
703	71.6	60	9	4.0	75	M5	18.0	14	30	5	16.0	353.5
704	96.5	80	10	4.0	100	M6	14.0	19	40	6	21.5	400.5
706	126.0	110	12	4.5	130	M8	15.0	24	50	8	27.0	413.5
708	155.0	130	15	4.5	165	M10	23.5	32	58	10	35.0	457.0
710	192.5	180	15	5.0	215	M12	33.0	38	80	10	41.0	526.0

- ① ISO 4014
- ② DIN 5480
- ③ DIN 332-D
- ④ DIN 332
- ⑤ Feather key/keyway DIN 6885
- ⑥ ISO 4762
- ⑦ Without locating shoulder +1 mm
- ⑧ Use bores only for foot-mounted design

KAD.69 gearbox in a shaft-mounted design

KAD030KQ, KADS030KQ, KADT030KQ

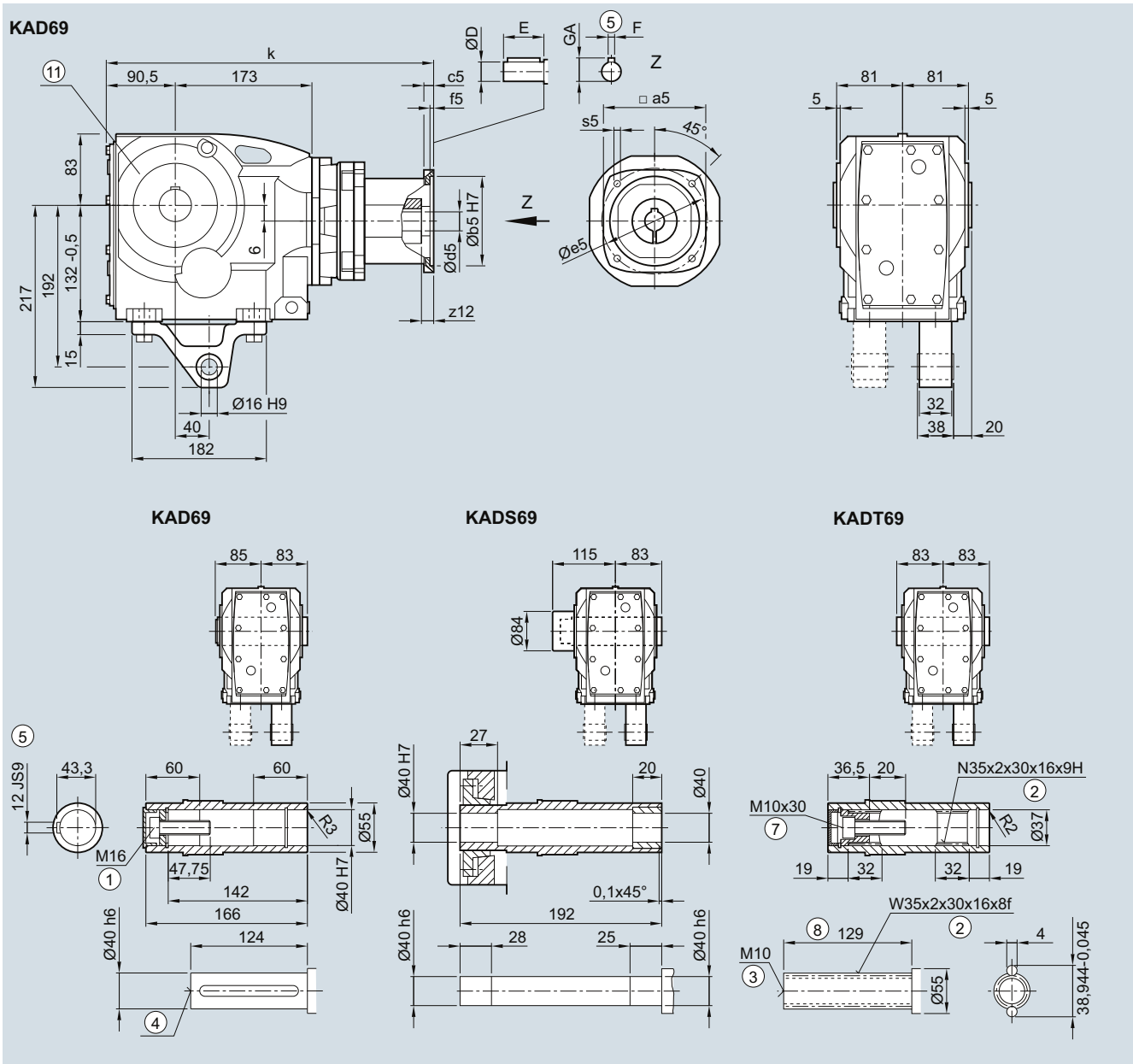

Adapter	a5	b5	c5	f5	e5	s5	z12	d5/D	E	F	GA	k
703	71.6	60	9	4.0	75	M5	18.0	14	30	5	16.0	353.5
704	96.5	80	10	4.0	100	M6	14.0	19	40	6	21.5	400.5
706	126.0	110	12	4.5	130	M8	15.0	24	50	8	27.0	413.5
708	155.0	130	15	4.5	165	M10	23.5	32	58	10	35.0	457.0
710	192.5	180	15	5.0	215	M12	33.0	38	80	10	41.0	526.0

- ① ISO 4014
- ② DIN 5480
- ③ DIN 332-D
- ④ DIN 332
- ⑤ Feather key/keyway DIN 6885
- ⑥ ISO 4762
- ⑦ Without locating shoulder +1 mm
- ⑧ Use bores only for housing flange design

SIMOGEAR Gearboxes

Bevel gearbox with adapter KQ

Dimensions

K.79 gearbox in a foot-mounted design

K030KQ, KA030, KQ KAS030KQ, KAT030KQ

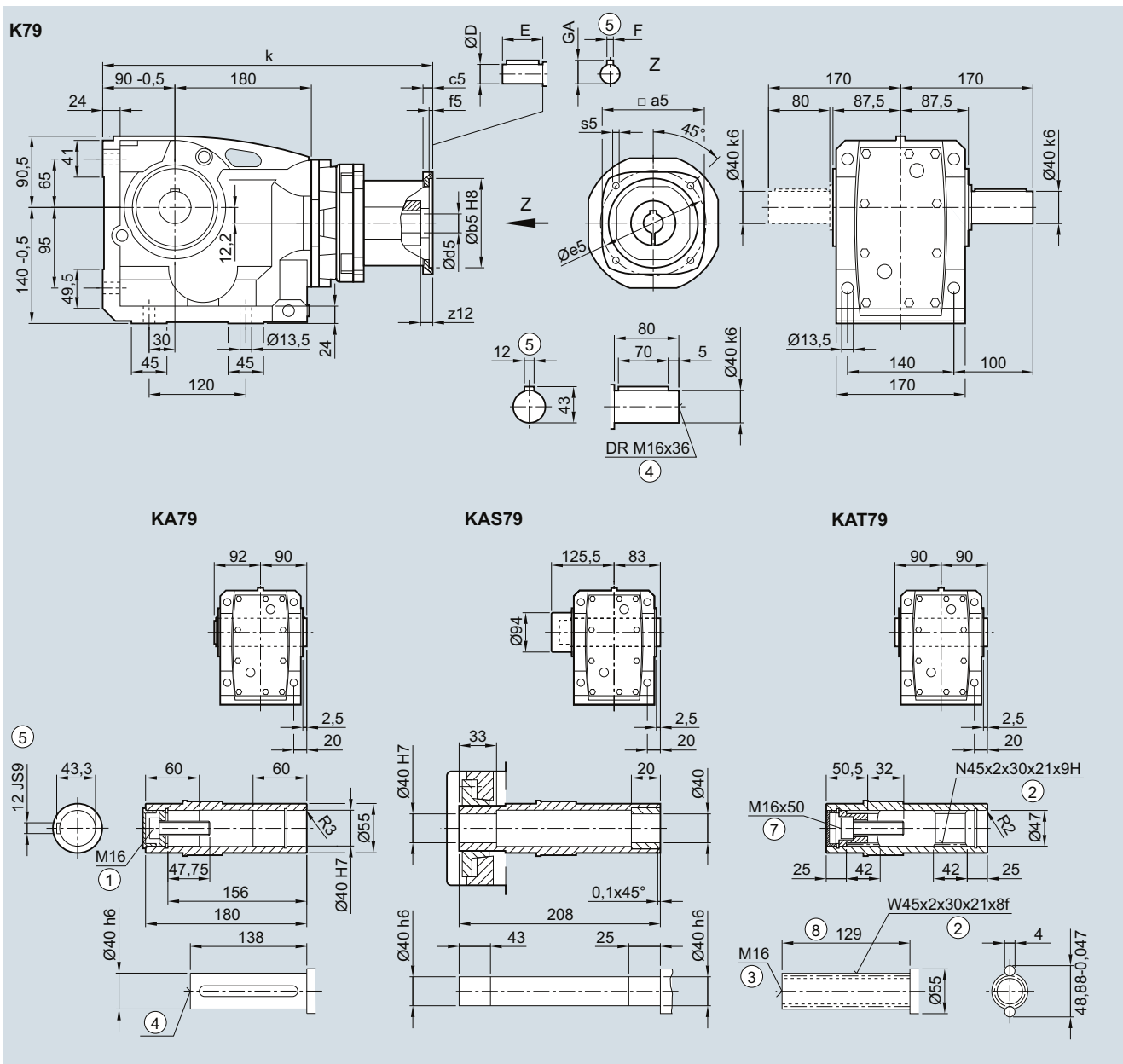

Adapter	a5	b5	c5	f5	e5	s5	z12	d5/D	E	F	GA	k
703	71.6	60	9	4.0	75	M5	18.0	14	30	5	16.0	360.0
704	96.5	80	10	4.0	100	M6	14.0	19	40	6	21.5	407.0
706	126.0	110	12	4.5	130	M8	15.0	24	50	8	27.0	420.0
708	155.0	130	15	4.5	165	M10	23.5	32	58	10	35.0	463.5
710	192.5	180	15	5.0	215	M12	33.0	38	80	10	41.0	532.5

① ISO 4014 ② DIN 5480 ③ DIN 332-D ④ DIN 332 ⑤ Feather key/keyway DIN 6885 ⑦ ISO 4762 ⑧ Without locating shoulder +1 mm

K.F.79 gearbox in a flange-mounted design

KF030KQ, KAF030KQ, KAFS030KQ, KAFT030KQ

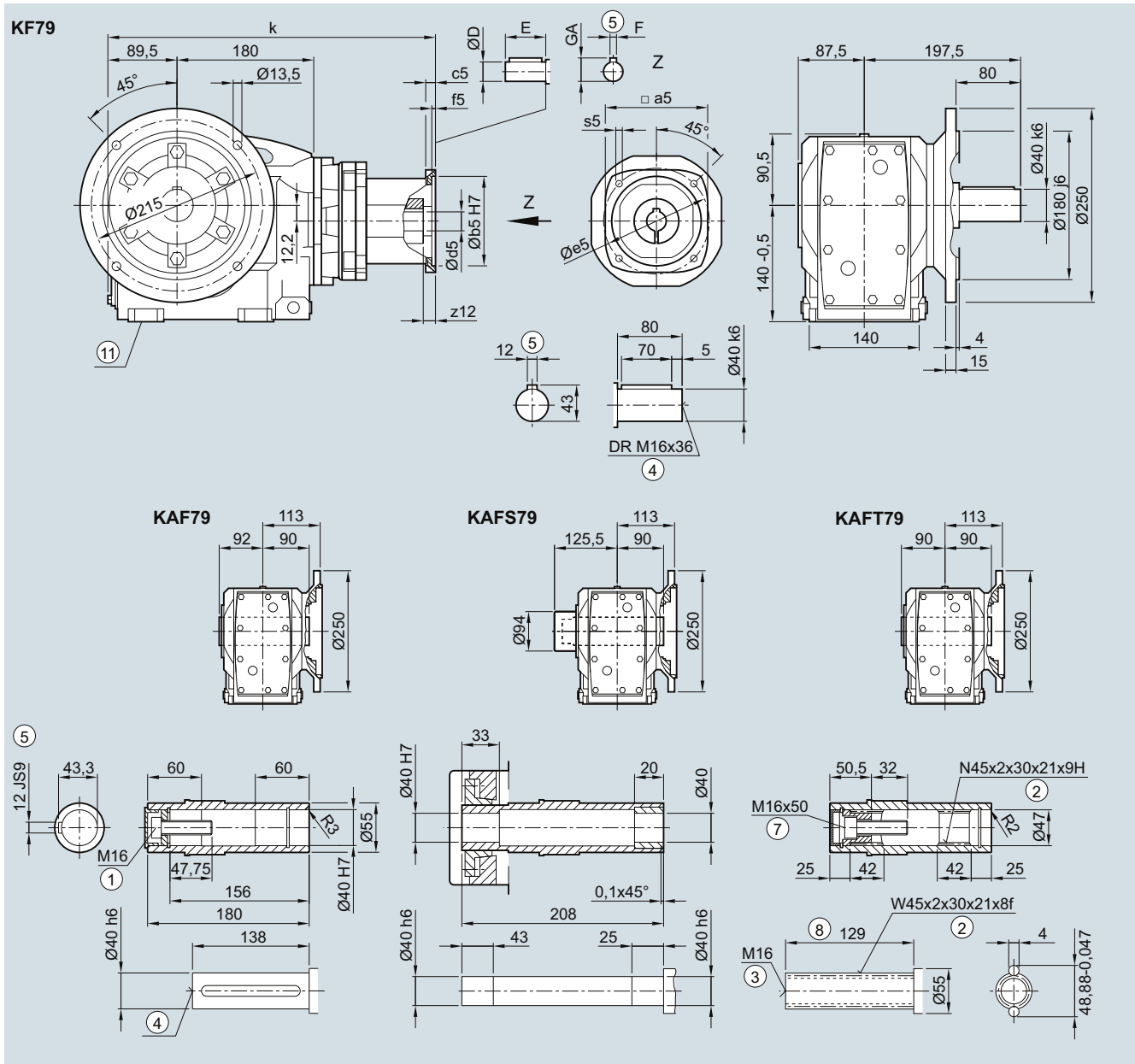

Adapter	a5	b5	c5	f5	e5	s5	z12	d5/D	E	F	GA	k
703	71.6	60	9	4.0	75	M5	18.0	14	30	5	16.0	359.5
704	96.5	80	10	4.0	100	M6	14.0	19	40	6	21.5	406.5
706	126.0	110	12	4.5	130	M8	15.0	24	50	8	27.0	419.5
708	155.0	130	15	4.5	165	M10	23.5	32	58	10	35.0	463.0
710	192.5	180	15	5.0	215	M12	33.0	38	80	10	41.0	532.0

① ISO 4014 ② DIN 5480 ③ DIN 332-D ④ DIN 332 ⑤ Feather key/keyway DIN 6885
 ⑥ ISO 4762 ⑦ Without locating shoulder +1 mm ⑧ Use bores only for foot-mounted design

SIMOGEAR Gearboxes

Bevel gearbox with adapter KQ

Dimensions

K.Z.79 gearbox in a housing flange design

KZ030KQ, KAZ030KQ, KAZS030KQ, KAZT030KQ

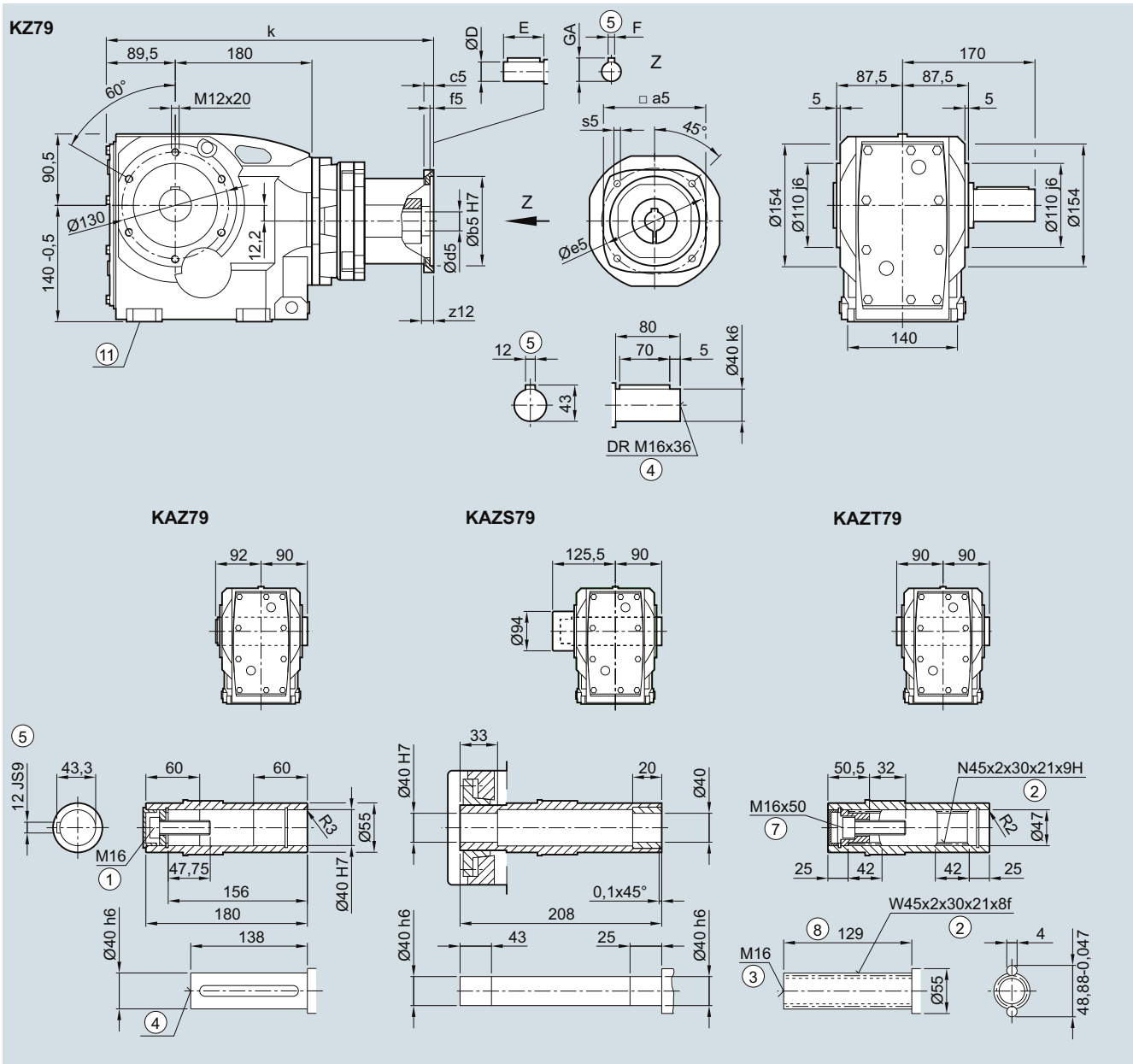

Adapter	a5	b5	c5	f5	e5	s5	z12	d5/D	E	F	GA	k
703	71.6	60	9	4.0	75	M5	18.0	14	30	5	16.0	359.5
704	96.5	80	10	4.0	100	M6	14.0	19	40	6	21.5	406.5
706	126.0	110	12	4.5	130	M8	15.0	24	50	8	27.0	419.5
708	155.0	130	15	4.5	165	M10	23.5	32	58	10	35.0	463.0
710	192.5	180	15	5.0	215	M12	33.0	38	80	10	41.0	532.0

① ISO 4014

② DIN 5480

③ DIN 332-D

④ DIN 332

⑤ Feather key/keyway DIN 6885

⑦ ISO 4762

⑧ Without locating shoulder +1 mm

⑨ Use bores only for foot-mounted design

KAD.79 gearbox in a shaft-mounted design

KAD030KQ, KADS030KQ, KADT030KQ

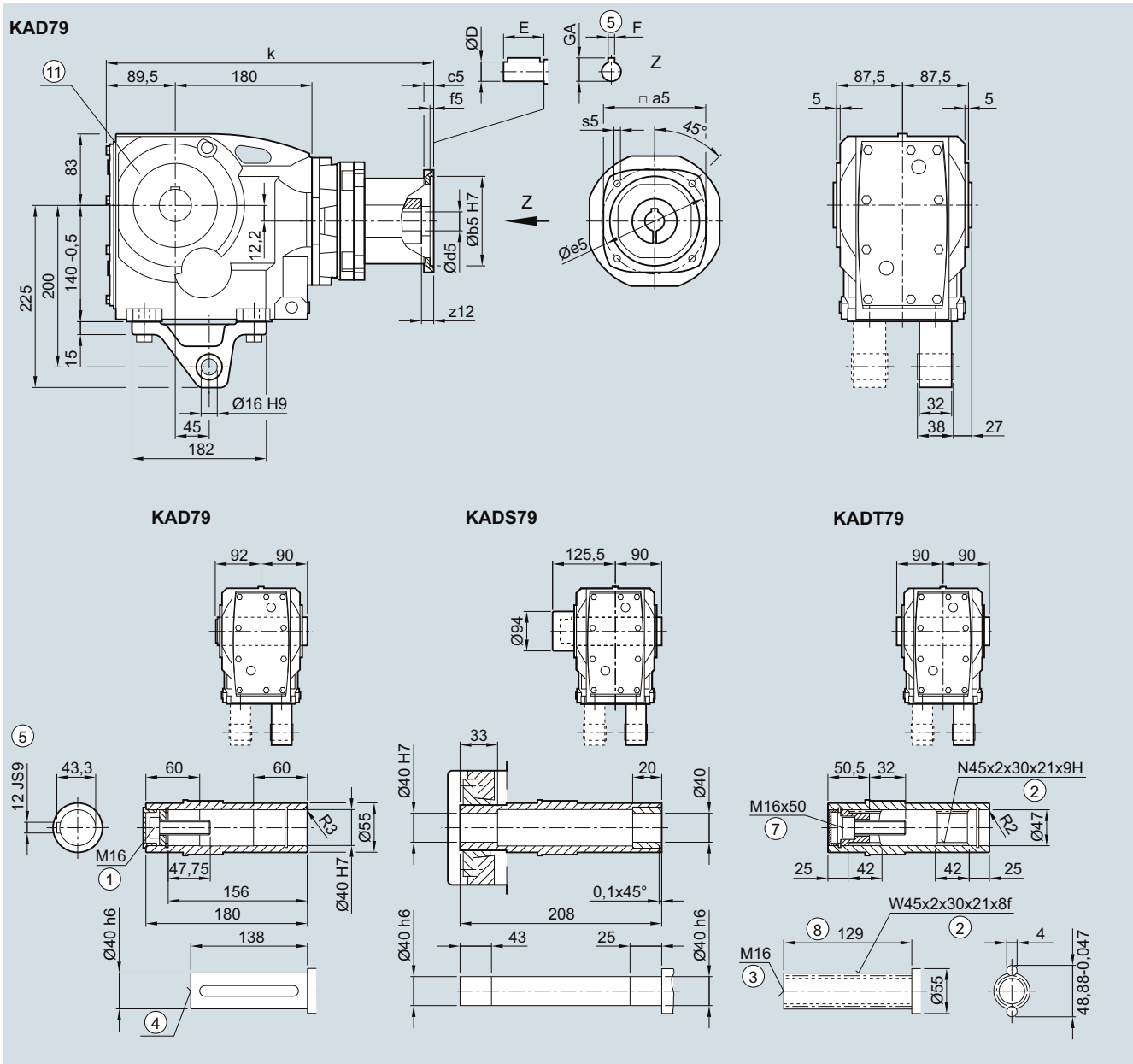

Adapter	a5	b5	c5	f5	e5	s5	z12	d5/D	E	F	GA	k
703	71.6	60	9	4.0	75	M5	18.0	14	30	5	16.0	359.5
704	96.5	80	10	4.0	100	M6	14.0	19	40	6	21.5	406.5
706	126.0	110	12	4.5	130	M8	15.0	24	50	8	27.0	419.5
708	155.0	130	15	4.5	165	M10	23.5	32	58	10	35.0	463.0
710	192.5	180	15	5.0	215	M12	33.0	38	80	10	41.0	532.0

① ISO 4014

② DIN 5480

③ DIN 332-D

④ DIN 332

⑤ Feather key/keyway DIN 6885

⑥ ISO 4762

⑦ Without locating shoulder +1 mm

⑧ Use bores only for housing flange design

SIMOGEAR Gearboxes

Bevel gearbox with adapter KQ

Dimensions

K.89 gearbox in a foot-mounted design

K030KQ, KA030KQ, KAS030KQ, KAT030KQ

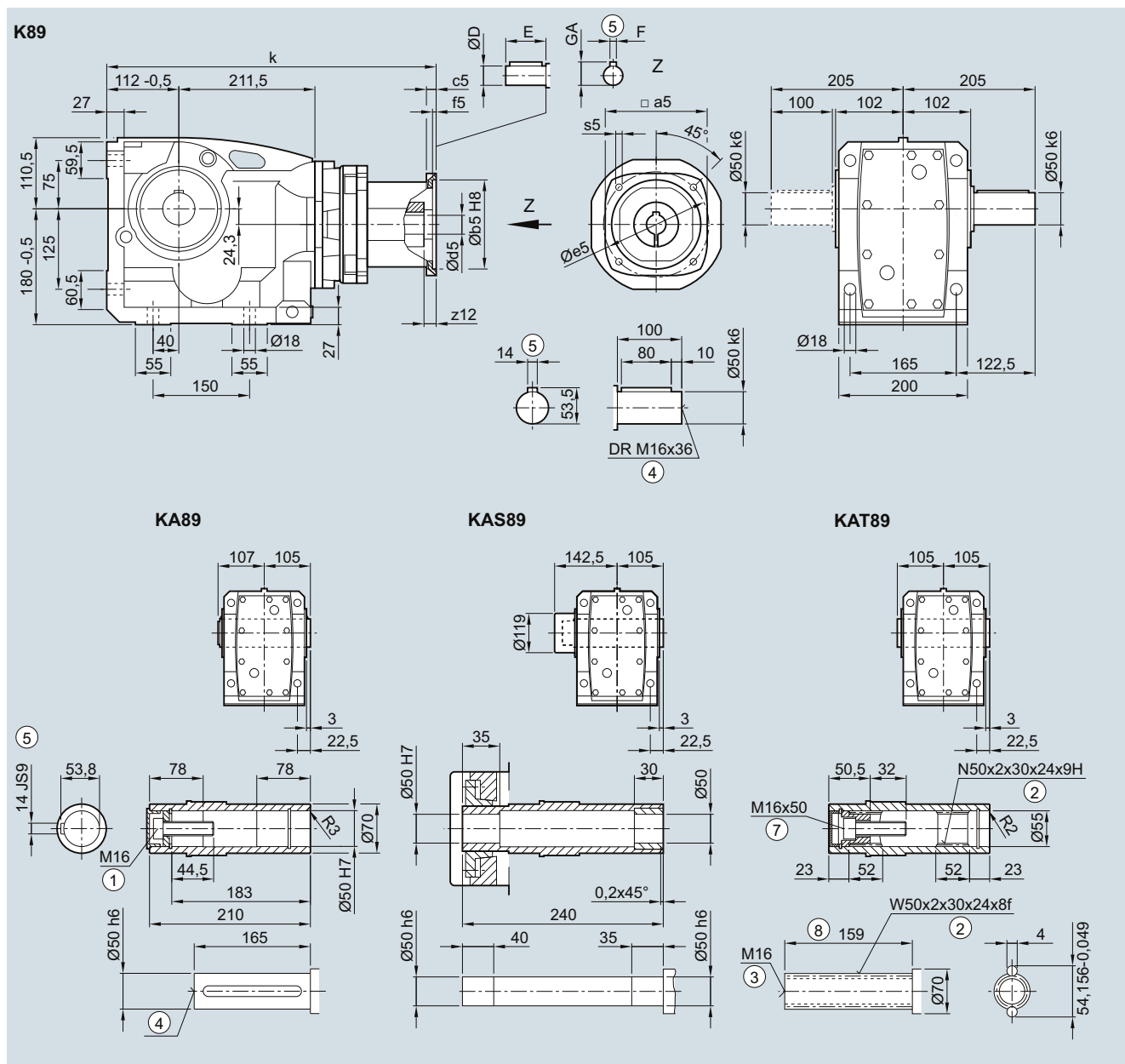

Adapter	a5	b5	c5	f5	e5	s5	z12	d5/D	E	F	GA	k
703	71.6	60	9	4.0	75	M5	18.0	14	30	5	16.0	411.5
704	96.5	80	10	4.0	100	M6	14.0	19	40	6	21.5	454.5
706	126.0	110	12	4.5	130	M8	15.0	24	50	8	27.0	467.5
708	155.0	130	15	4.5	165	M10	23.5	32	58	10	35.0	511.0
710	192.5	180	15	5.0	215	M12	33.0	38	80	10	41.0	580.0

① ISO 4014 ② DIN 5480 ③ DIN 332-D ④ DIN 332 ⑤ Feather key/keyway DIN 6885 ⑦ ISO 4762 ⑧ Without locating shoulder +1 mm

K.F.89 gearbox in a flange-mounted design

KF030KQ, KAF030KQ, KAFS030KQ, KAFT030KQ

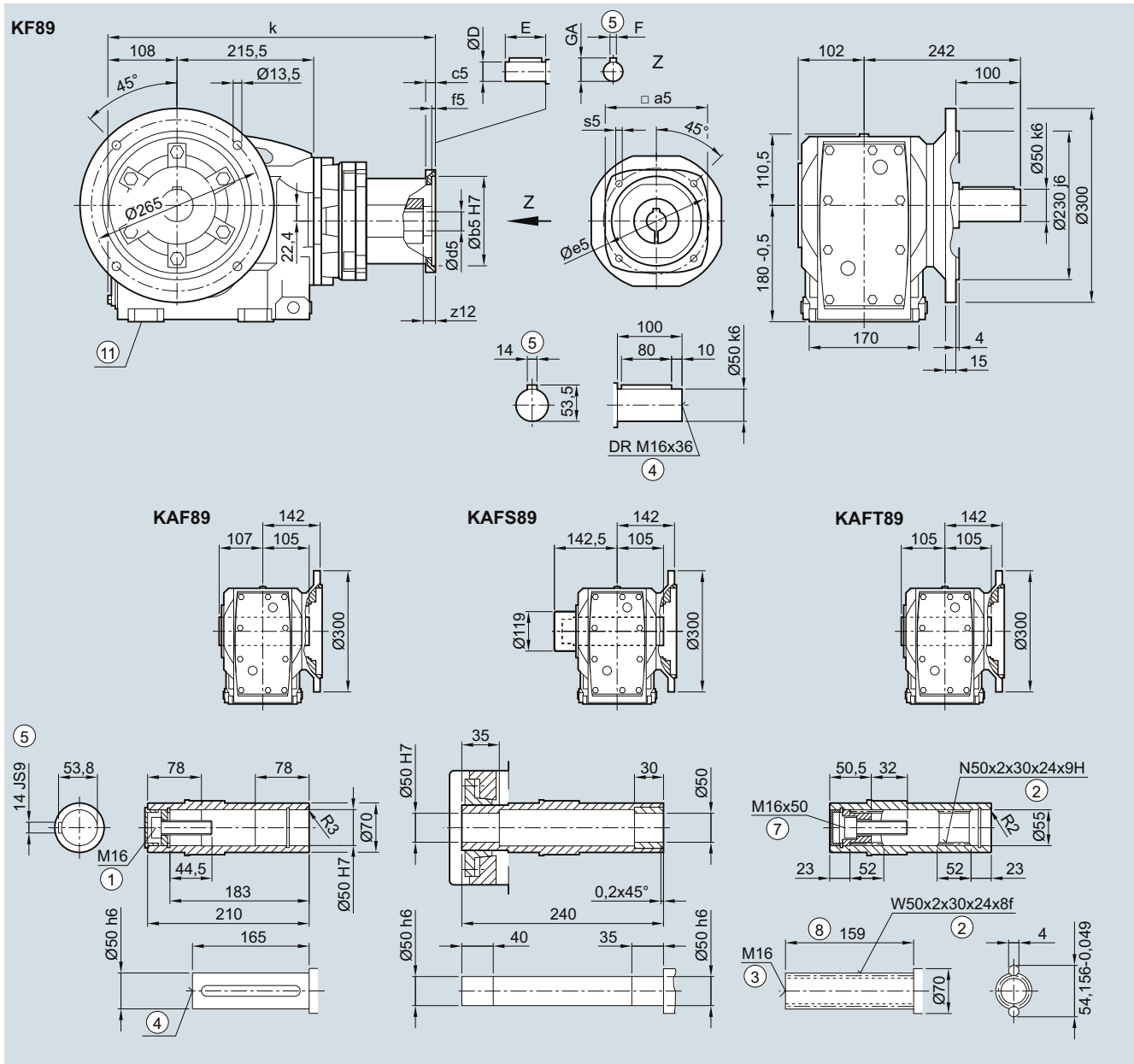

Adapter	a5	b5	c5	f5	e5	s5	z12	d5/D	E	F	GA	k
703	71.6	60	9	4.0	75	M5	18.0	14	30	5	16.0	411.5
704	96.5	80	10	4.0	100	M6	14.0	19	40	6	21.5	454.5
706	126.0	110	12	4.5	130	M8	15.0	24	50	8	27.0	467.5
708	155.0	130	15	4.5	165	M10	23.5	32	58	10	35.0	511.0
710	192.5	180	15	5.0	215	M12	33.0	38	80	10	41.0	580.0

- ① ISO 4014 ② DIN 5480 ③ DIN 332-D ④ DIN 332 ⑤ Feather key/keyway DIN 6885
- ⑦ ISO 4762 ⑧ Without locating shoulder +1 mm ⑨ Use bores only for foot-mounted design

SIMOGEAR Gearboxes

Bevel gearbox with adapter KQ

Dimensions

K.Z.89 gearbox in a housing flange design

KZ030KQ, KAZ030KQ, KAZS030KQ, KAZT030KQ

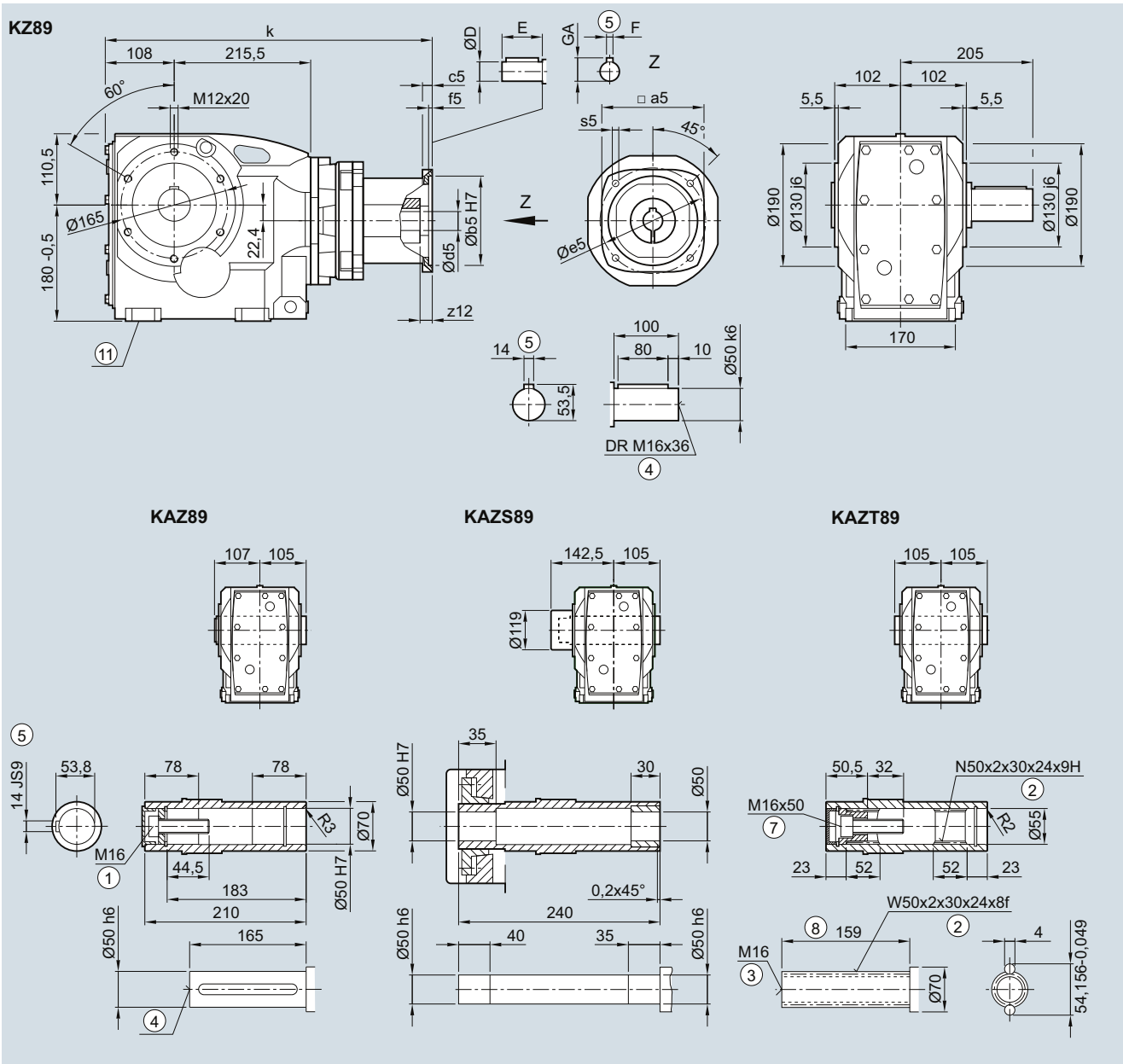

Adapter	a5	b5	c5	f5	e5	s5	z12	d5/D	E	F	GA	k
703	71.6	60	9	4.0	75	M5	18.0	14	30	5	16.0	411.5
704	96.5	80	10	4.0	100	M6	14.0	19	40	6	21.5	454.5
706	126.0	110	12	4.5	130	M8	15.0	24	50	8	27.0	467.5
708	155.0	130	15	4.5	165	M10	23.5	32	58	10	35.0	511.0
710	192.5	180	15	5.0	215	M12	33.0	38	80	10	41.0	580.0

① ISO 4014
② ISO 4762

③ DIN 5480
④ Without locating shoulder +1 mm

⑤ DIN 332-D

⑥ DIN 332

⑦ Feather key/keyway DIN 6885

⑧ Use bores only for foot-mounted design

KAD.89 gearbox in a shaft-mounted design

KAD030KQ, KADS030KQ, KADT030KQ

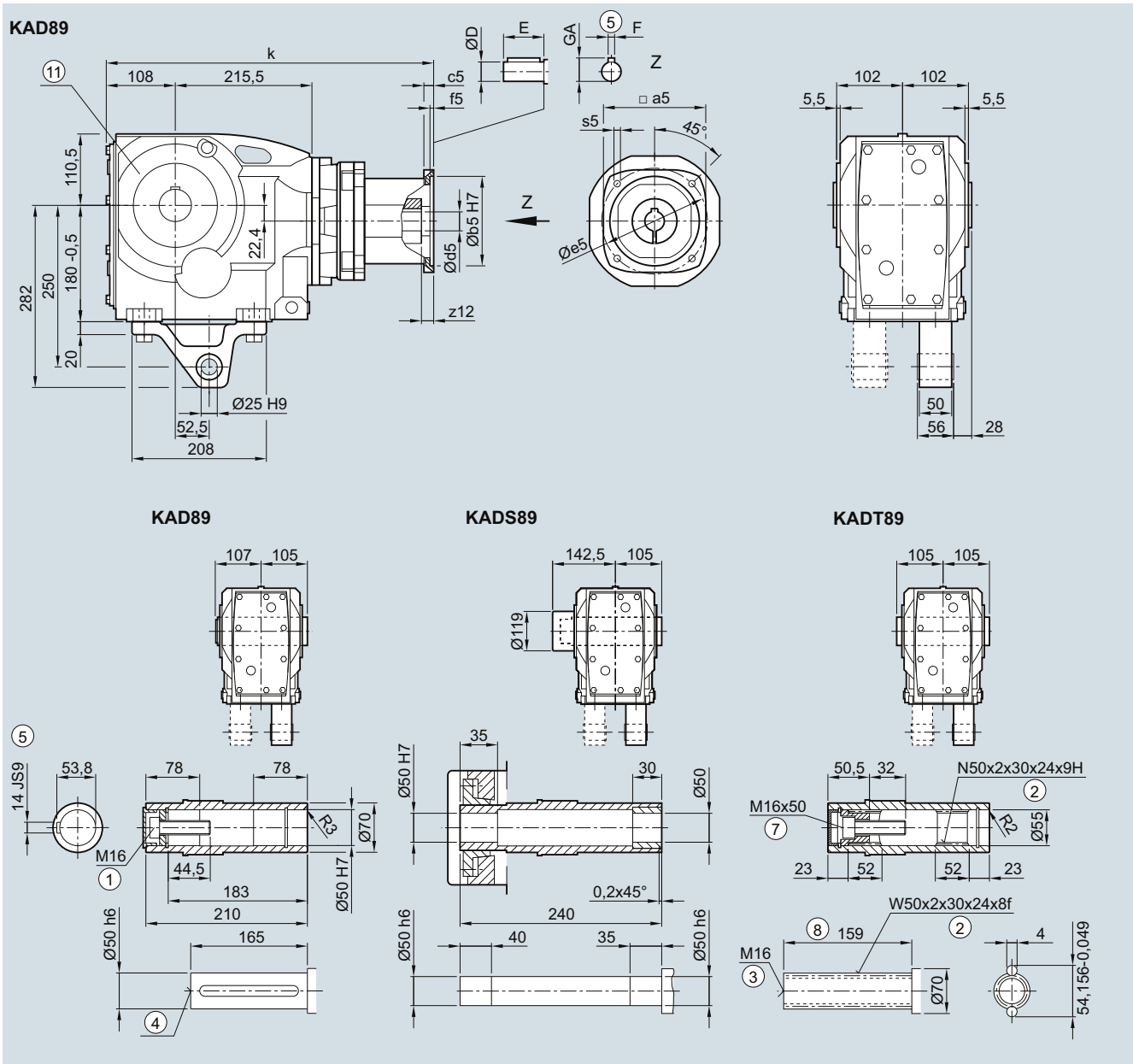

5

Adapter	a5	b5	c5	f5	e5	s5	z12	d5/D	E	F	GA	k
703	71.6	60	9	4.0	75	M5	18.0	14	30	5	16.0	411.5
704	96.5	80	10	4.0	100	M6	14.0	19	40	6	21.5	454.5
706	126.0	110	12	4.5	130	M8	15.0	24	50	8	27.0	467.5
708	155.0	130	15	4.5	165	M10	23.5	32	58	10	35.0	511.0
710	192.5	180	15	5.0	215	M12	33.0	38	80	10	41.0	580.0

- ① ISO 4014
- ② DIN 5480
- ③ DIN 332-D
- ④ DIN 332
- ⑤ Feather key/keyway DIN 6885
- ⑥ ISO 4762
- ⑦ Without locating shoulder +1 mm
- ⑧ Use bores only for housing flange design

SIMOGEAR Gearboxes

Bevel gearbox with adapter KQ

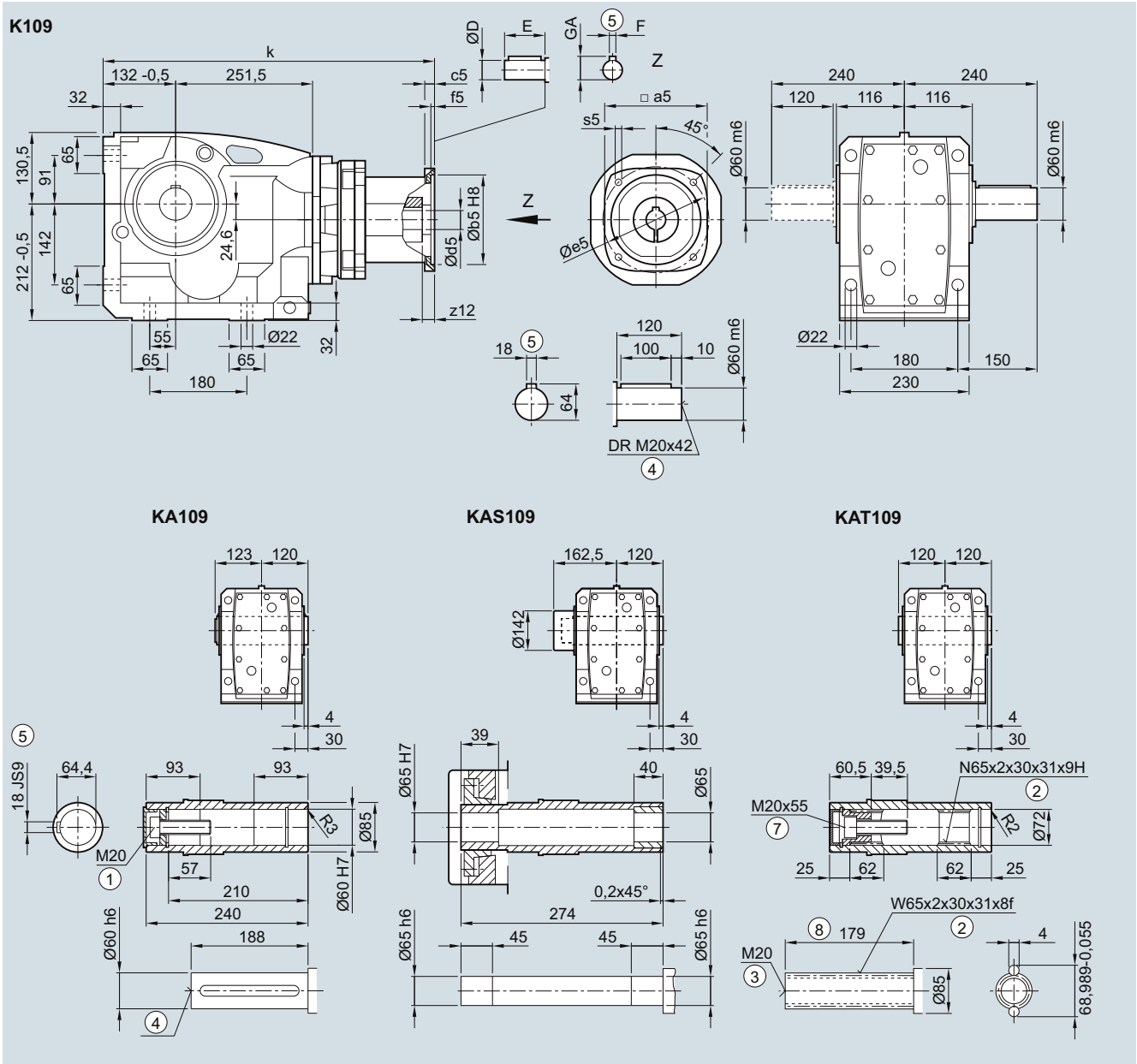
Dimensions**K.109 gearbox in a foot-mounted design****K030KQ, KA030KQ, KAS030KQ, KAT030KQ**

Adapter	a5	b5	c5	f5	e5	s5	z12	d5/D	E	F	GA	k
704	96.5	80	10	4.0	100	M6	14.0	19	40	6	21.5	501.5
706	126.0	110	12	4.5	130	M8	15.0	24	50	8	27.0	514.5
708	155.0	130	15	4.5	165	M10	23.5	32	58	10	35.0	554.0
710	192.5	180	15	5.0	215	M12	33.0	38	80	10	41.0	623.0

① ISO 4014 ② DIN 5480 ③ DIN 332-D ④ DIN 332 ⑤ Feather key/keyway DIN 6885 ⑦ ISO 4762 ⑧ Without locating shoulder +1 mm

K.F.109 gearbox in a flange-mounted design

KF030KQ, KAF030KQ, KAFS030KQ, KAFT030KQ

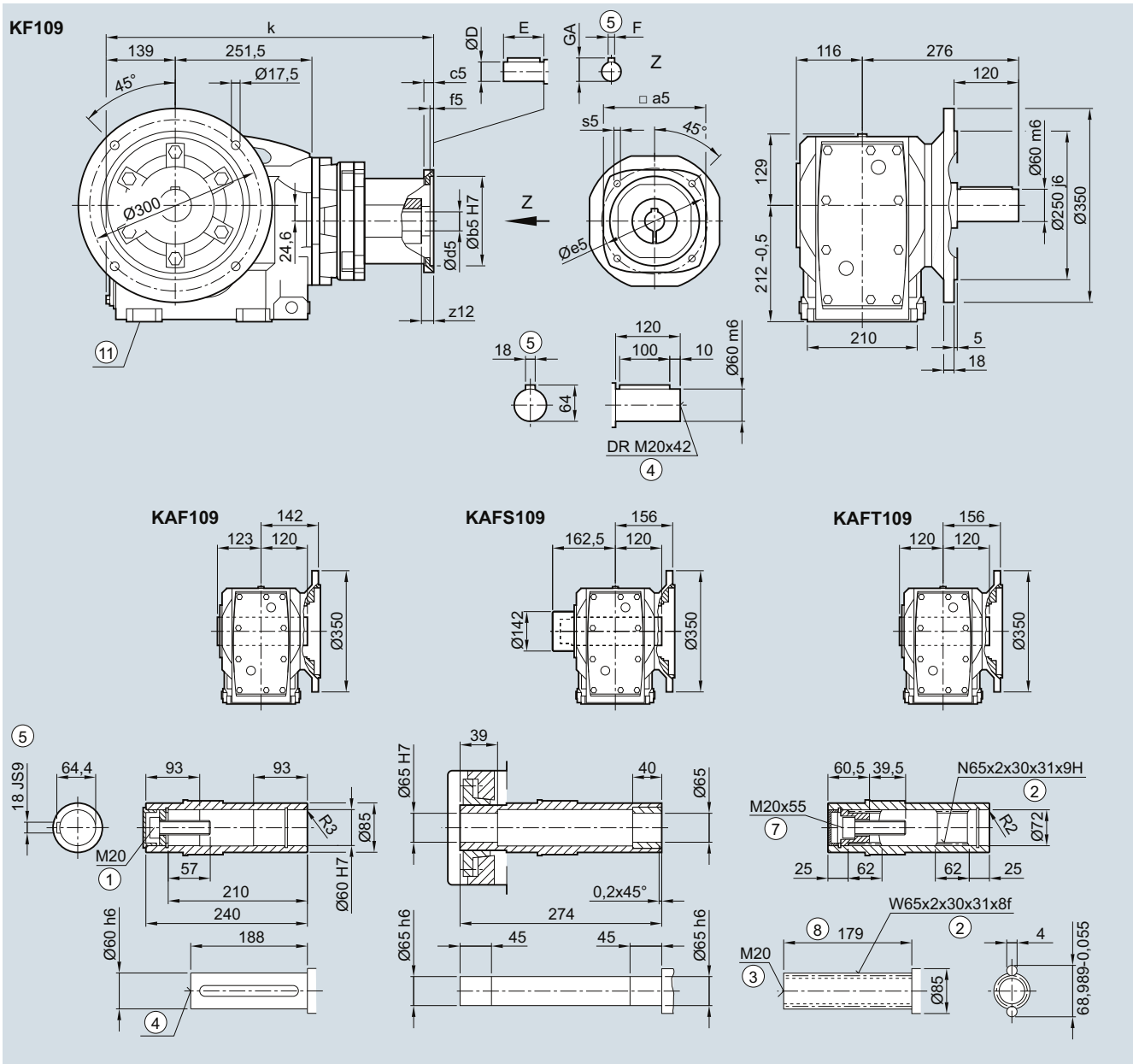

Adapter	a5	b5	c5	f5	e5	s5	z12	d5/D	E	F	GA	k
704	96.5	80	10	4.0	100	M6	14.0	19	40	6	21.5	508.5
706	126.0	110	12	4.5	130	M8	15.0	24	50	8	27.0	521.5
708	155.0	130	15	4.5	165	M10	23.5	32	58	10	35.0	561.0
710	192.5	180	15	5.0	215	M12	33.0	38	80	10	41.0	630.0

- ① ISO 4014 ② DIN 5480 ③ DIN 332-D ④ DIN 332 ⑤ Feather key/keyway DIN 6885
- ⑦ ISO 4762 ⑧ Without locating shoulder +1 mm ⑨ Use bores only for foot-mounted design

SIMOGEAR Gearboxes

Bevel gearbox with adapter KQ

Dimensions

K.Z.109 gearbox in a housing flange design

KZ030KQ, KAZ030KQ, KAZS030KQ, KAZT030KQ

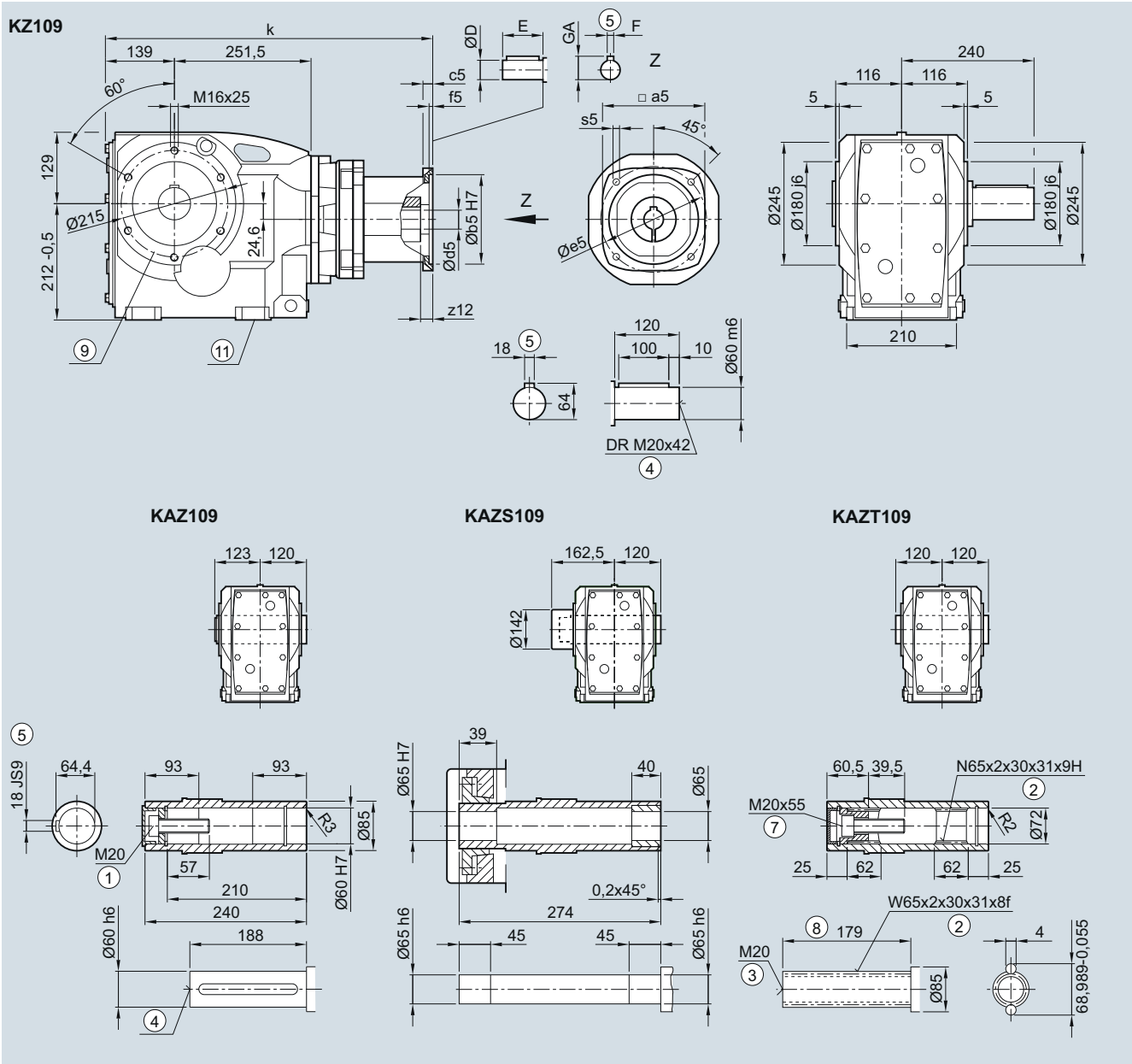

Adapter	a5	b5	c5	f5	e5	s5	z12	d5/D	E	F	GA	k
704	96.5	80	10	4.0	100	M6	14.0	19	40	6	21.5	508.5
706	126.0	110	12	4.5	130	M8	15.0	24	50	8	27.0	521.5
708	155.0	130	15	4.5	165	M10	23.5	32	58	10	35.0	561.0
710	192.5	180	15	5.0	215	M12	33.0	38	80	10	41.0	630.0

① ISO 4014 ② DIN 5480 ③ DIN 332-D ④ DIN 332 ⑤ Feather key/keyway DIN 6885
 ⑦ ISO 4762 ⑧ Without locating shoulder +1 mm ⑨ For pin holes, see 4/131 ⑩ Use bores only for foot-mounted design

KAD.109 gearbox in a shaft-mounted design

KAD030KQ, KADS030KQ, KADT030KQ

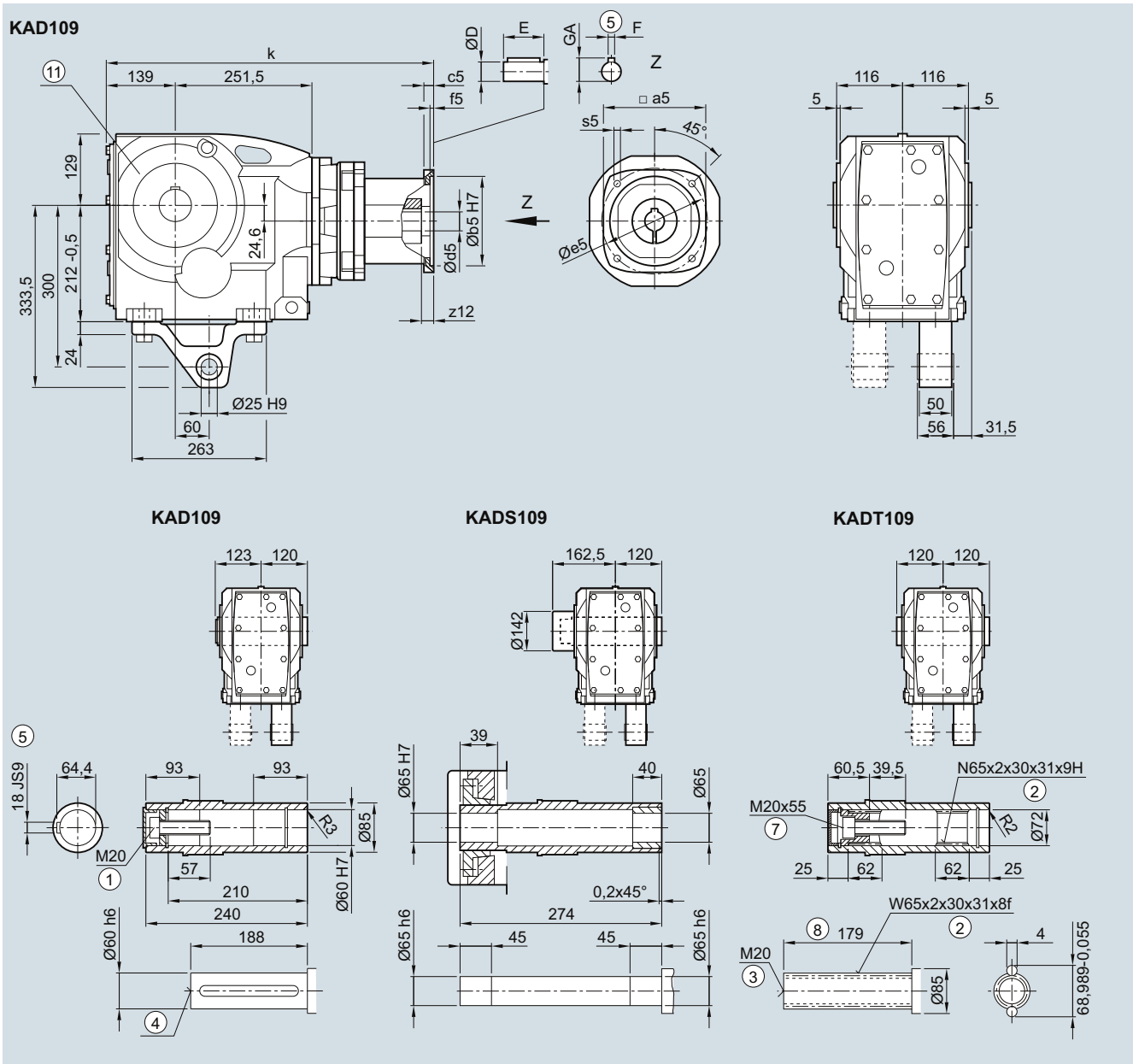

5

Adapter	a5	b5	c5	f5	e5	s5	z12	d5/D	E	F	GA	k
704	96.5	80	10	4.0	100	M6	14.0	19	40	6	21.5	508.5
706	126.0	110	12	4.5	130	M8	15.0	24	50	8	27.0	521.5
708	155.0	130	15	4.5	165	M10	23.5	32	58	10	35.0	561.0
710	192.5	180	15	5.0	215	M12	33.0	38	80	10	41.0	630.0

- ① ISO 4014
- ② DIN 5480
- ③ DIN 332-D
- ④ DIN 332
- ⑤ Feather key/keyway DIN 6885
- ⑦ ISO 4762
- ⑧ Without locating shoulder +1 mm
- ⑨ Use bores only for housing flange design

SIMOGEAR Gearboxes

Bevel gearbox with adapter KQ

Dimensions

K.129 gearbox in a foot-mounted design

K030KQ, KA030KQ, KAS030KQ, KAT030KQ

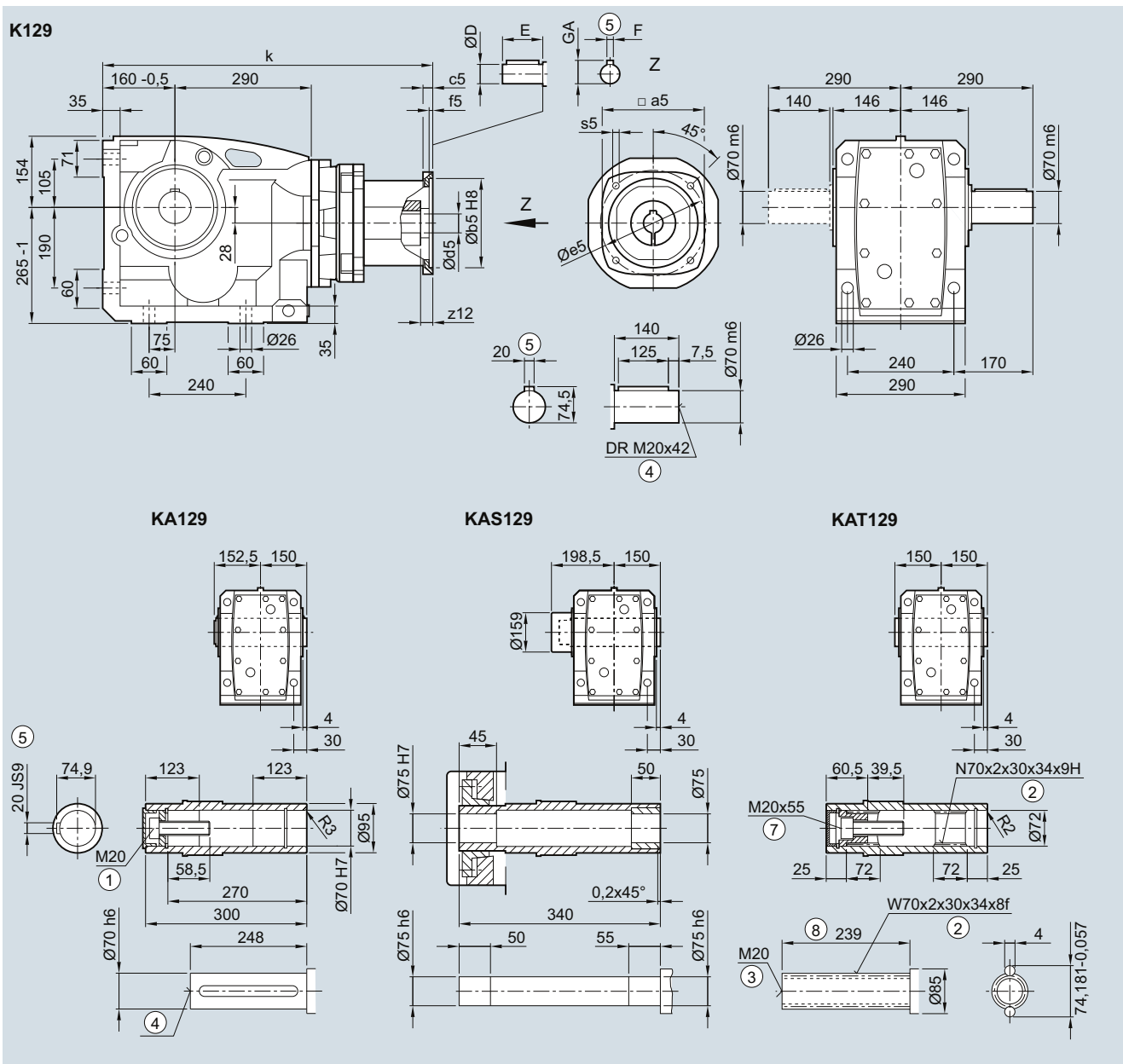

Adapter	a5	b5	c5	f5	e5	s5	z12	d5/D	E	F	GA	k
706	126.0	110	12	4.5	130	M8	15.0	24	50	8	27.0	574.0
708	155.0	130	15	4.5	165	M10	23.5	32	58	10	35.0	611.5
710	192.5	180	15	5.0	215	M12	33.0	38	80	10	41.0	680.5

① ISO 4014 ② DIN 5480 ③ DIN 332-D ④ DIN 332 ⑤ Feather key/keyway DIN 6885 ⑦ ISO 4762 ⑥ Without locating shoulder +1 mm

K.F.129 gearbox in a flange-mounted design

KF030KQ, KAF030KQ, KAFS030KQ, KAFT030KQ

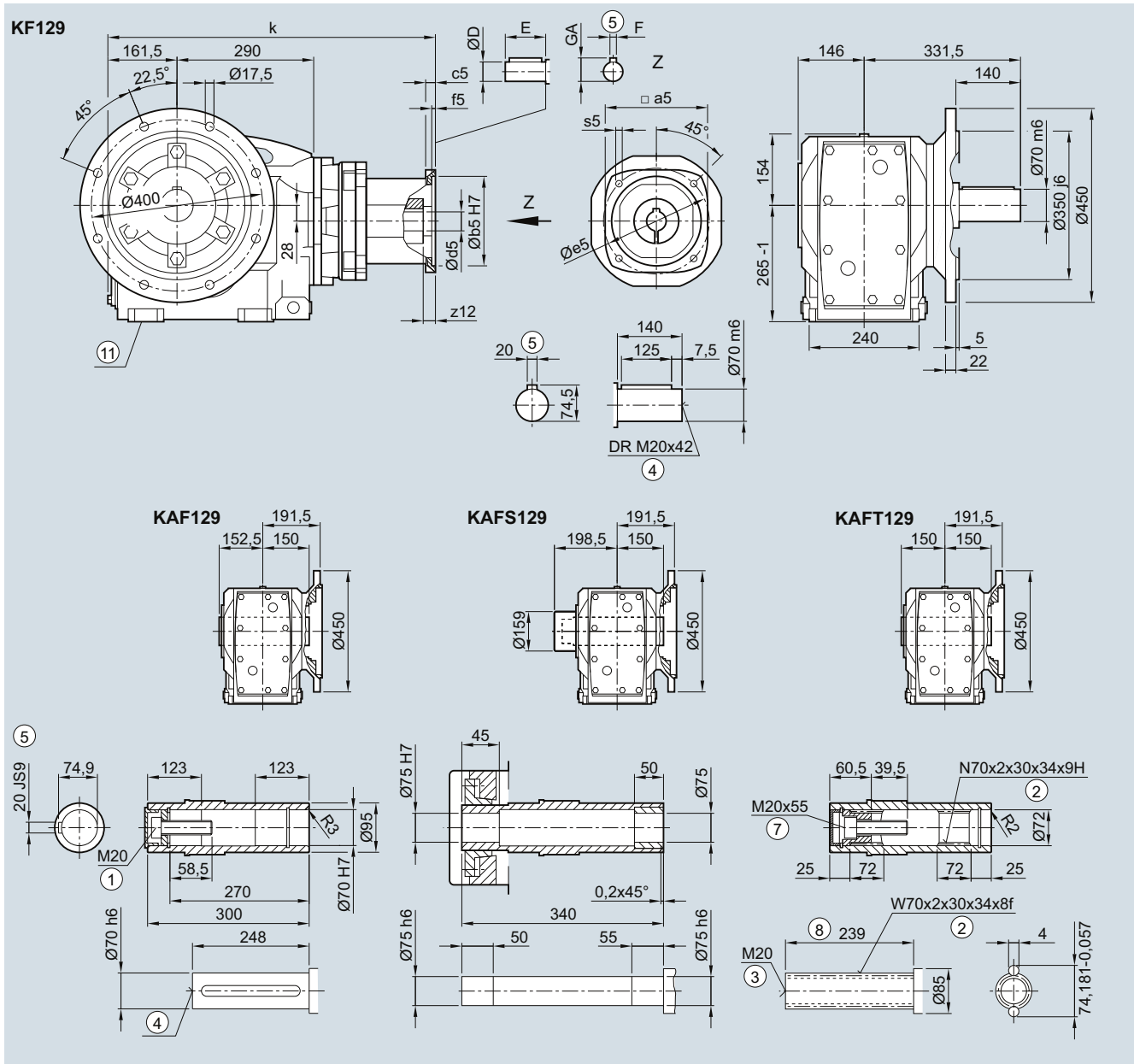

5

Adapter	a5	b5	c5	f5	e5	s5	z12	d5/D	E	F	GA	k
706	126.0	110	12	4.5	130	M8	15.0	24	50	8	27.0	575.5
708	155.0	130	15	4.5	165	M10	23.5	32	58	10	35.0	613.0
710	192.5	180	15	5.0	215	M12	33.0	38	80	10	41.0	682.0

- ① ISO 4014 ② DIN 5480 ③ DIN 332-D ④ DIN 332 ⑤ Feather key/keyway DIN 6885
- ⑦ ISO 4762 ⑧ Without locating shoulder +1 mm ⑨ Use bores only for foot-mounted design

SIMOGEAR Gearboxes

Bevel gearbox with adapter KQ

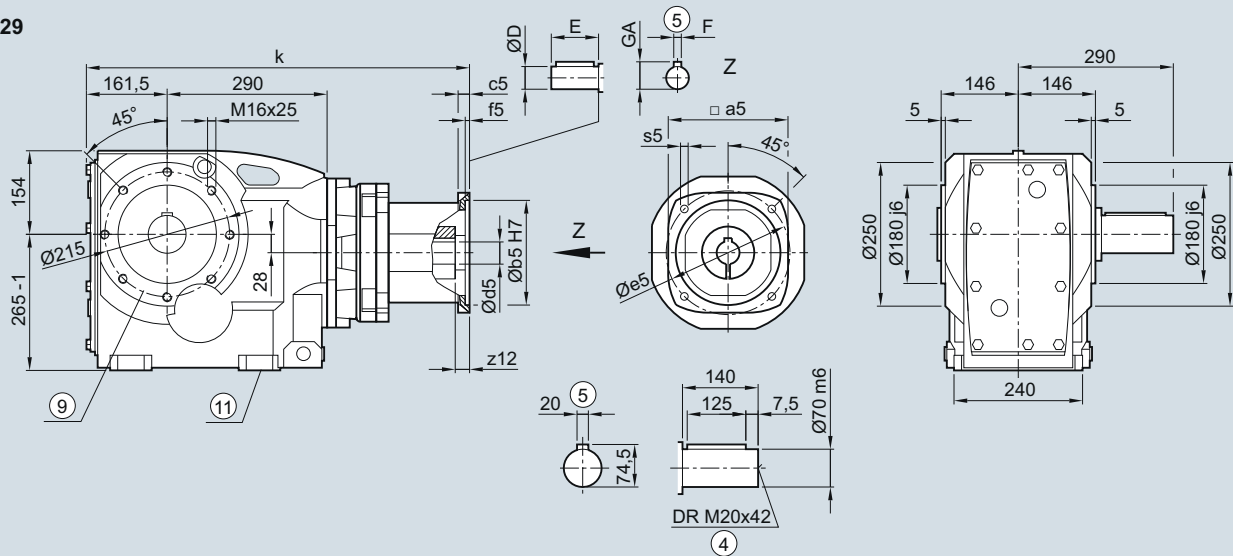
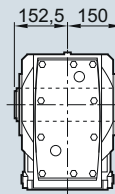
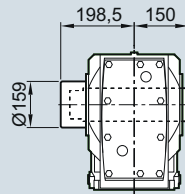
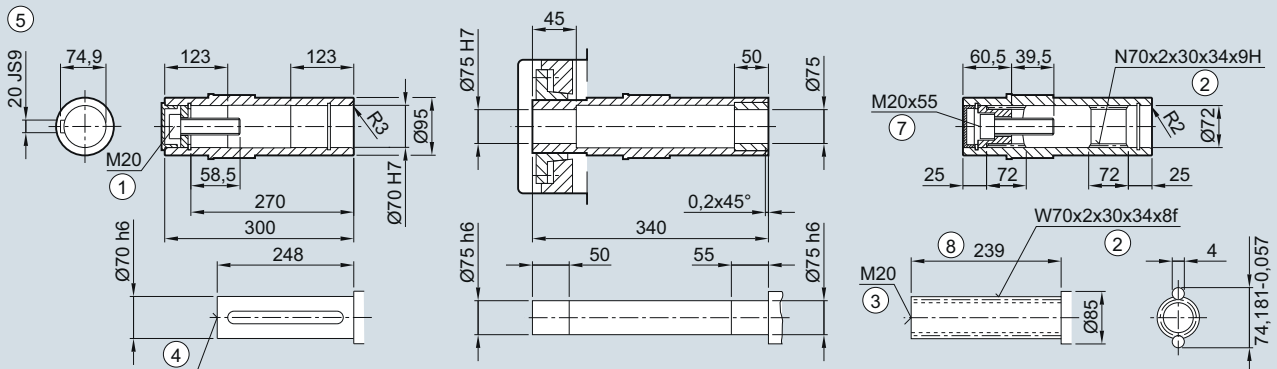
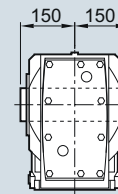
Dimensions**K.Z.129 in a housing flange design****KZ030KQ, KAZ030KQ, KAZS030KQ, KAZT030KQ****K129****KA129****KAS129****KAT129**

Adapter	a5	b5	c5	f5	e5	s5	z12	d5/D	E	F	GA	k
706	126.0	110	12	4.5	130	M8	15.0	24	50	8	27.0	575.5
708	155.0	130	15	4.5	165	M10	23.5	32	58	10	35.0	613.0
710	192.5	180	15	5.0	215	M12	33.0	38	80	10	41.0	682.0

① ISO 4014

② DIN 5480

③ DIN 332-D

④ DIN 332

⑤ Feather key/keyway DIN 6885

⑥ ISO 4762

⑧ Without locating shoulder +1 mm

⑨ For pin holes, see 4/131

⑩ Use bores only for foot-mounted design

KAD.129 gearbox in a shaft-mounted design

KAD030KQ, KADS030KQ, KADT030KQ

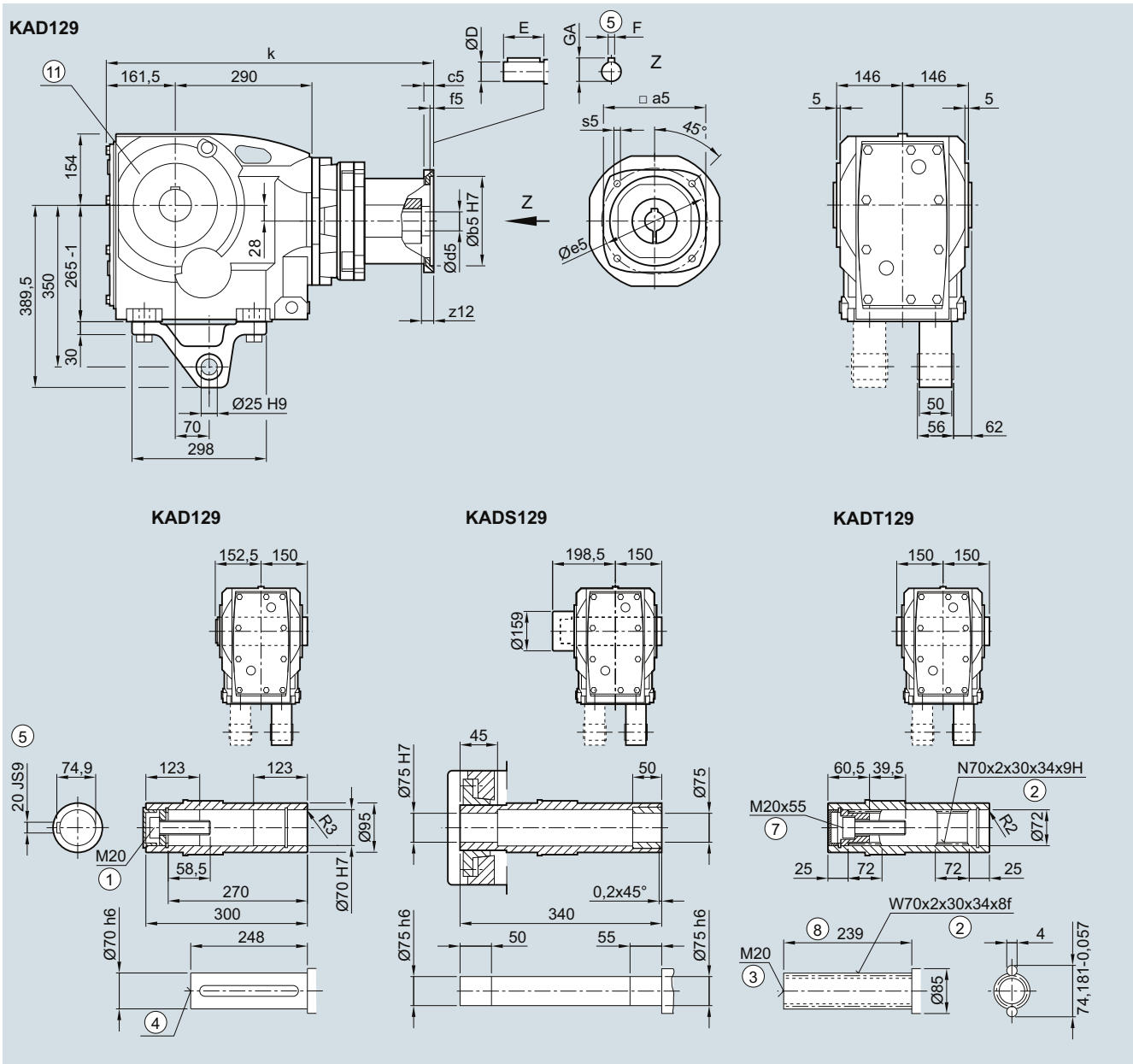

5

Adapter	a5	b5	c5	f5	e5	s5	z12	d5/D	E	F	GA	k
706	126.0	110	12	4.5	130	M8	15.0	24	50	8	27.0	575.5
708	155.0	130	15	4.5	165	M10	23.5	32	58	10	35.0	613.0
710	192.5	180	15	5.0	215	M12	33.0	38	80	10	41.0	682.0

- ① ISO 4014
- ② DIN 5480
- ③ DIN 332-D
- ④ DIN 332
- ⑤ Feather key/keyway DIN 6885
- ⑥ ISO 4762
- ⑦ Without locating shoulder +1 mm
- ⑧ Use bores only for housing flange design

SIMOGEAR Gearboxes

Bevel gearbox with adapter KQ

Dimensions

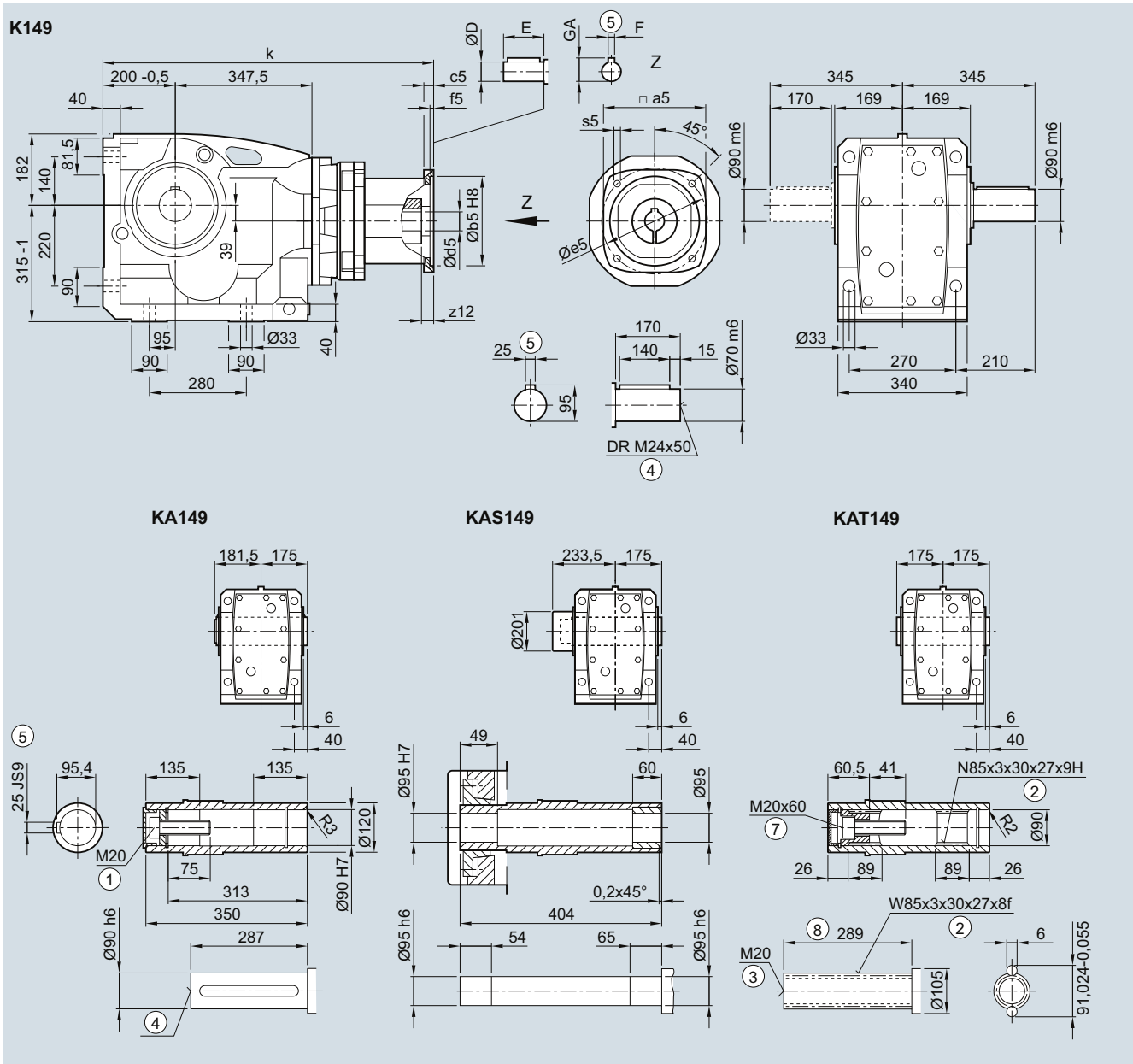
K.149 gearbox in a foot-mounted design**K030KQ, KA030KQ, KAS030KQ, KAT030KQ**

Adapter	a5	b5	c5	f5	e5	s5	z12	d5/D	E	F	GA	k
706	126.0	110	12	4.5	130	M8	15.0	24	50	8	27.0	664.5
708	155.0	130	15	4.5	165	M10	23.5	32	58	10	35.0	700.0
710	192.5	180	15	5.0	215	M12	33.0	38	80	10	41.0	767.0

(1) ISO 4014 (2) DIN 5480 (3) DIN 332-D (4) DIN 332 (5) Feather key/keyway DIN 6885 (7) ISO 4762 (8) Without locating shoulder +1 mm

K.F.149 gearbox in a flange-mounted design

KF030KQ, KAF030KQ, KAFS030KQ, KAFT030KQ

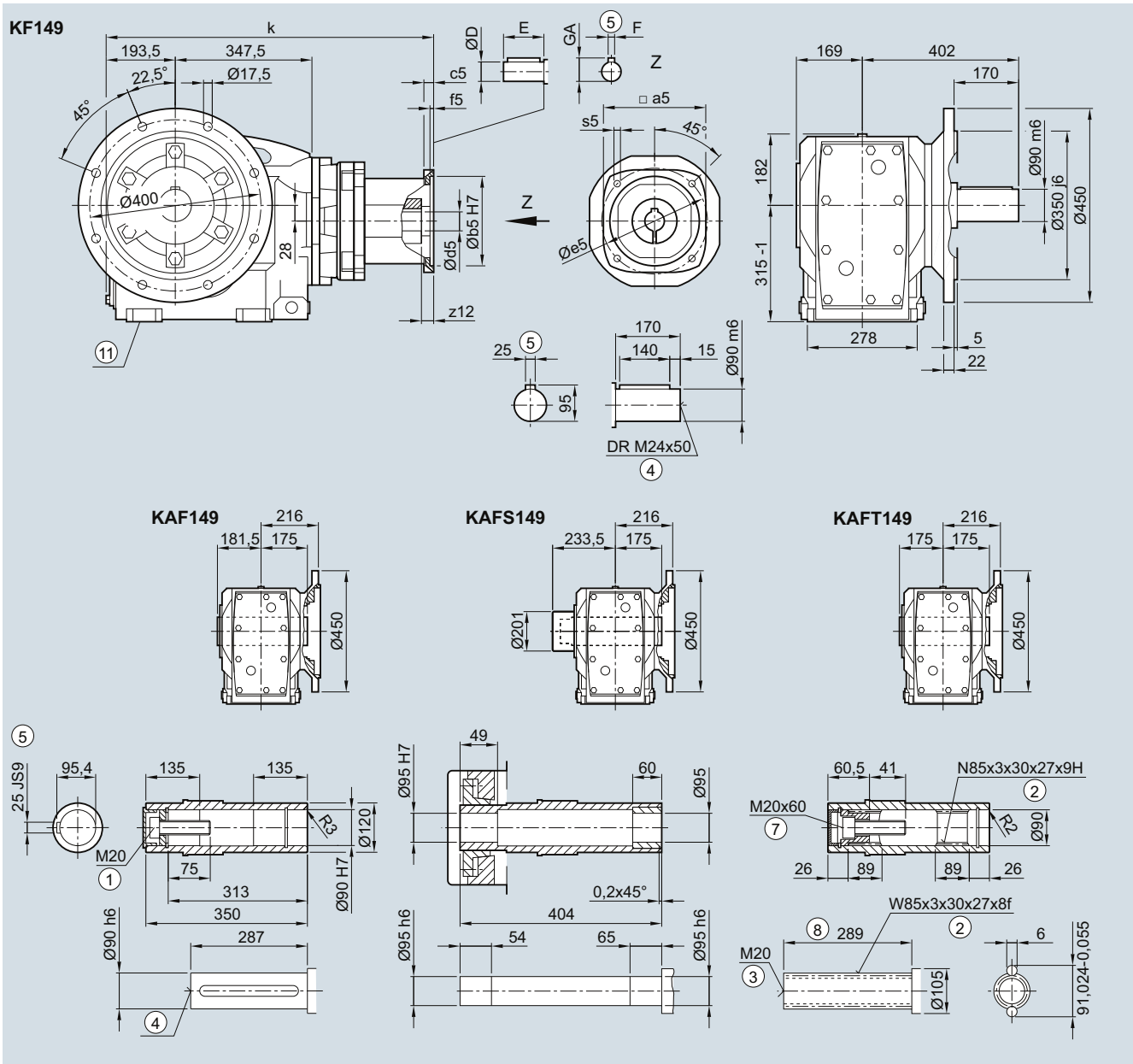

5

Adapter	a5	b5	c5	f5	e5	s5	z12	d5/D	E	F	GA	k
706	126.0	110	12	4.5	130	M8	15.0	24	50	8	27.0	658.0
708	155.0	130	15	4.5	165	M10	23.5	32	58	10	35.0	693.5
710	192.5	180	15	5.0	215	M12	33.0	38	80	10	41.0	760.5

- ① ISO 4014 ② DIN 5480 ③ DIN 332-D ④ DIN 332 ⑤ Feather key/keyway DIN 6885
- ⑦ ISO 4762 ⑧ Without locating shoulder +1 mm ⑨ Use bores only for foot-mounted design

SIMOGEAR Gearboxes

Bevel gearbox with adapter KQ

Dimensions

K.Z.149 in a housing flange design

KZ030KQ, KAZ030KQ, KAZS030KQ, KAZT030KQ

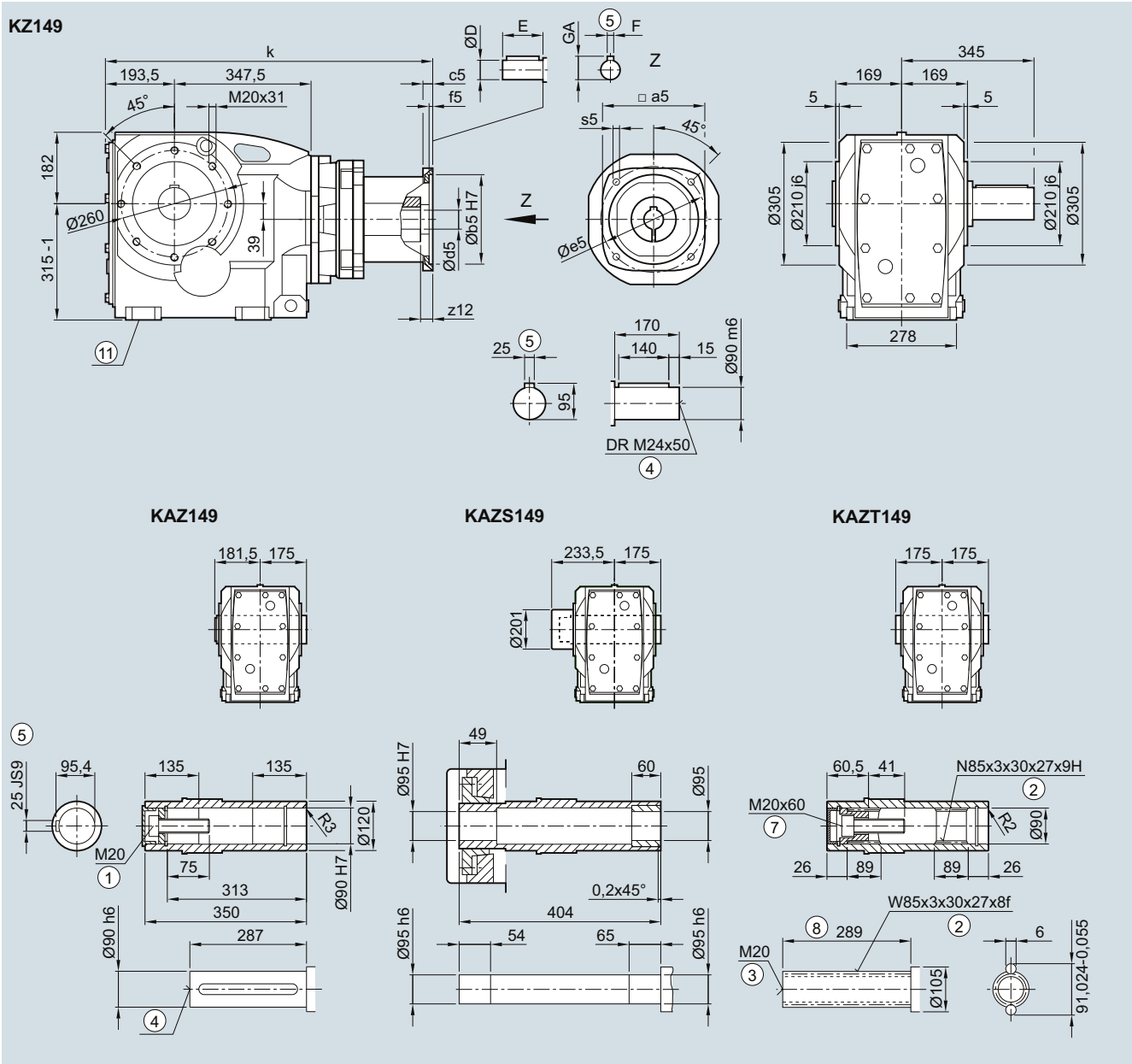

Adapter	a5	b5	c5	f5	e5	s5	z12	d5/D	E	F	GA	k
706	126.0	110	12	4.5	130	M8	15.0	24	50	8	27.0	658.0
708	155.0	130	15	4.5	165	M10	23.5	32	58	10	35.0	693.5
710	192.5	180	15	5.0	215	M12	33.0	38	80	10	41.0	760.5

- ① ISO 4014
- ② DIN 5480
- ③ DIN 332-D
- ④ DIN 332
- ⑤ Feather key/keyway DIN 6885
- ⑥ ISO 4762
- ⑦ Without locating shoulder +1 mm
- ⑧ Use bores only for foot-mounted design

KAD.149 gearbox in a shaft-mounted design

KAD030KQ, KADS030KQ, KADT030KQ

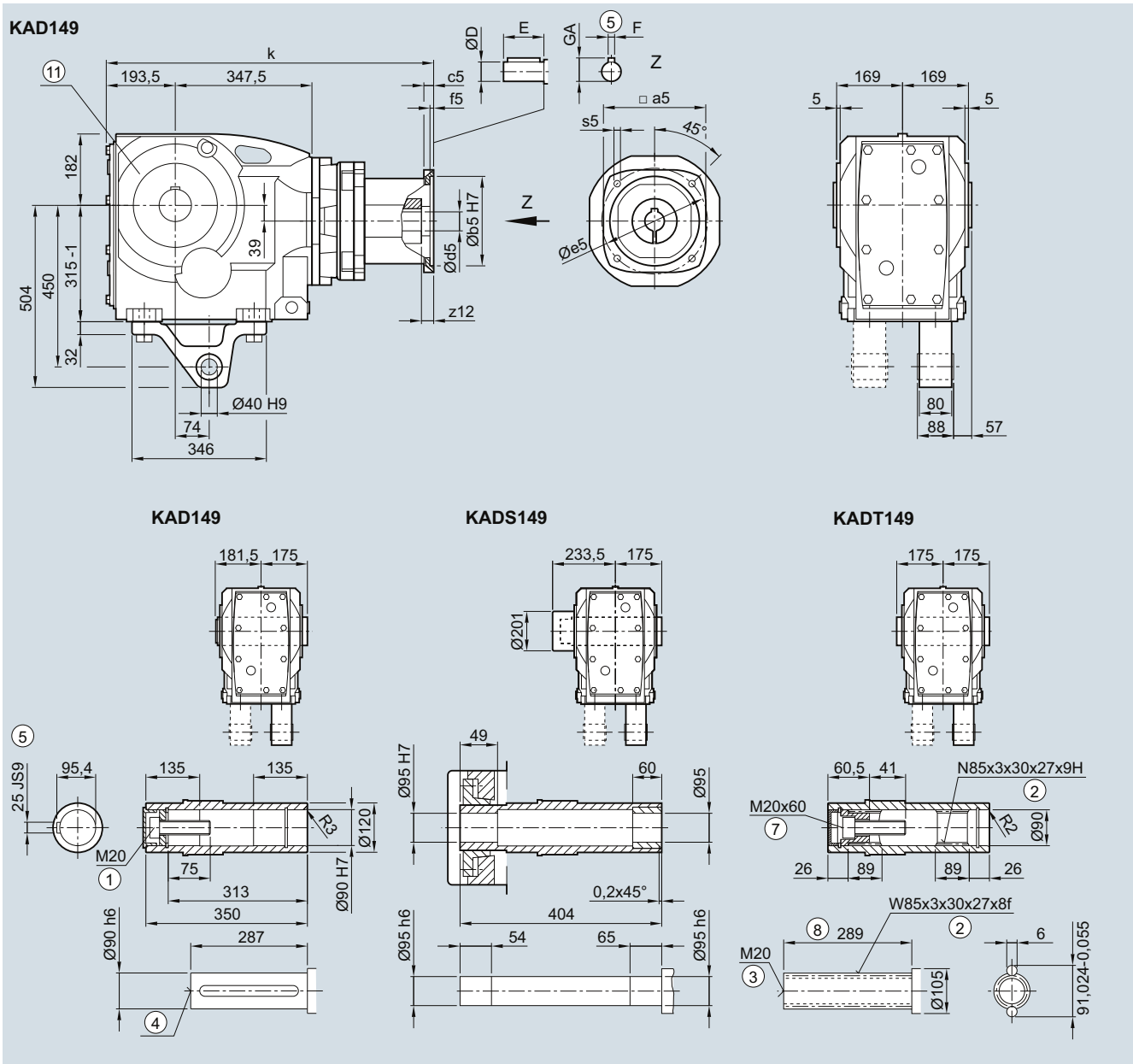

Adapter	a5	b5	c5	f5	e5	s5	z12	d5/D	E	F	GA	k
706	126.0	110	12	4.5	130	M8	15.0	24	50	8	27.0	658.0
708	155.0	130	15	4.5	165	M10	23.5	32	58	10	35.0	693.5
710	192.5	180	15	5.0	215	M12	33.0	38	80	10	41.0	760.5

- ① ISO 4014
- ② DIN 5480
- ③ DIN 332-D
- ④ DIN 332
- ⑤ Feather key/keyway DIN 6885
- ⑥ ISO 4762
- ⑦ Without locating shoulder +1 mm
- ⑧ Use bores only for housing flange design

SIMOGEAR Gearboxes

Bevel gearbox with adapter KQ

Dimensions

K.169 gearbox in a foot-mounted design

K030KQ, KA030KQ, KAS030KQ, KAT030KQ

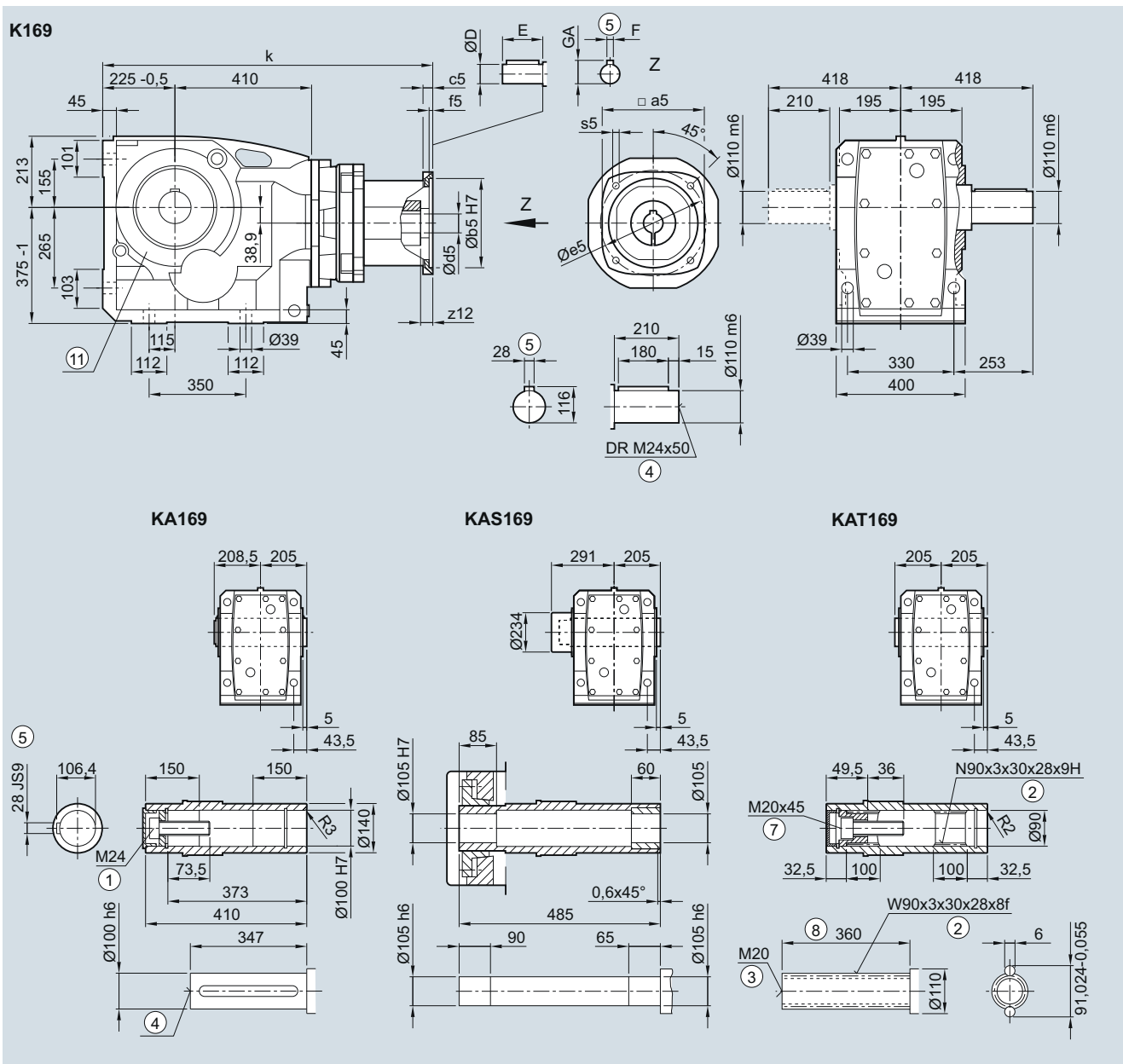

KA169

KAS169

KAT169

Adapter	a5	b5	c5	f5	e5	s5	z12	d5/D	E	F	GA	k
708	155.0	130	15	4.5	165	M10	23.5	32	58	10	35.0	786.0
710	192.5	180	15	5.0	215	M12	33.0	38	80	10	41.0	848.0

- ① ISO 4014
- ② DIN 5480
- ③ DIN 332-D
- ④ DIN 332
- ⑤ Feather key/keyway DIN 6885
- ⑥ ISO 4762
- ⑦ Without locating shoulder +1 mm
- ⑧ Use bores only for housing flange design

K.F.169 gearbox in a flange-mounted design

KF030KQ, KAF030KQ, KAFS030KQ, KAFT030KQ

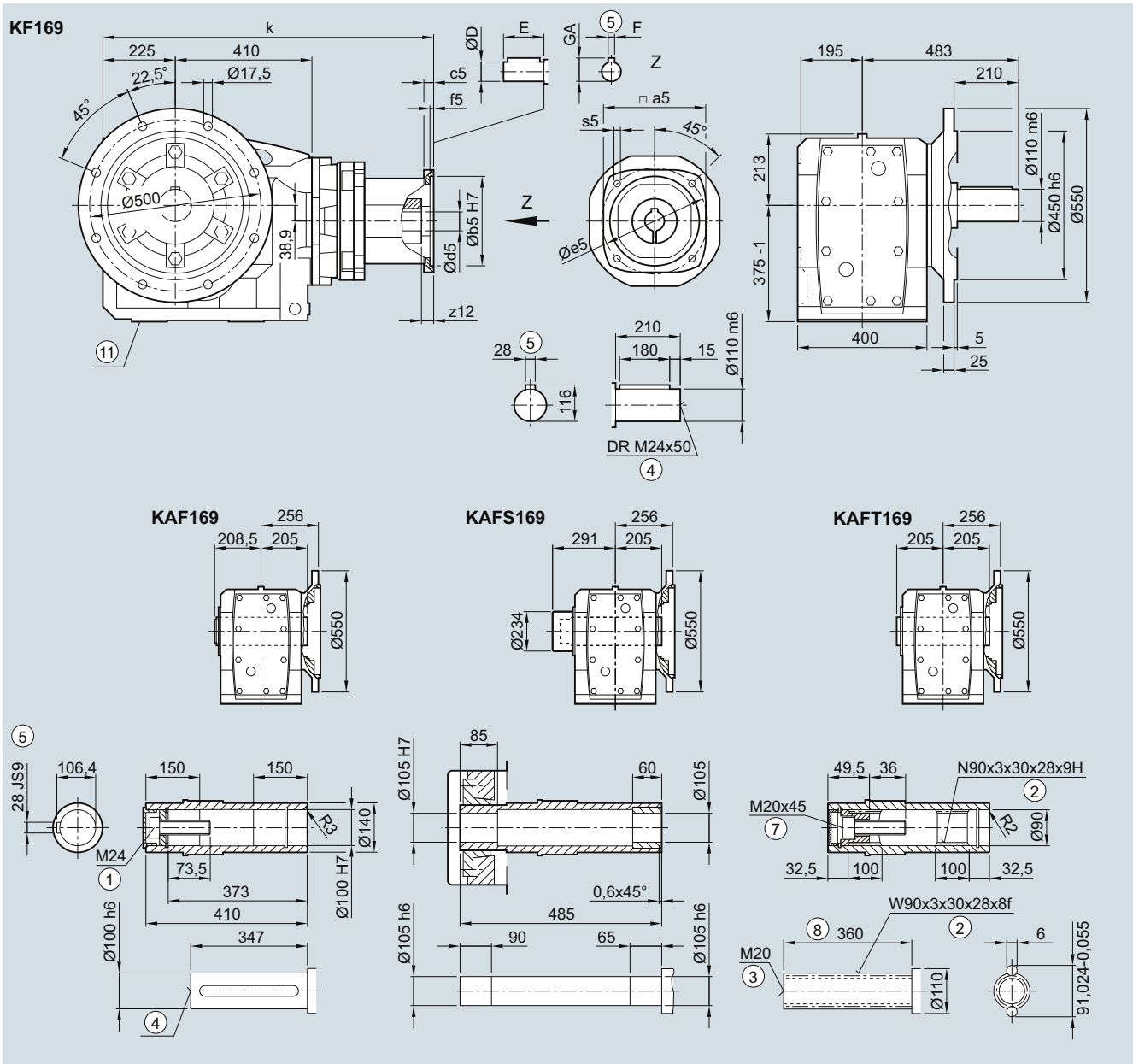

Adapter	a5	b5	c5	f5	e5	s5	z12	d5/D	E	F	GA	k
708	155.0	130	15	4.5	165	M10	23.5	32	58	10	35.0	786.0
710	192.5	180	15	5.0	215	M12	33.0	38	80	10	41.0	848.0

① ISO 4014 ② DIN 5480 ③ DIN 332-D ④ DIN 332 ⑤ Feather key/keyway DIN 6885
 ⑦ ISO 4762 ⑧ Without locating shoulder +1 mm ⑨ Use bores only for foot-mounted design

SIMOGEAR Gearboxes

Bevel gearbox with adapter KQ

Dimensions

K.Z.169 gearbox in a housing flange design

KZ030KQ, KAZ030KQ, KAZS030KQ, KAZT030KQ

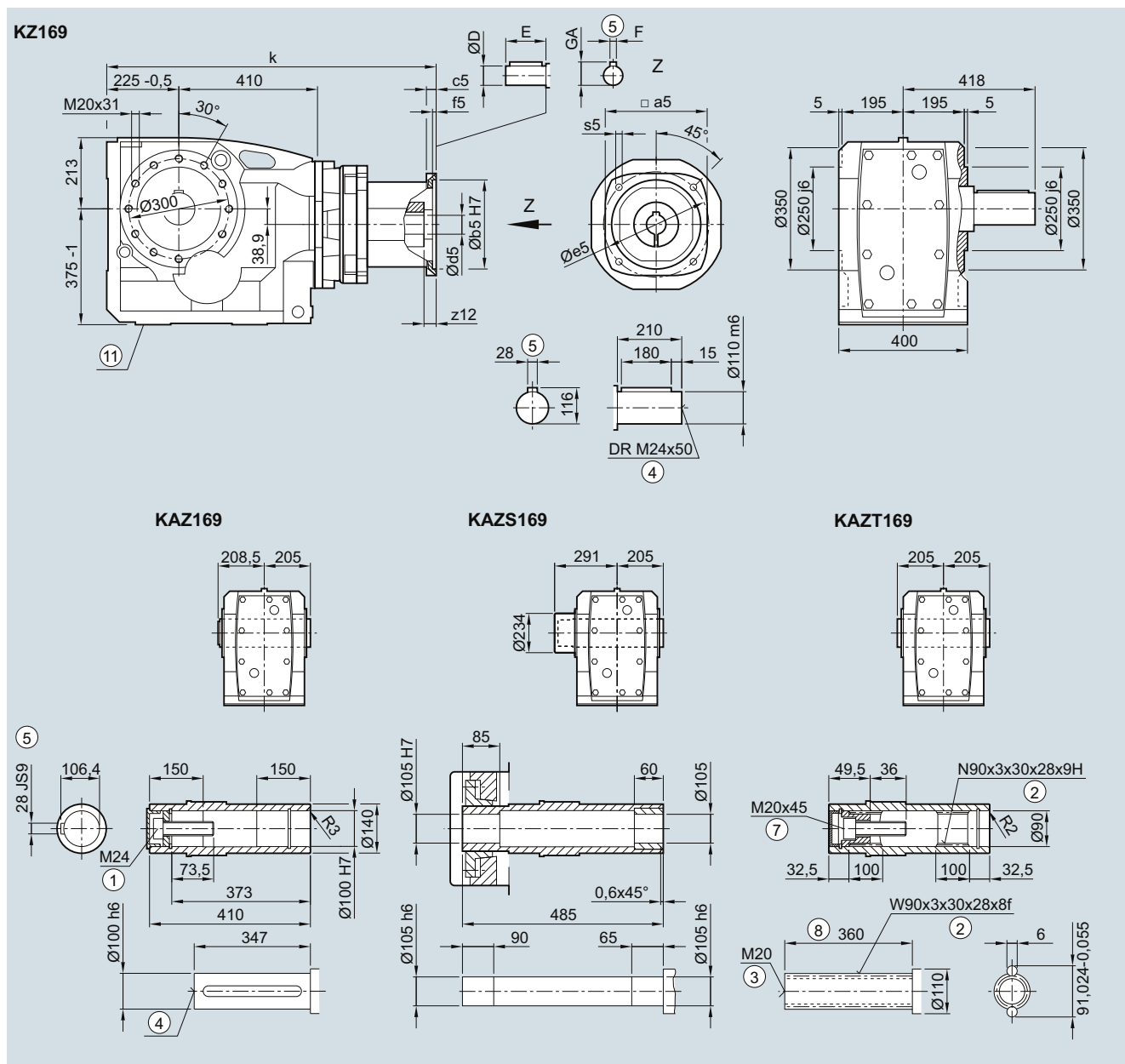

Adapter	a5	b5	c5	f5	e5	s5	z12	d5/D	E	F	GA	k
708	155.0	130	15	4.5	165	M10	23.5	32	58	10	35.0	786.0
710	192.5	180	15	5.0	215	M12	33.0	38	80	10	41.0	848.0

- ① ISO 4014 ② DIN 5480 ③ DIN 332-D ④ DIN 332 ⑤ Feather key/keyway DIN 6885
- ⑦ ISO 4762 ⑧ Without locating shoulder +1 mm ⑨ Use bores only for foot-mounted design

KAD.169 gearbox in a shaft-mounted design

KAD030KQ, KADS030KQ, KADT030KQ

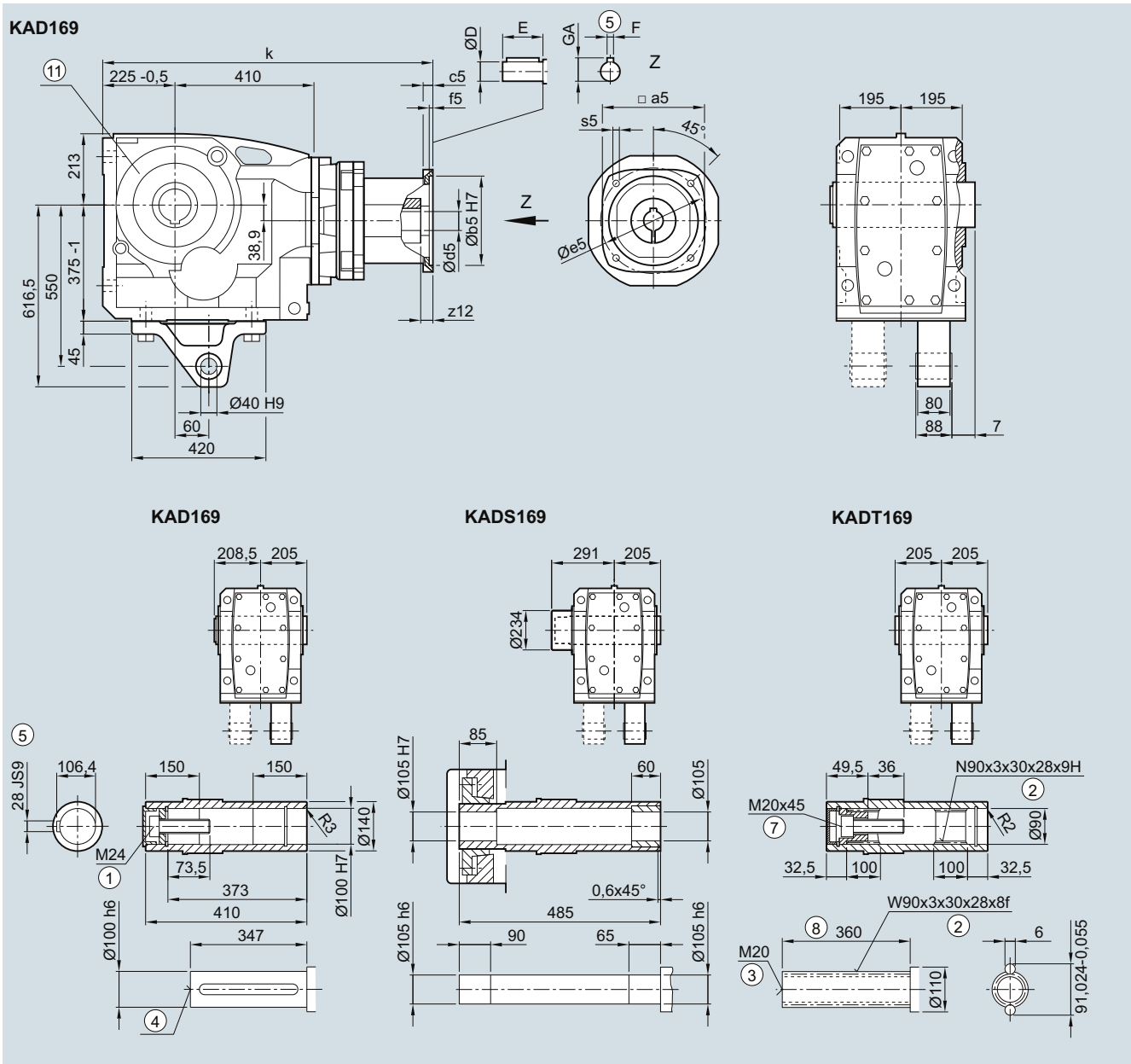

5

Adapter	a5	b5	c5	f5	e5	s5	z12	d5/D	E	F	GA	k
708	155.0	130	15	4.5	165	M10	23.5	32	58	10	35.0	786.0
710	192.5	180	15	5.0	215	M12	33.0	38	80	10	41.0	848.0

- ① ISO 4014
- ② DIN 5480
- ③ DIN 332-D
- ④ DIN 332
- ⑤ Feather key/keyway DIN 6885
- ⑥ ISO 4762
- ⑦ Without locating shoulder +1 mm
- ⑧ Use bores only for housing flange design

SIMOGEAR Gearboxes

Bevel gearbox with adapter KQ

Dimensions

K.189 gearbox in a foot-mounted design

K030KQ, KA030KQ, KAS030KQ, KAT030KQ

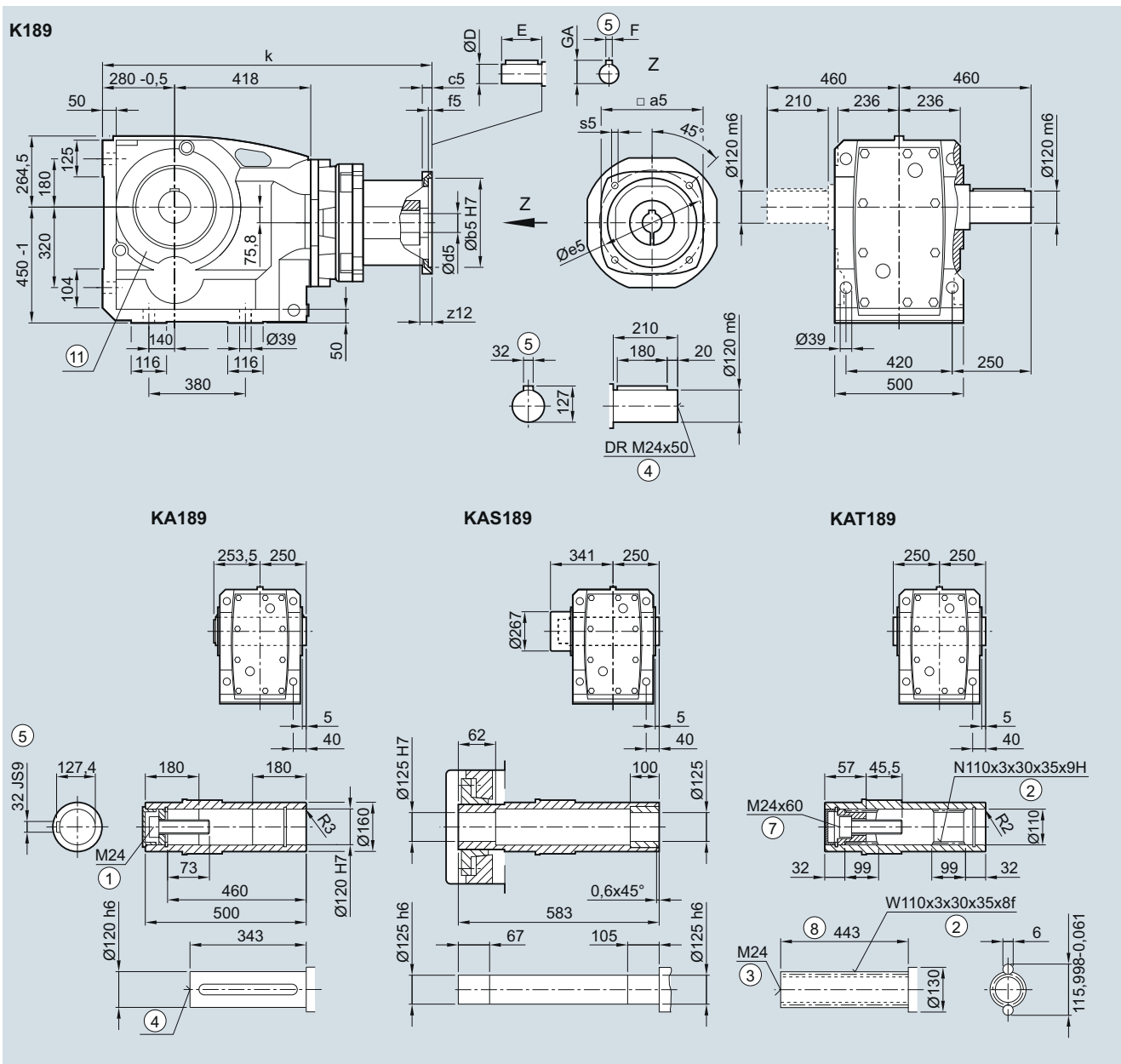

Adapter	a5	b5	c5	f5	e5	s5	z12	d5/D	E	F	GA	k
708	155.0	130	15	4.5	165	M10	23.5	32	58	10	35.0	836.5
710	192.5	180	15	5.0	215	M12	33.0	38	80	10	41.0	848.0

- ① ISO 4014 ② DIN 5480 ③ DIN 332-D ④ DIN 332 ⑤ Feather key/keyway DIN 6885
- ⑦ ISO 4762 ⑧ Without locating shoulder +1 mm ⑥ Use bores only for housing flange design

K.F.189 gearbox in a flange-mounted design

KF030KQ, KAF030KQ, KAFS030KQ, KAFT030KQ

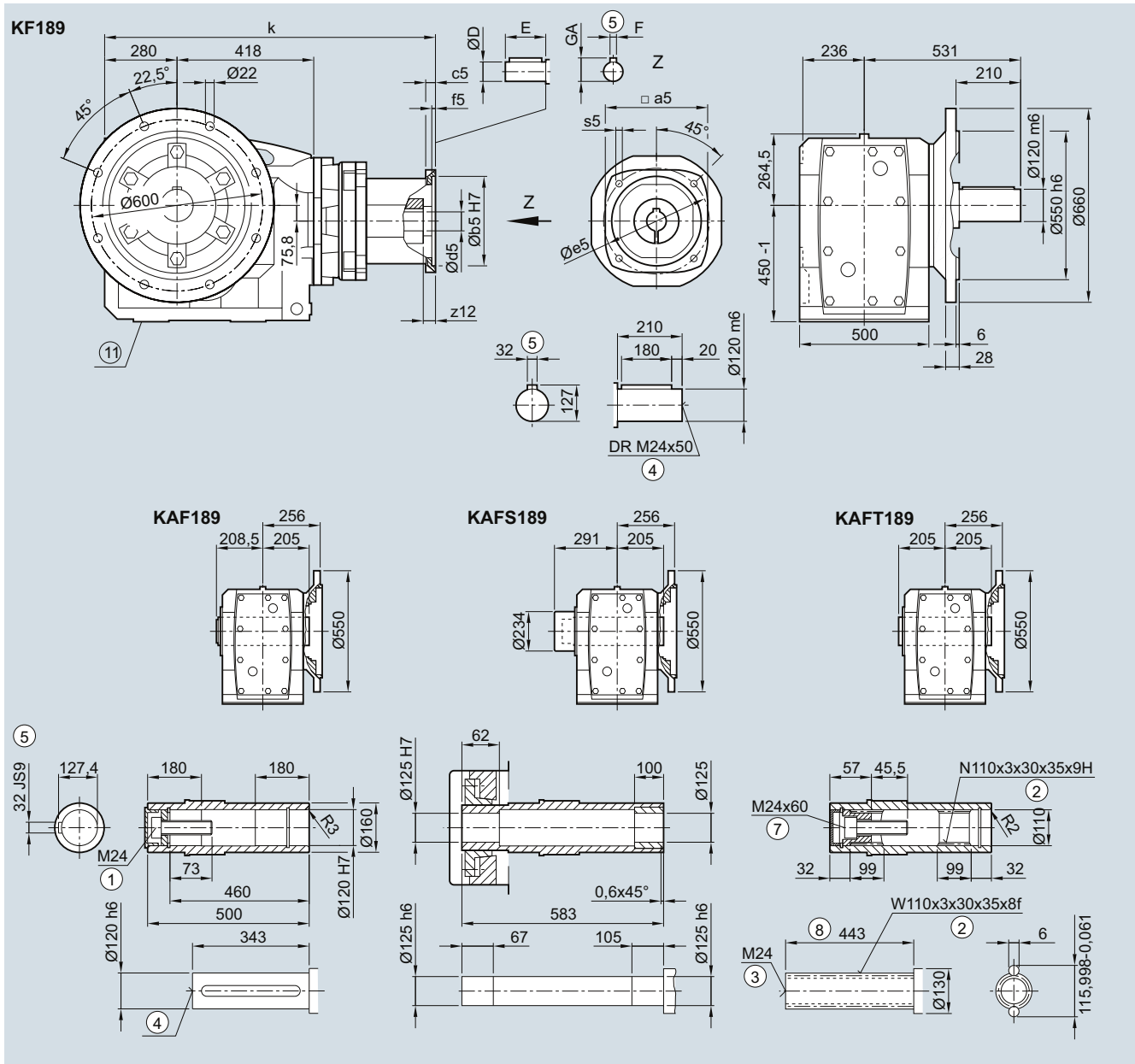

5

Adapter	a5	b5	c5	f5	e5	s5	z12	d5/D	E	F	GA	k
708	155.0	130	15	4.5	165	M10	23.5	32	58	10	35.0	836.5
710	192.5	180	15	5.0	215	M12	33.0	38	80	10	41.0	848.0

- ① ISO 4014
- ② DIN 5480
- ③ DIN 332-D
- ④ DIN 332
- ⑤ Feather key/keyway DIN 6885
- ⑥ ISO 4762
- ⑦ Without locating shoulder +1 mm
- ⑧ Use bores only for foot-mounted design

SIMOGEAR Gearboxes

Bevel gearbox with adapter KQ

Dimensions

K.Z.189 gearbox in a housing flange design

KZ030KQ, KAZ030KQ, KAZS030KQ, KAZT030KQ

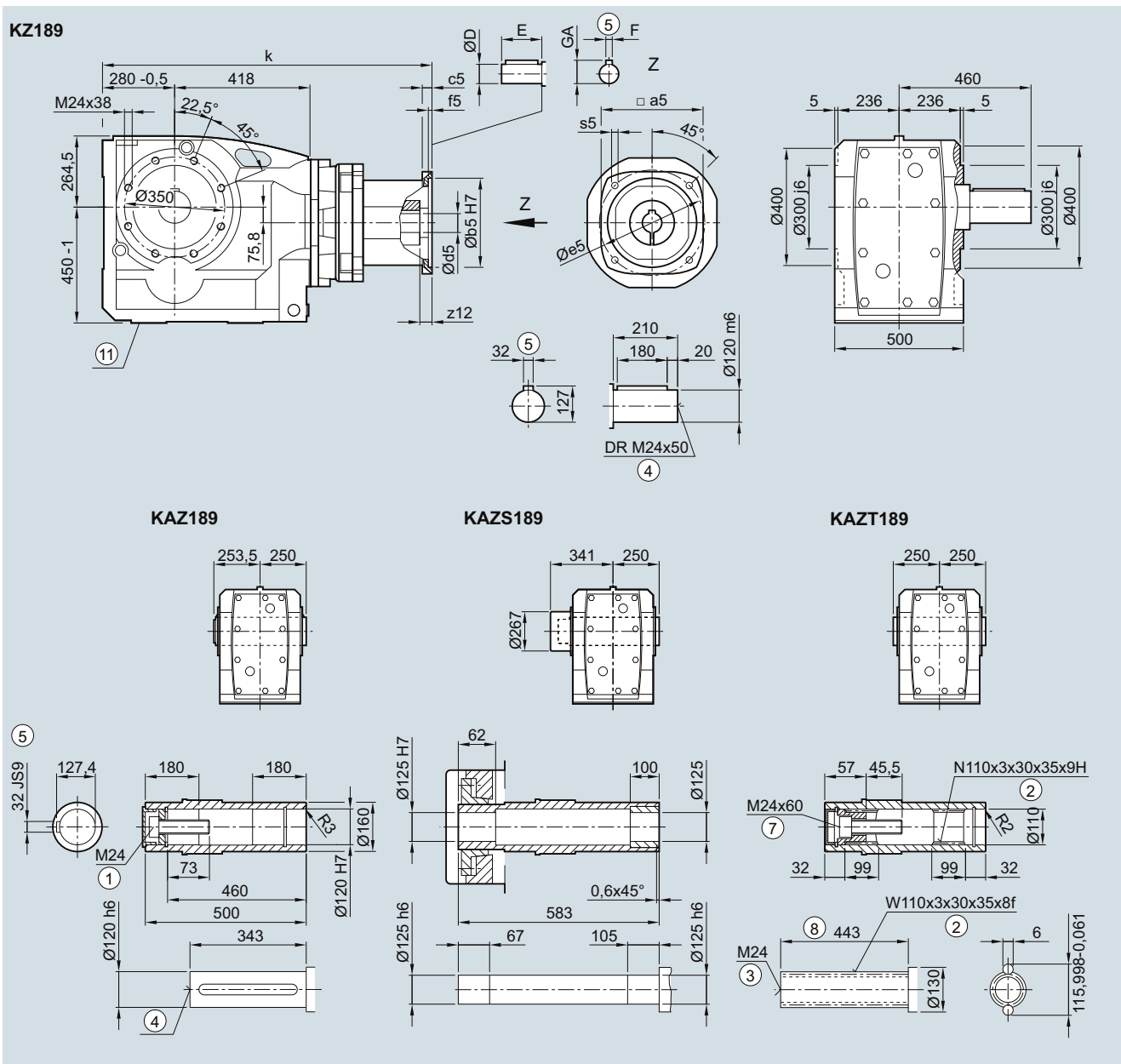

Adapter	a5	b5	c5	f5	e5	s5	z12	d5/D	E	F	GA	k
708	155.0	130	15	4.5	165	M10	23.5	32	58	10	35.0	836.5
710	192.5	180	15	5.0	215	M12	33.0	38	80	10	41.0	848.0

- ① ISO 4014 ② DIN 5480 ③ DIN 332-D ④ DIN 332 ⑤ Feather key/keyway DIN 6885
- ⑦ ISO 4762 ⑧ Without locating shoulder +1 mm ⑨ Use bores only for foot-mounted design

KAD.189 gearbox in a shaft-mounted design

KAD030KQ, KADS030KQ, KADT030KQ

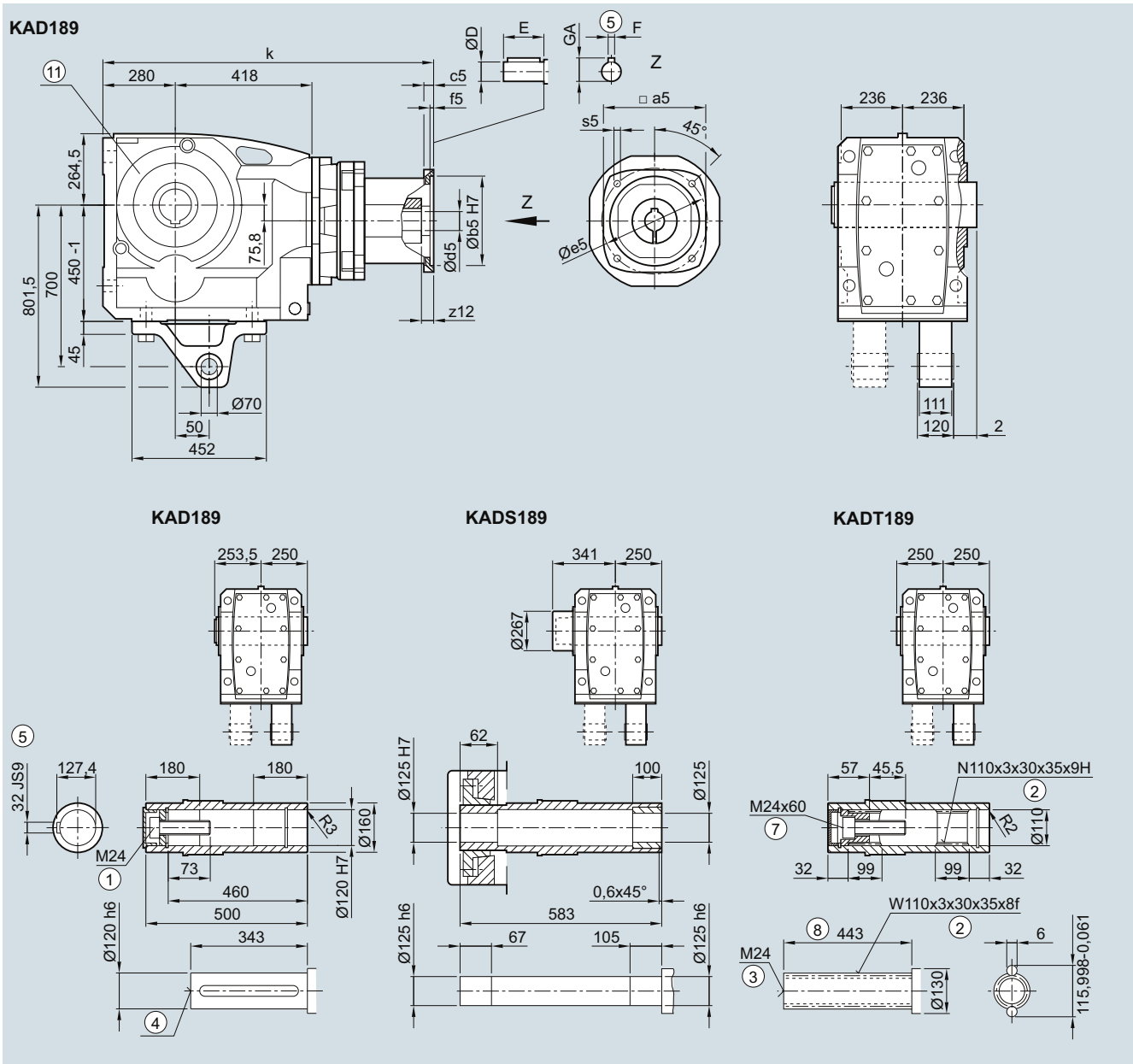

5

Adapter	a5	b5	c5	f5	e5	s5	z12	d5/D	E	F	GA	k
708	155.0	130	15	4.5	165	M10	23.5	32	58	10	35.0	836.5
710	192.5	180	15	5.0	215	M12	33.0	38	80	10	41.0	848.0

- ① ISO 4014
- ② DIN 5480
- ③ DIN 332-D
- ④ DIN 332
- ⑤ Feather key/keyway DIN 6885
- ⑥ ISO 4762
- ⑦ Without locating shoulder +1 mm
- ⑧ Use bores only for housing flange design

SIMOGEAR Gearboxes

Bevel gearbox with adapter QQS

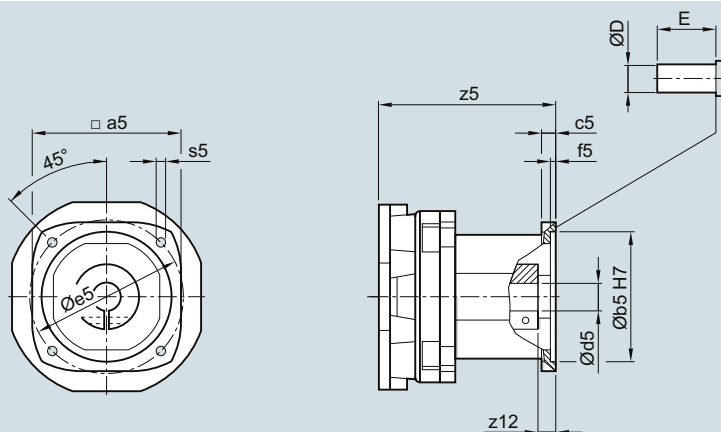
Dimensions**B...29 to B...49 and K...39 to K...69 gearboxes****B..030KQS, B.F.030KQS, B.Z.030KQS, BAD.030KQS
K..030KQS, K.F.030KQS, K.Z.030K, KAD.030KQS**

5

Adapter	a5	b5	c5	f5	e5	s5	z12	d5/D	E	z5
B...29										
703	71.6	60	9	4.0	75	M5	18.0	14	30	99.5
704	96.5	80	10	4.0	100	M6	14.0	19	40	146.5
706	126.0	110	12	4.5	130	M8	15.0	24	50	159.5
B...39										
703	71.6	60	9	4.0	75	M5	18.0	14	30	99.5
704	96.5	80	10	4.0	100	M6	14.0	19	40	146.5
706	126.0	110	12	4.5	130	M8	15.0	24	50	159.5
708	155.0	130	15	4.5	165	M10	23.5	32	58	203.0
B...49										
703	71.6	60	9	4.0	75	M5	18.0	14	30	90.0
704	96.5	80	10	4.0	100	M6	14.0	19	40	137.0
706	126.0	110	12	4.5	130	M8	15.0	24	50	150.0
708	155.0	130	15	4.5	165	M10	23.5	32	58	193.5
710	192.5	180	15	5.0	215	M12	33.0	38	80	262.5
K...39										
703	71.6	60	9	4.0	75	M5	18.0	14	30	99.5
704	96.5	80	10	4.0	100	M6	14.0	19	40	146.5
706	126.0	110	12	4.5	130	M8	15.0	24	50	159.5
708	155.0	130	15	4.5	165	M10	23.5	32	58	203.0
K...49										
703	71.6	60	9	4.0	75	M5	18.0	14	30	90.0
704	96.5	80	10	4.0	100	M6	14.0	19	40	137.0
706	126.0	110	12	4.5	130	M8	15.0	24	50	150.0
708	155.0	130	15	4.5	165	M10	23.5	32	58	193.5
710	192.5	180	15	5.0	215	M12	33.0	38	80	262.5
K...69										
703	71.6	60	9	4.0	75	M5	18.0	14	30	90.0
704	96.5	80	10	4.0	100	M6	14.0	19	40	137.0
706	126.0	110	12	4.5	130	M8	15.0	24	50	150.0
708	155.0	130	15	4.5	165	M10	23.5	32	58	193.5
710	192.5	180	15	5.0	215	M12	33.0	38	80	262.5

K...79 to K...189 gearboxes

K...030KQS, K.F.030KQS, K.Z.030K, KAD.030KQS

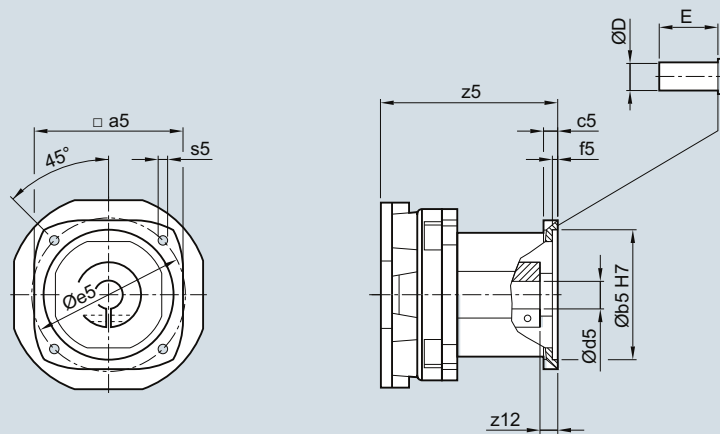

Adapter	a5	b5	c5	f5	e5	s5	z12	d5/D	E	z5
K...79										
703	71.6	60	9	4.0	75	M5	18.0	14	30	90.0
704	96.5	80	10	4.0	100	M6	14.0	19	40	137.0
706	126.0	110	12	4.5	130	M8	15.0	24	50	150.0
708	155.0	130	15	4.5	165	M10	23.5	32	58	193.5
710	192.5	180	15	5.0	215	M12	33.0	38	80	262.5
K...89										
703	71.6	60	9	4.0	75	M5	18.0	14	30	88.0
704	96.5	80	10	4.0	100	M6	14.0	19	40	131.0
706	126.0	110	12	4.5	130	M8	15.0	24	50	144.0
708	155.0	130	15	4.5	165	M10	23.5	32	58	187.5
710	192.5	180	15	5.0	215	M12	33.0	38	80	256.5
K...109										
704	96.5	80	10	4.0	100	M6	14.0	19	40	118.0
706	126.0	110	12	4.5	130	M8	15.0	24	50	131.0
708	155.0	130	15	4.5	165	M10	23.5	32	58	170.5
710	192.5	180	15	5.0	215	M12	33.0	38	80	239.5
K...129										
706	126.0	110	12	4.5	130	M8	15.0	24	50	124.0
708	155.0	130	15	4.5	165	M10	23.5	32	58	161.5
710	192.5	180	15	5.0	215	M12	33.0	38	80	230.5
K...149										
706	126.0	110	12	4.5	130	M8	15.0	24	50	117.0
708	155.0	130	15	4.5	165	M10	23.5	32	58	152.5
710	192.5	180	15	5.0	215	M12	33.0	38	80	219.5
K...169										
708	155.0	130	15	4.5	165	M10	23.5	32	58	151.0
710	192.5	180	15	5.0	215	M12	33.0	38	80	213.0
K...189										
708	155.0	130	15	4.5	165	M10	23.5	32	58	138.5
710	192.5	180	15	5.0	215	M12	33.0	38	80	200.0

SIMOGEAR Gearboxes

Bevel gearbox with adapter K8

Dimensions**B...39 to B...49 and K...39 to K...109 gearboxes**

B..030K8, B.F.030K8, B.Z.030K8, BAD.030K8
K..030K8, K.F.030K8, K.Z.030K8, KAD.030K8

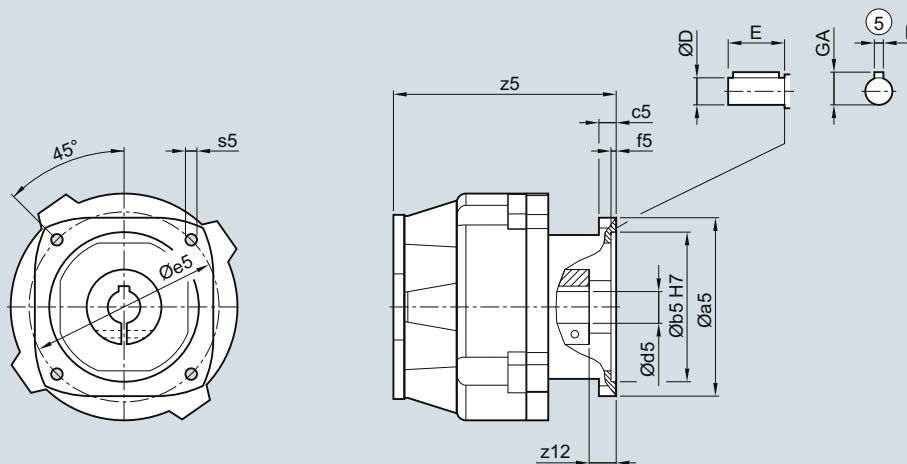

5

Adapter	a5	b5	c5	f5	e5	s5	z12	d5/D	E	F	GA	z5
B...39												
808	155.0	130	35	4.5	165	M10	43.5	32	80	10	35.0	223.0
B...49												
808	155.0	130	35	4.5	165	M10	43.5	32	80	10	35.0	213.5
810	192.5	180	15	5.0	215	M12	33.0	38	80	10	41.0	262.5
K...39												
808	155.0	130	35	4.5	165	M10	43.5	32	80	10	35.0	223.0
K...49												
808	155.0	130	35	4.5	165	M10	43.5	32	80	10	35.0	213.5
810	192.5	180	15	5.0	215	M12	33.0	38	80	10	41.0	262.5
K...69												
808	155.0	130	35	4.5	165	M10	43.5	32	80	10	35.0	213.5
810	192.5	180	15	5.0	215	M12	33.0	38	80	10	41.0	262.5
K...79												
808	155.0	130	35	4.5	165	M10	43.5	32	80	10	35.0	213.5
810	192.5	180	15	5.0	215	M12	33.0	38	80	10	41.0	262.5
K...89												
808	155.0	130	35	4.5	165	M10	43.5	32	80	10	35.0	207.5
810	192.5	180	15	5.0	215	M12	33.0	38	80	10	41.0	256.5
K...109												
808	155.0	130	35	4.5	165	M10	43.5	32	80	10	35.0	190.5
810	192.5	180	15	5.0	215	M12	33.0	38	80	10	41.0	239.5
813	260.0	250	25	6.0	300	M16	60.0	48	110	14	51.5	317.5

© Feather key/keyway DIN 6885

K...129 to K...189 gearboxes

K..030K8, K.F.030K8, K.Z.030K8, KAD.030K8

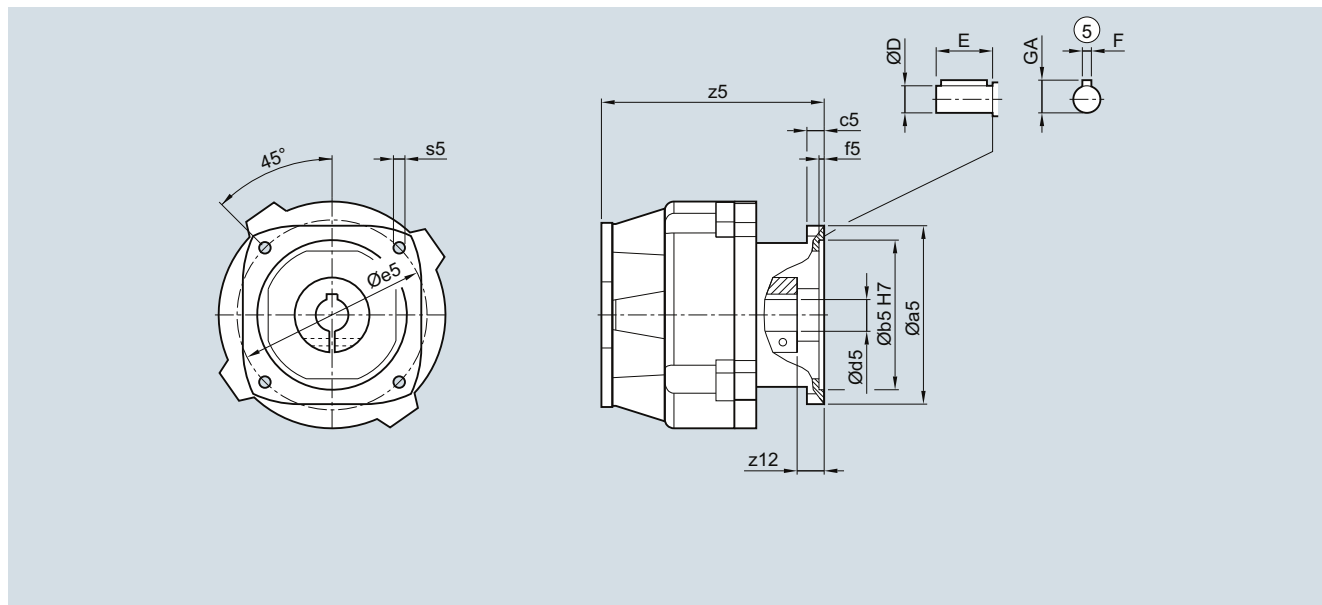

Adapter	a5	b5	c5	f5	e5	s5	z12	d5/D	E	F	GA	z5
K...129												
808	155.0	130	35	4.5	165	M10	43.5	32	80	10	35.0	181.5
810	192.5	180	15	5.0	215	M12	33.0	38	80	10	41.0	230.5
813	260.0	250	25	6.0	300	M16	60.0	48	110	14	51.5	308.5
816	314.0	300	-	6.0	350	M16x29	60	55	110	16	59.0	365.0
K...149												
808	155.0	130	35	4.5	165	M10	43.5	32	80	10	35.0	172.5
810	192.5	180	15	5.0	215	M12	33.0	38	80	10	41.0	219.5
813	260.0	250	25	6.0	300	M16	60.0	48	110	14	51.5	297.5
816	314.0	300	-	6.0	350	M16x29	60	55	110	16	59.0	360.0
K...169												
808	155.0	130	35	4.5	165	M10	43.5	32	80	10	35.0	171.0
810	192.5	180	15	5.0	215	M12	33.0	38	80	10	41.0	213.0
813	260.0	250	25	6.0	300	M16	60.0	48	110	14	51.5	291.0
816	314.0	300	-	6.0	350	M16x29	60	55	110	16	59.0	347.5
818	550	350	22.0	12.0	400	M16	73	65	140	18	69.0	336.5
K...189												
808	155.0	130	35	4.5	165	M10	43.5	32	80	10	35.0	158.5
810	192.5	180	15	5.0	215	M12	33.0	38	80	10	41.0	200.0
813	260.0	250	25	6.0	300	M16	60.0	48	110	14	51.5	278.0
816	314.0	300	-	6.0	350	M16x29	60.0	55	110	16	59.0	333.0
818	550	350	22.0	12.0	400	M16	73.0	65	140	18	69.0	319.5
822	660	450	58.5	25.0	500	M16	58.5	75	140	20	79.5	346.5

⑤ Feather key/keyway DIN 6885

SIMOGEAR Gearboxes

Bevel gearbox with adapter K5

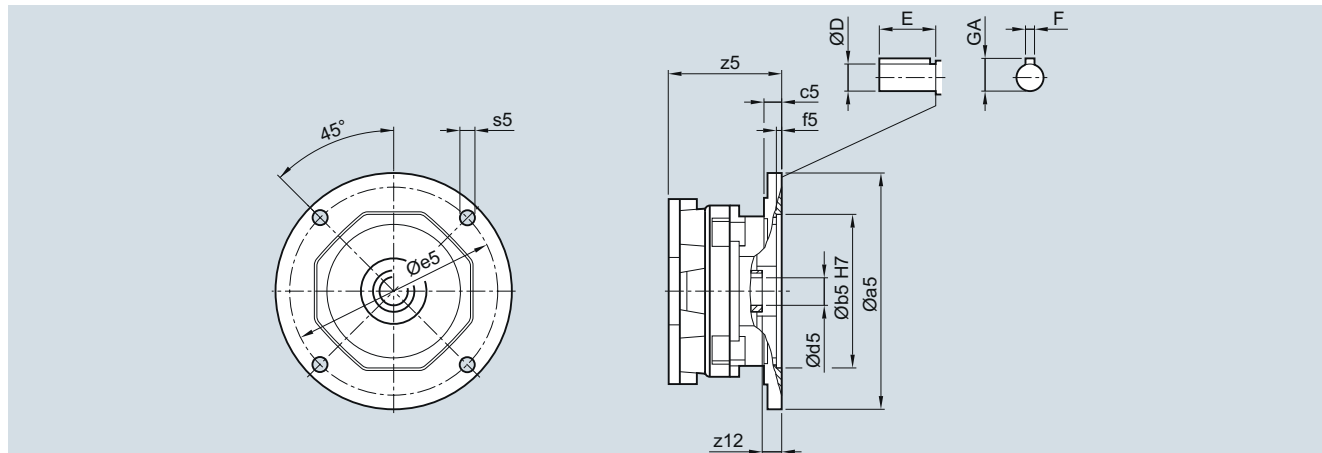
Dimensions**B...29 to B...49 and K...39 to K...89 gearboxes****B..030K5, B.F.030K5, B.Z.030K5, BAD.030K5
K..030K5, K.F.030K5, K.Z.030K5, KAD.030K5**

Adapter	a5	b5	c5	f5	e5	s5	z12	d5/D	E	F	GA	z5
B...29												
56	168	114.3	15	5.0	149.2	11.0	16	15.875	47.752	4.763	17.895	118.5
140	168	114.3	15	5.0	149.2	11.0	16	22.225	57.150	4.763	24.346	118.5
180	226	215.9	22	5.5	184.1	13.5	26	28.575	69.850	6.350	31.394	200.5
B...39												
56	168	114.3	15	5.0	149.2	11.0	16	15.875	47.752	4.763	17.895	118.5
140	168	114.3	15	5.0	149.2	11.0	16	22.225	57.150	4.763	24.346	118.5
180	226	215.9	22	5.5	184.1	13.5	26	28.575	69.850	6.350	31.394	200.5
B...49												
56	168	114.3	15	5.0	149.2	11.0	16	15.875	47.752	4.763	17.895	109.0
140	168	114.3	15	5.0	149.2	11.0	16	22.225	57.150	4.763	24.346	109.0
180	226	215.9	22	5.5	184.1	13.5	26	28.575	69.850	6.350	31.394	191.0
210	226	215.9	22	5.5	184.1	13.5	12	34.925	85.850	7.938	38.443	207.0
K...39												
56	168	114.3	15	5.0	149.2	11.0	16	15.875	47.752	4.763	17.895	118.5
140	168	114.3	15	5.0	149.2	11.0	16	22.225	57.150	4.763	24.346	118.5
180	226	215.9	22	5.5	184.1	13.5	26	28.575	69.850	6.350	31.394	200.5
K...49												
56	168	114.3	15	5.0	149.2	11.0	16	15.875	47.752	4.763	17.895	109.0
140	168	114.3	15	5.0	149.2	11.0	16	22.225	57.150	4.763	24.346	109.0
180	226	215.9	22	5.5	184.1	13.5	26	28.575	69.850	6.350	31.394	191.0
210	226	215.9	22	5.5	184.1	13.5	12	34.925	85.850	7.938	38.443	207.0
K...69												
56	168	114.3	15	5.0	149.2	11.0	16	15.875	47.752	4.763	17.895	109.0
140	168	114.3	15	5.0	149.2	11.0	16	22.225	57.150	4.763	24.346	109.0
180	226	215.9	22	5.5	184.1	13.5	26	28.575	69.850	6.350	31.394	191.0
210	226	215.9	22	5.5	184.1	13.5	12	34.925	85.850	7.938	38.443	207.0
K...79												
56	168	114.3	15	5.0	149.2	11.0	16	15.875	47.752	4.763	17.895	109.0
140	168	114.3	15	5.0	149.2	11.0	16	22.225	57.150	4.763	24.346	109.0
180	226	215.9	22	5.5	184.1	13.5	26	28.575	69.850	6.350	31.394	191.0
210	226	215.9	22	5.5	184.1	13.5	12	34.925	85.850	7.938	38.443	207.0
K...89												
56	168	114.3	15	5.0	149.2	11.0	16	15.875	47.752	4.763	17.895	103.0
140	168	114.3	15	5.0	149.2	11.0	16	22.225	57.150	4.763	24.346	103.0
180	226	215.9	22	5.5	184.1	13.5	26	28.575	69.850	6.350	31.394	185.0
210	226	215.9	22	5.5	184.1	13.5	12	34.925	85.850	7.938	38.443	201.0
250	226	215.9	22	5.5	184.1	13.5	12	41.275	101.600	9.525	45.491	201.0

K...109 to K...189 gearboxes

B..030K5, B.F.030K5, B.Z.030K5, BAD.030K5
K..030K5, K.F.030K5, K.Z.030K5, KAD.030K5

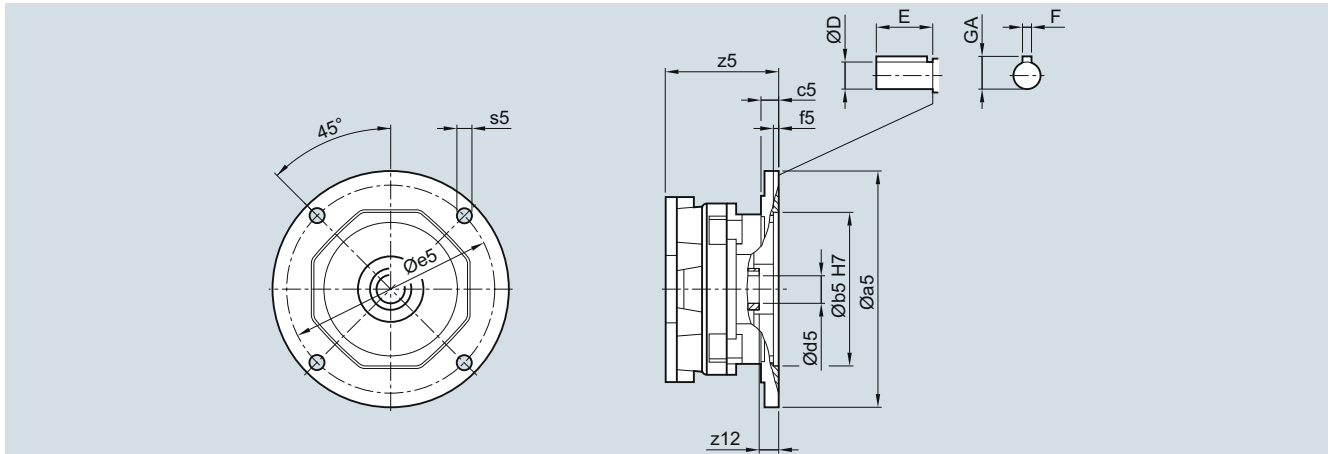

Adapter	a5	b5	c5	f5	e5	s5	z12	d5/D	E	F	GA	z5
K...109												
140	168	114.3	15	5.0	149.2	11.0	16	22.225	57.150	4.763	24.346	90.0
180	226	215.9	22	5.5	184.1	13.5	26	28.575	69.850	6.350	31.394	168.0
210	226	215.9	22	5.5	184.1	13.5	12	34.925	85.850	7.938	38.443	184.0
250	226	215.9	22	5.5	184.1	13.5	12	41.275	101.600	9.525	45.491	184.0
280	285	266.7	24.5	5.5	228.6	13.5	22	47.625	117.602	12.700	53.111	197.0
K...129												
140	168	114.3	15	5.0	149.2	11.0	16	22.225	57.150	4.763	24.346	90.0
180	226	215.9	22	5.5	184.1	13.5	26	28.575	69.850	6.350	31.394	168.0
210	226	215.9	22	5.5	184.1	13.5	12	34.925	85.850	7.938	38.443	184.0
250	226	215.9	22	5.5	184.1	13.5	12	41.275	101.600	9.525	45.491	184.0
280	285	266.7	24.5	5.5	228.6	13.5	22	47.625	117.602	12.700	53.111	197.0
320	340	317.5	26.5	5.5	279.4	17.0	32.5	53.975	133.35	12.700	59.563	264.5
K...149												
140	168	114.3	15	5.0	149.2	11.0	16	22.225	57.150	4.763	24.346	76.0
180	226	215.9	22	5.5	184.1	13.5	26	28.575	69.850	6.350	31.394	150.0
210	226	215.9	22	5.5	184.1	13.5	12	34.925	85.850	7.938	38.443	164.0
250	226	215.9	22	5.5	184.1	13.5	12	41.275	101.600	9.525	45.491	164.0
280	285	266.7	24.5	5.5	228.6	13.5	22	47.625	117.602	12.700	53.111	177.0
320	340	317.5	26.5	5.5	279.4	17.0	32.5	53.975	133.350	12.700	59.563	259.5
360	340	317.5	26.5	5.5	279.4	17.0	34.5	60.325	149.352	15.875	67.208	278.0
K...169												
180	226	215.9	22	5.5	184.1	13.5	26	28.575	69.850	6.350	31.394	148.5
210	226	215.9	22	5.5	184.1	13.5	12	34.925	85.850	7.938	38.443	157.5
250	226	215.9	22	5.5	184.1	13.5	12	41.275	101.600	9.525	45.491	157.5
280	285	266.7	24.5	5.5	228.6	13.5	22	47.625	117.602	12.700	53.111	170.5
320	340	317.5	26.5	5.5	279.4	17.0	32.5	53.975	133.35	12.700	59.563	247.0
360	340	317.5	26.5	5.5	279.4	17.0	34.5	60.325	149.352	15.875	67.208	241.5
K...189												
210	226	215.9	22	5.5	184.1	13.5	12	34.925	85.850	7.938	38.443	144.5
250	226	215.9	22	5.5	184.1	13.5	12	41.275	101.600	9.525	45.491	144.5
280	285	266.7	24.5	5.5	228.6	13.5	22	47.625	117.602	12.700	53.111	157.5
320	340	317.5	26.5	5.5	279.4	17.0	32.5	53.975	133.35	12.700	59.563	232.5
360	340	317.5	26.5	5.5	279.4	17.0	34.5	60.325	149.352	15.875	67.208	253.0

SIMOGEAR Gearboxes

Bevel gearbox with adapter K3

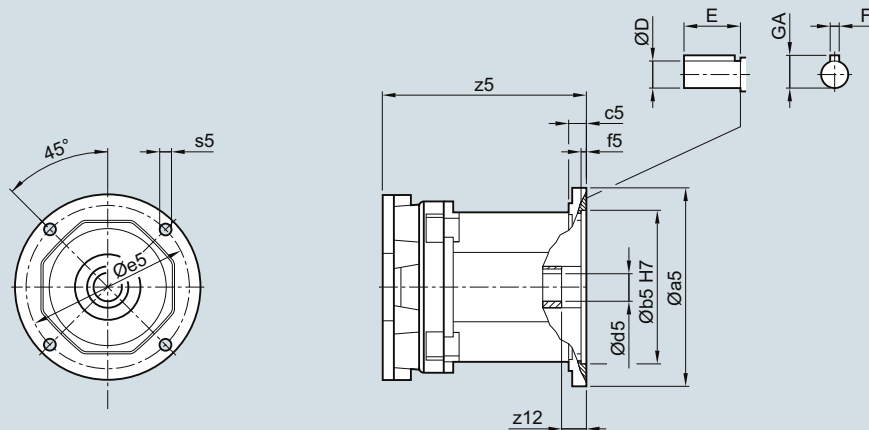
Dimensions**B...29 to B...49 and K...39 to K...79 gearboxes****B..030K3, B.F.030K3, B.Z.030K3, BAD.030K3
K..030K3, K.F.030K3, K.Z.030K3, KAD.030K3**

Adapter	a5	b5	c5	f5	e5	s5	z12	d5/D	E	F	GA	z5
B...29												
56	168	114.3	15	5.0	149.2	11.0	27.5	15.875	47.752	4.763	17.895	201.0
140	168	114.3	15	5.0	149.2	11.0	28.0	22.225	57.150	4.763	24.346	201.0
180	226	215.9	22	5.5	184.1	13.5	42.0	28.575	69.850	6.350	31.394	257.0
B...39												
56	168	114.3	15	5.0	149.2	11.0	27.5	15.875	47.752	4.763	17.895	201.0
140	168	114.3	15	5.0	149.2	11.0	28.0	22.225	57.150	4.763	24.346	201.0
180	226	215.9	22	5.5	184.1	13.5	42.0	28.575	69.850	6.350	31.394	257.0
B...49												
56	168	114.3	15	5.0	149.2	11.0	27.5	15.875	47.752	4.763	17.895	191.5
140	168	114.3	15	5.0	149.2	11.0	28.0	22.225	57.150	4.763	24.346	191.5
180	226	215.9	22	5.5	184.1	13.5	42.0	28.575	69.850	6.350	31.394	247.5
210	226	215.9	22	5.5	184.1	13.5	49.5	34.925	85.850	7.938	38.443	318.0
K...39												
56	168	114.3	15	5.0	149.2	11.0	27.5	15.875	47.752	4.763	17.895	201.0
140	168	114.3	15	5.0	149.2	11.0	28.0	22.225	57.150	4.763	24.346	201.0
180	226	215.9	22	5.5	184.1	13.5	42.0	28.575	69.850	6.350	31.394	257.0
K...49												
56	168	114.3	15	5.0	149.2	11.0	27.5	15.875	47.752	4.763	17.895	191.5
140	168	114.3	15	5.0	149.2	11.0	28.0	22.225	57.150	4.763	24.346	191.5
180	226	215.9	22	5.5	184.1	13.5	42.0	28.575	69.850	6.350	31.394	247.5
210	226	215.9	22	5.5	184.1	13.5	49.5	34.925	85.850	7.938	38.443	318.0
K...69												
56	168	114.3	15	5.0	149.2	11.0	27.5	15.875	47.752	4.763	17.895	191.5
140	168	114.3	15	5.0	149.2	11.0	28.0	22.225	57.150	4.763	24.346	191.5
180	226	215.9	22	5.5	184.1	13.5	42.0	28.575	69.850	6.350	31.394	247.5
210	226	215.9	22	5.5	184.1	13.5	49.5	34.925	85.850	7.938	38.443	318.0
K...79												
56	168	114.3	15	5.0	149.2	11.0	27.5	15.875	47.752	4.763	17.895	191.5
140	168	114.3	15	5.0	149.2	11.0	28.0	22.225	57.150	4.763	24.346	191.5
180	226	215.9	22	5.5	184.1	13.5	42.0	28.575	69.850	6.350	31.394	247.5
210	226	215.9	22	5.5	184.1	13.5	49.5	34.925	85.850	7.938	38.443	318.0

K...89 to K...189 gearboxes

K...030K3, K.F.030K3, K.Z.030K3, KAD.030K3

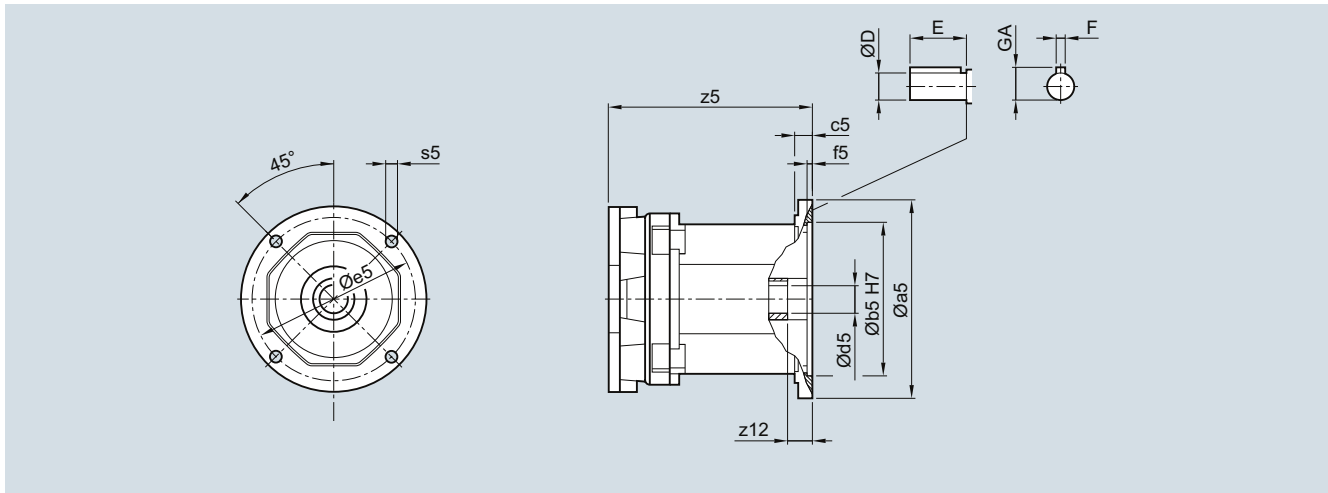

Adapter	a5	b5	c5	f5	e5	s5	z12	d5/D	E	F	GA	z5
K...89												
56	168	114.3	15	5.0	149.2	11.0	27.5	15.875	47.752	4.763	17.895	185.5
140	168	114.3	15	5.0	149.2	11.0	28.0	22.225	57.150	4.763	24.346	185.5
180	226	215.9	22	5.5	184.1	13.5	42.0	28.575	69.850	6.350	31.394	241.5
210	226	215.9	22	5.5	184.1	13.5	49.5	34.925	85.850	7.938	38.443	312.0
250	236	215.9	22	5.5	184.1	13.5	55.5	41.275	101.600	9.525	45.491	342.0
K...109												
140	168	114.3	15	5.0	149.2	11.0	28.0	22.225	57.150	4.763	24.346	172.5
180	226	215.9	22	5.5	184.1	13.5	42.0	28.575	69.850	6.350	31.394	224.5
210	226	215.9	22	5.5	184.1	13.5	49.5	34.925	85.850	7.938	38.443	295.0
250	236	215.9	22	5.5	184.1	13.5	55.5	41.275	101.600	9.525	45.491	325.0
280	285	266.7	24.5	5.5	228.6	13.5	66.5	47.625	117.602	12.7	53.111	343.0
K...129												
140	168	114.3	15	5.0	149.2	11.0	28.0	22.225	57.150	4.763	24.346	165.5
180	226	215.9	22	5.5	184.1	13.5	42.0	28.575	69.850	6.350	31.394	215.5
210	226	215.9	22	5.5	184.1	13.5	49.5	34.925	85.850	7.938	38.443	286.0
250	236	215.9	22	5.5	184.1	13.5	55.5	41.275	101.600	9.525	45.491	316.0
280	285	266.7	24.5	5.5	228.6	13.5	66.5	47.625	117.602	12.7	53.111	334.0
320	340	317.5	26.5	5.5	279.4	17	76.5	53.975	133.35	12.7	59.563	411.5
K...149												
140	168	114.3	15	5.0	149.2	11.0	28.0	22.225	57.150	4.763	24.346	158.5
180	226	215.9	22	5.5	184.1	13.5	42.0	28.575	69.850	6.350	31.394	206.5
210	226	215.9	22	5.5	184.1	13.5	49.5	34.925	85.850	7.938	38.443	275.0
250	236	215.9	22	5.5	184.1	13.5	55.5	41.275	101.600	9.525	45.491	305.0
280	285	266.7	24.5	5.5	228.6	13.5	66.5	47.625	117.602	12.7	53.111	323.0
320	340	317.5	26.5	5.5	279.4	17	76.5	53.975	133.35	12.7	59.563	406.5
360	340	317.5	26.5	5.5	279.4	17	83.5	60.325	149.352	15.875	67.21	454.0
K...169												
180	226	215.9	22	5.5	184.1	13.5	42.0	28.575	69.850	6.350	31.394	205.0
210	226	215.9	22	5.5	184.1	13.5	49.5	34.925	85.850	7.938	38.443	268.5
250	236	215.9	22	5.5	184.1	13.5	55.5	41.275	101.600	9.525	45.491	298.5
280	285	266.7	24.5	5.5	228.6	13.5	66.5	47.625	117.602	12.7	53.111	316.5
320	340	317.5	26.5	5.5	279.4	17	76.5	53.975	133.35	12.7	59.563	394.0
360	340	317.5	26.5	5.5	279.4	17	83.5	60.325	149.352	15.875	67.21	447.5
K...189												
210	226	215.9	22	5.5	184.1	13.5	49.5	34.925	85.850	7.938	38.443	255.5
250	236	215.9	22	5.5	184.1	13.5	55.5	41.275	101.600	9.525	45.491	285.5
280	285	266.7	24.5	5.5	228.6	13.5	66.5	47.625	117.602	12.7	53.111	303.5
320	340	317.5	26.5	5.5	279.4	17	76.5	53.975	133.35	12.7	59.563	379.5
360	340	317.5	26.5	5.5	279.4	17	83.5	60.325	149.352	15.875	67.21	429.5

SIMOGEAR Gearboxes

Bevel gearboxes

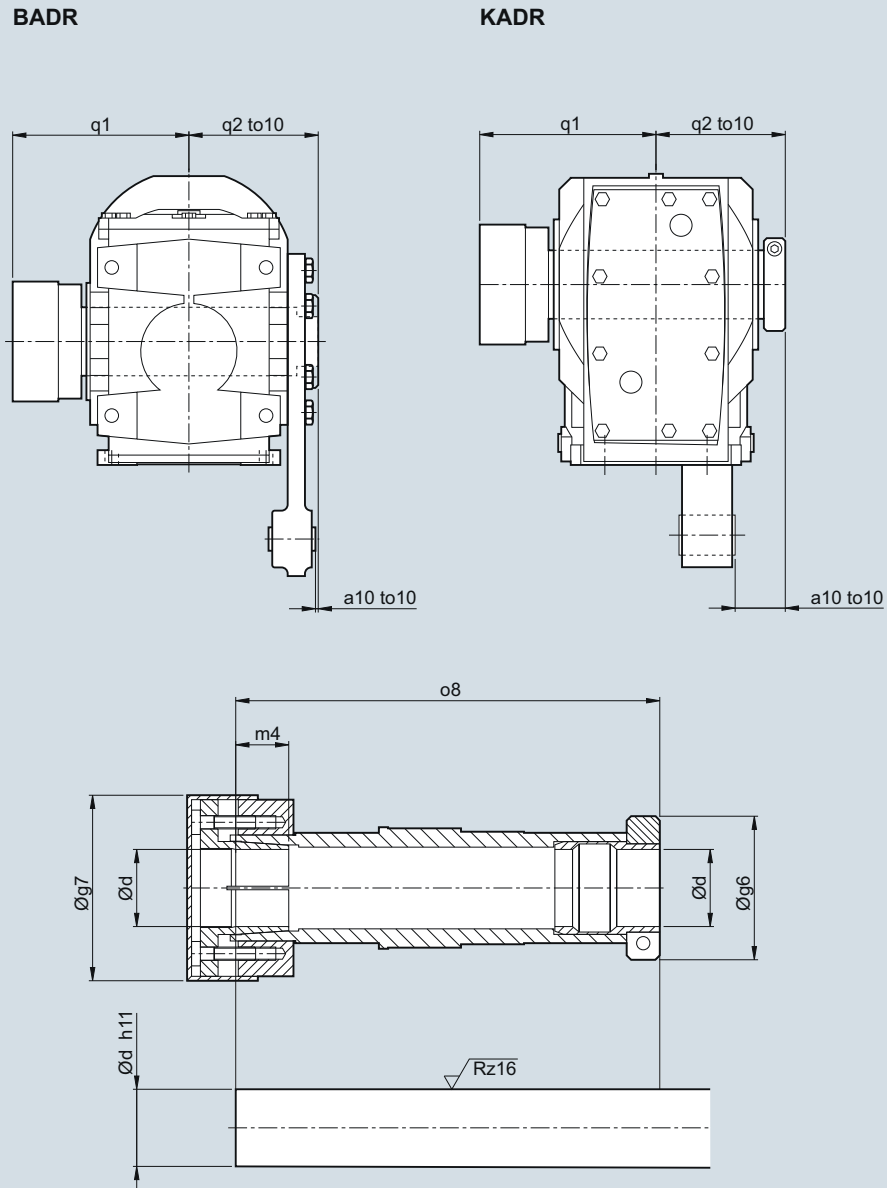
Dimensions**SIMOLOC assembly system**

Note mounting tolerance to10 when positioning the torque arm.

SIMOLOC assembly system (continued)

d	g6	g7	m4	o8	q1	q2	a10	to10
BADR29								
20	58.5	56	18.5	151	102	75	11	+2.1
1"								+0.6
0.75"								
BADR39								
30	62.0	76	22	180.5	116	85	2.5	+2.2
25								+0.7
1.25"								
1.1875"								
1"								
BADR49								
35	65.0	84	24	210.0	134	100	-2.5	+2.6
30								+0.8
1.375"								
1.4375"								
1.25"								
1.1875"								
40	79.5	94	30	220	140	104	1.5	
1.625"								
KADR39								
30	62.0	76	22	160.5	106	75	39	+2.2
25								+0.7
1.25"								
1.1875"								
1"								
KADR49								
35	65.0	84	24	192.0	124	90	35	+2.6
30								+0.8
1.375"								
1.4375"								
1.25"								
1.1875"								
KADR69								
40	79.5	94	30	217.5	138	102	39	+2.5
35								+0.7
1.5"								
1.625"								
1.4375"								
1.375"								
KADR79								
40	79.5	94	30	232.0	150	109	46	+3.2
35								+1.4
1.5"								
1.625"								
1.4375"								
1.375"								
KADR89								
50	89.0	114	32	264.0	171	124	45	+3.4
40								+1.5
2"								
1.9375"								
1.75"								
1.625"								

SIMOGEAR Gearboxes

Bevel gearboxes

Dimensions

Protection cover for hollow shaft

Protection cover for hollow shaft and hollow shaft with shrink disk

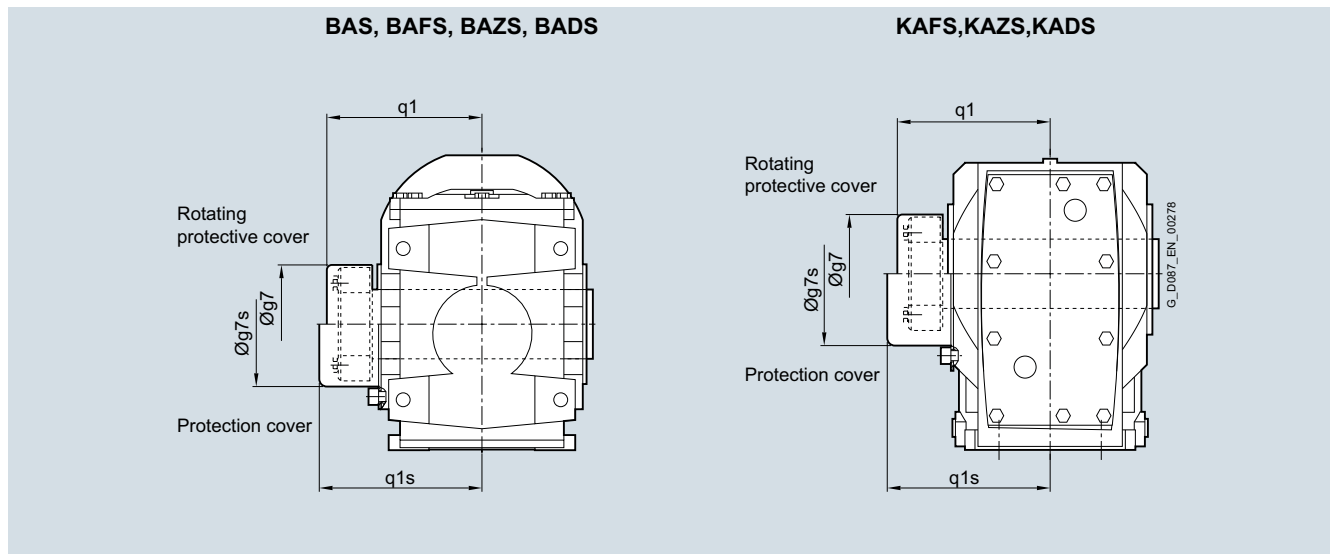

Gearbox type	BA..29	BA..39	BA..49	KA..39	KA..49	KA..69	KA..79	KA..89	KA..109	KA..129	KA..149	KA..169	KA..189
Rotating protective cover with shrink disk version													
g7	55	84	84	76.0	84	84	94.0	119.0	142.0	159.0	201.0	234.0	267.0
q1	85	102	117	89.5	107	115	125.5	142.5	162.5	198.5	233.5	291.0	343.5
Protection cover													
g7s	58	86	86	82.5	86	99	99.0	137.0	186.8	186.8	217.0	257.5	309.5
q1s	91	119	134	109.0	122	126	132.5	176.5	195.0	225.0	243.0	313.0	371.5

Protection cover for hollow shaft with SIMOLOC assembly system

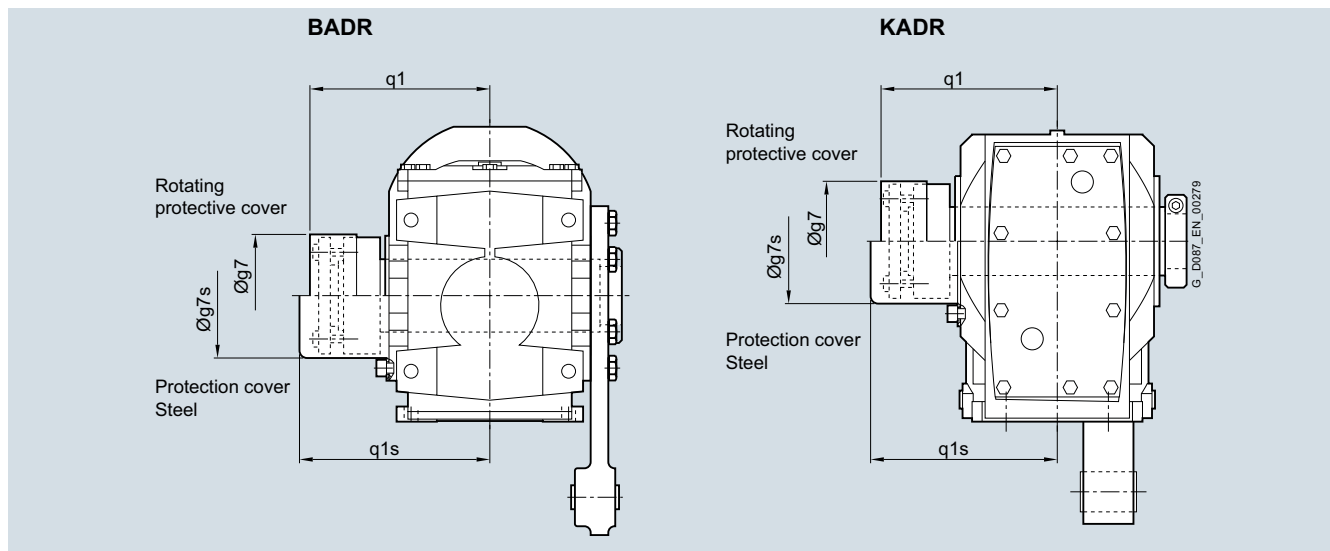

Gearbox type	BADR29	BADR39	BADR49	KADR39	KADR49	KADR69	KADR79	KADR89
Rotating protective cover								
g7	56	76	84 (94)	76	84	94	94	114
q1	102	116	134 (140)	106	124	138	150	171
Protection cover								
g7s	58	82.5	86 (99)	82.5	86	99	99	137
q1s	105	119.0	137 (143)	109	127	141	153	174

() Dimension in brackets for hollow shaft d=40 and d=1.625"

Inner contour of the flange design

Notes regarding the design of the customer's interface.

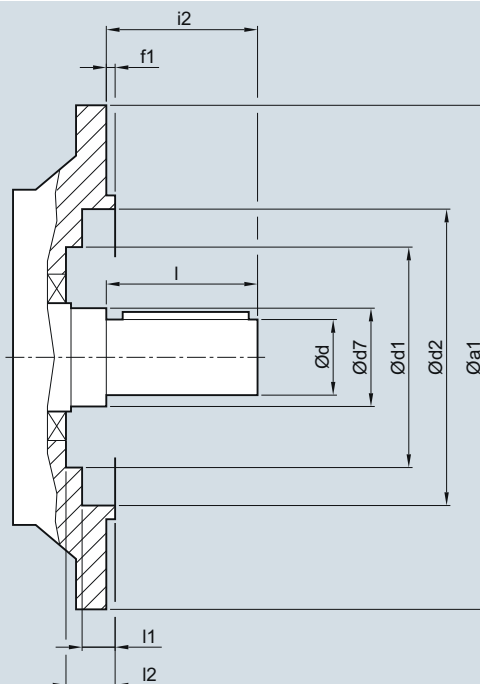
BF, KF

Gearbox type	a1	d	d7	d1	d2	f1	i2	l	l1	l2
BF19	120	20	30	60	68	3.0	40	40	23.5	29.5
BF29	120	20	40	-	70	3.0	40	40	24.0	-
	160	20	40	70	101	3.5	40	40	8.5	24.5
BF39	160	30	55	93	100	3.5	60	60	11.0	31.5
	200	30	55	93	119	3.5	60	60	16.0	31.5
BF49	200	35	55	93	119	3.5	70	70	16.0	31.5
KF39	160	25	30	-	100	3.5	50	50	5.0	-
KF49	200	30	35	-	118	3.5	60	60	5.5	-
KF69	250	35	45	-	165	4.0	70	70	6.5	-
KF79	250	40	55	-	165	4.0	80	80	6.5	-
KF89	300	50	55	-	165	4.0	100	100	8.0	-
KF109	350	60	65	-	235	5.0	120	120	9.0	-
KF129	450	70	75	-	336	5.0	140	140	9.0	-
KF149	450	90	100	-	336	5.0	170	170	10.0	-
KF169	550	110	120	-	427	5.0	210	210	10.0	-
KF189	660	120	160	-	517	6.0	210	210	11.0	-

SIMOGEAR Gearboxes

Bevel gearboxes

Dimensions**Inner contour of the flange design (continued)**

Notes regarding the design of the customer's interface, e.g. plug-in shaft for hollow shaft design

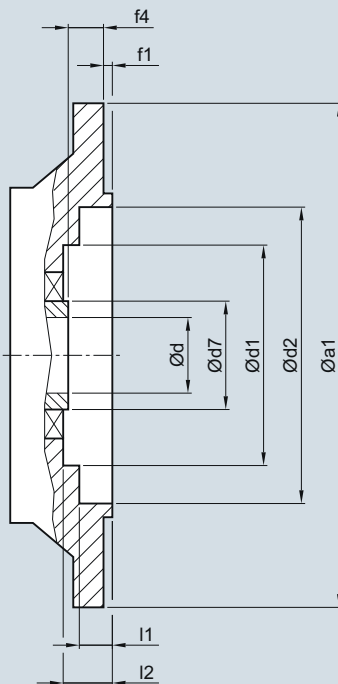
BAF., KAF.

Gearbox type	a1	d	d7	d1	d2	f1	f4	l1	l2
BAF.19	120	20	30	60	68	3.0	30.0	23.5	29.5
BAF.29	120	20/	40	-	70	3.0	20.0	24.0	-
		25							
BAF.39	160	20/	40	70	101	3.5	20.0	8.5	24.5
		25							
BAF.39	160	30	55	93	100	3.5	27.0	11.0	31.5
		35							
		40							
BAF.39	200	30	55	93	119	3.5	27.0	16.0	31.5
		35							
		40							
BAF.49	200	35	55	93	119	3.5	27.0	16.0	31.5
		40							
KAF.39	160	30	45	80	102	3.5	24.0	2.0	29.5
KAF.49	200	35	50	90	120	3.5	25.0	4.0	30.5
KAF.69	250	40	55	104	165	4.0	23.5	2.0	29.5
KAF.79	250	40	55	104	165	4.0	23.0	2.0	29.5
KAF.89	300	50	70	135	215	4.0	37.0	2.0	44.5
KAF.109	350	60	85	184	210	5.0	36.0	13.0	45.0
KAF.129	450	70	95	184	336	5.0	41.5	16.5	48.5
KAF.149	450	90	120	214	219	5.0	41.0	40.0	50.0
KAF.169	550	100	140	254	426	5.0	56.0	14.5	56.0
KAF.189	660	120	160	306	518	6.0	66.0	6.0	62.0

Pin holes

In the case of gearboxes K.Z.109 and K.Z.129, the customer's interface can be pinned on the housing flange (C type).

The output flanges have been designed to ensure the reliable transmission of the permissible torques and radial forces by the bolt connections.

If additional fastening is required, in the case of high shock loads, for example, the existing drilled pin holes can be used.

The gearboxes can also be drilled and pinned together with the machine. The listed dimensions must be complied with.

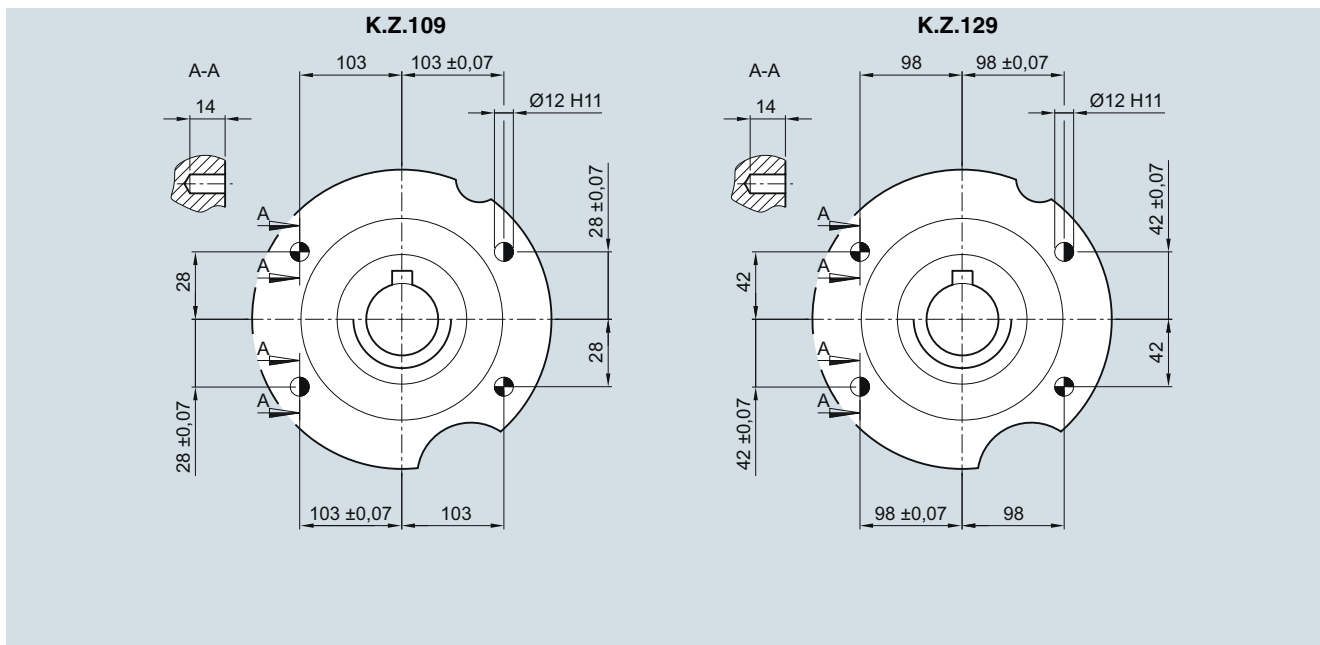

- ① Spring pins, heavy-duty design, to DIN 1481: Use pin holes provided in the housing flange.
- ② Grooved cylindrical pins with chamfer to EN 28740/ISO 8740: Drill connecting component together with housing.

SIMOGEAR Gearboxes

Notes

Helical worm gearboxes

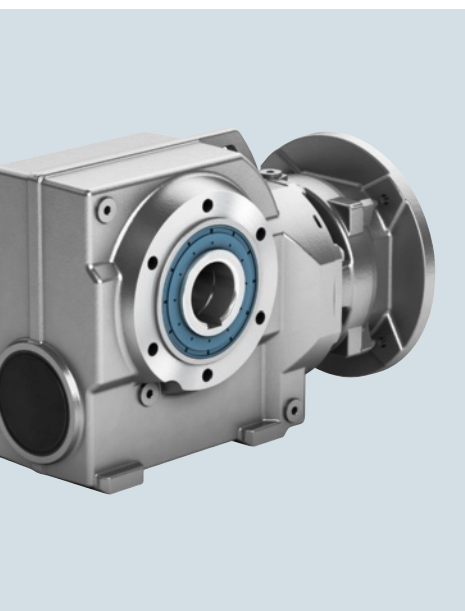

6/2	Orientation	6/42	Dimensions (continued)
6/3	Transmission ratios and torques		Helical worm gearbox with adapter KQ
6/3	Selection and ordering data	6/42	C..29
6/8	Efficiencies	6/43	C.F.29
6/8	Selection and ordering data	6/44	C.Z.29
6/18	Dimensions	6/45	CAD.29
6/18	Dimensional drawing overview	6/46	C..39
	Helical worm gearbox with adapter K4	6/47	C.F.39
6/21	C..29	6/48	C.Z.39
6/22	C.F.29	6/49	CAD.39
6/23	C.Z.29	6/50	C..49
6/24	CAD.29	6/51	C.F.49
6/25	C..39	6/52	C.Z.49
6/26	C.F.39	6/53	CAD.49
6/27	C.Z.39	6/54	C..69
6/28	CAD.39	6/55	C.F.69
6/29	C..49	6/56	C.Z.69
6/30	C.F.49	6/57	CAD.69
6/31	C.Z.49	6/58	C..89
6/32	CAD.49	6/59	C.F.89
6/33	C..69	6/60	C.Z.89
6/34	C.F.69	6/61	CAD.89
6/35	C.Z.69		Helical worm gearbox with adapter KQS
6/36	CAD.69	6/62	C..29 to C..89
6/37	C..89		Helical worm gearbox with adapter K8
6/38	C.F.89	6/63	C..49 to C..89
6/39	C.Z.89		Helical worm gearbox with adapter K5
6/40	CAD.89	6/64	C..29 to C..89
	Helical worm gearbox with adapter K2		Helical worm gearbox with adapter K3
6/41	C..29 to C..89	6/65	C..29 to C..89
		6/66	SIMOLOC assembly system
		6/68	Protection cover for hollow shaft
		6/69	Inner contour of the flange design

SIMOGEAR Gearboxes

Helical worm gearboxes

Orientation

SIMOGEAR helical worm gearbox C

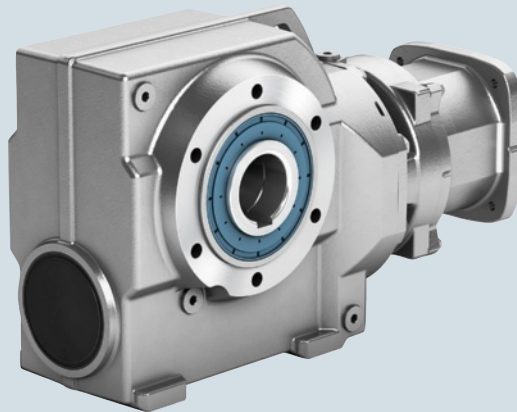

Fig. 6/1 Helical worm gearbox C

Gearbox designation	Number of sizes	Maximum output torque	Transmission ratio	Maximum motor power
		T_{2N} Nm	i -	P_1 kW
C29 ... C89 (2-stage)	5	95 ... 1 410	6.2 ... 363	9.2

6

SIMOGEAR helical worm gearboxes are available in the following versions for mounting in any position:

- 2 stages
- Shaft-mounted design with torque arm
- Flange-mounted design
- Design with integrated housing flange
- Foot-mounted design
- Hollow-shaft design with feather key or shrink disk
- Solid shaft design with feather key (at one end or both ends)

For helical worm gearboxes, the torque arm is supplied loose to enable it to be mounted as required on site. The position of the torque arm can be freely selected.

SIMOGEAR Gearboxes

Helical worm gearboxes

Transmission ratios and torques

Selection and ordering data

Gearbox						Adapter							Article No.	
<i>i</i>	<i>n</i> ₂ rpm	<i>T</i> _{2N} Nm	<i>F</i> _{R2} N	<i>J</i> _G 10 ⁻⁴ kgm ²	<i>R</i> _{ex}	K4	63	71	80	90	100	112	132	(Article No. supplement → below)
-						K2			80	90	100	112	132	
						KQ		703	704	706		708	710	
						K8						808	810	
						K5		56		140	180		210	
						K3		56		140	180		210	
C.29														
265.20	5.5	108	4 140	0.05	1326/5	✓	✓	✓						2KJ3601 - ■ ■ A 0 ■ - 0 ■ M2
230.10	6.3	108	4 140	0.05	2301/10	✓	✓	✓						2KJ3601 - ■ ■ A 0 ■ - 0 ■ L2
209.18	6.9	109	4 130	0.07	2301/11	✓	✓	✓	✓					2KJ3601 - ■ ■ A 0 ■ - 0 ■ K2
179.40	8.1	110	4 130	0.08	897/5	✓	✓	✓	✓					2KJ3601 - ■ ■ A 0 ■ - 0 ■ J2
163.09	8.9	110	4 130	0.10	1794/11	✓	✓	✓	✓					2KJ3601 - ■ ■ A 0 ■ - 0 ■ H2
143.00	10	110	4 130	0.11	143/1	✓	✓	✓	✓					2KJ3601 - ■ ■ A 0 ■ - 0 ■ G2
127.64	11	110	4 130	0.14	1404/11	✓	✓	✓	✓					2KJ3601 - ■ ■ A 0 ■ - 0 ■ F2
113.75	13	110	4 130	0.16	455/4	✓	✓	✓	✓					2KJ3601 - ■ ■ A 0 ■ - 0 ■ E2
105.00	14	110	4 130	0.20	105/1	✓	✓	✓	✓					2KJ3601 - ■ ■ A 0 ■ - 0 ■ D2
91.93	16	110	4 130	0.22	1287/14	✓	✓	✓	✓					2KJ3601 - ■ ■ A 0 ■ - 0 ■ C2
80.60	18	110	4 130	0.22	403/5	✓	✓	✓	✓					2KJ3601 - ■ ■ A 0 ■ - 0 ■ B2
73.12	20	110	4 130	0.28	585/8	✓	✓	✓	✓					2KJ3601 - ■ ■ A 0 ■ - 0 ■ A2
68.82	21	110	4 130	0.33	1170/17	✓	✓	✓	✓					2KJ3601 - ■ ■ A 0 ■ - 0 ■ X1
60.67	24	110	4 130	0.36	182/3	✓	✓	✓	✓					2KJ3601 - ■ ■ A 0 ■ - 0 ■ W1
52.65	28	110	4 130	0.48	1053/20	✓	✓	✓	✓					2KJ3601 - ■ ■ A 0 ■ - 0 ■ V1
49.87	29	102	4 170	0.05	748/15	✓	✓	✓	✓					2KJ3601 - ■ ■ A 0 ■ - 0 ■ U1
43.27	34	103	4 160	0.06	649/15	✓	✓	✓	✓					2KJ3601 - ■ ■ A 0 ■ - 0 ■ T1
39.33	37	103	4 160	0.07	118/3	✓	✓	✓	✓					2KJ3601 - ■ ■ A 0 ■ - 0 ■ S1
33.73	43	104	4 160	0.09	506/15	✓	✓	✓	✓					2KJ3601 - ■ ■ A 0 ■ - 0 ■ R1
32.64	44	90	4 230	0.05	816/25	✓	✓	✓	✓					2KJ3601 - ■ ■ A 0 ■ - 0 ■ Q1
28.32	51	90	4 230	0.06	708/25	✓	✓	✓	✓					2KJ3601 - ■ ■ A 0 ■ - 0 ■ P1
25.75	56	91	4 220	0.07	1416/55	✓	✓	✓	✓					2KJ3601 - ■ ■ A 0 ■ - 0 ■ N1
22.08	66	91	4 220	0.09	552/25	✓	✓	✓	✓					2KJ3601 - ■ ■ A 0 ■ - 0 ■ M1
20.07	72	92	4 220	0.11	1104/55	✓	✓	✓	✓					2KJ3601 - ■ ■ A 0 ■ - 0 ■ L1
17.60	82	92	3 980	0.13	88/5	✓	✓	✓	✓					2KJ3601 - ■ ■ A 0 ■ - 0 ■ K1
15.71	92	92	3 780	0.15	864/55	✓	✓	✓	✓					2KJ3601 - ■ ■ A 0 ■ - 0 ■ J1
14.00	104	93	3 570	0.18	14/1	✓	✓	✓	✓					2KJ3601 - ■ ■ A 0 ■ - 0 ■ H1
12.92	112	93	3 440	0.22	168/13	✓	✓	✓	✓					2KJ3601 - ■ ■ A 0 ■ - 0 ■ G1
11.31	128	94	3 220	0.25	396/35	✓	✓	✓	✓					2KJ3601 - ■ ■ A 0 ■ - 0 ■ F1
9.92	146	94	3 020	0.26	248/25	✓	✓	✓	✓					2KJ3601 - ■ ■ A 0 ■ - 0 ■ E1
9.00	161	91	2 960	0.33	9/1	✓	✓	✓	✓					2KJ3601 - ■ ■ A 0 ■ - 0 ■ D1
8.47	171	90	2 950	0.38	144/17	✓	✓	✓	✓					2KJ3601 - ■ ■ A 0 ■ - 0 ■ C1
7.47	194	86	2 920	0.43	112/15	✓	✓	✓	✓					2KJ3601 - ■ ■ A 0 ■ - 0 ■ B1
6.48	224	82	2 880	0.57	162/25	✓	✓	✓	✓					2KJ3601 - ■ ■ A 0 ■ - 0 ■ A1

Article No. supplement

Shaft design → Page 9/39

Adapter size

1 or 9

K4	B	C	D	E	F	G	H		4
K2			D	E	F	G	H		2
KQ		A	B	C		D	E		7
K8						A	B		8
K5		A		B	C		D		5
K3		A		B	C		D		3

Adapter type

Gearbox mounting type → Page 9/35

A, D, F or H

SIMOGEAR Gearboxes

Helical worm gearboxes

Transmission ratios and torques

Selection and ordering data (continued)

Gearbox						Adapter							Article No.	
<i>i</i>	n_2 rpm	T_{2N} Nm	F_{R2} N	J_G 10^{-4} kgm ²	R_{ex}	K4	63	71	80	90	100	112	132	(Article No. supplement → below)
-						K2			80	90	100	112	132	
						KQ		703	704	706		708	710	
						K8						808	810	
						K5		56		140	180		210	
						K3		56		140	180		210	
C.39														
299.00	4.8	192	6 180	0.04	299/1	✓	✓							2KJ3602 - ■ ■ A 0 ■ - 0 ■ N2
265.20	5.5	192	6 180	0.05	1326/5	✓	✓	✓						2KJ3602 - ■ ■ A 0 ■ - 0 ■ M2
230.10	6.3	193	6 180	0.06	2301/10	✓	✓	✓						2KJ3602 - ■ ■ A 0 ■ - 0 ■ L2
209.18	6.9	193	6 180	0.07	2301/11	✓	✓	✓	✓					2KJ3602 - ■ ■ A 0 ■ - 0 ■ K2
179.40	8.1	193	6 180	0.09	897/5	✓	✓	✓	✓					2KJ3602 - ■ ■ A 0 ■ - 0 ■ J2
163.09	8.9	193	6 180	0.11	1794/11	✓	✓	✓	✓					2KJ3602 - ■ ■ A 0 ■ - 0 ■ H2
143.00	10	194	6 170	0.13	143/1	✓	✓	✓	✓	✓				2KJ3602 - ■ ■ A 0 ■ - 0 ■ G2
127.64	11	194	6 170	0.16	1404/11	✓	✓	✓	✓	✓				2KJ3602 - ■ ■ A 0 ■ - 0 ■ F2
113.75	13	194	6 170	0.19	455/4	✓	✓	✓	✓	✓				2KJ3602 - ■ ■ A 0 ■ - 0 ■ E2
105.00	14	194	6 170	0.23	105/1	✓	✓	✓	✓	✓				2KJ3602 - ■ ■ A 0 ■ - 0 ■ D2
91.93	16	194	6 170	0.27	1287/14	✓	✓	✓	✓	✓				2KJ3602 - ■ ■ A 0 ■ - 0 ■ C2
80.60	18	194	6 170	0.26	403/5	✓	✓	✓	✓	✓				2KJ3602 - ■ ■ A 0 ■ - 0 ■ B2
73.12	20	194	6 170	0.36	585/8	✓	✓	✓	✓	✓				2KJ3602 - ■ ■ A 0 ■ - 0 ■ A2
68.82	21	194	6 170	0.43	1170/17	✓	✓	✓	✓	✓				2KJ3602 - ■ ■ A 0 ■ - 0 ■ X1
60.67	24	183	6 210	0.47	182/3	✓	✓	✓	✓	✓				2KJ3602 - ■ ■ A 0 ■ - 0 ■ W1
52.65	28	170	6 260	0.64	1053/20	✓	✓	✓	✓	✓				2KJ3602 - ■ ■ A 0 ■ - 0 ■ V1
49.87	29	198	6 160	0.06	748/15	✓	✓	✓	✓					2KJ3602 - ■ ■ A 0 ■ - 0 ■ U1
43.27	34	199	6 150	0.07	649/15	✓	✓	✓	✓					2KJ3602 - ■ ■ A 0 ■ - 0 ■ T1
39.33	37	200	6 150	0.08	118/3	✓	✓	✓	✓					2KJ3602 - ■ ■ A 0 ■ - 0 ■ S1
33.73	43	200	5 750	0.11	506/15	✓	✓	✓	✓					2KJ3602 - ■ ■ A 0 ■ - 0 ■ R1
32.64	44	215	5 280	0.07	816/25	✓	✓	✓	✓					2KJ3602 - ■ ■ A 0 ■ - 0 ■ Q1
28.32	51	235	4 700	0.08	708/25	✓	✓	✓	✓					2KJ3602 - ■ ■ A 0 ■ - 0 ■ P1
25.75	56	235	4 470	0.1	1416/55	✓	✓	✓	✓					2KJ3602 - ■ ■ A 0 ■ - 0 ■ N1
22.08	66	235	4 110	0.13	552/25	✓	✓	✓	✓					2KJ3602 - ■ ■ A 0 ■ - 0 ■ M1
20.07	72	235	3 900	0.16	1104/55	✓	✓	✓	✓					2KJ3602 - ■ ■ A 0 ■ - 0 ■ L1
17.60	82	225	3 730	0.19	88/5	✓	✓	✓	✓	✓				2KJ3602 - ■ ■ A 0 ■ - 0 ■ K1
15.71	92	215	3 610	0.23	864/55	✓	✓	✓	✓	✓				2KJ3602 - ■ ■ A 0 ■ - 0 ■ J1
14.00	104	205	3 500	0.28	14/1	✓	✓	✓	✓	✓				2KJ3602 - ■ ■ A 0 ■ - 0 ■ H1
12.92	112	199	3 410	0.34	168/13	✓	✓	✓	✓	✓				2KJ3602 - ■ ■ A 0 ■ - 0 ■ G1
11.31	128	189	3 280	0.41	396/35	✓	✓	✓	✓	✓				2KJ3602 - ■ ■ A 0 ■ - 0 ■ F1
9.92	146	181	3 140	0.44	248/25	✓	✓	✓	✓	✓				2KJ3602 - ■ ■ A 0 ■ - 0 ■ E1
9.00	161	174	3 050	0.59	9/1	✓	✓	✓	✓	✓				2KJ3602 - ■ ■ A 0 ■ - 0 ■ D1
8.47	171	170	3 030	0.68	144/17	✓	✓	✓	✓	✓				2KJ3602 - ■ ■ A 0 ■ - 0 ■ C1
7.47	194	163	3 050	0.81	112/15	✓	✓	✓	✓	✓				2KJ3602 - ■ ■ A 0 ■ - 0 ■ B1
6.48	224	154	3 050	1.08	162/25	✓	✓	✓	✓	✓				2KJ3602 - ■ ■ A 0 ■ - 0 ■ A1

Article No. supplement

Shaft design → Page 9/39

Adapter size

1 or 9

K4	B	C	D	E	F	G	H	4
K2			D	E	F	G	H	2
KQ	A	B	C		D	E		7
K8					A	B		8
K5	A		B	C		D		5
K3	A		B	C		D		3

Adapter type

Gearbox mounting type → Page 9/35

A, D, F or H

SIMOGEAR Gearboxes

Helical worm gearboxes

Transmission ratios and torques

Selection and ordering data (continued)

Gearbox						Adapter							Article No.	
<i>i</i>	<i>n</i> ₂ rpm	<i>T</i> _{2N} Nm	<i>F</i> _{R2} N	<i>J</i> _G 10 ⁻⁴ kgm ²	<i>R</i> _{ex}	K4	63	71	80	90	100	112	132	(Article No. supplement → below)
-						K2			80	90	100	112	132	
						KQ		703	704	706		708	710	
						K8						808	810	
						K5		56		140	180		210	
						K3		56		140	180		210	
C.49														
299.00	4.8	350	8 410	0.04	299/1	✓	✓							2KJ3603 - ■ ■ A 0 ■ - 0 ■ N2
265.20	5.5	350	8 410	0.05	1326/5	✓	✓	✓						2KJ3603 - ■ ■ A 0 ■ - 0 ■ M2
230.10	6.3	355	8 400	0.07	2301/10	✓	✓	✓						2KJ3603 - ■ ■ A 0 ■ - 0 ■ L2
209.18	6.9	355	8 400	0.08	2301/11	✓	✓	✓	✓					2KJ3603 - ■ ■ A 0 ■ - 0 ■ K2
179.40	8.1	355	8 280	0.10	897/5	✓	✓	✓	✓					2KJ3603 - ■ ■ A 0 ■ - 0 ■ J2
163.09	8.9	355	7 950	0.13	1794/11	✓	✓	✓	✓					2KJ3603 - ■ ■ A 0 ■ - 0 ■ H2
143.00	10	355	7 500	0.15	143/1	✓	✓	✓	✓	✓	✓			2KJ3603 - ■ ■ A 0 ■ - 0 ■ G2
127.64	11	355	7 130	0.18	1404/11	✓	✓	✓	✓	✓	✓			2KJ3603 - ■ ■ A 0 ■ - 0 ■ F2
113.75	13	355	6 770	0.22	455/4	✓	✓	✓	✓	✓	✓			2KJ3603 - ■ ■ A 0 ■ - 0 ■ E2
105.00	14	355	6 530	0.26	105/1	✓	✓	✓	✓	✓	✓			2KJ3603 - ■ ■ A 0 ■ - 0 ■ D2
91.93	16	350	6 180	0.32	1287/14	✓	✓	✓	✓	✓	✓			2KJ3603 - ■ ■ A 0 ■ - 0 ■ C2
80.60	18	330	5 950	0.32	403/5	✓	✓	✓	✓	✓	✓			2KJ3603 - ■ ■ A 0 ■ - 0 ■ B2
73.12	20	315	5 790	0.44	585/8	✓	✓	✓	✓	✓	✓			2KJ3603 - ■ ■ A 0 ■ - 0 ■ A2
68.82	21	305	5 700	0.51	1170/17	✓	✓	✓	✓	✓	✓			2KJ3603 - ■ ■ A 0 ■ - 0 ■ X1
60.67	24	285	5 510	0.58	182/3	✓	✓	✓	✓	✓	✓			2KJ3603 - ■ ■ A 0 ■ - 0 ■ W1
52.65	28	265	5 300	0.78	1053/20	✓	✓	✓	✓	✓	✓			2KJ3603 - ■ ■ A 0 ■ - 0 ■ V1
49.87	29	320	4 270	0.08	748/15	✓	✓	✓	✓					2KJ3603 - ■ ■ A 0 ■ - 0 ■ U1
43.27	34	350	3 690	0.10	649/15	✓	✓	✓	✓					2KJ3603 - ■ ■ A 0 ■ - 0 ■ T1
39.33	37	400	3 060	0.12	118/3	✓	✓	✓	✓					2KJ3603 - ■ ■ A 0 ■ - 0 ■ S1
33.73	43	375	2 950	0.15	506/15	✓	✓	✓	✓					2KJ3603 - ■ ■ A 0 ■ - 0 ■ R1
30.67	47	385	2 680	0.19	92/3	✓	✓	✓	✓					2KJ3603 - ■ ■ A 0 ■ - 0 ■ Q1
26.89	54	360	2 630	0.23	242/9	✓	✓	✓	✓	✓	✓			2KJ3603 - ■ ■ A 0 ■ - 0 ■ P1
24.00	60	345	2 550	0.28	24/1	✓	✓	✓	✓	✓	✓			2KJ3603 - ■ ■ A 0 ■ - 0 ■ N1
21.39	68	330	2 470	0.34	385/18	✓	✓	✓	✓	✓	✓			2KJ3603 - ■ ■ A 0 ■ - 0 ■ M1
19.74	73	315	2 460	0.41	770/39	✓	✓	✓	✓	✓	✓			2KJ3603 - ■ ■ A 0 ■ - 0 ■ L1
17.29	84	300	2 360	0.51	121/7	✓	✓	✓	✓	✓	✓			2KJ3603 - ■ ■ A 0 ■ - 0 ■ K1
15.16	96	285	2 280	0.56	682/45	✓	✓	✓	✓	✓	✓			2KJ3603 - ■ ■ A 0 ■ - 0 ■ J1
13.75	105	275	2 210	0.73	55/4	✓	✓	✓	✓	✓	✓			2KJ3603 - ■ ■ A 0 ■ - 0 ■ H1
12.94	112	270	2 170	0.85	220/17	✓	✓	✓	✓	✓	✓			2KJ3603 - ■ ■ A 0 ■ - 0 ■ G1
11.41	127	255	2 110	1.02	308/27	✓	✓	✓	✓	✓	✓			2KJ3603 - ■ ■ A 0 ■ - 0 ■ F1
9.90	146	245	2 000	1.36	99/10	✓	✓	✓	✓	✓	✓			2KJ3603 - ■ ■ A 0 ■ - 0 ■ E1
9.00	161	255	1 120	1.03	9/1	✓	✓	✓	✓	✓	✓			2KJ3603 - ■ ■ A 0 ■ - 0 ■ D1
8.47	171	255	1 280	1.18	144/17	✓	✓	✓	✓	✓	✓			2KJ3603 - ■ ■ A 0 ■ - 0 ■ C1
7.47	194	240	1 570	1.45	112/15	✓	✓	✓	✓	✓	✓			2KJ3603 - ■ ■ A 0 ■ - 0 ■ B1
6.48	224	230	1 840	1.93	162/25	✓	✓	✓	✓	✓	✓			2KJ3603 - ■ ■ A 0 ■ - 0 ■ A1

Article No. supplement

Shaft design → Page 9/39

Adapter size

1 or 9

K4	B	C	D	E	F	G	H			4
K2			D	E	F	G	H			2
KQ		A	B	C		D	E			7
K8						A	B			8
K5		A		B	C		D			5
K3		A		B	C		D			3

Adapter type

Gearbox mounting type → Page 9/35

A, D, F or H

SIMOGEAR Gearboxes

Helical worm gearboxes

Transmission ratios and torques

Selection and ordering data (continued)

Gearbox						Adapter							Article No.	
<i>i</i>	<i>n</i> ₂ rpm	<i>T</i> _{2N} Nm	<i>F</i> _{R2} N	<i>J</i> _G 10 ⁻⁴ kgm ²	<i>R</i> _{ex}	K4	63	71	80	90	100	112	132	(Article No. supplement → below)
-					-	K2			80	90	100	112	132	
						KQ		703	704	706		708	710	
						K8						808	810	
						K5		56		140	180		210	
						K3		56		140	180		210	
C.69														
360.00	4.0	675	10 600	0.07	1079/3	✓	✓							2KJ3604 - ■ ■ A 0 ■ - 0 ■ M2
319.80	4.5	675	10 600	0.09	1599/5	✓	✓	✓						2KJ3604 - ■ ■ A 0 ■ - 0 ■ L2
280.80	5.2	675	10 600	0.11	1404/5	✓	✓	✓						2KJ3604 - ■ ■ A 0 ■ - 0 ■ K2
255.27	5.7	675	10 600	0.13	2808/11	✓	✓	✓	✓					2KJ3604 - ■ ■ A 0 ■ - 0 ■ J2
218.40	6.6	675	10 600	0.16	1092/5	✓	✓	✓	✓					2KJ3604 - ■ ■ A 0 ■ - 0 ■ H2
198.55	7.3	675	10 600	0.19	2184/11	✓	✓	✓	✓					2KJ3604 - ■ ■ A 0 ■ - 0 ■ G2
175.50	8.3	665	10 600	0.23	351/2	✓	✓	✓	✓	✓	✓			2KJ3604 - ■ ■ A 0 ■ - 0 ■ F2
159.55	9.1	640	10 700	0.30	1755/11	✓	✓	✓	✓	✓	✓			2KJ3604 - ■ ■ A 0 ■ - 0 ■ E2
139.75	10	590	10 600	0.35	559/4	✓	✓	✓	✓	✓	✓			2KJ3604 - ■ ■ A 0 ■ - 0 ■ D2
129.00	11	565	10 300	0.42	129/1	✓	✓	✓	✓	✓	✓			2KJ3604 - ■ ■ A 0 ■ - 0 ■ C2
114.21	13	535	10 000	0.50	1599/14	✓	✓	✓	✓	✓	✓	✓		2KJ3604 - ■ ■ A 0 ■ - 0 ■ B2
102.50	14	675	8 340	0.10	205/2	✓	✓	✓	✓					2KJ3604 - ■ ■ A 0 ■ - 0 ■ A2
90.00	16	675	7 810	0.12	90/1	✓	✓	✓	✓					2KJ3604 - ■ ■ A 0 ■ - 0 ■ X1
81.82	18	675	7 440	0.15	900/11	✓	✓	✓	✓					2KJ3604 - ■ ■ A 0 ■ - 0 ■ W1
70.00	21	660	6 940	0.18	70/1	✓	✓	✓	✓					2KJ3604 - ■ ■ A 0 ■ - 0 ■ V1
63.64	23	640	6 720	0.22	700/11	✓	✓	✓	✓					2KJ3604 - ■ ■ A 0 ■ - 0 ■ U1
56.25	26	610	6 480	0.27	225/4	✓	✓	✓	✓	✓	✓			2KJ3604 - ■ ■ A 0 ■ - 0 ■ T1
51.14	28	580	6 340	0.34	1125/22	✓	✓	✓	✓	✓	✓			2KJ3604 - ■ ■ A 0 ■ - 0 ■ S1
44.79	32	545	6 130	0.41	1075/24	✓	✓	✓	✓	✓	✓			2KJ3604 - ■ ■ A 0 ■ - 0 ■ R1
41.35	35	525	6 000	0.49	1075/26	✓	✓	✓	✓	✓	✓			2KJ3604 - ■ ■ A 0 ■ - 0 ■ Q1
36.61	40	500	5 790	0.60	1025/28	✓	✓	✓	✓	✓	✓	✓		2KJ3604 - ■ ■ A 0 ■ - 0 ■ P1
30.00	48	545	4 580	0.46	30/1	✓	✓	✓	✓	✓	✓			2KJ3604 - ■ ■ A 0 ■ - 0 ■ N1
26.28	55	515	4 420	0.56	473/18	✓	✓	✓	✓	✓	✓			2KJ3604 - ■ ■ A 0 ■ - 0 ■ M1
24.26	60	500	4 320	0.67	946/39	✓	✓	✓	✓	✓	✓			2KJ3604 - ■ ■ A 0 ■ - 0 ■ L1
21.48	68	475	4 180	0.82	451/21	✓	✓	✓	✓	✓	✓	✓		2KJ3604 - ■ ■ A 0 ■ - 0 ■ K1
17.88	81	440	3 980	1.14	143/8	✓	✓	✓	✓	✓	✓	✓		2KJ3604 - ■ ■ A 0 ■ - 0 ■ J1
15.88	91	360	3 970	0.88	1032/65	✓	✓	✓	✓	✓	✓			2KJ3604 - ■ ■ A 0 ■ - 0 ■ H1
14.06	103	355	3 740	1.09	492/35	✓	✓	✓	✓	✓	✓	✓		2KJ3604 - ■ ■ A 0 ■ - 0 ■ G1
11.70	124	360	3 320	1.54	117/10	✓	✓	✓	✓	✓	✓	✓		2KJ3604 - ■ ■ A 0 ■ - 0 ■ F1
11.01	132	360	3 200	1.76	936/85	✓	✓	✓	✓	✓	✓	✓		2KJ3604 - ■ ■ A 0 ■ - 0 ■ E1
9.87	147	360	2 870	2.10	148/15	✓	✓	✓	✓	✓	✓	✓		2KJ3604 - ■ ■ A 0 ■ - 0 ■ D1
8.40	173	360	3 110	2.90	42/5	✓	✓	✓	✓	✓	✓	✓		2KJ3604 - ■ ■ A 0 ■ - 0 ■ C1
7.20	201	360	3 170	3.80	36/5			✓	✓	✓	✓	✓		2KJ3604 - ■ ■ A 0 ■ - 0 ■ B1
6.20	234	355	3 190	5.10	31/5			✓	✓	✓	✓	✓		2KJ3604 - ■ ■ A 0 ■ - 0 ■ A1

Article No. supplement

Shaft design → Page 9/39

Adapter size

1 or 9

K4	B	C	D	E	F	G	H			4
K2			D	E	F	G	H			2
KQ		A	B	C		D	E			7
K8						A	B			8
K5		A		B	C		D			5
K3		A		B	C		D			3

Adapter type

Gearbox mounting type → Page 9/35

A, D, F or H

Selection and ordering data (continued)

Gearbox <i>i</i>	<i>n</i> ₂ rpm	<i>T</i> _{2N} Nm	<i>F</i> _{R2} N	<i>J</i> _G 10 ⁻⁴ kgm ²	<i>R</i> _{ex}	Adapter							Article No. (Article No. supplement → below)	
						K4	63	71	80	90	100	112		132
-	-	-	-	-	-	K2			80	90	100	112	132	
						KQ		703	704	706		708	710	
						K8						808	810	
						K5		56		140	180		210	
						K3		56		140	180		210	
C.89														
363.00	4	1.450	16 200	0.47	3627/10			✓	✓	✓				2KJ3606 - ■ ■ A 0 ■ - 0 ■ N2
329.73	4.4	1.450	16 200	0.57	3627/11			✓	✓	✓				2KJ3606 - ■ ■ A 0 ■ - 0 ■ M2
295.75	4.9	1.450	16 200	0.78	1183/4			✓	✓	✓	✓	✓		2KJ3606 - ■ ■ A 0 ■ - 0 ■ L2
265.91	5.5	1.450	16 200	0.89	2925/11			✓	✓	✓	✓	✓		2KJ3606 - ■ ■ A 0 ■ - 0 ■ K2
240.50	6	1.450	16 200	1.00	481/2			✓	✓	✓	✓	✓		2KJ3606 - ■ ■ A 0 ■ - 0 ■ J2
222.00	6.5	1.450	16 200	1.18	222/1			✓	✓	✓	✓	✓		2KJ3606 - ■ ■ A 0 ■ - 0 ■ H2
203.36	7.1	1.450	16 200	1.52	2847/14			✓	✓	✓	✓	✓	✓	2KJ3606 - ■ ■ A 0 ■ - 0 ■ G2
170.62	8.5	1.360	16 300	1.67	1365/8			✓	✓	✓	✓	✓	✓	2KJ3606 - ■ ■ A 0 ■ - 0 ■ F2
160.59	9	1.330	16 300	1.91	2730/17			✓	✓	✓	✓	✓	✓	2KJ3606 - ■ ■ A 0 ■ - 0 ■ E2
147.33	9.8	1.280	16 300	2.10	442/3			✓	✓	✓	✓	✓	✓	2KJ3606 - ■ ■ A 0 ■ - 0 ■ D2
128.70	11	1.190	16 300	3.00	1287/10			✓	✓	✓	✓	✓	✓	2KJ3606 - ■ ■ A 0 ■ - 0 ■ C2
115.23	13	1.120	16 000	3.70	2535/22				✓	✓	✓	✓	✓	2KJ3606 - ■ ■ A 0 ■ - 0 ■ B2
100.75	14	1.050	15 300	4.40	403/4				✓	✓	✓	✓	✓	2KJ3606 - ■ ■ A 0 ■ - 0 ■ A2
86.48	17	985	14 600	4.90	1989/23				✓	✓	✓	✓	✓	2KJ3606 - ■ ■ A 0 ■ - 0 ■ X1
76.44	19	930	14 100	6.30	1911/25				✓	✓	✓	✓	✓	2KJ3606 - ■ ■ A 0 ■ - 0 ■ W1
65.00	22	865	13 400	8.10	65/1					✓	✓	✓	✓	2KJ3606 - ■ ■ A 0 ■ - 0 ■ V1
55.61	26	1.450	8 660	0.89	1001/18			✓	✓	✓	✓	✓	✓	2KJ3606 - ■ ■ A 0 ■ - 0 ■ U1
50.00	29	1.430	8 200	1.02	50/1			✓	✓	✓	✓	✓	✓	2KJ3606 - ■ ■ A 0 ■ - 0 ■ T1
45.22	32	1.380	7 940	1.15	407/9			✓	✓	✓	✓	✓	✓	2KJ3606 - ■ ■ A 0 ■ - 0 ■ S1
41.74	35	1.340	7 750	1.35	1628/39			✓	✓	✓	✓	✓	✓	2KJ3606 - ■ ■ A 0 ■ - 0 ■ R1
38.24	38	1.300	7 540	1.72	803/21			✓	✓	✓	✓	✓	✓	2KJ3606 - ■ ■ A 0 ■ - 0 ■ Q1
32.08	45	1.220	7 140	1.97	385/12			✓	✓	✓	✓	✓	✓	2KJ3606 - ■ ■ A 0 ■ - 0 ■ P1
30.20	48	1.200	6 970	2.20	1540/51			✓	✓	✓	✓	✓	✓	2KJ3606 - ■ ■ A 0 ■ - 0 ■ N1
27.70	52	1.140	6 920	2.50	748/27			✓	✓	✓	✓	✓	✓	2KJ3606 - ■ ■ A 0 ■ - 0 ■ M1
25.03	58	1.090	5 540	2.10	876/35			✓	✓	✓	✓	✓	✓	2KJ3606 - ■ ■ A 0 ■ - 0 ■ L1
21.00	69	1.070	4 530	2.40	21/1			✓	✓	✓	✓	✓	✓	2KJ3606 - ■ ■ A 0 ■ - 0 ■ K1
19.76	73	1.120	3 440	2.80	336/17			✓	✓	✓	✓	✓	✓	2KJ3606 - ■ ■ A 0 ■ - 0 ■ J1
18.13	80	1.110	3 130	3.20	272/15			✓	✓	✓	✓	✓	✓	2KJ3606 - ■ ■ A 0 ■ - 0 ■ H1
15.84	92	1.110	4 110	4.40	396/25			✓	✓	✓	✓	✓	✓	2KJ3606 - ■ ■ A 0 ■ - 0 ■ G1
14.18	102	1.070	4 780	5.40	156/11				✓	✓	✓	✓	✓	2KJ3606 - ■ ■ A 0 ■ - 0 ■ F1
12.40	117	1.010	5 460	6.60	62/5				✓	✓	✓	✓	✓	2KJ3606 - ■ ■ A 0 ■ - 0 ■ E1
10.64	136	960	5 610	8.00	1224/115				✓	✓	✓	✓	✓	2KJ3606 - ■ ■ A 0 ■ - 0 ■ D1
9.41	154	915	5 680	10.00	1176/125				✓	✓	✓	✓	✓	2KJ3606 - ■ ■ A 0 ■ - 0 ■ C1
8.00	181	840	5 710	14.00	8/1					✓	✓	✓	✓	2KJ3606 - ■ ■ A 0 ■ - 0 ■ B1
6.86	211	720	5 690	18.00	48/7					✓	✓	✓	✓	2KJ3606 - ■ ■ A 0 ■ - 0 ■ A1

Article No. supplement

Shaft design → Page 9/39

Adapter size

1 or 9

K4	B	C	D	E	F	G	H		4
K2			D	E	F	G	H		2
KQ		A	B	C		D	E		7
K8						A	B		8
K5		A		B	C		D		5
K3		A		B	C		D		3

Adapter type

Gearbox mounting type → Page 9/35

A, D, F or H

SIMOGEAR Gearboxes

Helical worm gearboxes

Efficiencies

Selection and ordering data

i	$n_{mot} = 2\,800\text{ rpm}$				$n_{mot} = 1\,400\text{ rpm}$				$n_{mot} = 900\text{ rpm}$				Article No.
	n_2 rpm	T_{2N} Nm	P_{mot} kW	η %	n_2 rpm	T_{2N} Nm	P_{mot} kW	η %	n_2 rpm	T_{2N} Nm	P_{mot} kW	η %	
C.29													
265.20	10.6	110	0.17	73	5.3	108	0.09	65	3.4	106	0.06	59	2KJ3601 - ■ ■ A 0 ■ - 0 ■ M2
230.10	12.2	110	0.19	74	6.1	108	0.10	67	3.9	106	0.07	61	2KJ3601 - ■ ■ A 0 ■ - 0 ■ L2
209.18	13.4	110	0.21	75	6.7	109	0.11	68	4.3	107	0.08	62	2KJ3601 - ■ ■ A 0 ■ - 0 ■ K2
179.40	15.6	110	0.24	76	7.8	109	0.13	70	5.0	107	0.09	64	2KJ3601 - ■ ■ A 0 ■ - 0 ■ J2
163.09	17.2	110	0.26	76	8.6	110	0.14	71	5.5	108	0.10	65	2KJ3601 - ■ ■ A 0 ■ - 0 ■ H2
143.00	19.6	110	0.30	76	9.8	110	0.16	72	6.3	108	0.11	67	2KJ3601 - ■ ■ A 0 ■ - 0 ■ G2
127.64	22	110	0.33	76	11.0	110	0.17	73	7.1	109	0.12	68	2KJ3601 - ■ ■ A 0 ■ - 0 ■ F2
113.75	25	110	0.38	76	12.3	110	0.19	74	7.9	109	0.13	70	2KJ3601 - ■ ■ A 0 ■ - 0 ■ E2
105.00	27	110	0.41	76	13.3	110	0.21	74	8.6	110	0.14	70	2KJ3601 - ■ ■ A 0 ■ - 0 ■ D2
91.93	30	110	0.46	76	15.2	110	0.23	75	9.8	110	0.16	72	2KJ3601 - ■ ■ A 0 ■ - 0 ■ C2
80.60	35	105	0.51	76	17.4	110	0.27	75	11.2	110	0.18	73	2KJ3601 - ■ ■ A 0 ■ - 0 ■ B2
73.12	38	101	0.53	76	19.1	110	0.29	75	12.3	110	0.19	74	2KJ3601 - ■ ■ A 0 ■ - 0 ■ A2
68.82	41	99	0.56	76	20	110	0.31	75	13.1	110	0.21	74	2KJ3601 - ■ ■ A 0 ■ - 0 ■ X1
60.67	46	95	0.61	75	23	110	0.35	76	14.8	110	0.23	74	2KJ3601 - ■ ■ A 0 ■ - 0 ■ W1
52.65	53	90	0.67	75	27	110	0.41	76	17.1	110	0.26	75	2KJ3601 - ■ ■ A 0 ■ - 0 ■ V1
49.87	56	105	0.69	90	28	102	0.34	87	18	100	0.22	84	2KJ3601 - ■ ■ A 0 ■ - 0 ■ U1
43.27	65	106	0.80	90	32	103	0.39	88	21	101	0.26	86	2KJ3601 - ■ ■ A 0 ■ - 0 ■ T1
39.33	71	106	0.88	90	36	103	0.44	89	23	101	0.28	86	2KJ3601 - ■ ■ A 0 ■ - 0 ■ S1
33.73	83	107	1.00	90	42	104	0.51	89	27	102	0.33	87	2KJ3601 - ■ ■ A 0 ■ - 0 ■ R1
32.64	86	92	0.91	92	43	90	0.45	90	28	88	0.30	87	2KJ3601 - ■ ■ A 0 ■ - 0 ■ Q1
28.32	99	93	1.10	92	49	90	0.51	90	32	89	0.34	88	2KJ3601 - ■ ■ A 0 ■ - 0 ■ P1
25.75	109	93	1.20	92	54	90	0.57	91	35	89	0.37	89	2KJ3601 - ■ ■ A 0 ■ - 0 ■ N1
22.08	127	94	1.40	92	63	91	0.66	91	41	89	0.43	89	2KJ3601 - ■ ■ A 0 ■ - 0 ■ M1
20.07	140	94	1.50	92	70	91	0.74	91	45	90	0.47	90	2KJ3601 - ■ ■ A 0 ■ - 0 ■ L1
17.60	159	93	1.7*	92	80	92	0.85	92	51	90	0.54	90	2KJ3601 - ■ ■ A 0 ■ - 0 ■ K1
15.71	178	89	1.8*	92	89	92	0.95	92	57	91	0.60	91	2KJ3601 - ■ ■ A 0 ■ - 0 ■ J1
14.00	200	86	2.0*	92	100	93	1.10	92	64	91	0.67	91	2KJ3601 - ■ ■ A 0 ■ - 0 ■ H1
12.92	217	83	2.1*	92	108	93	1.20	92	70	91	0.74	91	2KJ3601 - ■ ■ A 0 ■ - 0 ■ G1
11.31	248	79	2.3*	92	124	94	1.30	92	80	92	0.85	91	2KJ3601 - ■ ■ A 0 ■ - 0 ■ F1
9.92	282	74	2.4*	91	141	94	1.50	92	91	92	0.97	91	2KJ3601 - ■ ■ A 0 ■ - 0 ■ E1
9.00	311	71	2.6*	92	156	90	1.6*	92	100	93	1.10	92	2KJ3601 - ■ ■ A 0 ■ - 0 ■ D1
8.47	331	70	2.7*	91	165	88	1.7*	92	106	93	1.10	92	2KJ3601 - ■ ■ A 0 ■ - 0 ■ C1
7.47	375	66	2.8*	91	187	83	1.8*	92	120	93	1.30	92	2KJ3601 - ■ ■ A 0 ■ - 0 ■ B1
6.48	432	62	3.1*	91	216	78	1.9*	92	139	91	1.40	92	2KJ3601 - ■ ■ A 0 ■ - 0 ■ A1

* $P_{mot\ max} = 1.5\text{ kW}$

Selection and ordering data (continued)

i	$n_{\text{mot}} = 700 \text{ rpm}$				$n_{\text{mot}} = 500 \text{ rpm}$				$n_{\text{mot}} = 100 \text{ rpm}$				Article No.
	n_2 rpm	T_{2N} Nm	P_{mot} kW	η %	n_2 rpm	T_{2N} Nm	P_{mot} kW	η %	n_2 rpm	T_{2N} Nm	P_{mot} kW	η %	
C.29													
265.20	2.6	104	<0.06	57	1.9	103	<0.06	54	0.38	95	<0.06	47	2KJ3601 - ■ ■ A 0 ■ - 0 ■ M2
230.10	3	105	0.06	58	2.2	104	<0.06	55	0.43	96	<0.06	48	2KJ3601 - ■ ■ A 0 ■ - 0 ■ L2
209.18	3.3	105	0.06	59	2.4	104	<0.06	56	0.48	97	<0.06	48	2KJ3601 - ■ ■ A 0 ■ - 0 ■ K2
179.40	3.9	106	0.07	61	2.8	105	<0.06	57	0.56	97	<0.06	48	2KJ3601 - ■ ■ A 0 ■ - 0 ■ J2
163.09	4.3	107	0.08	62	3.1	105	0.06	58	0.61	98	<0.06	48	2KJ3601 - ■ ■ A 0 ■ - 0 ■ H2
143.00	4.9	107	0.09	64	3.5	106	0.07	59	0.70	98	<0.06	48	2KJ3601 - ■ ■ A 0 ■ - 0 ■ G2
127.64	5.5	108	0.10	65	3.9	106	0.07	61	0.78	99	<0.06	49	2KJ3601 - ■ ■ A 0 ■ - 0 ■ F2
113.75	6.2	108	0.11	66	4.4	107	0.08	62	0.88	99	<0.06	49	2KJ3601 - ■ ■ A 0 ■ - 0 ■ E2
105.00	6.7	109	0.11	67	4.8	107	0.09	63	0.95	100	<0.06	49	2KJ3601 - ■ ■ A 0 ■ - 0 ■ D2
91.93	7.6	109	0.13	69	5.4	108	0.09	65	1.1	100	<0.06	50	2KJ3601 - ■ ■ A 0 ■ - 0 ■ C2
80.60	8.7	110	0.14	70	6.2	108	0.11	66	1.2	101	<0.06	50	2KJ3601 - ■ ■ A 0 ■ - 0 ■ B2
73.12	9.6	110	0.16	71	6.8	109	0.12	67	1.4	101	<0.06	51	2KJ3601 - ■ ■ A 0 ■ - 0 ■ A2
68.82	10.2	110	0.16	72	7.3	109	0.12	68	1.5	102	<0.06	51	2KJ3601 - ■ ■ A 0 ■ - 0 ■ X1
60.67	11.5	110	0.18	73	8.2	110	0.14	70	1.6	102	<0.06	52	2KJ3601 - ■ ■ A 0 ■ - 0 ■ W1
52.65	13.3	110	0.21	74	9.5	110	0.15	71	1.9	103	<0.06	53	2KJ3601 - ■ ■ A 0 ■ - 0 ■ V1
49.87	14.0	99	0.18	83	10.0	98	0.13	80	2.0	91	<0.06	73	2KJ3601 - ■ ■ A 0 ■ - 0 ■ U1
43.27	16.2	100	0.20	84	11.6	98	0.15	81	2.3	91	<0.06	74	2KJ3601 - ■ ■ A 0 ■ - 0 ■ T1
39.33	17.8	100	0.22	84	12.7	99	0.16	82	2.5	92	<0.06	74	2KJ3601 - ■ ■ A 0 ■ - 0 ■ S1
33.73	21	101	0.26	85	14.8	99	0.19	83	3.0	92	<0.06	74	2KJ3601 - ■ ■ A 0 ■ - 0 ■ R1
32.64	21	87	0.22	86	15.3	86	0.17	84	3.1	80	<0.06	77	2KJ3601 - ■ ■ A 0 ■ - 0 ■ Q1
28.32	25	88	0.27	87	17.7	86	0.19	84	3.5	80	<0.06	78	2KJ3601 - ■ ■ A 0 ■ - 0 ■ P1
25.75	27	88	0.29	87	19.4	87	0.21	85	3.9	81	<0.06	78	2KJ3601 - ■ ■ A 0 ■ - 0 ■ N1
22.08	32	89	0.34	88	23	87	0.25	86	4.5	81	<0.06	78	2KJ3601 - ■ ■ A 0 ■ - 0 ■ M1
20.07	35	89	0.37	89	25	88	0.27	87	5.0	82	<0.06	79	2KJ3601 - ■ ■ A 0 ■ - 0 ■ L1
17.60	40	89	0.42	89	28	88	0.30	87	5.7	82	0.06	79	2KJ3601 - ■ ■ A 0 ■ - 0 ■ K1
15.71	45	90	0.47	90	32	89	0.34	88	6.4	83	0.07	79	2KJ3601 - ■ ■ A 0 ■ - 0 ■ J1
14.00	50	90	0.53	90	36	89	0.38	89	7.1	83	0.08	80	2KJ3601 - ■ ■ A 0 ■ - 0 ■ H1
12.92	54	90	0.57	90	39	89	0.41	89	7.7	83	0.08	80	2KJ3601 - ■ ■ A 0 ■ - 0 ■ G1
11.31	62	91	0.65	91	44	90	0.46	90	8.8	84	0.10	81	2KJ3601 - ■ ■ A 0 ■ - 0 ■ F1
9.92	71	91	0.75	91	50	90	0.53	90	10.1	84	0.11	81	2KJ3601 - ■ ■ A 0 ■ - 0 ■ E1
9.00	78	92	0.82	91	56	91	0.59	91	11.1	85	0.12	82	2KJ3601 - ■ ■ A 0 ■ - 0 ■ D1
8.47	83	92	0.88	91	59	91	0.62	91	11.8	85	0.13	82	2KJ3601 - ■ ■ A 0 ■ - 0 ■ C1
7.47	94	93	1.00	92	67	91	0.71	91	13.4	85	0.15	83	2KJ3601 - ■ ■ A 0 ■ - 0 ■ B1
6.48	108	93	1.20	92	77	92	0.81	91	15.4	86	0.17	84	2KJ3601 - ■ ■ A 0 ■ - 0 ■ A1

SIMOGEAR Gearboxes

Helical worm gearboxes

Efficiencies

Selection and ordering data (continued)

i	$n_{mot} = 2\,800\text{ rpm}$				$n_{mot} = 1\,400\text{ rpm}$				$n_{mot} = 900\text{ rpm}$				Article No.
	n_2 rpm	T_{2N} Nm	P_{mot} kW	η %	n_2 rpm	T_{2N} Nm	P_{mot} kW	η %	n_2 rpm	T_{2N} Nm	P_{mot} kW	η %	
C.39													
299.00	9.4	194	0.27	71	4.7	192	0.15	64	3.0	189	0.10	58	2KJ3602 - ■ ■ A 0 ■ - 0 ■ N2
265.20	10.6	194	0.30	72	5.3	192	0.16	66	3.4	190	0.11	60	2KJ3602 - ■ ■ A 0 ■ - 0 ■ M2
230.10	12.2	194	0.34	73	6.1	193	0.18	68	3.9	191	0.13	62	2KJ3602 - ■ ■ A 0 ■ - 0 ■ L2
209.18	13.4	194	0.38	73	6.7	193	0.20	68	4.3	191	0.14	63	2KJ3602 - ■ ■ A 0 ■ - 0 ■ K2
179.40	15.6	194	0.44	73	7.8	193	0.23	70	5.0	192	0.16	65	2KJ3602 - ■ ■ A 0 ■ - 0 ■ J2
163.09	17.2	194	0.48	73	8.6	193	0.25	71	5.5	192	0.17	66	2KJ3602 - ■ ■ A 0 ■ - 0 ■ H2
143.00	19.6	194	0.55	73	9.8	194	0.28	71	6.3	193	0.19	68	2KJ3602 - ■ ■ A 0 ■ - 0 ■ G2
127.64	22	194	0.61	73	11	194	0.31	72	7.1	193	0.21	69	2KJ3602 - ■ ■ A 0 ■ - 0 ■ F2
113.75	25	181	0.66	73	12.3	194	0.35	72	7.9	193	0.23	70	2KJ3602 - ■ ■ A 0 ■ - 0 ■ E2
105.00	27	175	0.68	73	13.3	194	0.37	72	8.6	193	0.25	70	2KJ3602 - ■ ■ A 0 ■ - 0 ■ D2
91.93	30	165	0.72	72	15.2	194	0.43	72	9.8	194	0.28	71	2KJ3602 - ■ ■ A 0 ■ - 0 ■ C2
80.60	35	157	0.80	72	17.4	194	0.49	73	11.2	194	0.32	72	2KJ3602 - ■ ■ A 0 ■ - 0 ■ B2
73.12	38	150	0.84	72	19.1	189	0.52	73	12.3	194	0.35	72	2KJ3602 - ■ ■ A 0 ■ - 0 ■ A2
68.82	41	147	0.88	72	20	185	0.53	73	13.1	194	0.37	72	2KJ3602 - ■ ■ A 0 ■ - 0 ■ X1
60.67	46	139	0.94	72	23	175	0.58	73	14.8	194	0.41	73	2KJ3602 - ■ ■ A 0 ■ - 0 ■ W1
52.65	53	131	1.00	72	27	166	0.65	73	17.1	192	0.47	73	2KJ3602 - ■ ■ A 0 ■ - 0 ■ V1
49.87	56	195	1.30	89	28	198	0.66	89	18	194	0.41	89	2KJ3602 - ■ ■ A 0 ■ - 0 ■ U1
43.27	65	196	1.50	89	32	199	0.75	89	21	196	0.49	89	2KJ3602 - ■ ■ A 0 ■ - 0 ■ T1
39.33	71	196	1.60	89	36	200	0.85	89	23	196	0.53	89	2KJ3602 - ■ ■ A 0 ■ - 0 ■ S1
33.73	83	196	1.90	89	42	200	1.00	89	27	197	0.63	89	2KJ3602 - ■ ■ A 0 ■ - 0 ■ R1
32.64	86	200	2.00	91	43	210	1.00	91	28	205	0.68	90	2KJ3602 - ■ ■ A 0 ■ - 0 ■ Q1
28.32	99	200	2.30	91	49	225	1.30	91	32	225	0.84	90	2KJ3602 - ■ ■ A 0 ■ - 0 ■ P1
25.75	109	200	2.50	91	54	235	1.50	91	35	230	0.95	90	2KJ3602 - ■ ■ A 0 ■ - 0 ■ N1
22.08	127	198	2.90	91	63	235	1.70	91	41	230	1.10	91	2KJ3602 - ■ ■ A 0 ■ - 0 ■ M1
20.07	140	188	3.00	91	70	235	1.90	91	45	235	1.20	91	2KJ3602 - ■ ■ A 0 ■ - 0 ■ L1
17.60	159	180	3.3*	91	80	225	2.10	92	51	235	1.40	91	2KJ3602 - ■ ■ A 0 ■ - 0 ■ K1
15.71	178	172	3.5*	91	89	215	2.20	91	57	235	1.60	91	2KJ3602 - ■ ■ A 0 ■ - 0 ■ J1
14.00	200	164	3.8*	91	100	205	2.40	91	64	235	1.70	92	2KJ3602 - ■ ■ A 0 ■ - 0 ■ H1
12.92	217	159	4.0*	91	108	200	2.50	92	70	230	1.90	92	2KJ3602 - ■ ■ A 0 ■ - 0 ■ G1
11.31	248	152	4.3*	91	124	192	2.70	91	80	220	2.00	92	2KJ3602 - ■ ■ A 0 ■ - 0 ■ F1
9.92	282	145	4.7*	91	141	183	3.00	91	91	210	2.20	92	2KJ3602 - ■ ■ A 0 ■ - 0 ■ E1
9.00	311	137	4.9*	91	156	177	3.2*	91	100	205	2.30	92	2KJ3602 - ■ ■ A 0 ■ - 0 ■ D1
8.47	331	129	4.9*	91	165	173	3.3*	91	106	200	2.40	92	2KJ3602 - ■ ■ A 0 ■ - 0 ■ C1
7.47	375	114	4.9*	91	187	166	3.6*	91	120	192	2.60	92	2KJ3602 - ■ ■ A 0 ■ - 0 ■ B1
6.48	432	99	4.9*	91	216	157	3.9*	91	139	182	2.90	92	2KJ3602 - ■ ■ A 0 ■ - 0 ■ A1

* $P_{mot\ max} = 3\text{ kW}$

Selection and ordering data (continued)

i	$n_{mot} = 700 \text{ rpm}$				$n_{mot} = 500 \text{ rpm}$				$n_{mot} = 100 \text{ rpm}$				Article No.
	n_2 rpm	T_{2N} Nm	P_{mot} kW	η %	n_2 rpm	T_{2N} Nm	P_{mot} kW	η %	n_2 rpm	T_{2N} Nm	P_{mot} kW	η %	
C.39													
299.00	2.3	187	0.08	55	1.7	184	0.06	52	0.33	170	<0.06	44	2KJ3602 - ■ ■ A 0 ■ - 0 ■ N2
265.20	2.6	188	0.09	57	1.9	185	0.07	53	0.38	167	<0.06	44	2KJ3602 - ■ ■ A 0 ■ - 0 ■ M2
230.10	3.0	189	0.10	58	2.2	186	0.08	54	0.43	164	<0.06	44	2KJ3602 - ■ ■ A 0 ■ - 0 ■ L2
209.18	3.3	190	0.11	59	2.4	187	0.09	55	0.48	162	<0.06	44	2KJ3602 - ■ ■ A 0 ■ - 0 ■ K2
179.40	3.9	191	0.13	62	2.8	188	0.10	57	0.56	160	<0.06	45	2KJ3602 - ■ ■ A 0 ■ - 0 ■ J2
163.09	4.3	191	0.14	63	3.1	189	0.11	58	0.61	160	<0.06	45	2KJ3602 - ■ ■ A 0 ■ - 0 ■ H2
143.00	4.9	192	0.15	64	3.5	190	0.12	60	0.70	160	<0.06	46	2KJ3602 - ■ ■ A 0 ■ - 0 ■ G2
127.64	5.5	192	0.17	66	3.9	191	0.13	61	0.78	161	<0.06	46	2KJ3602 - ■ ■ A 0 ■ - 0 ■ F2
113.75	6.2	193	0.19	67	4.4	191	0.14	63	0.88	162	<0.06	47	2KJ3602 - ■ ■ A 0 ■ - 0 ■ E2
105.00	6.7	193	0.20	68	4.8	192	0.15	64	0.95	163	<0.06	47	2KJ3602 - ■ ■ A 0 ■ - 0 ■ D2
91.93	7.6	193	0.22	69	5.4	192	0.17	66	1.1	166	<0.06	48	2KJ3602 - ■ ■ A 0 ■ - 0 ■ C2
80.60	8.7	193	0.25	70	6.2	193	0.19	67	1.2	168	<0.06	49	2KJ3602 - ■ ■ A 0 ■ - 0 ■ B2
73.12	9.6	194	0.28	71	6.8	193	0.20	68	1.4	170	<0.06	49	2KJ3602 - ■ ■ A 0 ■ - 0 ■ A2
68.82	10.2	194	0.29	71	7.3	193	0.21	69	1.5	172	<0.06	50	2KJ3602 - ■ ■ A 0 ■ - 0 ■ X1
60.67	11.5	194	0.32	72	8.2	193	0.24	70	1.6	176	0.06	51	2KJ3602 - ■ ■ A 0 ■ - 0 ■ W1
52.65	13.3	194	0.37	73	9.5	194	0.27	71	1.9	180	0.07	53	2KJ3602 - ■ ■ A 0 ■ - 0 ■ V1
49.87	14.0	192	0.32	88	10.0	190	0.23	86	2.0	177	0.06	66	2KJ3602 - ■ ■ A 0 ■ - 0 ■ U1
43.27	16.2	194	0.37	88	11.6	191	0.27	87	2.3	178	0.06	67	2KJ3602 - ■ ■ A 0 ■ - 0 ■ T1
39.33	17.8	194	0.41	88	12.7	192	0.29	88	2.5	179	0.07	68	2KJ3602 - ■ ■ A 0 ■ - 0 ■ S1
33.73	21	196	0.49	89	14.8	193	0.34	88	3.0	180	0.08	71	2KJ3602 - ■ ■ A 0 ■ - 0 ■ R1
32.64	21	200	0.51	88	15.3	197	0.37	86	3.1	174	0.08	76	2KJ3602 - ■ ■ A 0 ■ - 0 ■ Q1
28.32	25	220	0.66	89	17.7	215	0.47	87	3.5	192	0.09	76	2KJ3602 - ■ ■ A 0 ■ - 0 ■ P1
25.75	27	230	0.73	89	19.4	225	0.53	87	3.9	210	0.11	77	2KJ3602 - ■ ■ A 0 ■ - 0 ■ N1
22.08	32	230	0.86	90	23	225	0.62	88	4.5	210	0.13	77	2KJ3602 - ■ ■ A 0 ■ - 0 ■ M1
20.07	35	230	0.94	90	25	230	0.68	89	5.0	215	0.15	78	2KJ3602 - ■ ■ A 0 ■ - 0 ■ L1
17.60	40	230	1.10	91	28	230	0.76	90	5.7	215	0.16	79	2KJ3602 - ■ ■ A 0 ■ - 0 ■ K1
15.71	45	235	1.20	91	32	230	0.86	90	6.4	215	0.18	79	2KJ3602 - ■ ■ A 0 ■ - 0 ■ J1
14.00	50	235	1.40	91	36	230	0.97	91	7.1	215	0.20	80	2KJ3602 - ■ ■ A 0 ■ - 0 ■ H1
12.92	54	235	1.50	92	39	230	1.10	91	7.7	215	0.22	81	2KJ3602 - ■ ■ A 0 ■ - 0 ■ G1
11.31	62	235	1.70	92	44	235	1.20	91	8.8	220	0.25	82	2KJ3602 - ■ ■ A 0 ■ - 0 ■ F1
9.92	71	230	1.90	92	50	235	1.40	91	10.1	220	0.28	83	2KJ3602 - ■ ■ A 0 ■ - 0 ■ E1
9.00	78	220	2.00	92	56	235	1.50	92	11.1	220	0.31	83	2KJ3602 - ■ ■ A 0 ■ - 0 ■ D1
8.47	83	215	2.10	92	59	235	1.60	92	11.8	220	0.33	84	2KJ3602 - ■ ■ A 0 ■ - 0 ■ C1
7.47	94	205	2.30	92	67	230	1.80	92	13.4	220	0.37	85	2KJ3602 - ■ ■ A 0 ■ - 0 ■ B1
6.48	108	198	2.50	92	77	220	2.00	92	15.4	225	0.42	86	2KJ3602 - ■ ■ A 0 ■ - 0 ■ A1

SIMOGEAR Gearboxes

Helical worm gearboxes

Efficiencies

Selection and ordering data (continued)

i	$n_{mot} = 2\,800\text{ rpm}$				$n_{mot} = 1\,400\text{ rpm}$				$n_{mot} = 900\text{ rpm}$				Article No.
	n_2 rpm	T_{2N} Nm	P_{mot} kW	η %	n_2 rpm	T_{2N} Nm	P_{mot} kW	η %	n_2 rpm	T_{2N} Nm	P_{mot} kW	η %	
C.49													
299.00	9.4	355	0.48	73	4.7	350	0.26	67	3.0	345	0.18	61	2KJ3603 - ■ ■ A 0 ■ - 0 ■ N2
265.20	10.6	355	0.54	74	5.3	350	0.29	69	3.4	350	0.20	63	2KJ3603 - ■ ■ A 0 ■ - 0 ■ M2
230.10	12.2	355	0.62	74	6.1	350	0.32	70	3.9	350	0.22	65	2KJ3603 - ■ ■ A 0 ■ - 0 ■ L2
209.18	13.4	355	0.68	74	6.7	355	0.35	71	4.3	350	0.24	66	2KJ3603 - ■ ■ A 0 ■ - 0 ■ K2
179.40	15.6	355	0.79	74	7.8	355	0.40	72	5.0	350	0.27	68	2KJ3603 - ■ ■ A 0 ■ - 0 ■ J2
163.09	17.2	340	0.84	74	8.6	355	0.44	73	5.5	350	0.30	69	2KJ3603 - ■ ■ A 0 ■ - 0 ■ H2
143.00	19.6	315	0.89	74	9.8	355	0.50	73	6.3	355	0.33	70	2KJ3603 - ■ ■ A 0 ■ - 0 ■ G2
127.64	22	300	0.95	73	11.0	355	0.56	73	7.1	355	0.37	71	2KJ3603 - ■ ■ A 0 ■ - 0 ■ F2
113.75	25	285	1.00	73	12.3	355	0.62	74	7.9	355	0.41	72	2KJ3603 - ■ ■ A 0 ■ - 0 ■ E2
105.00	27	275	1.10	73	13.3	350	0.66	74	8.6	355	0.44	72	2KJ3603 - ■ ■ A 0 ■ - 0 ■ D2
91.93	30	260	1.10	73	15.2	330	0.72	74	9.8	355	0.50	73	2KJ3603 - ■ ■ A 0 ■ - 0 ■ C2
80.60	35	250	1.30	73	17.4	315	0.78	74	11.2	355	0.57	74	2KJ3603 - ■ ■ A 0 ■ - 0 ■ B2
73.12	38	240	1.30	73	19.1	300	0.82	74	12.3	345	0.61	74	2KJ3603 - ■ ■ A 0 ■ - 0 ■ A2
68.82	41	230	1.40	73	20	295	0.84	74	13.1	340	0.63	74	2KJ3603 - ■ ■ A 0 ■ - 0 ■ X1
60.67	46	220	1.50	73	23	280	0.92	74	14.8	320	0.68	74	2KJ3603 - ■ ■ A 0 ■ - 0 ■ W1
52.65	53	210	1.60	73	27	265	1.00	74	17.1	305	0.74	74	2KJ3603 - ■ ■ A 0 ■ - 0 ■ V1
49.87	56	310	2.10	90	28	310	1.00	89	18	305	0.66	87	2KJ3603 - ■ ■ A 0 ■ - 0 ■ U1
43.27	65	340	2.60	90	32	340	1.30	89	21	335	0.85	88	2KJ3603 - ■ ■ A 0 ■ - 0 ■ T1
39.33	71	335	2.80	89	36	395	1.70	89	23	395	1.10	88	2KJ3603 - ■ ■ A 0 ■ - 0 ■ S1
33.73	83	315	3.10	89	42	365	1.80	90	27	365	1.20	89	2KJ3603 - ■ ■ A 0 ■ - 0 ■ R1
30.67	91	300	3.20	89	46	380	2.10	89	29	400	1.40	89	2KJ3603 - ■ ■ A 0 ■ - 0 ■ Q1
26.89	104	285	3.50	89	52	360	2.20	90	33	400	1.50	89	2KJ3603 - ■ ■ A 0 ■ - 0 ■ P1
24.00	117	275	3.80	89	58	345	2.40	90	38	400	1.80	90	2KJ3603 - ■ ■ A 0 ■ - 0 ■ N1
21.39	131	260	4.1*	89	65	330	2.50	90	42	385	1.90	90	2KJ3603 - ■ ■ A 0 ■ - 0 ■ M1
19.74	142	255	4.3*	89	71	320	2.70	90	46	370	2.00	90	2KJ3603 - ■ ■ A 0 ■ - 0 ■ L1
17.29	162	240	4.6*	89	81	305	2.90	90	52	355	2.20	90	2KJ3603 - ■ ■ A 0 ■ - 0 ■ K1
15.16	185	230	5.1*	89	92	290	3.20	90	59	335	2.30	90	2KJ3603 - ■ ■ A 0 ■ - 0 ■ J1
13.75	204	220	5.4*	89	102	280	3.40	90	65	325	2.50	90	2KJ3603 - ■ ■ A 0 ■ - 0 ■ H1
12.94	216	210	5.3*	89	108	275	3.50	90	70	315	2.60	90	2KJ3603 - ■ ■ A 0 ■ - 0 ■ G1
11.41	245	185	5.4*	89	123	260	3.80	90	79	305	2.80	90	2KJ3603 - ■ ■ A 0 ■ - 0 ■ F1
9.90	283	161	5.4*	89	141	250	4.1*	89	91	290	3.10	90	2KJ3603 - ■ ■ A 0 ■ - 0 ■ E1
9.00	311	185	6.6*	91	156	260	4.6*	92	100	260	3.00	92	2KJ3603 - ■ ■ A 0 ■ - 0 ■ D1
8.47	331	174	6.6*	91	165	260	4.9*	92	106	260	3.20	92	2KJ3603 - ■ ■ A 0 ■ - 0 ■ C1
7.47	375	153	6.6*	91	187	250	5.3*	92	120	260	3.60	92	2KJ3603 - ■ ■ A 0 ■ - 0 ■ B1
6.48	432	133	6.6*	91	216	235	5.8*	92	139	260	4.1*	92	2KJ3603 - ■ ■ A 0 ■ - 0 ■ A1

* $P_{mot\ max} = 4\text{ kW}$

Selection and ordering data (continued)

i	$n_{\text{mot}} = 700 \text{ rpm}$				$n_{\text{mot}} = 500 \text{ rpm}$				$n_{\text{mot}} = 100 \text{ rpm}$				Article No.
	n_2 rpm	T_{2N} Nm	P_{mot} kW	η %	n_2 rpm	T_{2N} Nm	P_{mot} kW	η %	n_2 rpm	T_{2N} Nm	P_{mot} kW	η %	
C.49													
299.00	2.3	340	0.14	58	1.7	315	0.10	54	0.33	260	<0.06	45	2KJ3603 - ■ ■ A 0 ■ - 0 ■ N2
265.20	2.6	340	0.16	60	1.9	315	0.11	55	0.38	255	<0.06	45	2KJ3603 - ■ ■ A 0 ■ - 0 ■ M2
230.10	3.0	345	0.18	61	2.2	320	0.13	57	0.43	255	<0.06	45	2KJ3603 - ■ ■ A 0 ■ - 0 ■ L2
209.18	3.3	345	0.19	63	2.4	320	0.14	58	0.48	255	<0.06	45	2KJ3603 - ■ ■ A 0 ■ - 0 ■ K2
179.40	3.9	350	0.22	65	2.8	330	0.16	60	0.56	255	<0.06	46	2KJ3603 - ■ ■ A 0 ■ - 0 ■ J2
163.09	4.3	350	0.24	66	3.1	330	0.18	61	0.61	255	<0.06	46	2KJ3603 - ■ ■ A 0 ■ - 0 ■ H2
143.00	4.9	350	0.27	68	3.5	340	0.20	63	0.70	255	<0.06	47	2KJ3603 - ■ ■ A 0 ■ - 0 ■ G2
127.64	5.5	350	0.30	69	3.9	350	0.22	65	0.78	260	<0.06	47	2KJ3603 - ■ ■ A 0 ■ - 0 ■ F2
113.75	6.2	355	0.33	70	4.4	350	0.25	66	0.88	260	<0.06	48	2KJ3603 - ■ ■ A 0 ■ - 0 ■ E2
105.00	6.7	355	0.35	71	4.8	350	0.26	67	0.95	265	<0.06	49	2KJ3603 - ■ ■ A 0 ■ - 0 ■ D2
91.93	7.6	355	0.39	72	5.4	350	0.29	69	1.1	270	0.06	50	2KJ3603 - ■ ■ A 0 ■ - 0 ■ C2
80.60	8.7	355	0.45	73	6.2	355	0.33	70	1.2	275	0.07	51	2KJ3603 - ■ ■ A 0 ■ - 0 ■ B2
73.12	9.6	355	0.49	73	6.8	355	0.36	71	1.4	280	0.08	52	2KJ3603 - ■ ■ A 0 ■ - 0 ■ A2
68.82	10.2	355	0.52	73	7.3	355	0.38	72	1.5	280	0.08	52	2KJ3603 - ■ ■ A 0 ■ - 0 ■ X1
60.67	11.5	350	0.57	74	8.2	355	0.42	73	1.6	285	0.09	54	2KJ3603 - ■ ■ A 0 ■ - 0 ■ W1
52.65	13.3	330	0.63	74	9.5	355	0.48	73	1.9	295	0.11	55	2KJ3603 - ■ ■ A 0 ■ - 0 ■ V1
49.87	14.0	295	0.51	86	10.0	285	0.37	83	2.0	245	0.07	71	2KJ3603 - ■ ■ A 0 ■ - 0 ■ U1
43.27	16.2	330	0.65	87	11.6	320	0.47	84	2.3	275	0.09	71	2KJ3603 - ■ ■ A 0 ■ - 0 ■ T1
39.33	17.8	390	0.83	87	12.7	375	0.60	85	2.5	320	0.12	72	2KJ3603 - ■ ■ A 0 ■ - 0 ■ S1
33.73	21	360	0.91	88	14.8	355	0.64	86	3.0	300	0.13	73	2KJ3603 - ■ ■ A 0 ■ - 0 ■ R1
30.67	23	395	1.10	88	16.3	385	0.77	87	3.3	330	0.16	73	2KJ3603 - ■ ■ A 0 ■ - 0 ■ Q1
26.89	26	395	1.20	89	18.6	390	0.87	88	3.7	330	0.17	74	2KJ3603 - ■ ■ A 0 ■ - 0 ■ P1
24.00	29	395	1.40	89	21	390	0.99	88	4.2	335	0.20	75	2KJ3603 - ■ ■ A 0 ■ - 0 ■ N1
21.39	33	395	1.50	89	23	395	1.10	89	4.7	340	0.22	76	2KJ3603 - ■ ■ A 0 ■ - 0 ■ M1
19.74	35	400	1.60	90	25	395	1.20	89	5.1	340	0.24	77	2KJ3603 - ■ ■ A 0 ■ - 0 ■ L1
17.29	40	385	1.80	90	29	395	1.30	89	5.8	345	0.27	78	2KJ3603 - ■ ■ A 0 ■ - 0 ■ K1
15.16	46	365	2.00	90	33	390	1.50	90	6.6	345	0.30	79	2KJ3603 - ■ ■ A 0 ■ - 0 ■ J1
13.75	51	355	2.10	90	36	390	1.60	90	7.3	345	0.33	80	2KJ3603 - ■ ■ A 0 ■ - 0 ■ H1
12.94	54	345	2.20	90	39	385	1.80	90	7.7	350	0.35	80	2KJ3603 - ■ ■ A 0 ■ - 0 ■ G1
11.41	61	330	2.40	90	44	370	1.90	90	8.8	355	0.40	82	2KJ3603 - ■ ■ A 0 ■ - 0 ■ F1
9.90	71	315	2.60	90	51	350	2.10	90	10.1	360	0.46	83	2KJ3603 - ■ ■ A 0 ■ - 0 ■ E1
9.00	78	260	2.30	92	56	255	1.70	91	11.1	235	0.33	84	2KJ3603 - ■ ■ A 0 ■ - 0 ■ D1
8.47	83	260	2.50	92	59	260	1.80	91	11.8	240	0.35	84	2KJ3603 - ■ ■ A 0 ■ - 0 ■ C1
7.47	94	260	2.80	92	67	260	2.00	92	13.4	240	0.40	85	2KJ3603 - ■ ■ A 0 ■ - 0 ■ B1
6.48	108	260	3.20	92	77	260	2.30	92	15.4	245	0.46	87	2KJ3603 - ■ ■ A 0 ■ - 0 ■ A1

SIMOGEAR Gearboxes

Helical worm gearboxes

Efficiencies

Selection and ordering data (continued)

i	$n_{mot} = 2\,800\text{ rpm}$				$n_{mot} = 1\,400\text{ rpm}$				$n_{mot} = 900\text{ rpm}$				Article No.
	n_2 rpm	T_{2N} Nm	P_{mot} kW	η %	n_2 rpm	T_{2N} Nm	P_{mot} kW	η %	n_2 rpm	T_{2N} Nm	P_{mot} kW	η %	
C.69													
360.00	7.8	575	0.65	73	3.9	680	0.40	69	2.5	645	0.27	63	2KJ3604 - ■ ■ ■ A 0 ■ - 0 ■ M2
319.80	8.8	570	0.72	73	4.4	680	0.45	70	2.8	655	0.30	65	2KJ3604 - ■ ■ ■ A 0 ■ - 0 ■ L2
280.80	10.0	560	0.81	73	5.0	680	0.50	71	3.2	660	0.33	66	2KJ3604 - ■ ■ ■ A 0 ■ - 0 ■ K2
255.27	11.0	555	0.88	73	5.5	680	0.55	72	3.5	665	0.36	67	2KJ3604 - ■ ■ ■ A 0 ■ - 0 ■ J2
218.40	12.8	530	0.97	74	6.4	655	0.60	73	4.1	675	0.42	70	2KJ3604 - ■ ■ ■ A 0 ■ - 0 ■ H2
198.55	14.1	510	1.00	73	7.1	635	0.65	73	4.5	680	0.46	70	2KJ3604 - ■ ■ ■ A 0 ■ - 0 ■ G2
175.50	16.0	485	1.10	73	8.0	610	0.70	74	5.1	685	0.51	72	2KJ3604 - ■ ■ ■ A 0 ■ - 0 ■ F2
159.55	17.5	470	1.20	73	8.8	590	0.74	74	5.6	670	0.54	72	2KJ3604 - ■ ■ ■ A 0 ■ - 0 ■ E2
139.75	20	440	1.30	73	10.0	550	0.79	74	6.4	630	0.58	73	2KJ3604 - ■ ■ ■ A 0 ■ - 0 ■ D2
129.00	22	425	1.30	74	10.9	535	0.83	74	7.0	610	0.61	73	2KJ3604 - ■ ■ ■ A 0 ■ - 0 ■ C2
114.21	25	405	1.40	73	12.3	510	0.89	74	7.9	585	0.66	74	2KJ3604 - ■ ■ ■ A 0 ■ - 0 ■ B2
102.50	27	555	1.80	87	13.7	645	1.10	86	8.8	625	0.69	84	2KJ3604 - ■ ■ ■ A 0 ■ - 0 ■ A2
90.00	31	555	2.10	87	15.6	665	1.30	86	10.0	650	0.81	84	2KJ3604 - ■ ■ ■ A 0 ■ - 0 ■ X1
81.82	34	545	2.20	87	17.1	680	1.40	87	11.0	775	1.10	85	2KJ3604 - ■ ■ ■ A 0 ■ - 0 ■ W1
70.00	40	515	2.50	87	20	650	1.60	87	12.9	680	1.10	86	2KJ3604 - ■ ■ ■ A 0 ■ - 0 ■ V1
63.64	44	500	2.70	87	22	630	1.70	87	14.1	720	1.20	86	2KJ3604 - ■ ■ ■ A 0 ■ - 0 ■ U1
56.25	50	480	2.90	87	25	605	1.80	87	16.0	695	1.30	87	2KJ3604 - ■ ■ ■ A 0 ■ - 0 ■ T1
51.14	55	455	3.00	87	27	575	1.90	87	17.6	660	1.40	87	2KJ3604 - ■ ■ ■ A 0 ■ - 0 ■ S1
44.79	63	430	3.30	87	31	545	2.00	87	20	630	1.50	87	2KJ3604 - ■ ■ ■ A 0 ■ - 0 ■ R1
41.35	68	420	3.40	87	34	525	2.20	87	22	610	1.60	87	2KJ3604 - ■ ■ ■ A 0 ■ - 0 ■ Q1
36.61	76	400	3.70	87	38	505	2.30	87	25	580	1.80	87	2KJ3604 - ■ ■ ■ A 0 ■ - 0 ■ P1
30.00	93	435	4.70	90	47	545	3.00	90	30	560	2.00	90	2KJ3604 - ■ ■ ■ A 0 ■ - 0 ■ N1
26.28	107	410	5.10	90	53	520	3.20	90	34	550	2.20	90	2KJ3604 - ■ ■ ■ A 0 ■ - 0 ■ M1
24.26	115	400	5.30	90	58	500	3.40	90	37	545	2.30	91	2KJ3604 - ■ ■ ■ A 0 ■ - 0 ■ L1
21.48	130	380	5.8*	90	65	480	3.60	90	42	540	2.60	91	2KJ3604 - ■ ■ ■ A 0 ■ - 0 ■ K1
17.88	157	355	6.5*	90	78	450	4.10	90	50	520	3.00	91	2KJ3604 - ■ ■ ■ A 0 ■ - 0 ■ J1
15.88	176	365	7.3*	92	88	365	3.70	92	57	365	2.40	92	2KJ3604 - ■ ■ ■ A 0 ■ - 0 ■ H1
14.06	199	360	8.2*	92	100	360	4.10	92	64	360	2.60	92	2KJ3604 - ■ ■ ■ A 0 ■ - 0 ■ G1
11.70	239	345	9.5*	92	120	365	5.00	92	77	365	3.20	92	2KJ3604 - ■ ■ ■ A 0 ■ - 0 ■ F1
11.01	254	325	9.5*	92	127	365	5.40	92	82	365	3.50	92	2KJ3604 - ■ ■ ■ A 0 ■ - 0 ■ E1
9.87	284	290	9.5*	92	142	365	6.0*	92	91	365	3.80	92	2KJ3604 - ■ ■ ■ A 0 ■ - 0 ■ D1
8.40	333	250	9.6*	91	167	370	7.1*	92	107	370	4.50	92	2KJ3604 - ■ ■ ■ A 0 ■ - 0 ■ C1
7.20	389	210	9.6*	91	194	365	8.2*	92	125	365	5.30	92	2KJ3604 - ■ ■ ■ A 0 ■ - 0 ■ B1
6.20	452	184	9.6*	91	226	365	9.4*	92	145	365	6.1*	92	2KJ3604 - ■ ■ ■ A 0 ■ - 0 ■ A1

* $P_{mot\ max} = 5.5\text{ kW}$

Selection and ordering data (continued)

i	$n_{mot} = 700$ rpm				$n_{mot} = 500$ rpm				$n_{mot} = 100$ rpm				Article No.
	n_2 rpm	T_{2N} Nm	P_{mot} kW	η %	n_2 rpm	T_{2N} Nm	P_{mot} kW	η %	n_2 rpm	T_{2N} Nm	P_{mot} kW	η %	
C.69													
360.00	1.9	610	0.20	60	1.4	570	0.15	55	0.28	460	<0.06	45	2KJ3604 - ■ ■ ■ A 0 ■ - 0 ■ M2
319.80	2.2	620	0.23	61	1.6	575	0.17	57	0.31	460	<0.06	45	2KJ3604 - ■ ■ ■ A 0 ■ - 0 ■ L2
280.80	2.5	625	0.26	63	1.8	580	0.19	58	0.36	455	<0.06	45	2KJ3604 - ■ ■ ■ A 0 ■ - 0 ■ K2
255.27	2.7	635	0.28	64	2.0	590	0.21	59	0.39	455	<0.06	45	2KJ3604 - ■ ■ ■ A 0 ■ - 0 ■ J2
218.40	3.2	645	0.33	66	2.3	605	0.24	62	0.46	460	<0.06	46	2KJ3604 - ■ ■ ■ A 0 ■ - 0 ■ H2
198.55	3.5	650	0.35	68	2.5	610	0.25	63	0.50	455	<0.06	47	2KJ3604 - ■ ■ ■ A 0 ■ - 0 ■ G2
175.50	4.0	665	0.40	69	2.8	625	0.28	65	0.57	460	0.06	48	2KJ3604 - ■ ■ ■ A 0 ■ - 0 ■ F2
159.55	4.4	670	0.44	70	3.1	635	0.31	66	0.63	465	0.06	48	2KJ3604 - ■ ■ ■ A 0 ■ - 0 ■ E2
139.75	5.0	670	0.49	72	3.6	650	0.36	68	0.72	475	0.07	49	2KJ3604 - ■ ■ ■ A 0 ■ - 0 ■ D2
129.00	5.4	655	0.51	72	3.9	660	0.39	69	0.78	480	0.08	50	2KJ3604 - ■ ■ ■ A 0 ■ - 0 ■ C2
114.21	6.1	630	0.55	73	4.4	670	0.44	71	0.88	490	0.09	51	2KJ3604 - ■ ■ ■ A 0 ■ - 0 ■ B2
102.50	6.8	610	0.54	81	4.9	585	0.39	78	0.98	500	0.08	67	2KJ3604 - ■ ■ ■ A 0 ■ - 0 ■ A2
90.00	7.8	635	0.63	82	5.6	610	0.45	79	1.1	515	0.09	67	2KJ3604 - ■ ■ ■ A 0 ■ - 0 ■ X1
81.82	8.6	800	0.87	84	6.1	775	0.62	80	1.2	650	0.12	68	2KJ3604 - ■ ■ ■ A 0 ■ - 0 ■ W1
70.00	10.0	665	0.83	84	7.1	645	0.59	82	1.4	540	0.12	68	2KJ3604 - ■ ■ ■ A 0 ■ - 0 ■ V1
63.64	11.0	775	1.00	85	7.9	830	0.83	83	1.6	695	0.17	69	2KJ3604 - ■ ■ ■ A 0 ■ - 0 ■ U1
56.25	12.4	750	1.10	86	8.9	810	0.90	84	1.8	675	0.18	70	2KJ3604 - ■ ■ ■ A 0 ■ - 0 ■ T1
51.14	13.7	715	1.20	86	9.8	785	0.95	85	2.0	750	0.22	71	2KJ3604 - ■ ■ ■ A 0 ■ - 0 ■ S1
44.79	15.6	680	1.30	87	11.2	750	1.00	86	2.2	760	0.24	72	2KJ3604 - ■ ■ ■ A 0 ■ - 0 ■ R1
41.35	16.9	660	1.30	87	12.1	730	1.10	86	2.4	765	0.27	72	2KJ3604 - ■ ■ ■ A 0 ■ - 0 ■ Q1
36.61	19.1	630	1.50	87	13.7	700	1.20	87	2.7	770	0.30	73	2KJ3604 - ■ ■ ■ A 0 ■ - 0 ■ P1
30.00	23	560	1.50	90	16.7	555	1.10	89	3.3	480	0.22	77	2KJ3604 - ■ ■ ■ A 0 ■ - 0 ■ N1
26.28	27	550	1.70	90	19	545	1.20	90	3.8	480	0.24	78	2KJ3604 - ■ ■ ■ A 0 ■ - 0 ■ M1
24.26	29	545	1.80	90	21	540	1.30	90	4.1	475	0.26	79	2KJ3604 - ■ ■ ■ A 0 ■ - 0 ■ L1
21.48	33	540	2.10	91	23	540	1.40	90	4.7	475	0.30	80	2KJ3604 - ■ ■ ■ A 0 ■ - 0 ■ K1
17.88	39	545	2.50	91	28	545	1.80	91	5.6	490	0.35	82	2KJ3604 - ■ ■ ■ A 0 ■ - 0 ■ J1
15.88	44	365	1.80	92	31	360	1.30	91	6.3	330	0.26	83	2KJ3604 - ■ ■ ■ A 0 ■ - 0 ■ H1
14.06	50	360	2.10	92	36	355	1.50	92	7.1	330	0.29	84	2KJ3604 - ■ ■ ■ A 0 ■ - 0 ■ G1
11.70	60	365	2.50	92	43	365	1.80	92	8.5	340	0.36	85	2KJ3604 - ■ ■ ■ A 0 ■ - 0 ■ F1
11.01	64	365	2.70	92	45	365	1.90	92	9.1	340	0.38	86	2KJ3604 - ■ ■ ■ A 0 ■ - 0 ■ E1
9.87	71	365	3.00	92	51	365	2.10	92	10.1	345	0.43	86	2KJ3604 - ■ ■ ■ A 0 ■ - 0 ■ D1
8.40	83	370	3.50	92	60	370	2.50	92	11.9	350	0.50	87	2KJ3604 - ■ ■ ■ A 0 ■ - 0 ■ C1
7.20	97	365	4.10	92	69	365	2.90	92	13.9	350	0.59	88	2KJ3604 - ■ ■ ■ A 0 ■ - 0 ■ B1
6.20	113	365	4.70	92	81	365	3.40	92	16.1	355	0.67	89	2KJ3604 - ■ ■ ■ A 0 ■ - 0 ■ A1

SIMOGEAR Gearboxes

Helical worm gearboxes

Efficiencies

Selection and ordering data (continued)

i	$n_{mot} = 2\,800\text{ rpm}$				$n_{mot} = 1\,400\text{ rpm}$				$n_{mot} = 900\text{ rpm}$				Article No.
	n_2 rpm	T_{2N} Nm	P_{mot} kW	η %	n_2 rpm	T_{2N} Nm	P_{mot} kW	η %	n_2 rpm	T_{2N} Nm	P_{mot} kW	η %	
C.89													
363.00	7.7	1 180	1.30	73	3.9	1 460	0.83	72	2.5	1 430	0.55	68	2KJ3606 - ■ ■ A 0 ■ - 0 ■ N2
329.73	8.5	1 180	1.40	73	4.2	1 460	0.89	72	2.7	1 440	0.59	69	2KJ3606 - ■ ■ A 0 ■ - 0 ■ M2
295.75	9.5	1 170	1.60	73	4.7	1 460	0.99	73	3.0	1 460	0.66	70	2KJ3606 - ■ ■ A 0 ■ - 0 ■ L2
265.91	10.5	1 170	1.80	73	5.3	1 460	1.10	73	3.4	1 470	0.74	71	2KJ3606 - ■ ■ A 0 ■ - 0 ■ K2
240.50	11.6	1 160	1.90	73	5.8	1 450	1.20	73	3.7	1 480	0.80	72	2KJ3606 - ■ ■ A 0 ■ - 0 ■ J2
222.00	12.6	1 120	2.00	73	6.3	1 410	1.30	73	4.1	1 490	0.89	72	2KJ3606 - ■ ■ A 0 ■ - 0 ■ H2
203.36	13.8	1 090	2.20	73	6.9	1 370	1.40	73	4.4	1 500	0.95	73	2KJ3606 - ■ ■ A 0 ■ - 0 ■ G2
170.62	16.4	1 030	2.40	73	8.2	1 300	1.50	73	5.3	1 490	1.10	73	2KJ3606 - ■ ■ A 0 ■ - 0 ■ F2
160.59	17.4	1 010	2.50	73	8.7	1 270	1.60	73	5.6	1 460	1.20	74	2KJ3606 - ■ ■ A 0 ■ - 0 ■ E2
147.33	19	980	2.70	73	9.5	1 230	1.70	74	6.1	1 430	1.20	74	2KJ3606 - ■ ■ A 0 ■ - 0 ■ D2
128.70	22	915	2.90	73	10.9	1 150	1.80	73	7.0	1 340	1.30	74	2KJ3606 - ■ ■ A 0 ■ - 0 ■ C2
115.23	24	875	3.00	73	12.1	1 100	1.90	74	7.8	1 280	1.40	74	2KJ3606 - ■ ■ A 0 ■ - 0 ■ B2
100.75	28	830	3.30	73	13.9	1 040	2.10	74	8.9	1 210	1.50	74	2KJ3606 - ■ ■ A 0 ■ - 0 ■ A2
86.48	32	780	3.60	73	16.2	980	2.30	73	10.4	1 140	1.70	74	2KJ3606 - ■ ■ A 0 ■ - 0 ■ X1
76.44	37	740	4.00	73	18.3	935	2.40	73	11.8	1 080	1.80	74	2KJ3606 - ■ ■ A 0 ■ - 0 ■ W1
65.00	43	695	4.30	73	22	875	2.80	73	13.8	1 010	2.00	74	2KJ3606 - ■ ■ A 0 ■ - 0 ■ V1
55.61	50	1 150	6.70	90	25	1 450	4.20	91	16.2	1 550	2.90	90	2KJ3606 - ■ ■ A 0 ■ - 0 ■ U1
50.00	56	1 130	7.40	90	28	1 430	4.60	90	18.0	1 560	3.30	90	2KJ3606 - ■ ■ A 0 ■ - 0 ■ T1
45.22	62	1 100	7.90	90	31	1 380	5.00	91	19.9	1 560	3.60	90	2KJ3606 - ■ ■ A 0 ■ - 0 ■ S1
41.74	67	1 070	8.30	90	34	1 350	5.30	91	22	1 560	4.00	91	2KJ3606 - ■ ■ A 0 ■ - 0 ■ R1
38.24	73	1 040	8.80	90	37	1 310	5.60	91	24	1 520	4.20	91	2KJ3606 - ■ ■ A 0 ■ - 0 ■ Q1
32.08	87	985	10*	90	44	1 240	6.30	91	28	1 440	4.70	91	2KJ3606 - ■ ■ A 0 ■ - 0 ■ P1
30.20	93	950	10.3*	90	46	1 200	6.40	91	30	1 390	4.80	91	2KJ3606 - ■ ■ A 0 ■ - 0 ■ N1
27.70	101	920	10.8*	90	51	1 160	6.90	91	32	1 340	5.00	91	2KJ3606 - ■ ■ A 0 ■ - 0 ■ M1
25.03	112	1 080	13.7*	93	56	1 090	6.90	93	36	1 090	4.50	93	2KJ3606 - ■ ■ A 0 ■ - 0 ■ L1
21.00	133	1 000	15.1*	93	67	1 080	8.20	93	43	1 070	5.20	93	2KJ3606 - ■ ■ A 0 ■ - 0 ■ K1
19.76	142	980	15.8*	93	71	1 120	9.00	93	46	1 120	5.80	93	2KJ3606 - ■ ■ A 0 ■ - 0 ■ J1
18.13	154	950	16.6*	93	77	1 120	9.7*	93	50	1 120	6.30	93	2KJ3606 - ■ ■ A 0 ■ - 0 ■ H1
15.84	177	865	17.3*	93	88	1 140	11.3*	93	57	1 140	7.30	93	2KJ3606 - ■ ■ A 0 ■ - 0 ■ G1
14.18	197	770	17.3*	92	99	1 090	12.2*	93	63	1 150	8.20	93	2KJ3606 - ■ ■ A 0 ■ - 0 ■ F1
12.40	226	675	17.3*	93	113	1 040	13.3*	93	73	1 140	9.5*	93	2KJ3606 - ■ ■ A 0 ■ - 0 ■ E1
10.64	263	580	17.3*	92	132	985	14.7*	93	85	1 140	10.9*	93	2KJ3606 - ■ ■ A 0 ■ - 0 ■ D1
9.41	298	510	17.4*	92	149	940	15.9*	93	96	1 090	11.8*	93	2KJ3606 - ■ ■ A 0 ■ - 0 ■ C1
8.00	350	435	17.4*	92	175	870	17.3*	93	112	1 030	13.1*	93	2KJ3606 - ■ ■ A 0 ■ - 0 ■ B1
6.86	408	370	17.4*	92	204	745	17.3*	93	131	980	14.5*	93	2KJ3606 - ■ ■ A 0 ■ - 0 ■ A1

* $P_{mot\ max} = 9.2\text{ kW}$

Selection and ordering data (continued)

i	$n_{\text{mot}} = 700 \text{ rpm}$				$n_{\text{mot}} = 500 \text{ rpm}$				$n_{\text{mot}} = 100 \text{ rpm}$				Article No.
	n_2 rpm	T_{2N} Nm	P_{mot} kW	η %	n_2 rpm	T_{2N} Nm	P_{mot} kW	η %	n_2 rpm	T_{2N} Nm	P_{mot} kW	η %	
C.89													
363.00	1.9	1 360	0.42	64	1.4	1 260	0.31	60	0.28	955	0.06	45	2KJ3606 - ■ ■ A 0 ■ - 0 ■ N2
329.73	2.1	1 380	0.46	66	1.5	1 280	0.33	61	0.30	960	0.07	45	2KJ3606 - ■ ■ A 0 ■ - 0 ■ M2
295.75	2.4	1 400	0.53	67	1.7	1 310	0.37	62	0.34	965	0.08	45	2KJ3606 - ■ ■ A 0 ■ - 0 ■ L2
265.91	2.6	1 420	0.57	68	1.9	1 330	0.42	64	0.38	975	0.08	46	2KJ3606 - ■ ■ A 0 ■ - 0 ■ K2
240.50	2.9	1 440	0.63	70	2.1	1 360	0.46	66	0.42	985	0.09	47	2KJ3606 - ■ ■ A 0 ■ - 0 ■ J2
222.00	3.2	1 450	0.69	70	2.3	1 380	0.50	67	0.45	995	0.10	47	2KJ3606 - ■ ■ A 0 ■ - 0 ■ H2
203.36	3.4	1 470	0.74	71	2.5	1 400	0.54	68	0.49	1 000	0.11	48	2KJ3606 - ■ ■ A 0 ■ - 0 ■ G2
170.62	4.1	1 490	0.89	72	2.9	1 440	0.63	70	0.59	1 030	0.13	50	2KJ3606 - ■ ■ A 0 ■ - 0 ■ F2
160.59	4.4	1 490	0.95	73	3.1	1 450	0.67	71	0.62	1 040	0.14	50	2KJ3606 - ■ ■ A 0 ■ - 0 ■ E2
147.33	4.8	1 500	1.00	73	3.4	1 460	0.73	71	0.68	1 060	0.15	51	2KJ3606 - ■ ■ A 0 ■ - 0 ■ D2
128.70	5.4	1 450	1.10	74	3.9	1 480	0.84	72	0.78	1 090	0.17	53	2KJ3606 - ■ ■ A 0 ■ - 0 ■ C2
115.23	6.1	1 390	1.20	74	4.3	1 490	0.92	73	0.87	1 110	0.19	54	2KJ3606 - ■ ■ A 0 ■ - 0 ■ B2
100.75	6.9	1 310	1.30	74	5.0	1 460	1.00	74	0.99	1 150	0.21	56	2KJ3606 - ■ ■ A 0 ■ - 0 ■ A2
86.48	8.1	1 230	1.40	74	5.8	1 380	1.10	74	1.2	1 190	0.26	58	2KJ3606 - ■ ■ A 0 ■ - 0 ■ X1
76.44	9.2	1 170	1.50	74	6.5	1 310	1.20	74	1.3	1 220	0.28	60	2KJ3606 - ■ ■ A 0 ■ - 0 ■ W1
65.00	10.8	1 100	1.70	74	7.7	1 230	1.30	74	1.5	1 270	0.32	62	2KJ3606 - ■ ■ A 0 ■ - 0 ■ V1
55.61	12.6	1 540	2.30	90	9.0	1 510	1.60	88	1.8	1 290	0.33	75	2KJ3606 - ■ ■ A 0 ■ - 0 ■ U1
50.00	14.0	1 540	2.50	90	10.0	1 530	1.80	88	2.0	1 430	0.40	75	2KJ3606 - ■ ■ A 0 ■ - 0 ■ T1
45.22	15.5	1 550	2.80	90	11.1	1 530	2.00	89	2.2	1 430	0.43	76	2KJ3606 - ■ ■ A 0 ■ - 0 ■ S1
41.74	16.8	1 550	3.00	90	12.0	1 540	2.20	89	2.4	1 450	0.48	77	2KJ3606 - ■ ■ A 0 ■ - 0 ■ R1
38.24	18.3	1 560	3.30	90	13.1	1 540	2.40	90	2.6	1 450	0.51	77	2KJ3606 - ■ ■ A 0 ■ - 0 ■ Q1
32.08	22	1 560	4.00	91	15.6	1 550	2.80	90	3.1	1 390	0.57	79	2KJ3606 - ■ ■ A 0 ■ - 0 ■ P1
30.20	23	1 510	4.00	91	16.6	1 550	3.00	90	3.3	1 460	0.64	79	2KJ3606 - ■ ■ A 0 ■ - 0 ■ N1
27.70	25	1 460	4.20	91	18.1	1 560	3.30	91	3.6	1 470	0.69	80	2KJ3606 - ■ ■ A 0 ■ - 0 ■ M1
25.03	28	1 090	3.50	93	20	1 080	2.50	92	4.0	990	0.50	84	2KJ3606 - ■ ■ A 0 ■ - 0 ■ L1
21.00	33	1 070	4.00	93	24	1 070	2.90	92	4.8	985	0.59	85	2KJ3606 - ■ ■ A 0 ■ - 0 ■ K1
19.76	35	1 120	4.50	93	25	1 120	3.20	92	5.1	1 030	0.65	85	2KJ3606 - ■ ■ A 0 ■ - 0 ■ J1
18.13	39	1 110	4.90	93	28	1 110	3.50	92	5.5	1 030	0.70	85	2KJ3606 - ■ ■ A 0 ■ - 0 ■ H1
15.84	44	1 140	5.70	93	32	1 130	4.10	93	6.3	1 050	0.81	86	2KJ3606 - ■ ■ A 0 ■ - 0 ■ G1
14.18	49	1 150	6.40	93	35	1 140	4.50	93	7.1	1 070	0.92	87	2KJ3606 - ■ ■ A 0 ■ - 0 ■ F1
12.40	56	1 140	7.30	93	40	1 140	5.20	93	8.1	1 080	1.00	88	2KJ3606 - ■ ■ A 0 ■ - 0 ■ E1
10.64	66	1 150	8.50	93	47	1 140	6.10	93	9.4	1 090	1.20	88	2KJ3606 - ■ ■ A 0 ■ - 0 ■ D1
9.41	74	1 120	9.4*	93	53	1 120	6.70	93	10.6	1 070	1.30	89	2KJ3606 - ■ ■ A 0 ■ - 0 ■ C1
8.00	88	1 120	11.2*	93	62	1 130	7.90	93	12.5	1 090	1.60	90	2KJ3606 - ■ ■ A 0 ■ - 0 ■ B1
6.86	102	1 060	12.3*	93	73	1 110	9.20	93	14.6	1 090	1.80	91	2KJ3606 - ■ ■ A 0 ■ - 0 ■ A1

* $P_{\text{mot max}} = 9.2 \text{ kW}$

SIMOGEAR Gearboxes

Helical worm gearboxes

Dimensions

Dimensional drawing overview

Information about dimensional drawings can be found in the Chapter [Introduction on page 1/20](#).

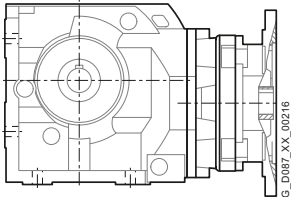
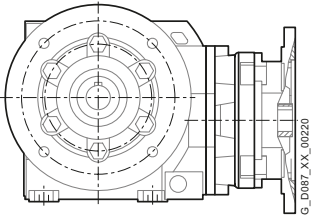
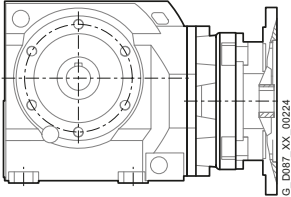
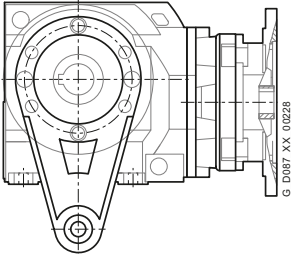
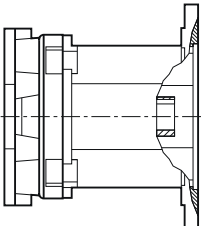
Version	Size	Dimensional drawing on page
Helical worm gearbox with adapter K4		
<i>Foot-mounted design</i>		
	C..29	6/21
	C..39	6/25
	C..49	6/29
	C..69	6/33
	C..89	6/37
<i>Flange-mounted design</i>		
	C.F.29	6/22
	C.F.39	6/26
	C.F.49	6/30
	C.F.69	6/34
	C.F.89	6/38
<i>Housing flange design</i>		
	C.Z.29	6/23
	C.Z.39	6/27
	C.Z.49	6/31
	C.Z.69	6/35
	C.Z.89	6/39
<i>Shaft-mounted design</i>		
	CAD.29	6/24
	CAD.39	6/28
	CAD.49	6/32
	CAD.69	6/36
	CAD.89	6/40
Helical worm gearbox with adapter K2		
	C..29 ... C..89	6/41

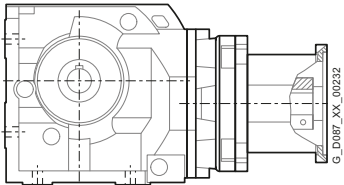
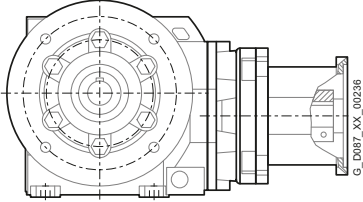
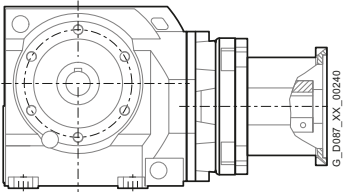
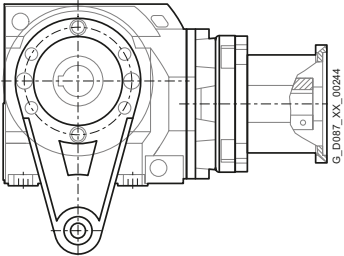
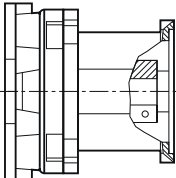

Dimensional drawing overview (continued)

Version	Size	Dimensional drawing on page
Helical worm gearbox with adapter KQ		
<i>Foot-mounted design</i>		
	C..29	6/42
	C..39	6/46
	C..49	6/50
	C..69	6/54
	C..89	6/58
<i>Flange-mounted design</i>		
	C.F.29	6/43
	C.F.39	6/47
	C.F.49	6/51
	C.F.69	6/55
	C.F.89	6/59
<i>Housing flange design</i>		
	C.Z.29	6/44
	C.Z.39	6/48
	C.Z.49	6/52
	C.Z.69	6/56
	C.Z.89	6/60
<i>Shaft-mounted design</i>		
	CAD.29	6/45
	CAD.39	6/49
	CAD.49	6/53
	CAD.69	6/57
	CAD.89	6/61
Helical worm gearbox with adapter KQS		
	C..29 ... C..89	6/62

SIMOGEAR Gearboxes

Helical worm gearboxes

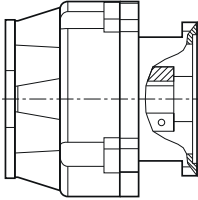
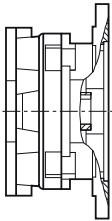
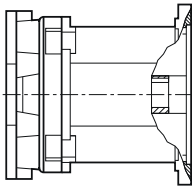
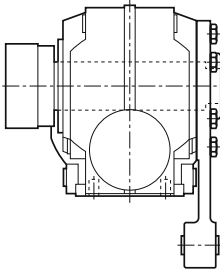
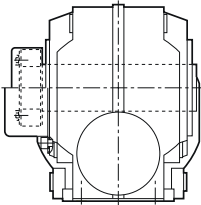
Dimensions**Dimensional drawing overview** (continued)

Version	Size	Dimensional drawing on page
Helical worm gearbox with adapter K8	C..29 ... C..89	6/63
		
Helical worm gearbox with adapter K5	C..29 ... C..89	6/64
		
Helical worm gearbox with adapter K3	C..29 ... C..89	6/65
		
Additional versions and options		
	SIMOLOC assembly system	6/66
	Protection cover for hollow shaft	6/68
	Inner contour of the flange design	6/69

SIMOGEAR Gearboxes

Helical worm gearbox with adapter K4

Dimensions

C..29 gearbox in a foot-mounted design

C030K4, CA030K4, CAS030K4

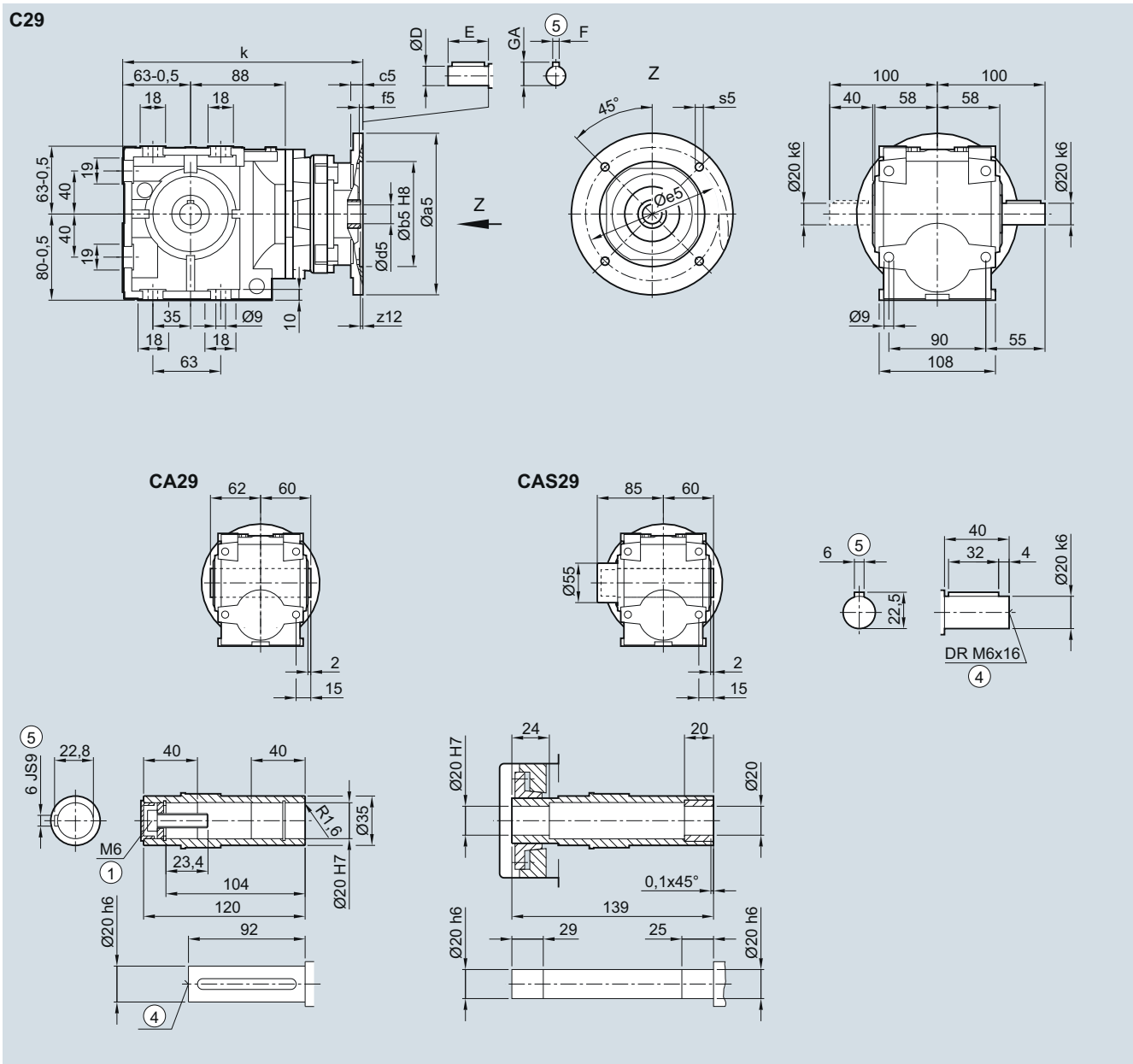

Adapter	a5	b5	c5	f5	e5	s5	z12	d5/D	E	F	GA	k
63	140	95	12	4.5	115	M8	2.5	11	23	4	12.5	228.5
71	160	110	12	4.5	130	M8	2.5	14	30	5	16.0	228.5
80	200	130	15	4.5	165	M10	4.0	19	40	6	12.5	256.5
90	200	130	15	4.5	165	M10	4.0	24	50	8	27.0	256.5

① ISO 4014

④ DIN 332

⑤ Feather key/keyway DIN 6885

SIMOGEAR Gearboxes

Helical worm gearbox with adapter K4

Dimensions

C.F.29 gearbox in a flange-mounted design

CF030K4, CAF030K4, CAFS030K4

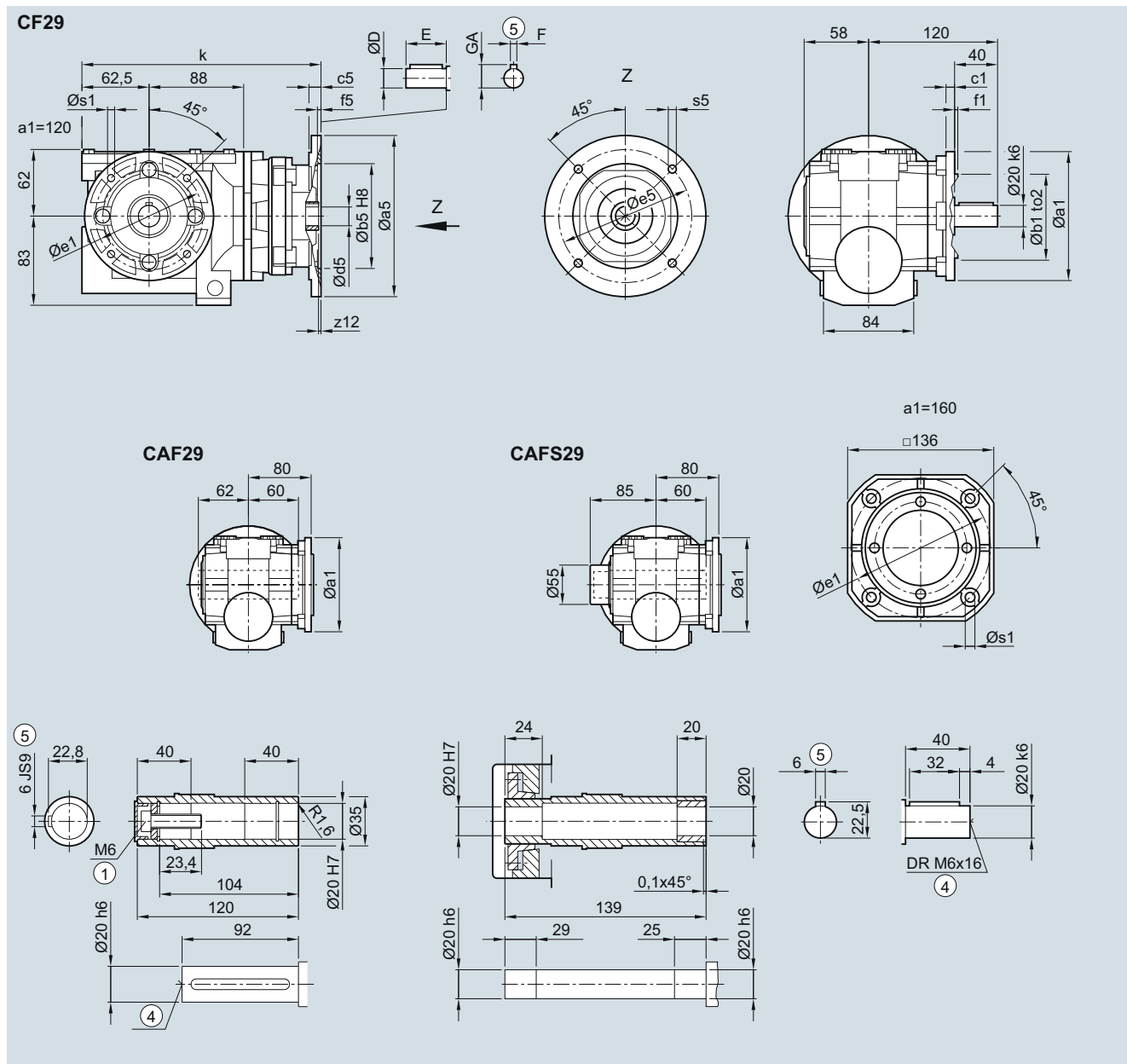

Flange	a1	b1	to2	c1	e1	f1	s1					
	120	80	j6	8	100	3.0	6.6					
	160	110	j6	9	130	3.5	9.0					
Adapter	a5	b5	c5	f5	e5	s5	z12	d5/D	E	F	GA	k
63	140	95	12	4.5	115	M8	2.5	11	23	4	12.5	228.0
71	160	110	12	4.5	130	M8	2.5	14	30	5	16.0	228.0
80	200	130	15	4.5	165	M10	4.0	19	40	6	12.5	256.0
90	200	130	15	4.5	165	M10	4.0	24	50	8	27.0	256.0

① ISO 4014

④ DIN 332

⑤ Feather key/keyway DIN 6885

C.Z.29 gearbox in a housing flange design

CZ030K4, CAZ030K4, CAZS030K4

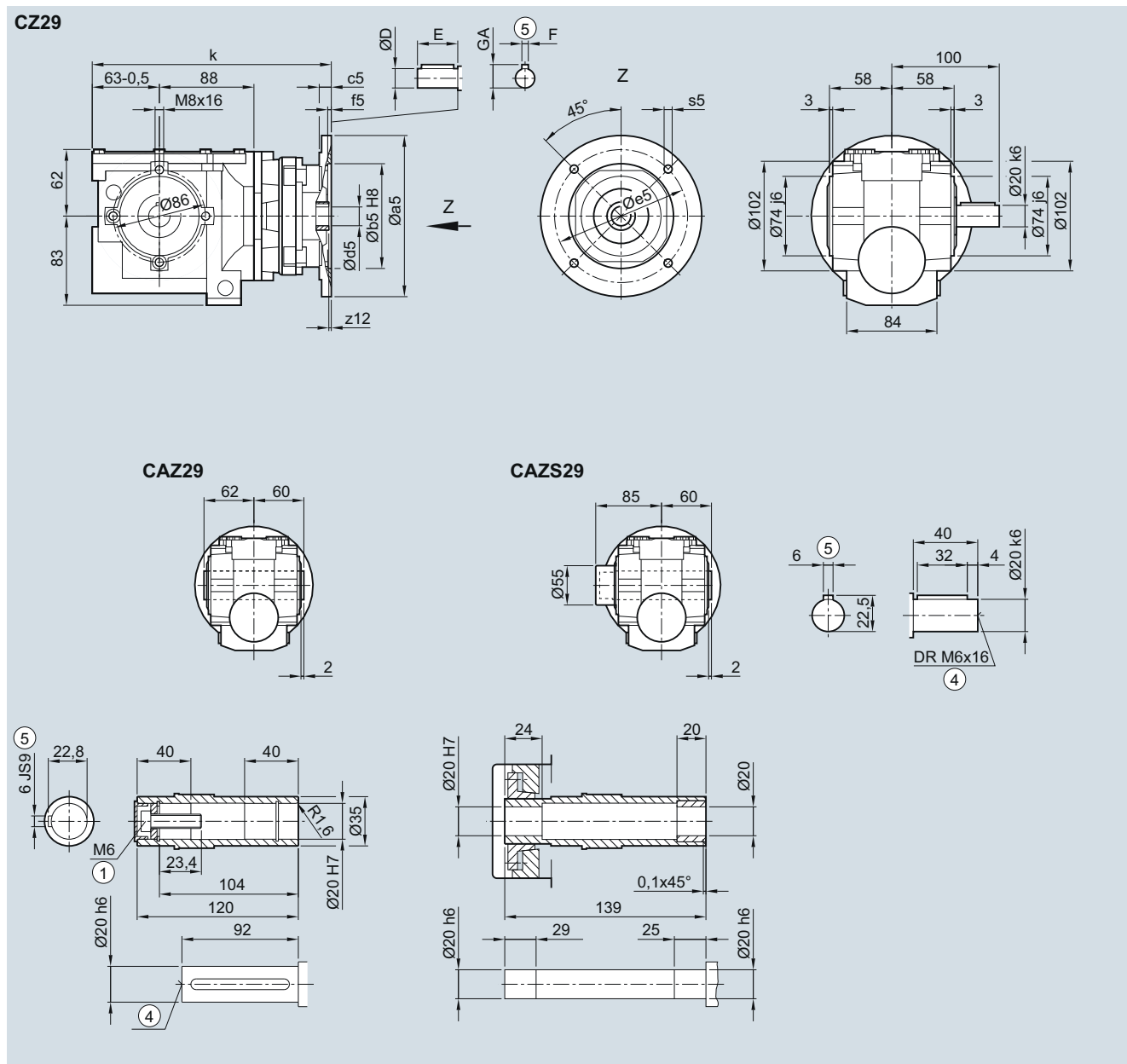

Adapter	a5	b5	c5	f5	e5	s5	z12	d5/D	E	F	GA	k
63	140	95	12	4.5	115	M8	2.5	11	23	4	12.5	228.0
71	160	110	12	4.5	130	M8	2.5	14	30	5	16.0	228.0
80	200	130	15	4.5	165	M10	4.0	19	40	6	12.5	256.0
90	200	130	15	4.5	165	M10	4.0	24	50	8	27.0	256.0

① ISO 4014

④ DIN 332

⑤ Feather key/keyway DIN 6885

SIMOGEAR Gearboxes

Helical worm gearbox with adapter K4

Dimensions

CAD.29 gearbox in a shaft-mounted design

CAD030K4, CADS030K4

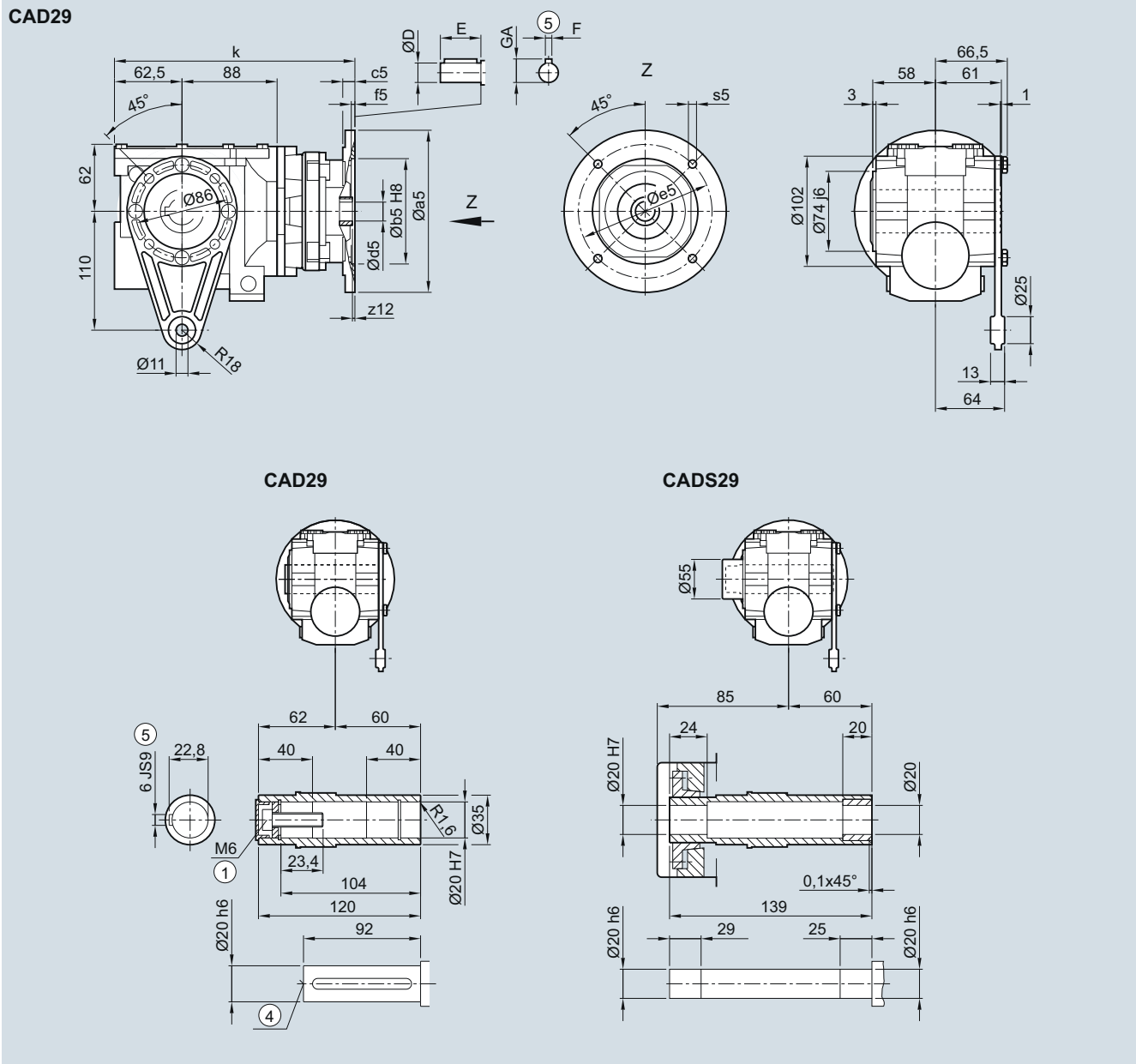

Adapter	a5	b5	c5	f5	e5	s5	z12	d5/D	E	F	GA	k
63	140	95	12	4.5	115	M8	2.5	11	23	4	12.5	228.0
71	160	110	12	4.5	130	M8	2.5	14	30	5	16.0	228.0
80	200	130	15	4.5	165	M10	4.0	19	40	6	12.5	256.0
90	200	130	15	4.5	165	M10	4.0	24	50	8	27.0	256.0

① ISO 4014

④ DIN 332

⑤ Feather key/keyway DIN 6885

SIMOGEAR Gearboxes

Helical worm gearbox with adapter K4

Dimensions

C.F.39 gearbox in a flange-mounted design

CF030K4, CAF030K4, CAFS030K4

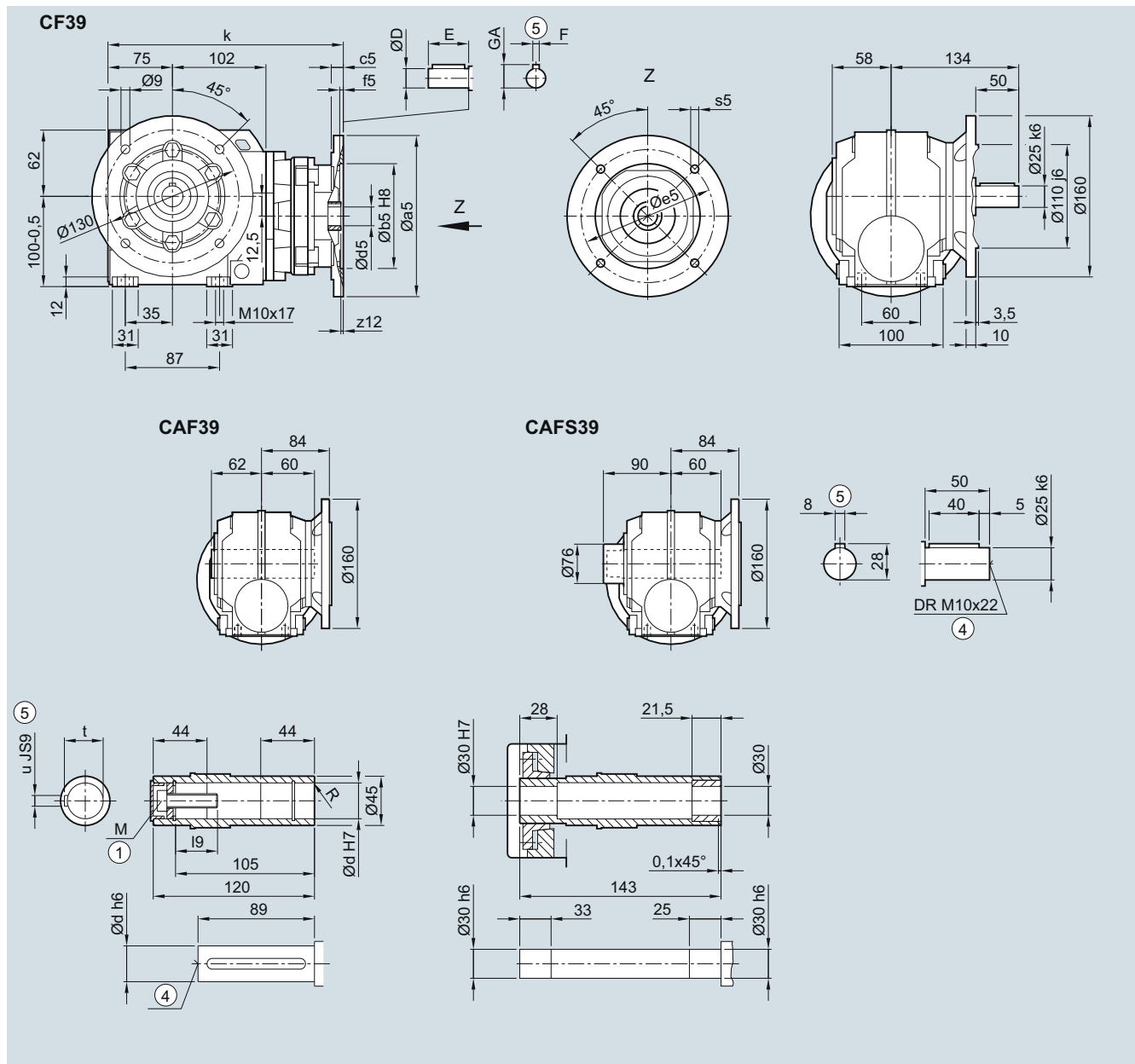

Shaft	d	I9	M	t	u
	25	32.6	M10	28.3	8
	30	32.6	M10	33.3	8

Adapter	a5	b5	c5	f5	e5	s5	z12	d5/D	E	F	GA	k
63	140	95	12	4.5	115	M8	2.5	11	23	4	12.5	254.5
71	160	110	12	4.5	130	M8	2.5	14	30	5	16.0	254.5
80	200	130	15	4.5	165	M10	4.0	19	40	6	12.5	282.5
90	200	130	15	4.5	165	M10	4.0	24	50	8	27.0	282.5
100	250	180	14	5.0	215	M12x21	7.5	28	60	8	31.0	337.0

① ISO 4014

④ DIN 332

⑤ Feather key/keyway DIN 6885

C.Z.39 gearbox in a housing flange design

CZ030K4, CAZ030K4, CAZS030K4

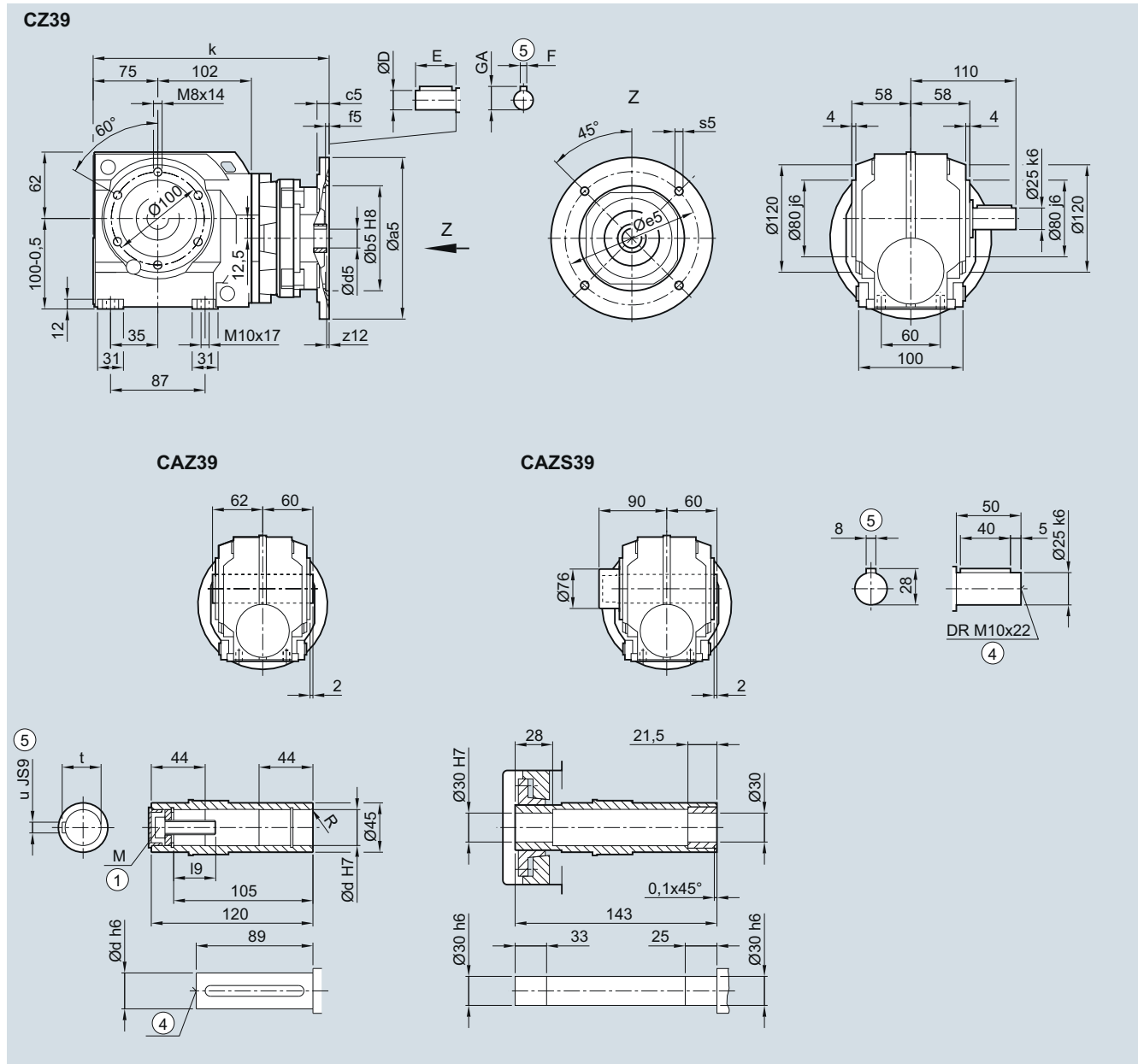

Shaft	d	l9	M	t	u							
	25	32.6	M10	28.3	8							
	30	32.6	M10	33.3	8							
Adapter	a5	b5	c5	f5	e5	s5	z12	d5/D	E	F	GA	k
63	140	95	12	4.5	115	M8	2.5	11	23	4	12.5	254.5
71	160	110	12	4.5	130	M8	2.5	14	30	5	16.0	254.5
80	200	130	15	4.5	165	M10	4.0	19	40	6	12.5	282.5
90	200	130	15	4.5	165	M10	4.0	24	50	8	27.0	282.5
100	250	180	14	5.0	215	M12x21	7.5	28	60	8	31.0	337.0

① ISO 4014

④ DIN 332

⑤ Feather key/keyway DIN 6885

SIMOGEAR Gearboxes

Helical worm gearbox with adapter K4

Dimensions

CAD.39 gearbox in a shaft-mounted design

CAD030K4, CADS030K4

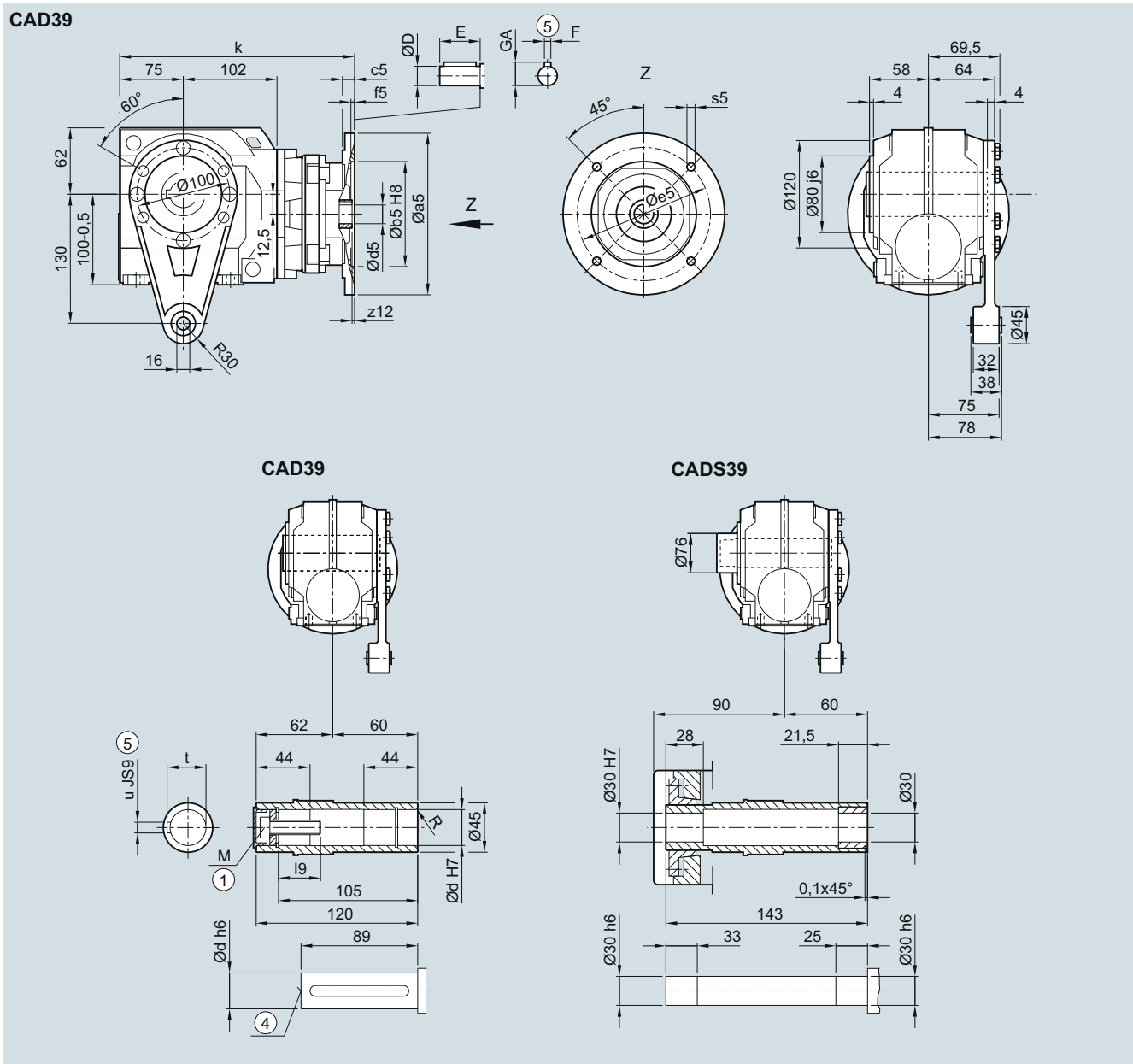

Shaft	d	l9	M	t	u							
	25	32.6	M10	28.3	8							
	30	32.6	M10	33.3	8							
Adapter	a5	b5	c5	f5	e5	s5	z12	d5/D	E	F	GA	k
63	140	95	12	4.5	115	M8	2.5	11	23	4	12.5	254.5
71	160	110	12	4.5	130	M8	2.5	14	30	5	16.0	254.5
80	200	130	15	4.5	165	M10	4.0	19	40	6	12.5	282.5
90	200	130	15	4.5	165	M10	4.0	24	50	8	27.0	282.5
100	250	180	14	5.0	215	M12x21	7.5	28	60	8	31.0	337.0

① ISO 4014

④ DIN 332

⑤ Feather key/keyway DIN 6885

C..49 gearbox in a foot-mounted design

C030K4, CA030K4, CAS030K4

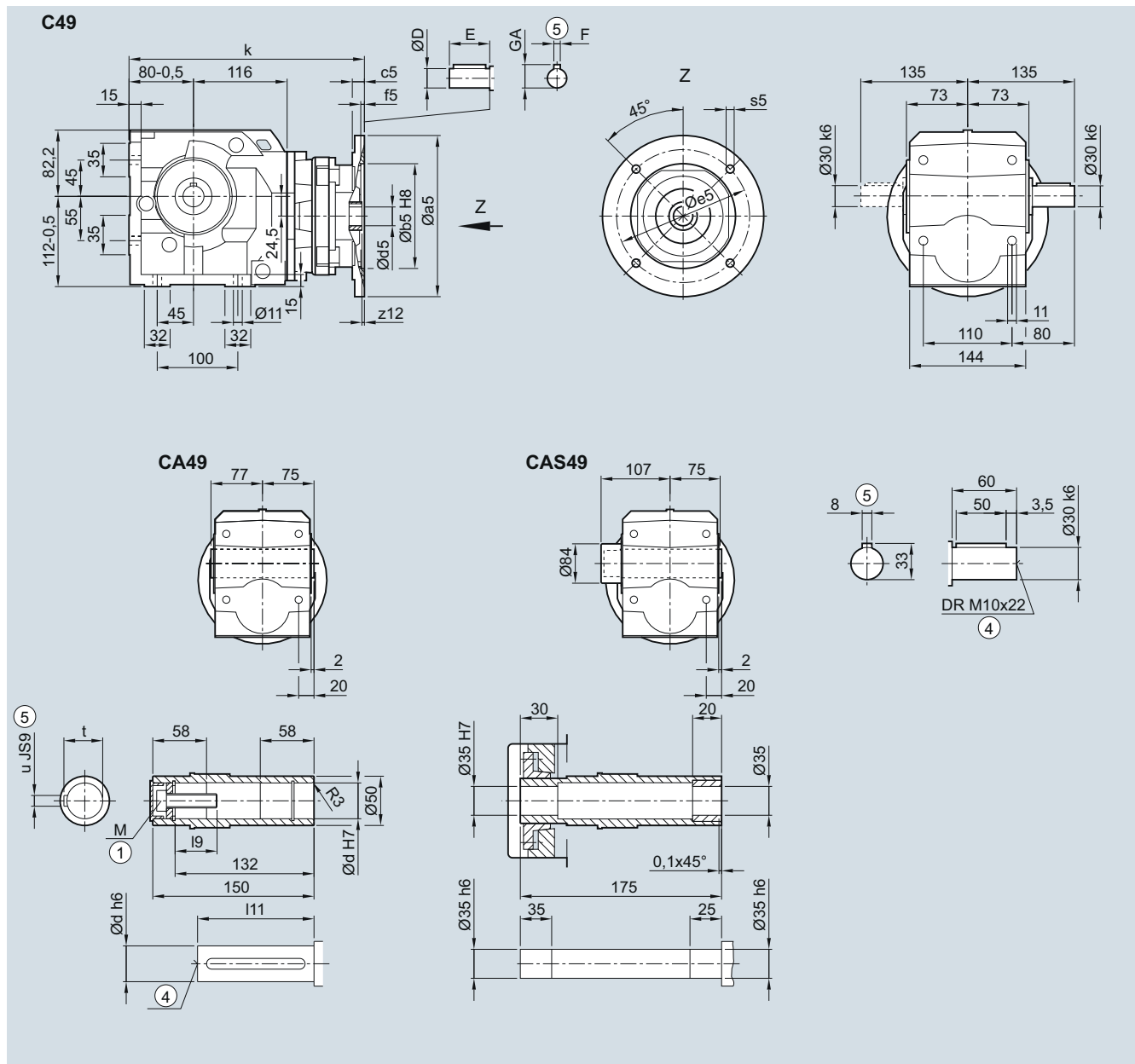

Shaft	d	l9	M	t	u
	30	32.6	M10	33.3	8
	35	42	M12	38.3	10

Adapter	a5	b5	c5	f5	e5	s5	z12	d5/D	E	F	GA	k
63	140	95	12	4.5	115	M8	2.5	11	23	4	12.5	264.0
71	160	110	12	4.5	130	M8	2.5	14	30	5	16.0	264.0
80	200	130	15	4.5	165	M10	4.0	19	40	6	12.5	292.0
90	200	130	15	4.5	165	M10	4.0	24	50	8	27.0	292.0
100	250	180	14	5.0	215	M12x21	7.5	28	60	8	31.0	346.5
112	250	180	14	5.0	215	M12x21	7.5	28	60	8	31.0	346.5

① ISO 4014

④ DIN 332

⑤ Feather key/keyway DIN 6885

SIMOGEAR Gearboxes

Helical worm gearbox with adapter K4

Dimensions

C.F.49 gearbox in a flange-mounted design

CF030K4, CAF030K4, CAFS030K4

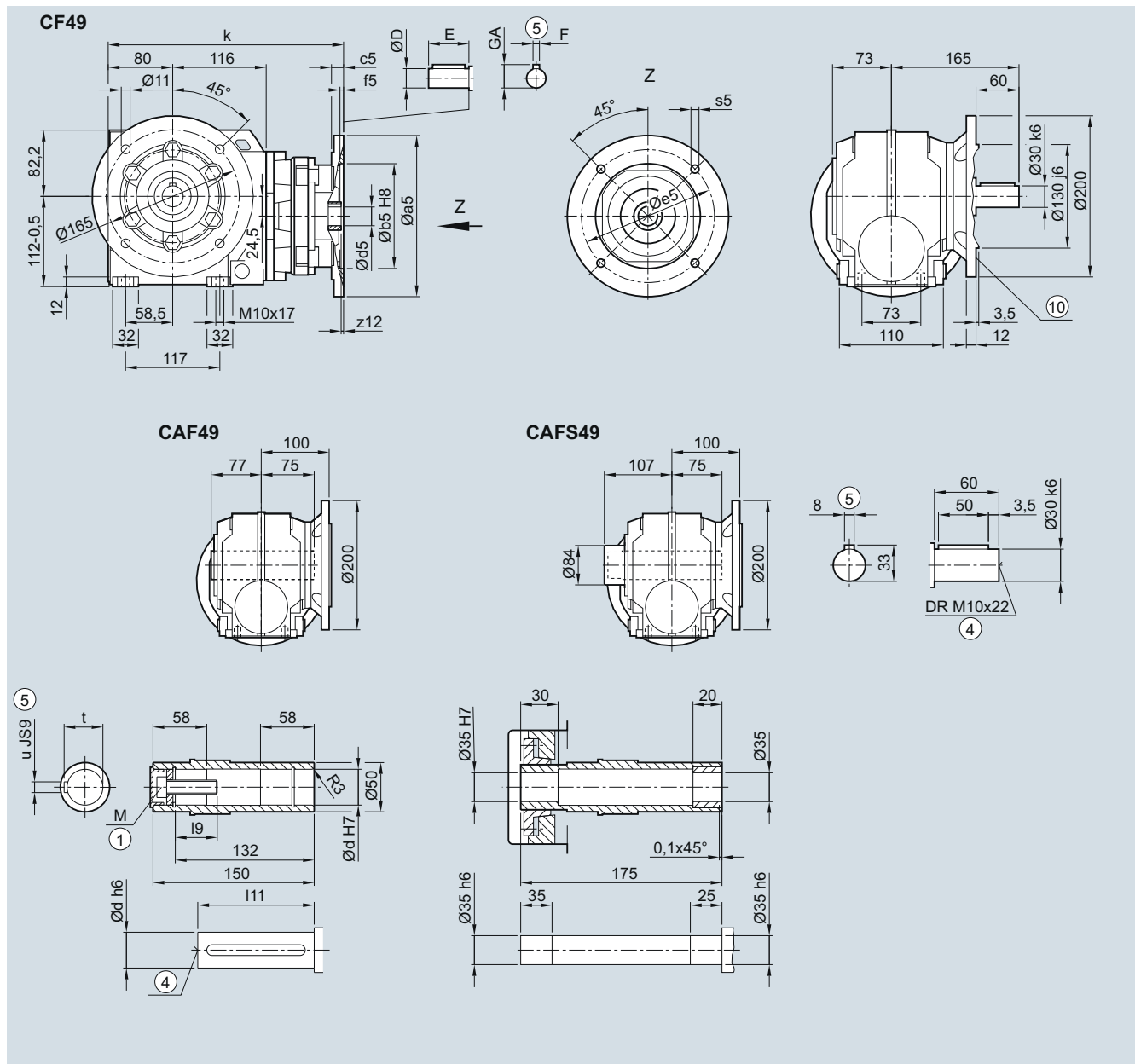

Shaft	d	I9	M	t	u
	30	32.6	M10	33.3	8
	35	42	M12	38.3	10

Adapter	a5	b5	c5	f5	e5	s5	z12	d5/D	E	F	GA	k
63	140	95	12	4.5	115	M8	2.5	11	23	4	12.5	264.0
71	160	110	12	4.5	130	M8	2.5	14	30	5	16.0	264.0
80	200	130	15	4.5	165	M10	4.0	19	40	6	12.5	292.0
90	200	130	15	4.5	165	M10	4.0	24	50	8	27.0	292.0
100	250	180	14	5.0	215	M12x21	7.5	28	60	8	31.0	346.5
112	250	180	14	5.0	215	M12x21	7.5	28	60	8	31.0	346.5

① ISO 4014

④ DIN 332

⑤ Feather key/keyway DIN 6885

SIMOGEAR Gearboxes

Helical worm gearbox with adapter K4

Dimensions

C.Z.49 gearbox in a housing flange design

CZ030K4, CAZ030K4, CAZS030K4

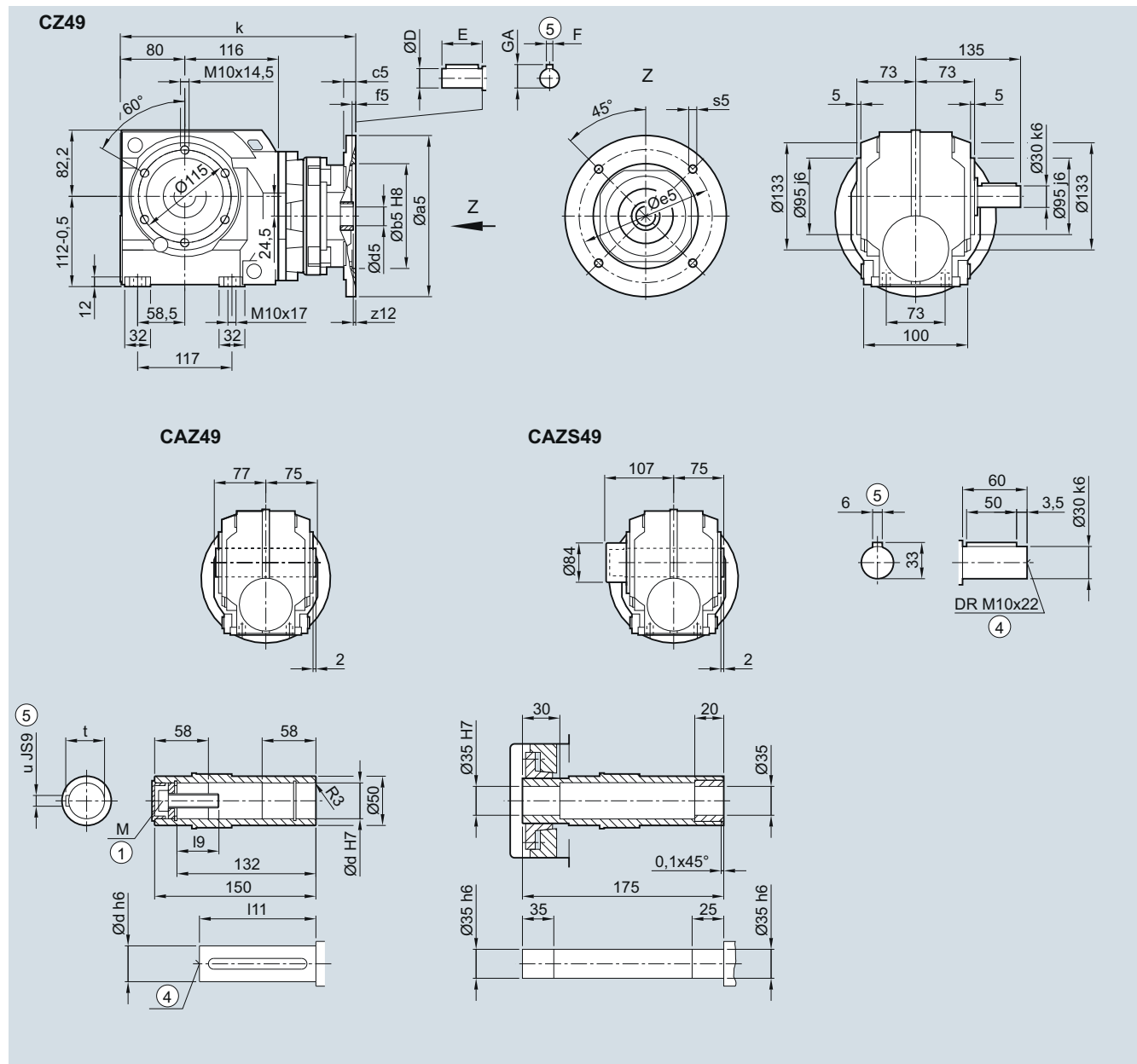

Shaft	d	l9	M	t	u								
	30	32.6	M10	33.3	8								
	35	42	M12	38.3	10								
Adapter	a5	b5	c5	f5	e5	s5	z12	d5/D	E	F	GA	k	
	63	140	95	12	4.5	115	M8	2.5	11	23	4	12.5	264.0
	71	160	110	12	4.5	130	M8	2.5	14	30	5	16.0	264.0
	80	200	130	15	4.5	165	M10	4.0	19	40	6	12.5	292.0
	90	200	130	15	4.5	165	M10	4.0	24	50	8	27.0	292.0
	100	250	180	14	5.0	215	M12x21	7.5	28	60	8	31.0	346.5
	112	250	180	14	5.0	215	M12x21	7.5	28	60	8	31.0	346.5

① ISO 4014

④ DIN 332

⑤ Feather key/keyway DIN 6885

SIMOGEAR Gearboxes

Helical worm gearbox with adapter K4

Dimensions

CAD.49 gearbox in a shaft-mounted design

CAD030K4, CADS030K4

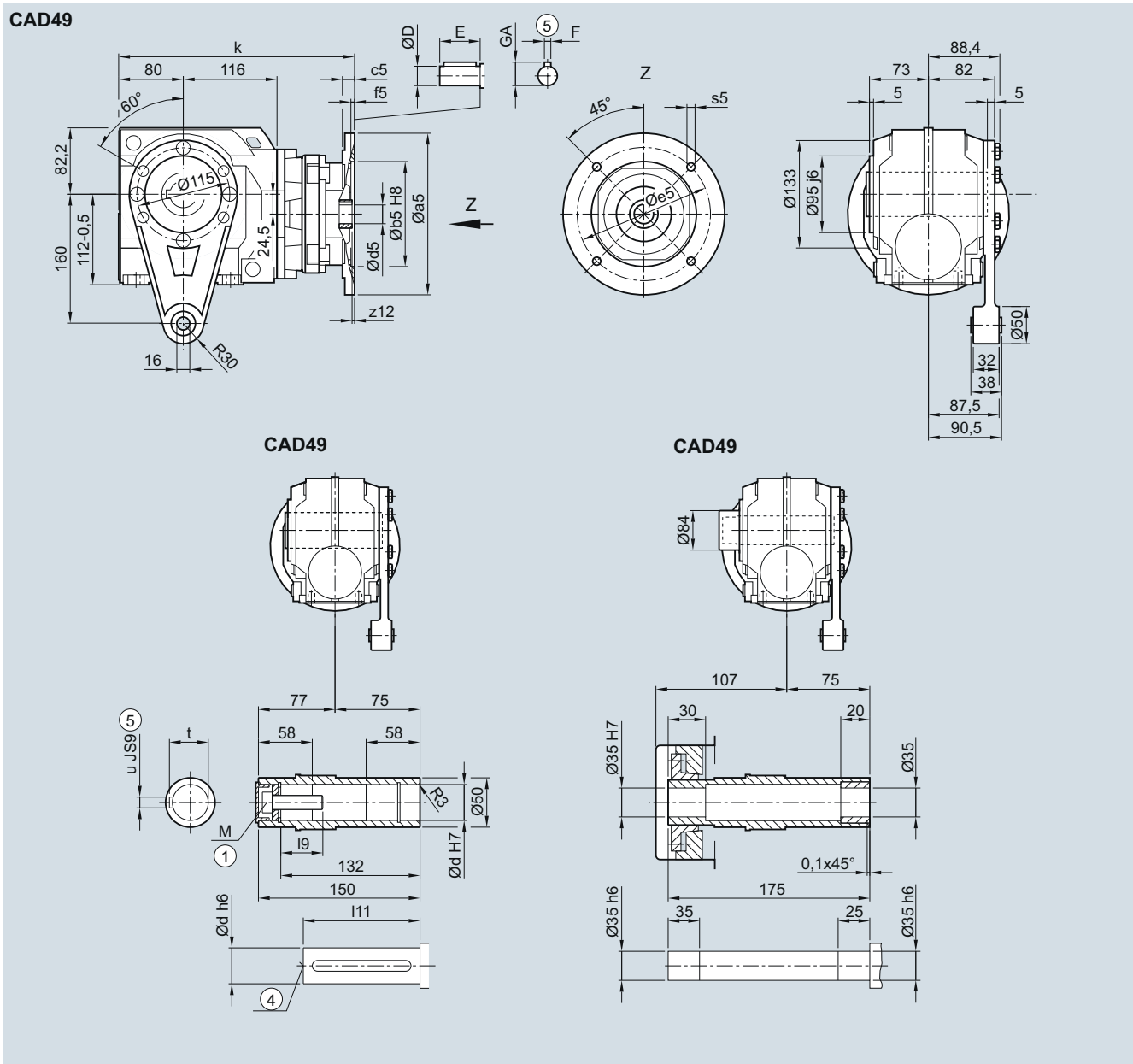

Shaft	d	l9	M	t	u							
	30	32.6	M10	33.3	8							
	35	42	M12	38.3	10							
Adapter	a5	b5	c5	f5	e5	s5	z12	d5/D	E	F	GA	k
63	140	95	12	4.5	115	M8	2.5	11	23	4	12.5	264.0
71	160	110	12	4.5	130	M8	2.5	14	30	5	16.0	264.0
80	200	130	15	4.5	165	M10	4.0	19	40	6	12.5	292.0
90	200	130	15	4.5	165	M10	4.0	24	50	8	27.0	292.0
100	250	180	14	5.0	215	M12x21	7.5	28	60	8	31.0	346.5
112	250	180	14	5.0	215	M12x21	7.5	28	60	8	31.0	346.5

① ISO 4014

④ DIN 332

⑤ Feather key/keyway DIN 6885

SIMOGEAR Gearboxes

Helical worm gearbox with adapter K4

Dimensions

C..69 gearbox in a foot-mounted design

C030K4, CA030K4, CAS030K4

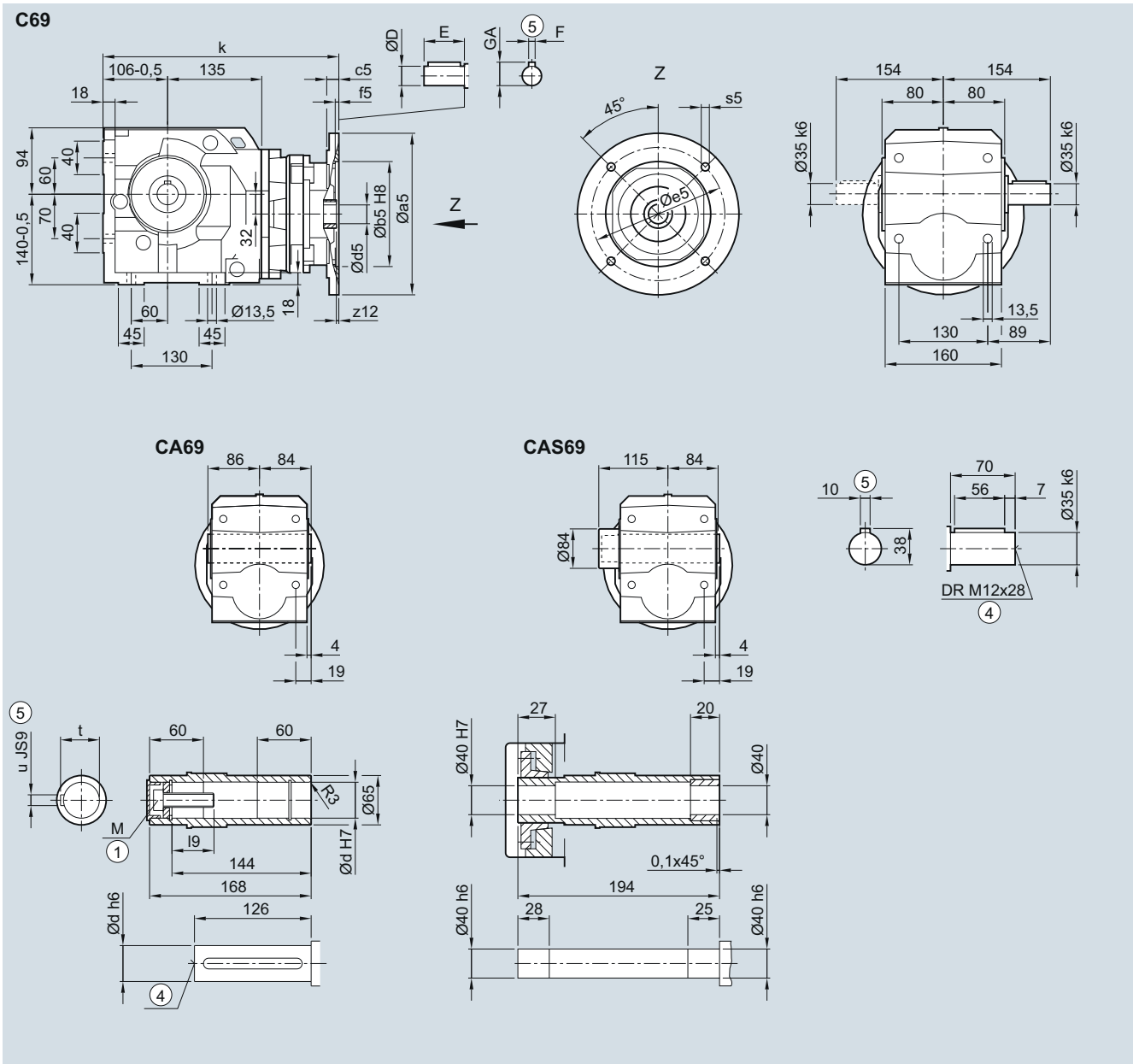

Shaft	d	l9	M	t	u
	40	47.75	M16	43.3	12
	45	48.75	M16	48.3	14

Adapter	a5	b5	c5	f5	e5	s5	z12	d5/D	E	F	GA	k
63	140	95	12	4.5	115	M8	2.5	11	23	4	12.5	309.0
71	160	110	12	4.5	130	M8	2.5	14	30	5	16.0	309.0
80	200	130	15	4.5	165	M10	4.0	19	40	6	12.5	337.0
90	200	130	15	4.5	165	M10	4.0	24	50	8	27.0	337.0
100	250	180	14	5.0	215	M12x21	7.5	28	60	8	31.0	391.5
112	250	180	14	5.0	215	M12x21	7.5	28	60	8	31.0	391.5
132	300	230	12	6.0	265	M12x20	3.0	38	80	10	41.0	409.0

① ISO 4014

④ DIN 332

⑤ Feather key/keyway DIN 6885

SIMOGEAR Gearboxes

Helical worm gearbox with adapter K4

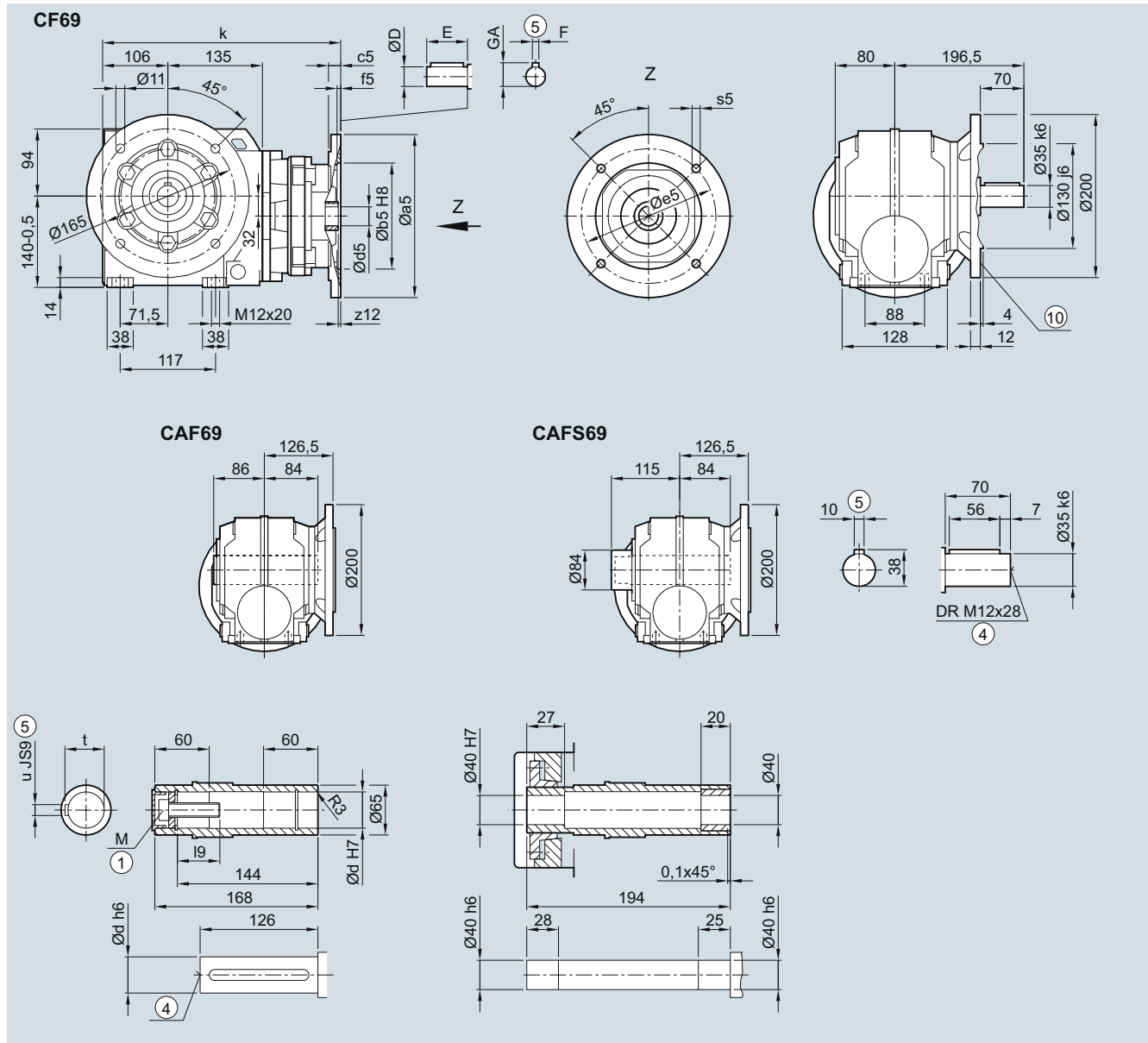
Dimensions**C.F.69 gearbox in a flange-mounted design****CF030K4, CAF030K4, CAFS030K4**

Shaft	d	l ₉	M	t	u
	40	47.75	M16	43.3	12
	45	48.75	M16	48.3	14

Adapter	a ₅	b ₅	c ₅	f ₅	e ₅	s ₅	z12	d ₅ /D	E	F	GA	k
63	140	95	12	4.5	115	M8	2.5	11	23	4	12.5	309.0
71	160	110	12	4.5	130	M8	2.5	14	30	5	16.0	309.0
80	200	130	15	4.5	165	M10	4.0	19	40	6	12.5	337.0
90	200	130	15	4.5	165	M10	4.0	24	50	8	27.0	337.0
100	250	180	14	5.0	215	M12x21	7.5	28	60	8	31.0	391.5
112	250	180	14	5.0	215	M12x21	7.5	28	60	8	31.0	391.5
132	300	230	12	6.0	265	M12x20	3.0	38	80	10	41.0	409.0

① ISO 4014

④ DIN 332

⑤ Feather key/keyway DIN 6885

SIMOGEAR Gearboxes

Helical worm gearbox with adapter K4

Dimensions

C.Z.69 gearbox in a housing flange design

CZ030K4, CAZ030K4, CAZS030K4

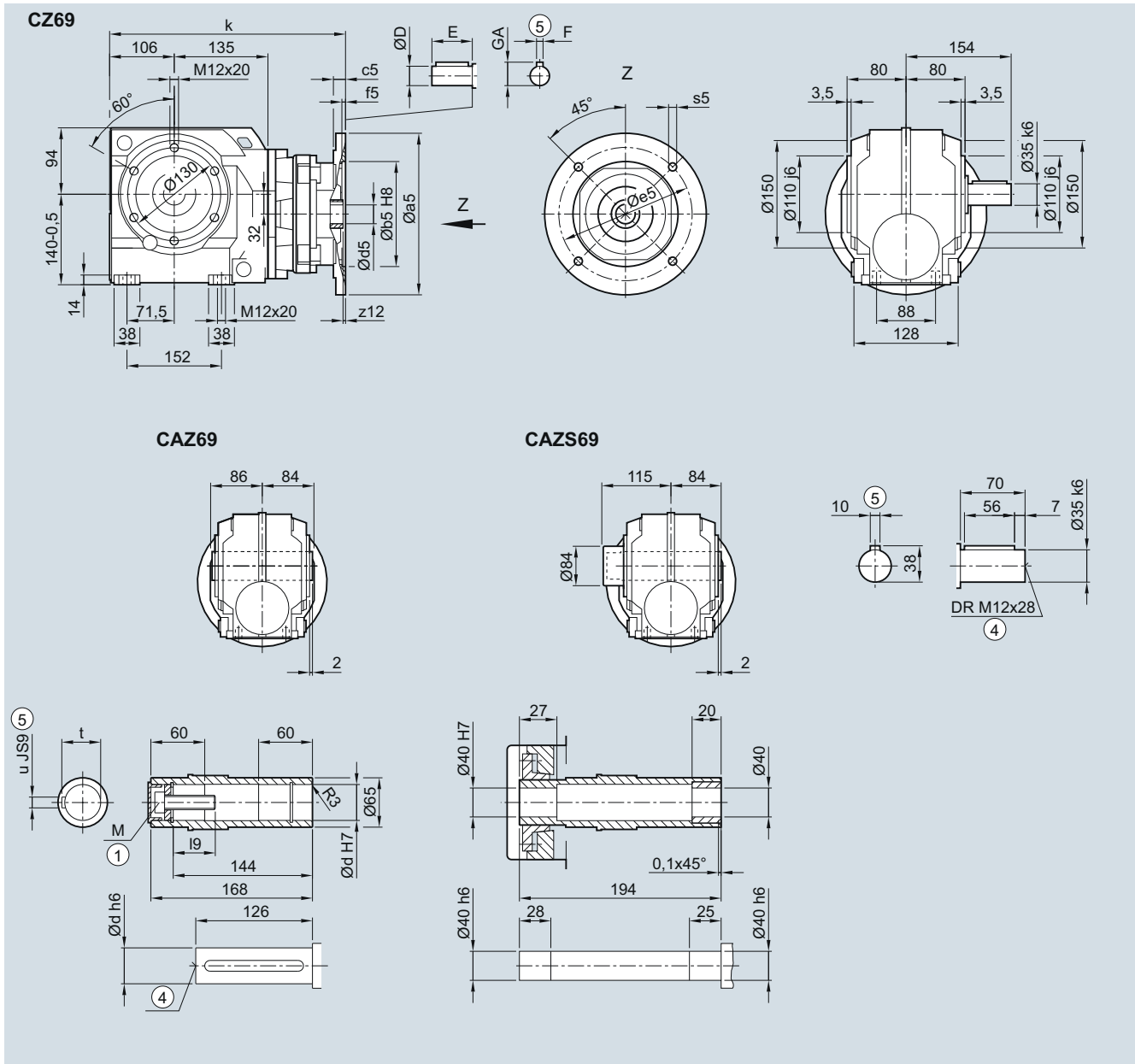

Shaft	d	l9	M	t	u							
	40	47.75	M16	43.3	12							
	45	48.75	M16	48.3	14							
Adapter	a5	b5	c5	f5	e5	s5	z12	d5/D	E	F	GA	k
63	140	95	12	4.5	115	M8	2.5	11	23	4	12.5	309.0
71	160	110	12	4.5	130	M8	2.5	14	30	5	16.0	309.0
80	200	130	15	4.5	165	M10	4.0	19	40	6	12.5	337.0
90	200	130	15	4.5	165	M10	4.0	24	50	8	27.0	337.0
100	250	180	14	5.0	215	M12x21	7.5	28	60	8	31.0	391.5
112	250	180	14	5.0	215	M12x21	7.5	28	60	8	31.0	391.5
1132	300	230	12	6.0	265	M12x20	3.0	38	80	10	41.0	409.0

① ISO 4014

④ DIN 332

⑤ Feather key/keyway DIN 6885

SIMOGEAR Gearboxes

Helical worm gearbox with adapter K4

Dimensions

CAD.69 gearbox in a shaft-mounted design

CAD030K4, CADS030K4

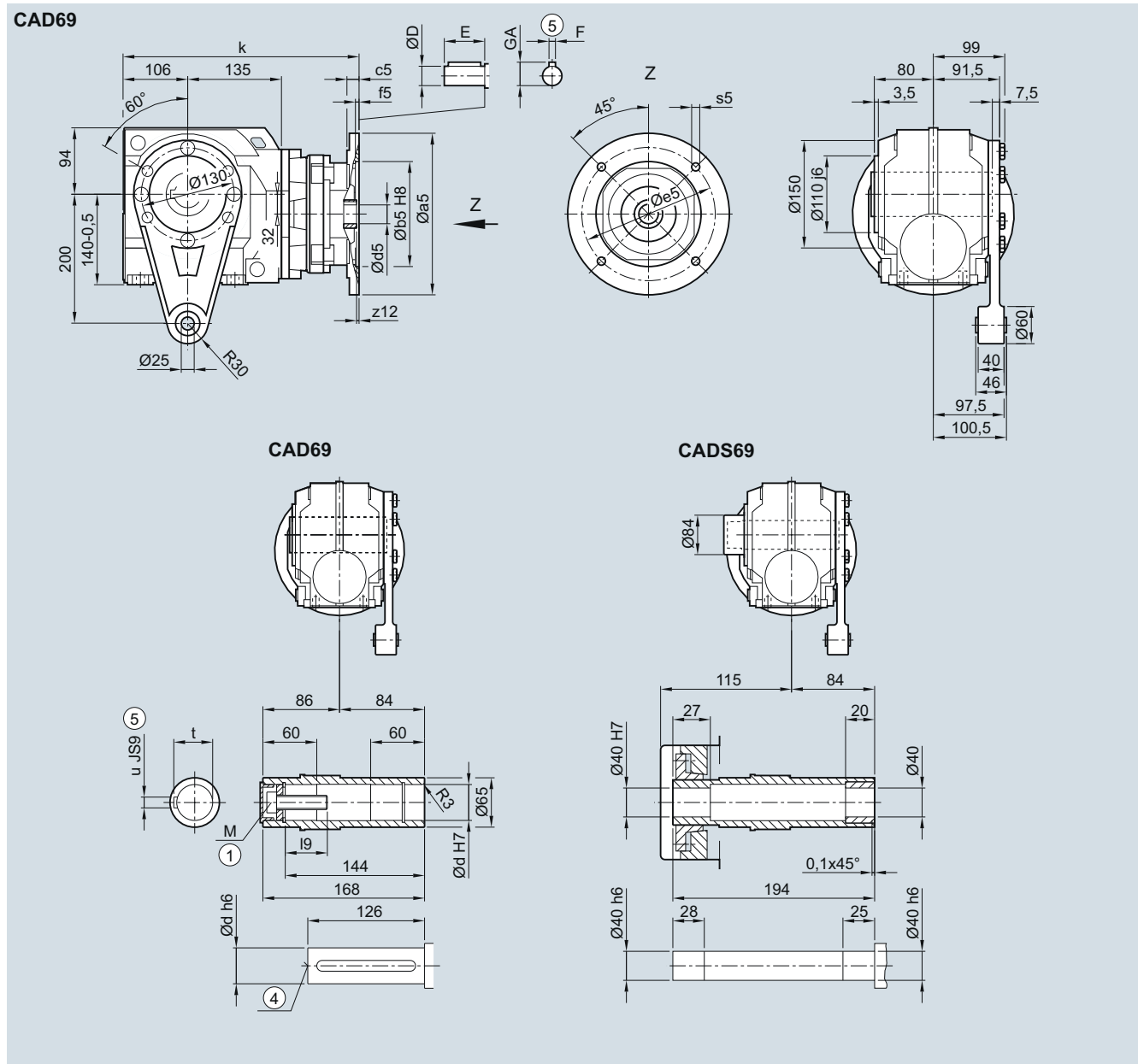

Shaft	d	l9	M	t	u							
	40	47.75	M16	43.3	12							
	45	48.75	M16	48.3	14							
Adapter	a5	b5	c5	f5	e5	s5	z12	d5/D	E	F	GA	k
63	140	95	12	4.5	115	M8	2.5	11	23	4	12.5	309.0
71	160	110	12	4.5	130	M8	2.5	14	30	5	16.0	309.0
80	200	130	15	4.5	165	M10	4.0	19	40	6	12.5	337.0
90	200	130	15	4.5	165	M10	4.0	24	50	8	27.0	337.0
100	250	180	14	5.0	215	M12x21	7.5	28	60	8	31.0	391.5
112	250	180	14	5.0	215	M12x21	7.5	28	60	8	31.0	391.5
132	300	230	12	6.0	265	M12x20	3.0	38	80	10	41.0	409.0

① ISO 4014

④ DIN 332

⑤ Feather key/keyway DIN 6885

C..89 gearbox in a foot-mounted design

C030K4, CA030K4, CAS030K4

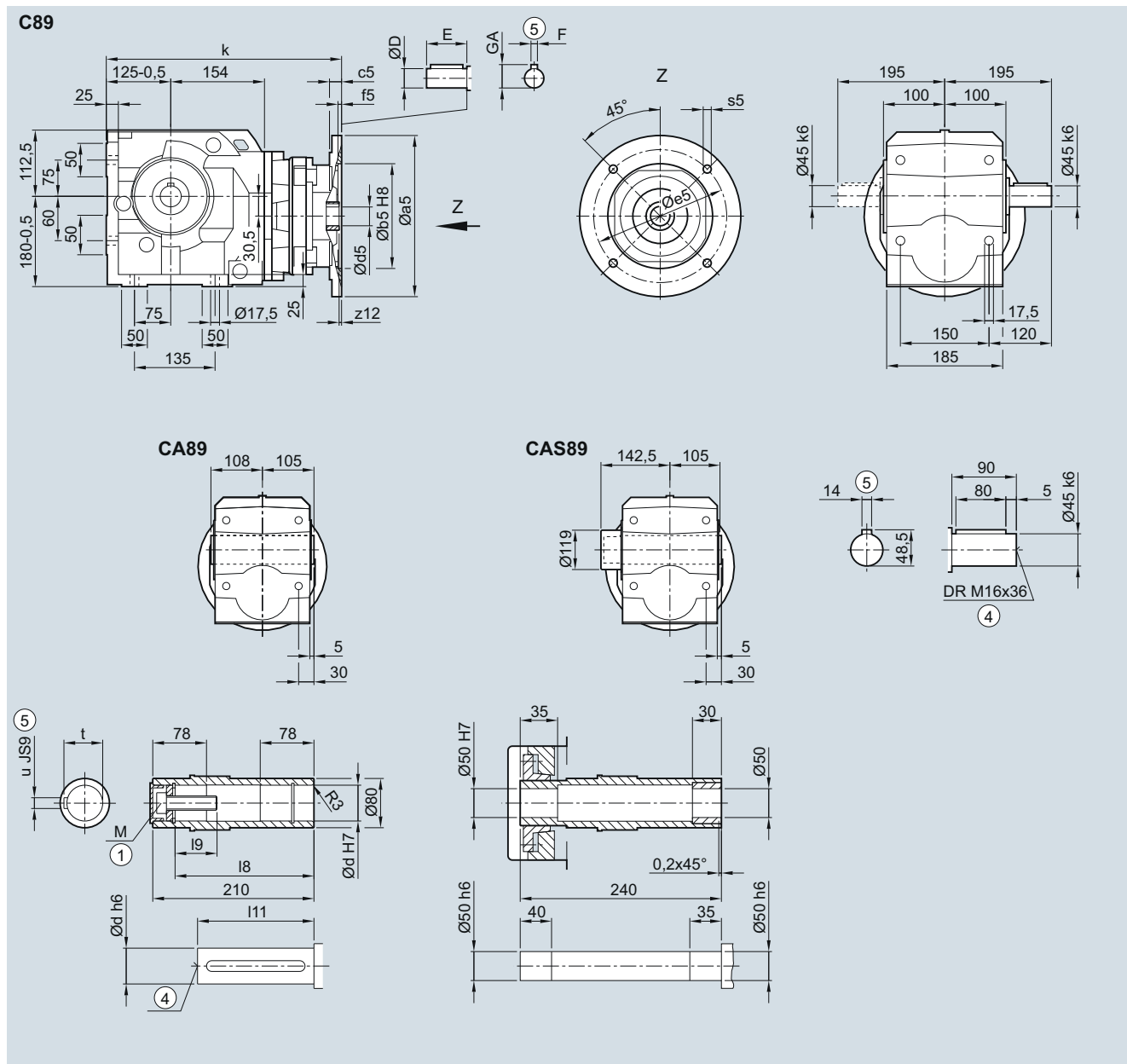

Shaft	d	l9	M	t	u
	50	44.5	M16	53.8	14
	60	57	M20	64.4	18

Adapter	a5	b5	c5	f5	e5	s5	z12	d5/D	E	F	GA	k
71	160	110	12	4.5	130	M8	2.5	14	30	5	16.0	345.0
80	200	130	15	4.5	165	M10	4.0	19	40	6	12.5	345.0
90	200	130	15	4.5	165	M10	4.0	24	50	8	27.0	369.0
100	250	180	14	5.0	215	M12x21	7.5	28	60	8	31.0	423.5
112	250	180	14	5.0	215	M12x21	7.5	28	60	8	31.0	423.5
132	300	230	12	6.0	265	M12x20	3.0	38	80	10	41.0	441.0

① ISO 4014

④ DIN 332

⑤ Feather key/keyway DIN 6885

SIMOGEAR Gearboxes

Helical worm gearbox with adapter K4

Dimensions

C.F.89 gearbox in a flange-mounted design

CF030K4, CAF030K4, CAFS030K4

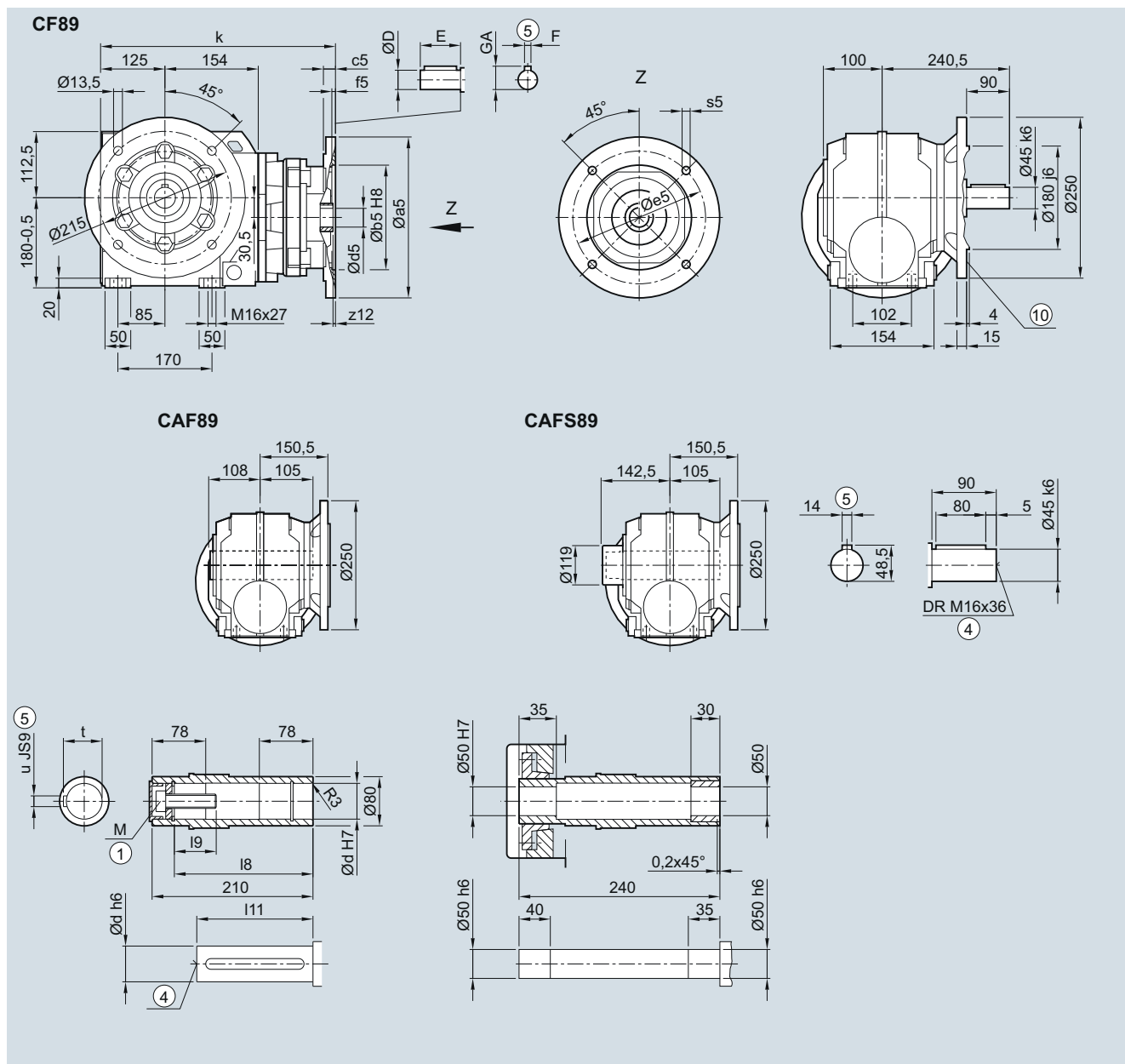

Shaft	d	l9	M	t	u
	50	44.5	M16	53.8	14
	60	57	M20	64.4	18

Dimensions	a5	b5	c5	f5	e5	s5	z12	d5/D	E	F	GA	k
71	160	110	12	4.5	130	M8	2.5	14	30	5	16.0	345.0
80	200	130	15	4.5	165	M10	4.0	19	40	6	12.5	369.0
90	200	130	15	4.5	165	M10	4.0	24	50	8	27.0	369.0
100	250	180	14	5.0	215	M12x21	7.5	28	60	8	31.0	423.5
112	250	180	14	5.0	215	M12x21	7.5	28	60	8	31.0	423.5
132	300	230	12	6.0	265	M12x20	3.0	38	80	10	41.0	441.0

① ISO 4014

④ DIN 332

⑤ Feather key/keyway DIN 6885

SIMOGEAR Gearboxes

Helical worm gearbox with adapter K4

Dimensions

CAD.89 gearbox in a shaft-mounted design

CAD030K4, CADS030K4

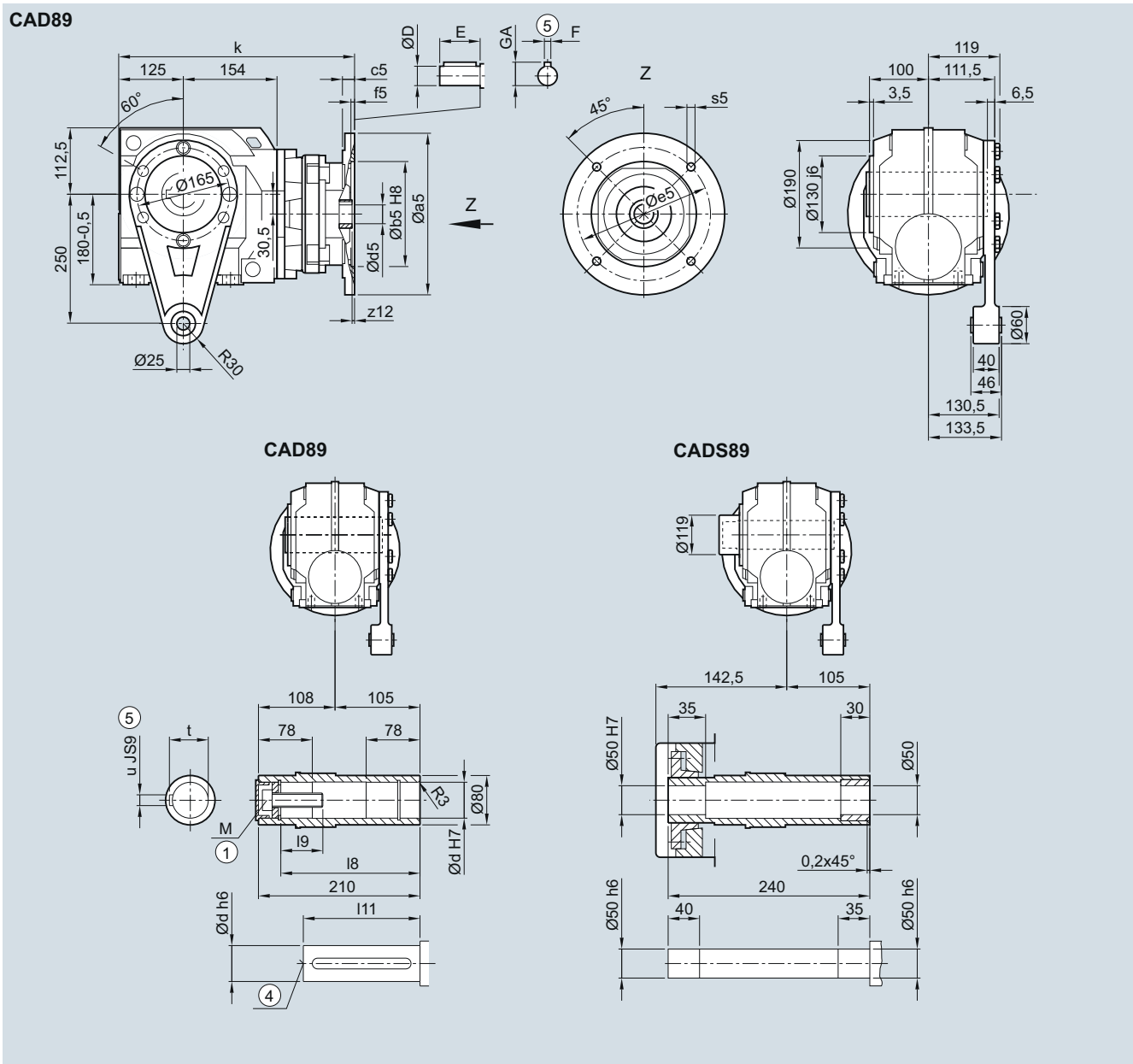

Shaft	d	l9	M	t	u
	50	44.5	M16	53.8	14
	60	57	M20	64.4	18

Adapter	a5	b5	c5	f5	e5	s5	z12	d5/D	E	F	GA	k
71	160	110	12	4.5	130	M8	2.5	14	30	5	16.0	345.0
80	200	130	15	4.5	165	M10	4.0	19	40	6	12.5	369.0
90	200	130	15	4.5	165	M10	4.0	24	50	8	27.0	369.0
100	250	180	14	5.0	215	M12x21	7.5	28	60	8	31.0	423.5
112	250	180	14	5.0	215	M12x21	7.5	28	60	8	31.0	423.5
132	300	230	12	6.0	265	M12x20	3.0	38	80	10	41.0	441.0

① ISO 4014

④ DIN 332

⑤ Feather key/keyway DIN 6885

C...29 to C...89 gearboxes

C...030K2, C.F.030K2, C.Z.030K2, C.D.030K2

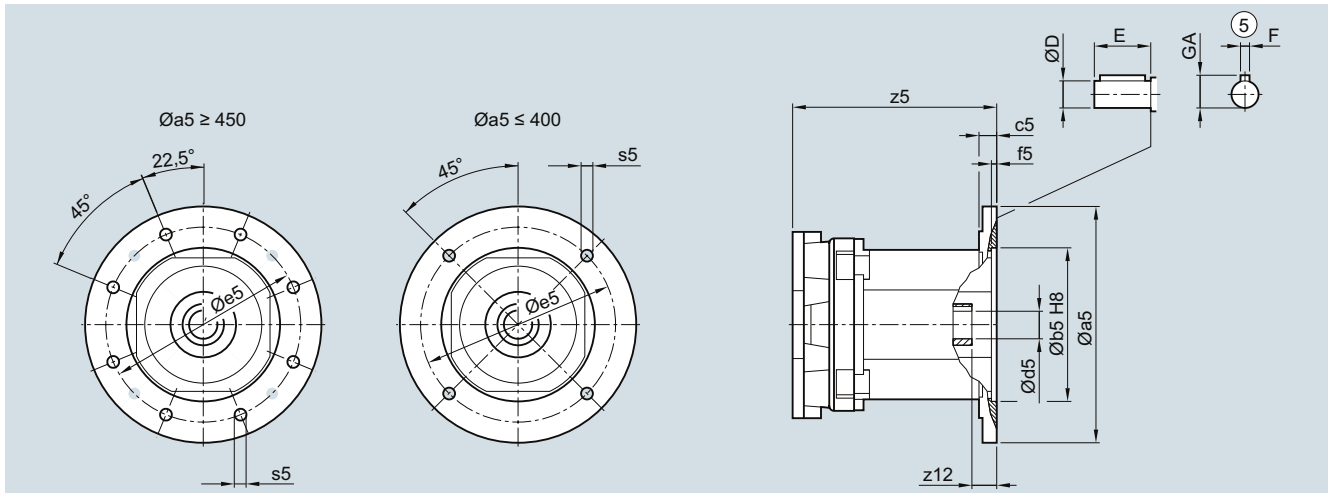

Adapter	a5	b5	c5	f5	e5	s5	z12	d5/D	E	F	GA	z5
C...29												
80	200	130	15	4.5	165	M10	15	19	40	6	21.5	198
90	200	130	15	4.5	165	M10	25	24	50	8	27.0	198
C...39												
80	200	130	15	4.5	165	M10	15	19	40	6	21.5	198
90	200	130	15	4.5	165	M10	25	24	50	8	27.0	198
100	250	180	18	5.0	215	M12	30	28	60	8	31.0	245
C...49												
80	200	130	15	4.5	165	M10	15	19	40	6	21.5	188.5
90	200	130	15	4.5	165	M10	25	24	50	8	27.0	188.5
100	250	180	18	5.0	215	M12	30	28	60	8	31.0	235.5
112	250	180	18	5.0	215	M12	30	28	60	8	31.0	235.5
C...69												
80	200	130	15	4.5	165	M10	15	19	40	6	21.5	188.5
90	200	130	15	4.5	165	M10	25	24	50	8	27.0	188.5
100	250	180	18	5.0	215	M12	30	28	60	8	31.0	235.5
112	250	180	18	5.0	215	M12	30	28	60	8	31.0	235.5
132	300	230	18	5.0	265	M12	45	38	80	10	41.0	313.5
C...89												
80	200	130	15	4.5	165	M10	15	19	40	6	21.5	182.5
90	200	130	15	4.5	165	M10	25	24	50	8	27.0	182.5
100	250	180	18	5.0	215	M12	30	28	60	8	31.0	229.5
112	250	180	18	5.0	215	M12	30	28	60	8	31.0	229.5
132	300	230	18	5.0	265	M12	45	38	80	10	41.0	307.5

SIMOGEAR Gearboxes

Helical worm gearbox with adapter KQ

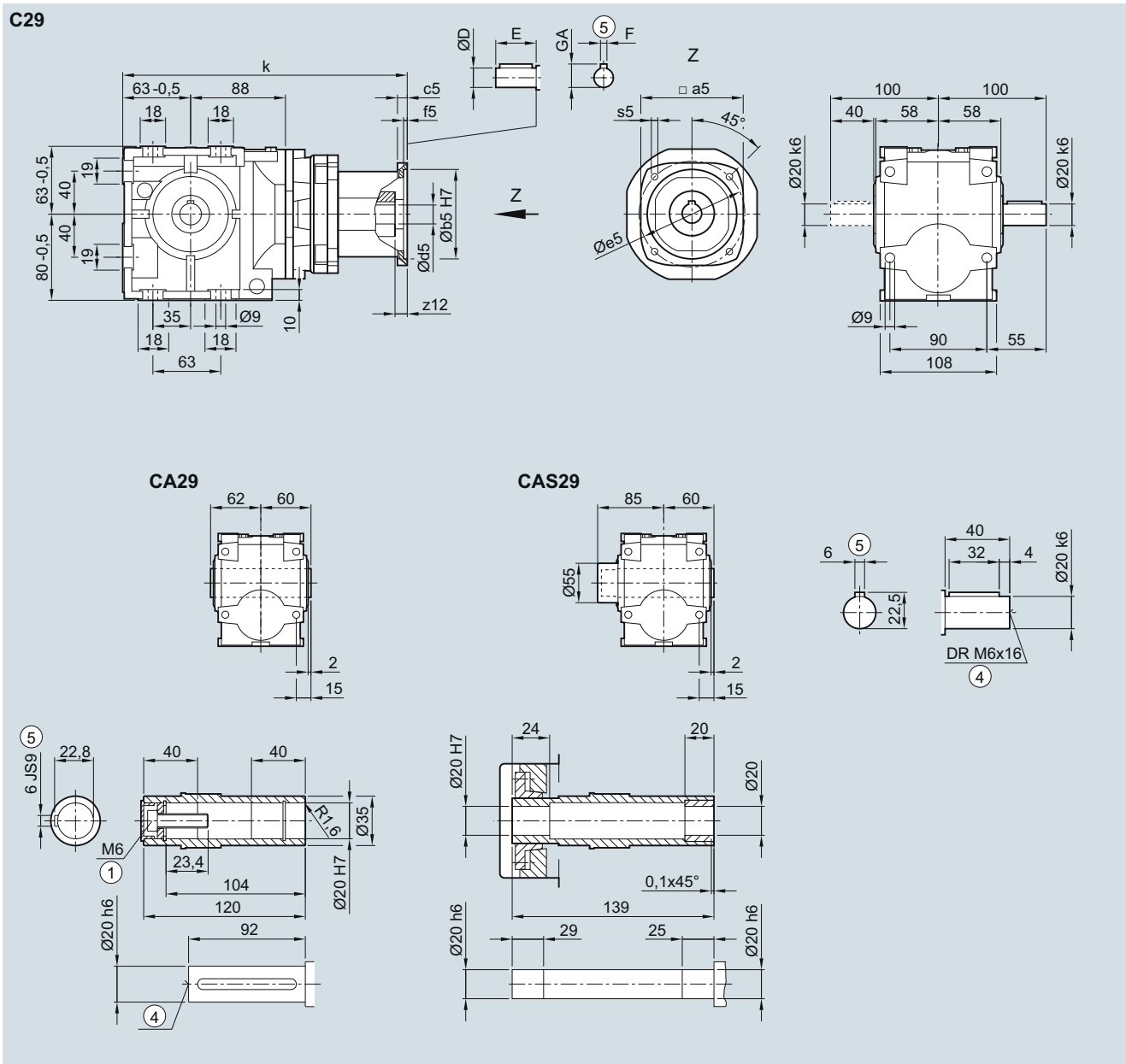
Dimensions**C..29 gearbox in a foot-mounted design****CF030KQ, CAF030KQ, CAFS030KQ**

Adapter	a5	b5	c5	f5	e5	s5	z12	d5/D	E	F	GA	k
703	71.6	60	9	4.0	75	M5	18	14	30	5	16.0	250.5
704	96.5	80	10	4.0	100	M6	14	19	40	6	21.5	297.5
706	126.0	110	12	4.5	130	M8	15	24	50	8	27.0	310.5

① ISO 4014

④ DIN 332

⑤ Feather key/keyway DIN 6885

SIMOGEAR Gearboxes

Helical worm gearbox with adapter KQ

Dimensions

C.Z.29 gearbox in a housing flange design

CZ030KQ, CAZ030KQ, CAZS030KQ

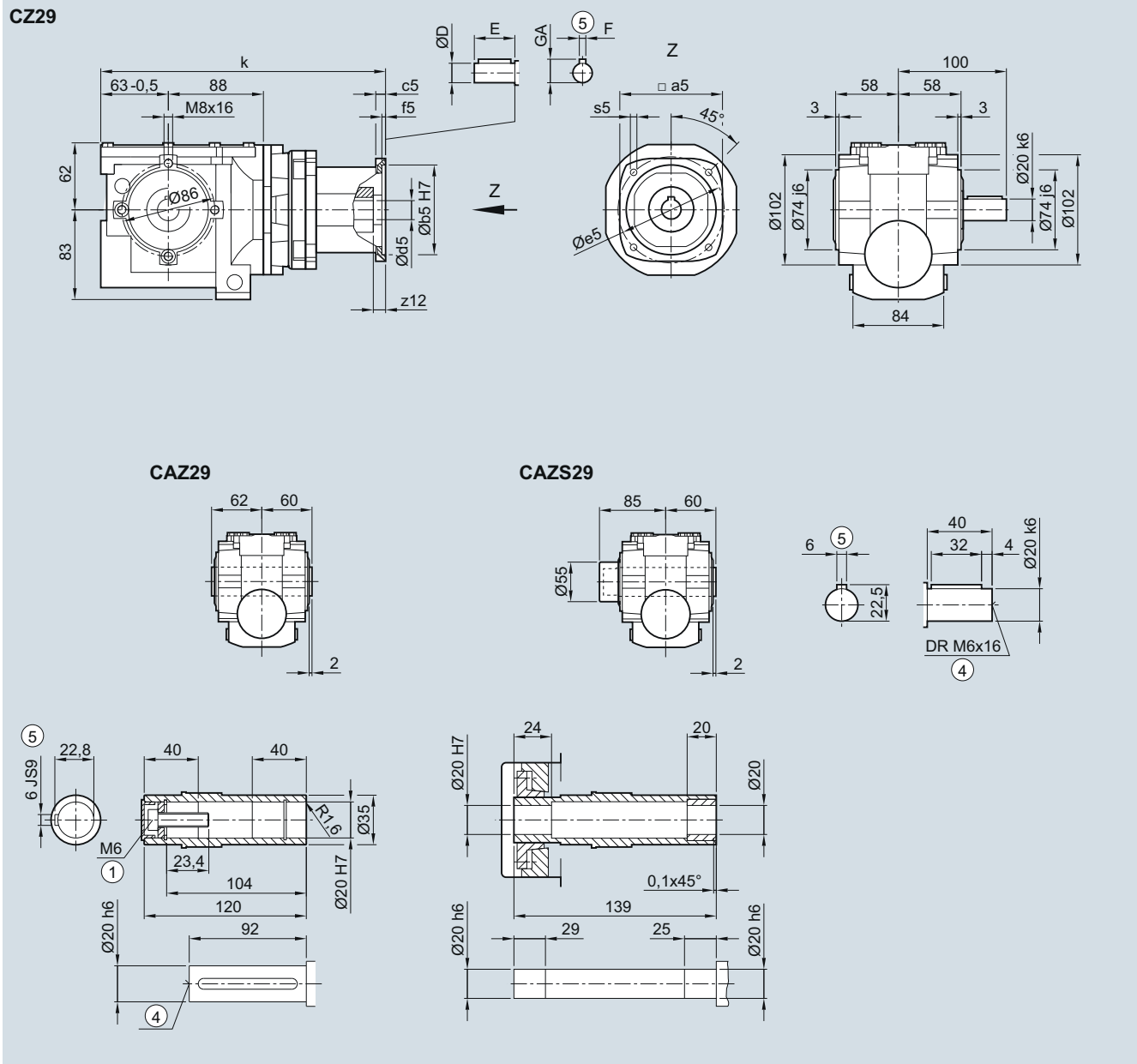

Adapter	a5	b5	c5	f5	e5	s5	z12	d5/D	E	F	GA	k
703	71.6	60	9	4.0	75	M5	18	14	30	5	16.0	250.0
704	96.5	80	10	4.0	100	M6	14	19	40	6	21.5	297.0
706	126.0	110	12	4.5	130	M8	15	24	50	8	27.0	310.0

① ISO 4014

④ DIN 332

⑤ Feather key/keyway DIN 6885

CAD.29 gearbox in a shaft-mounted design

CAD030KQ, CADS030KQ

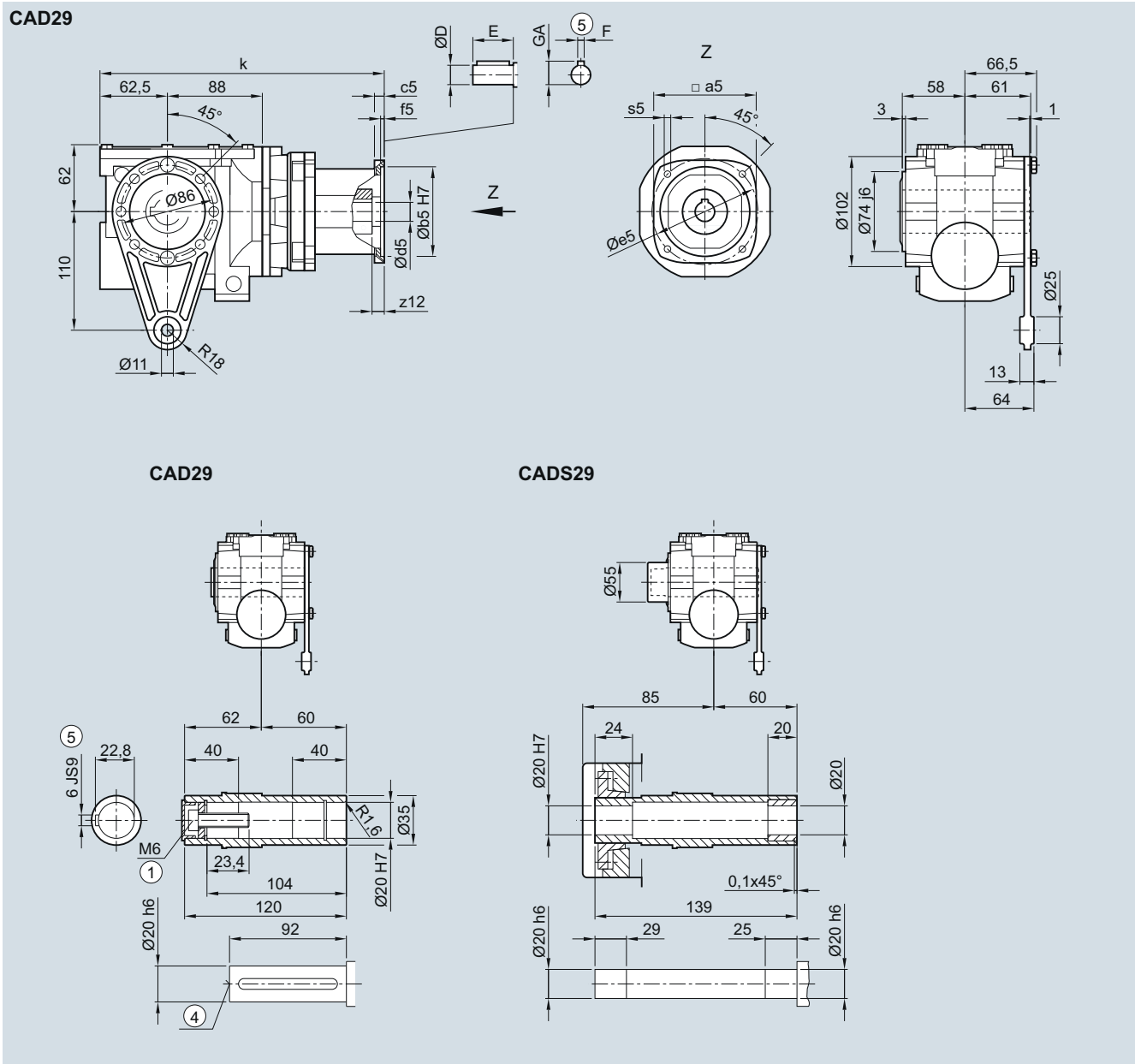

Adapter	a5	b5	c5	f5	e5	s5	z12	d5/D	E	F	GA	k
703	71.6	60	9	4.0	75	M5	18	14	30	5	16.0	250.0
704	96.5	80	10	4.0	100	M6	14	19	40	6	21.5	297.0
706	126.0	110	12	4.5	130	M8	15	24	50	8	27.0	310.0

① ISO 4014

④ DIN 332

⑤ Feather key/keyway DIN 6885

SIMOGEAR Gearboxes

Helical worm gearbox with adapter KQ

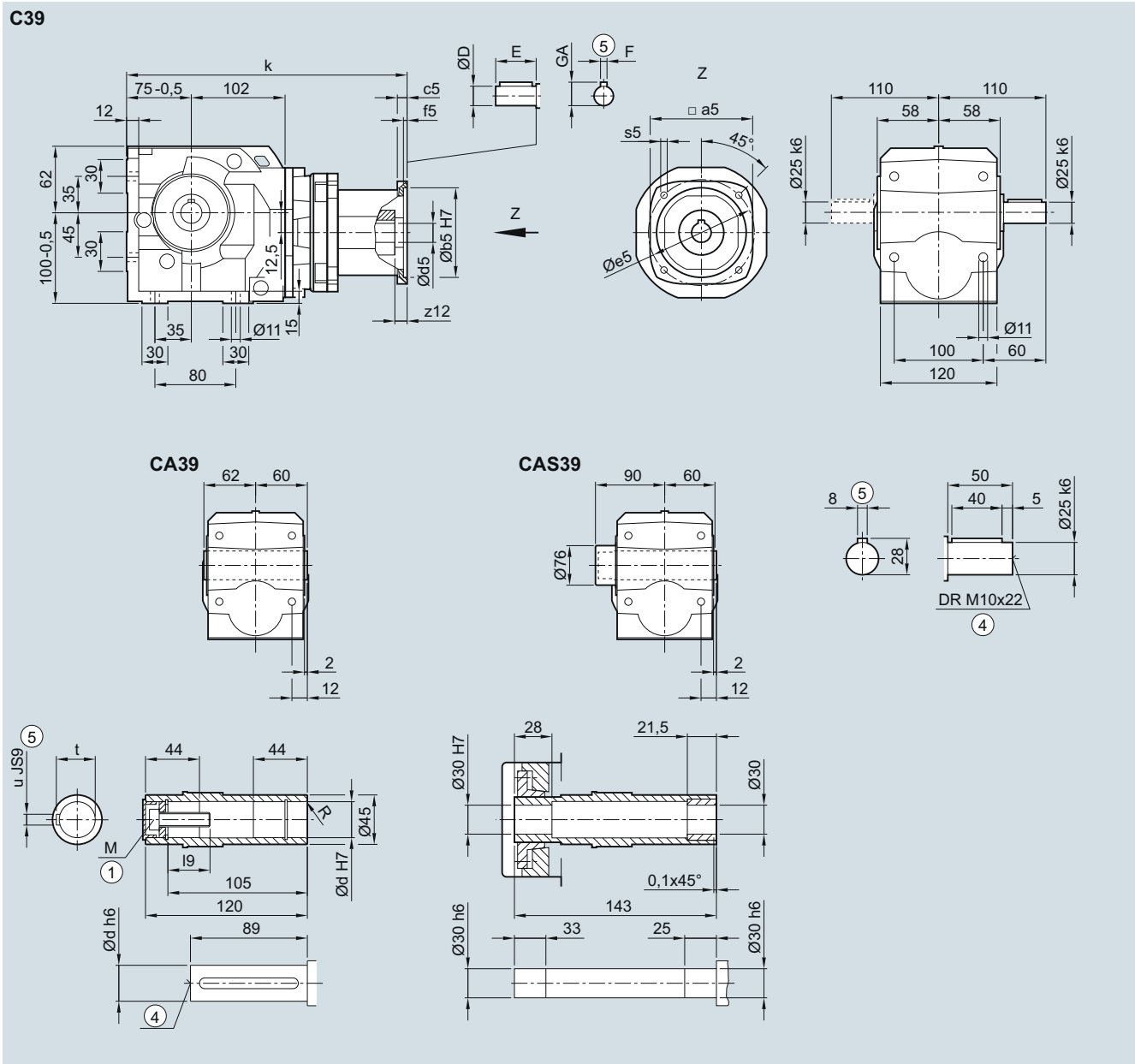
Dimensions**C..39 gearbox in a foot-mounted design****CF030KQ, CAF030KQ, CAFS030KQ**

Adapter	a5	b5	c5	f5	e5	s5	z12	d5/D	E	F	GA	k
703	71.6	60	9	4.0	75	M5	18.0	14	30	5	16.0	276.5
704	96.5	80	10	4.0	100	M6	14.0	19	40	6	21.5	323.5
706	126.0	110	12	4.5	130	M8	15.0	24	50	8	27.0	336.5

① ISO 4014

④ DIN 332

⑤ Feather key/keyway DIN 6885

C.F.39 gearbox in a flange-mounted design

CF030KQ, CAF030KQ, CAFS030KQ

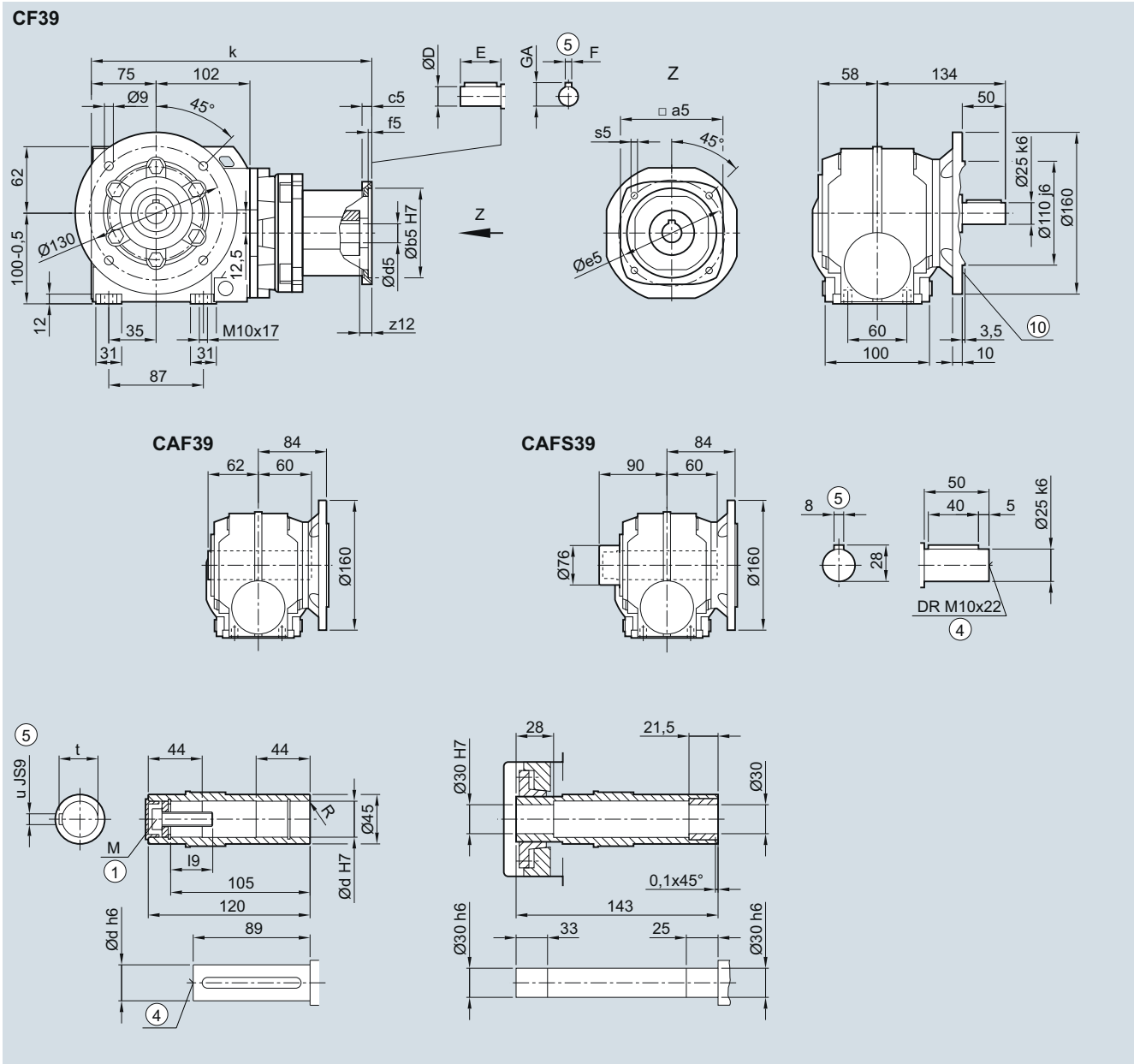

Adapter	a5	b5	c5	f5	e5	s5	z12	d5/D	E	F	GA	k
703	71.6	60	9	4.0	75	M5	18.0	14	30	5	16.0	276.5
704	96.5	80	10	4.0	100	M6	14.0	19	40	6	21.5	323.5
706	126.0	110	12	4.5	130	M8	15.0	24	50	8	27.0	336.5

① ISO 4014

④ DIN 332

⑤ Feather key/keyway DIN 6885

SIMOGEAR Gearboxes

Helical worm gearbox with adapter KQ

Dimensions

C.Z.39 gearbox in a housing flange design

CZ030KQ, CAZ030KQ, CAZS030KQ

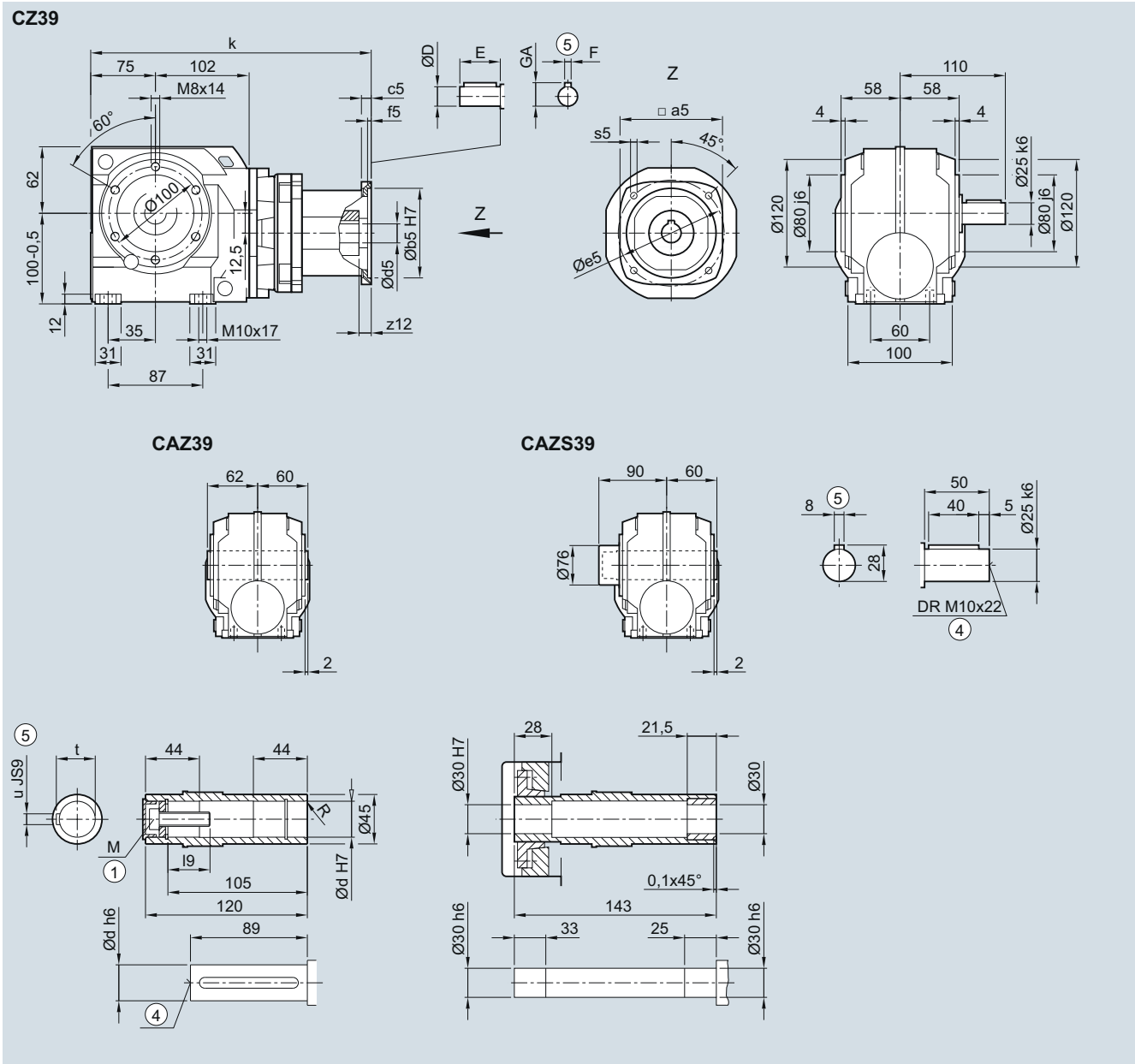

Adapter	a5	b5	c5	f5	e5	s5	z12	d5/D	E	F	GA	k
703	71.6	60	9	4.0	75	M5	18.0	14	30	5	16.0	276.5
704	96.5	80	10	4.0	100	M6	14.0	19	40	6	21.5	323.5
706	126.0	110	12	4.5	130	M8	15.0	24	50	8	27.0	336.5

① ISO 4014

④ DIN 332

⑤ Feather key/keyway DIN 6885

CAD.39 gearbox in a shaft-mounted design

CAD030KQ, CADS030KQ

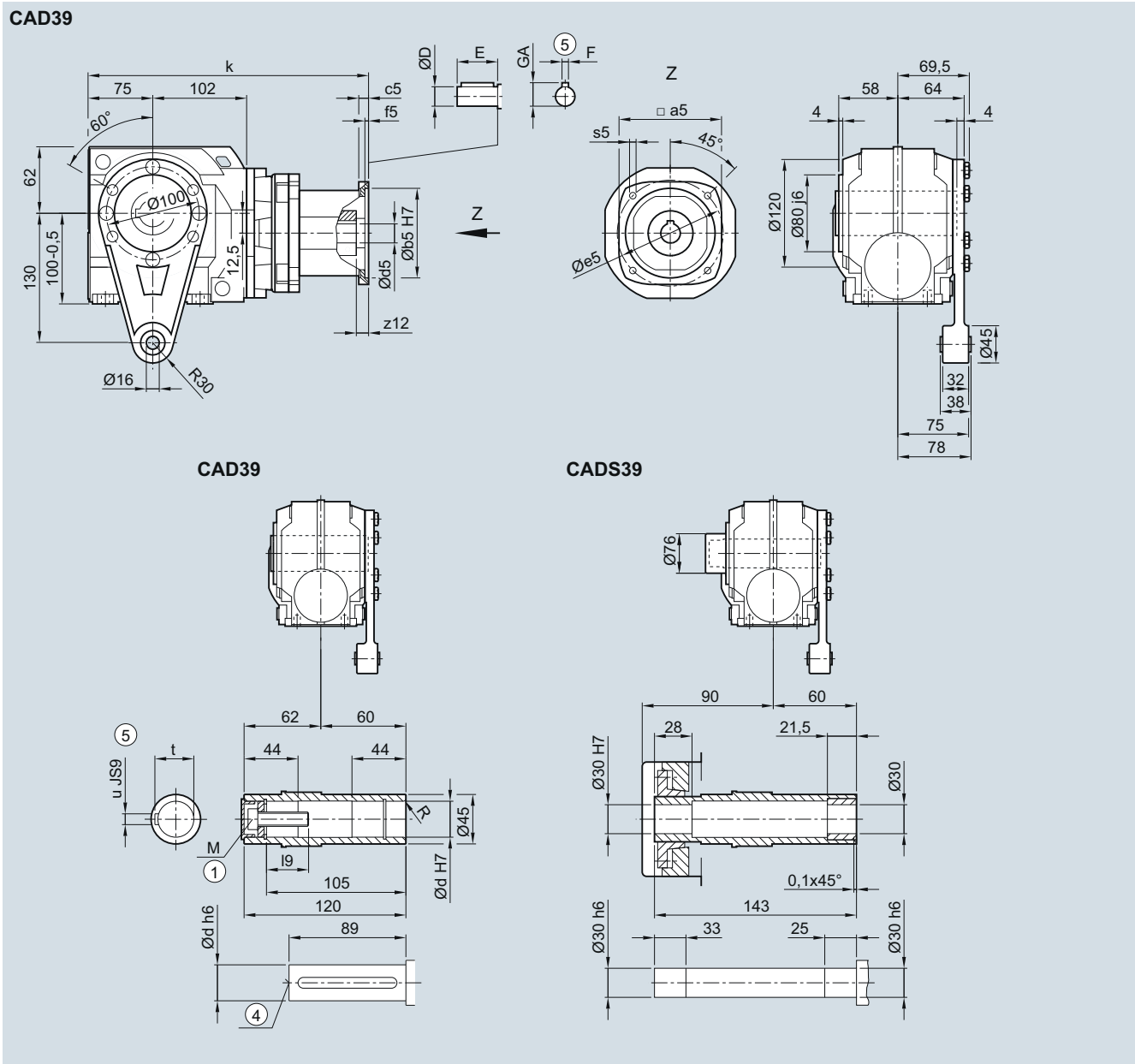

Adapter	a5	b5	c5	f5	e5	s5	z12	d5/D	E	F	GA	k
703	71.6	60	9	4.0	75	M5	18.0	14	30	5	16.0	276.5
704	96.5	80	10	4.0	100	M6	14.0	19	40	6	21.5	323.5
706	126.0	110	12	4.5	130	M8	15.0	24	50	8	27.0	336.5

① ISO 4014

④ DIN 332

⑤ Feather key/keyway DIN 6885

SIMOGEAR Gearboxes

Helical worm gearbox with adapter KQ

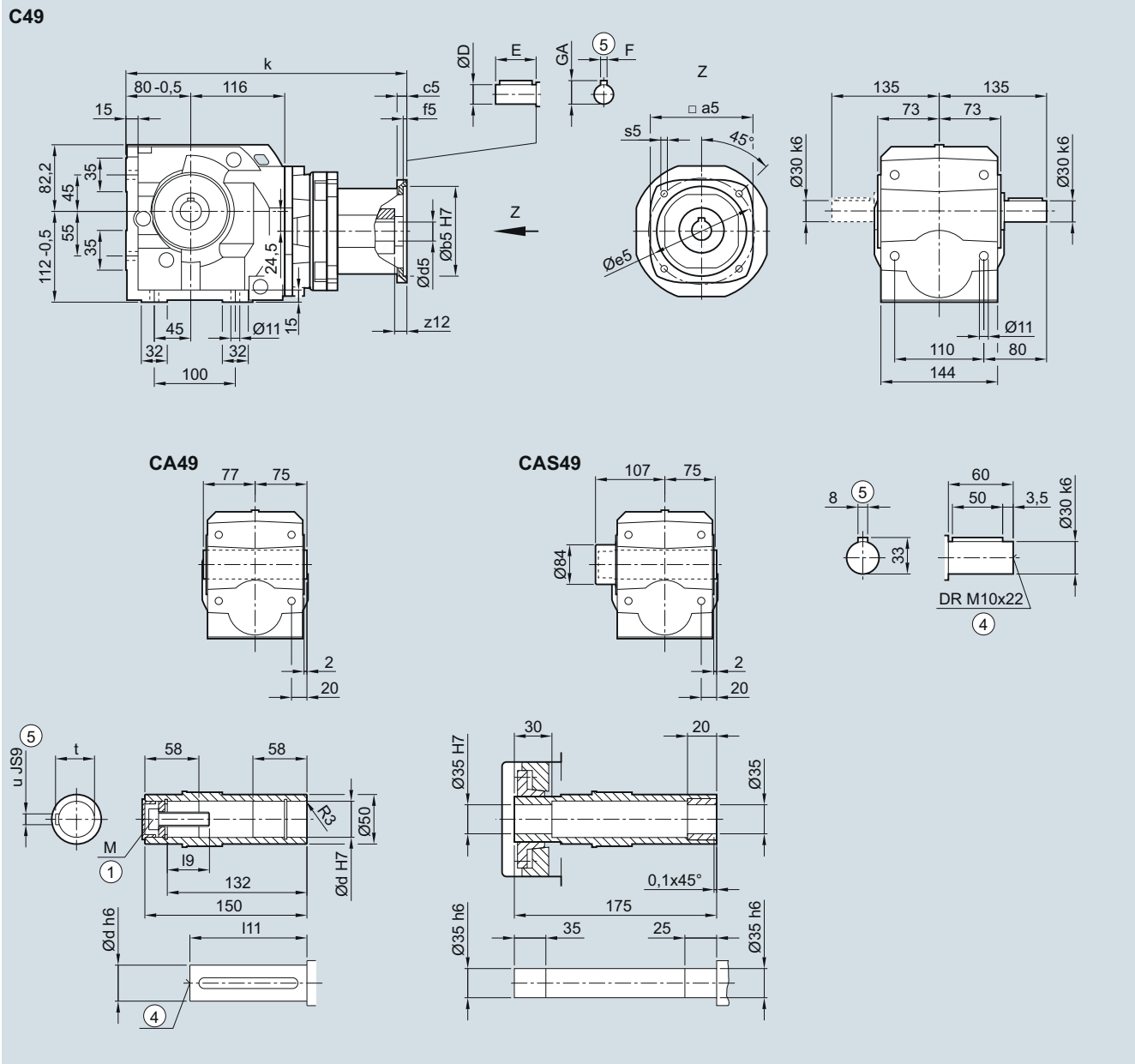
Dimensions**C..49 gearbox in a foot-mounted design****CF030KQ, CAF030KQ, CAFS030KQ**

Adapter	a5	b5	c5	f5	e5	s5	z12	d5/D	E	F	GA	k
703	71.6	60	9	4.0	75	M5	18.0	14	30	5	16.0	286.0
704	96.5	80	10	4.0	100	M6	14.0	19	40	6	21.5	333.0
706	126.0	110	12	4.5	130	M8	15.0	24	50	8	27.0	346.0
708	155.0	130	15	4.5	165	M10	23.5	32	58	10	35.0	389.5

① ISO 4014

④ DIN 332

⑤ Feather key/keyway DIN 6885

CF.49 gearbox in a flange-mounted design

CF030KQ, CAF030KQ, CAFS030KQ

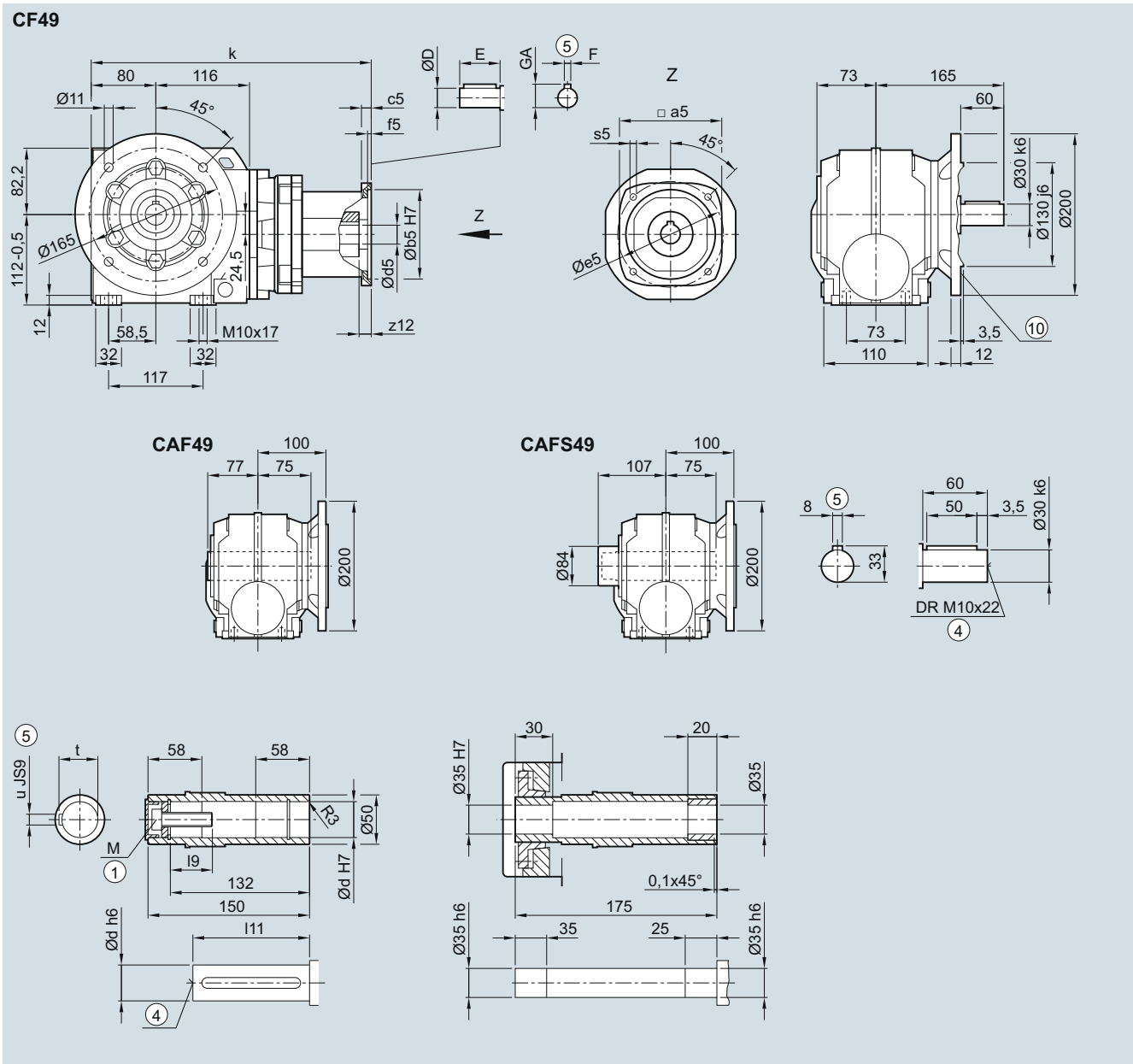

Adapter	a5	b5	c5	f5	e5	s5	z12	d5/D	E	F	GA	k
703	71.6	60	9	4.0	75	M5	18.0	14	30	5	16.0	286.0
704	96.5	80	10	4.0	100	M6	14.0	19	40	6	21.5	333.0
706	126.0	110	12	4.5	130	M8	15.0	24	50	8	27.0	346.0
708	155.0	130	15	4.5	165	M10	23.5	32	58	10	35.0	389.5

① ISO 4014

④ DIN 332

⑤ Feather key/keyway DIN 6885

SIMOGEAR Gearboxes

Helical worm gearbox with adapter KQ

Dimensions

C.Z.49 gearbox in a housing flange design

CZ030, CAZ030, CAZS030

CZ49

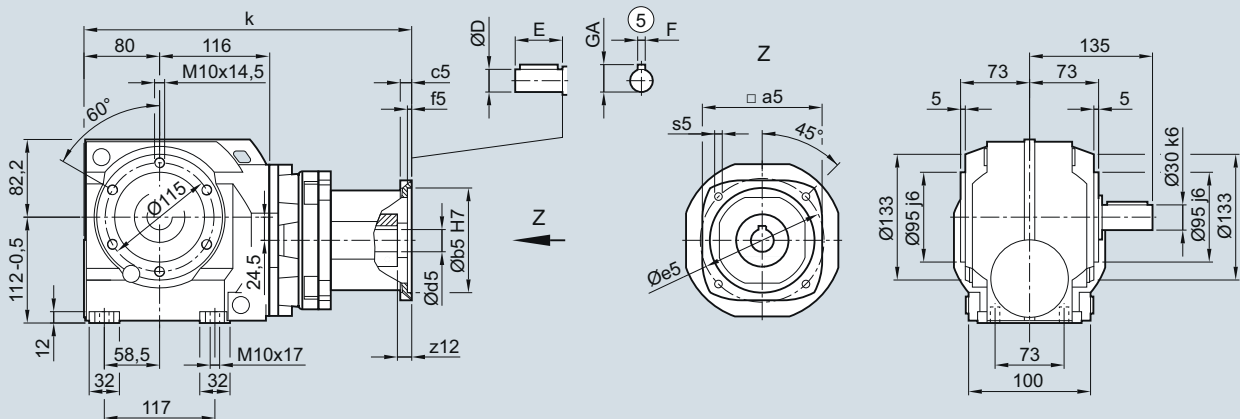

CAZ49

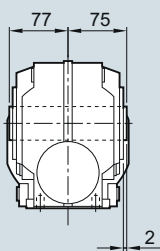

CAZS49

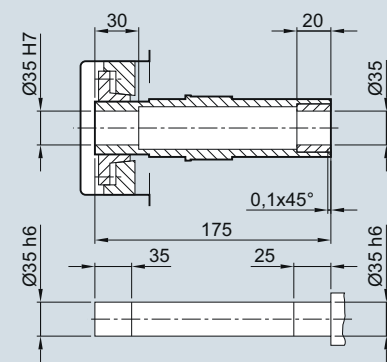
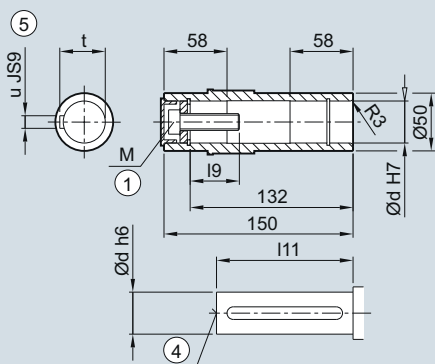
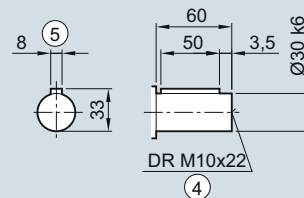
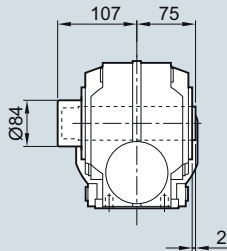

Adapter	a5	b5	c5	f5	e5	s5	z12	d5/D	E	F	GA	k
703	71.6	60	9	4.0	75	M5	18.0	14	30	5	16.0	286.0
704	96.5	80	10	4.0	100	M6	14.0	19	40	6	21.5	333.0
706	126.0	110	12	4.5	130	M8	15.0	24	50	8	27.0	346.0
708	155.0	130	15	4.5	165	M10	23.5	32	58	10	35.0	389.5

① ISO 4014

④ DIN 332

⑤ Feather key/keyway DIN 6885

CAD.49 gearbox in a shaft-mounted design

CAD030KQ, CADS030KQ

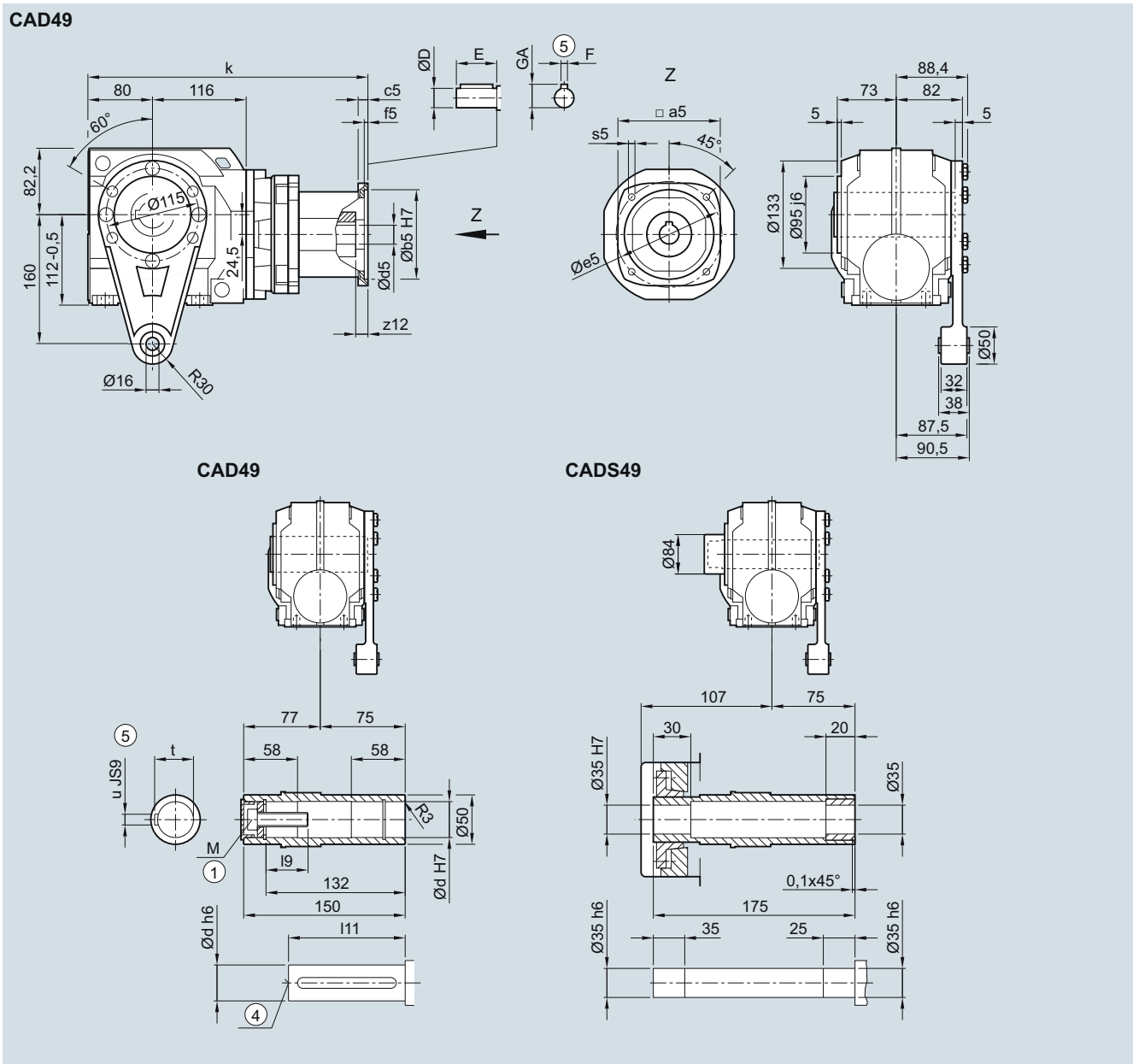

Adapter	a5	b5	c5	f5	e5	s5	z12	d5/D	E	F	GA	k
703	71.6	60	9	4.0	75	M5	18.0	14	30	5	16.0	286.0
704	96.5	80	10	4.0	100	M6	14.0	19	40	6	21.5	333.0
706	126.0	110	12	4.5	130	M8	15.0	24	50	8	27.0	346.0
708	155.0	130	15	4.5	165	M10	23.5	32	58	10	35.0	389.5

① ISO 4014

④ DIN 332

⑤ Feather key/keyway DIN 6885

SIMOGEAR Gearboxes

Helical worm gearbox with adapter KQ

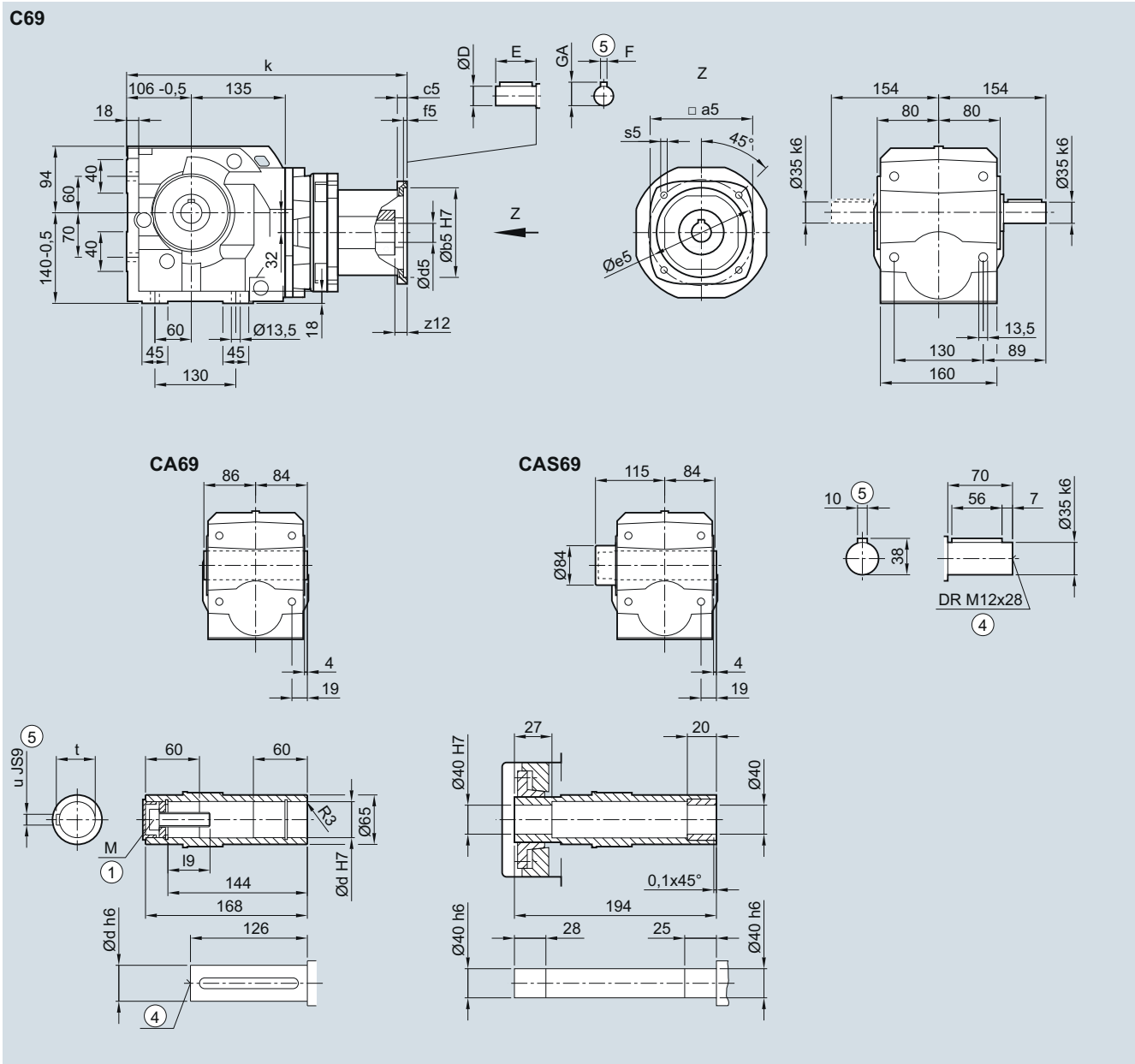
Dimensions**C..69 gearbox in a foot-mounted design****CF030KQ, CAF030KQ, CAFS030KQ**

Adapter	a5	b5	c5	f5	e5	s5	z12	d5/D	E	F	GA	k
703	71.6	60	9	4.0	75	M5	18.0	14	30	5	16.0	331.0
704	96.5	80	10	4.0	100	M6	14.0	19	40	6	21.5	378.0
706	126.0	110	12	4.5	130	M8	15.0	24	50	8	27.0	391.0
708	155.0	130	15	4.5	165	M10	23.5	32	58	10	35.0	434.5
710	192.5	180	18	5.0	215	M12	33.0	38	80	10	41.0	503.5

① ISO 4014

④ DIN 332

⑤ Feather key/keyway DIN 6885

CF.69 gearbox in a flange-mounted design

CF030KQ, CAF030KQ, CAFS030KQ

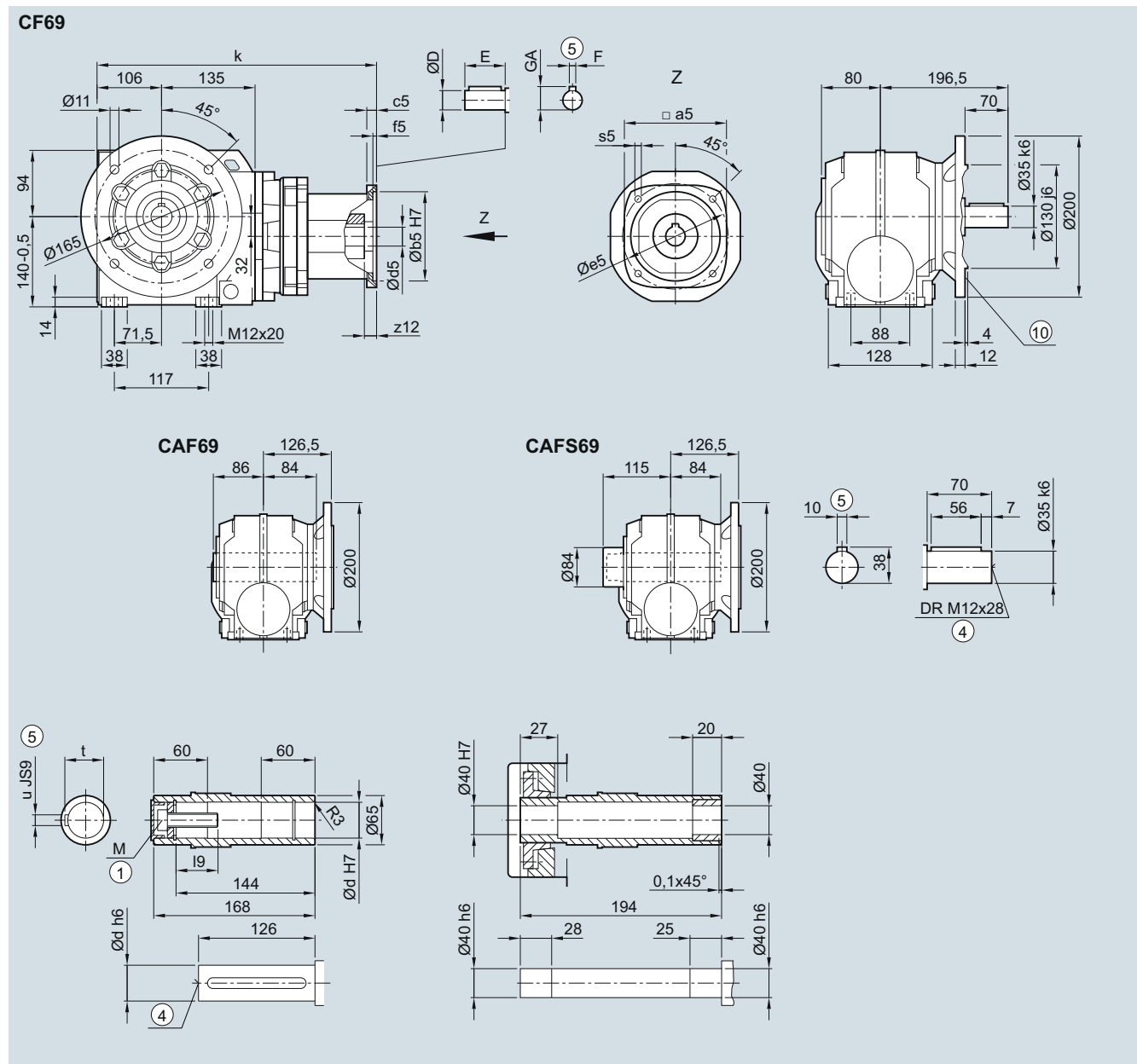

Adapter	a5	b5	c5	f5	e5	s5	z12	d5/D	E	F	GA	k
703	71.6	60	9	4.0	75	M5	18.0	14	30	5	16.0	331.0
704	96.5	80	10	4.0	100	M6	14.0	19	40	6	21.5	378.0
706	126.0	110	12	4.5	130	M8	15.0	24	50	8	27.0	391.0
708	155.0	130	15	4.5	165	M10	23.5	32	58	10	35.0	434.5
710	192.5	180	18	5.0	215	M12	33.0	38	80	10	41.0	503.5

① ISO 4014

④ DIN 332

⑤ Feather key/keyway DIN 6885

SIMOGEAR Gearboxes

Helical worm gearbox with adapter KQ

Dimensions

C.Z.69 gearbox in a housing flange design

CZ030KQ, CAZ030KQ, CAZS030KQ

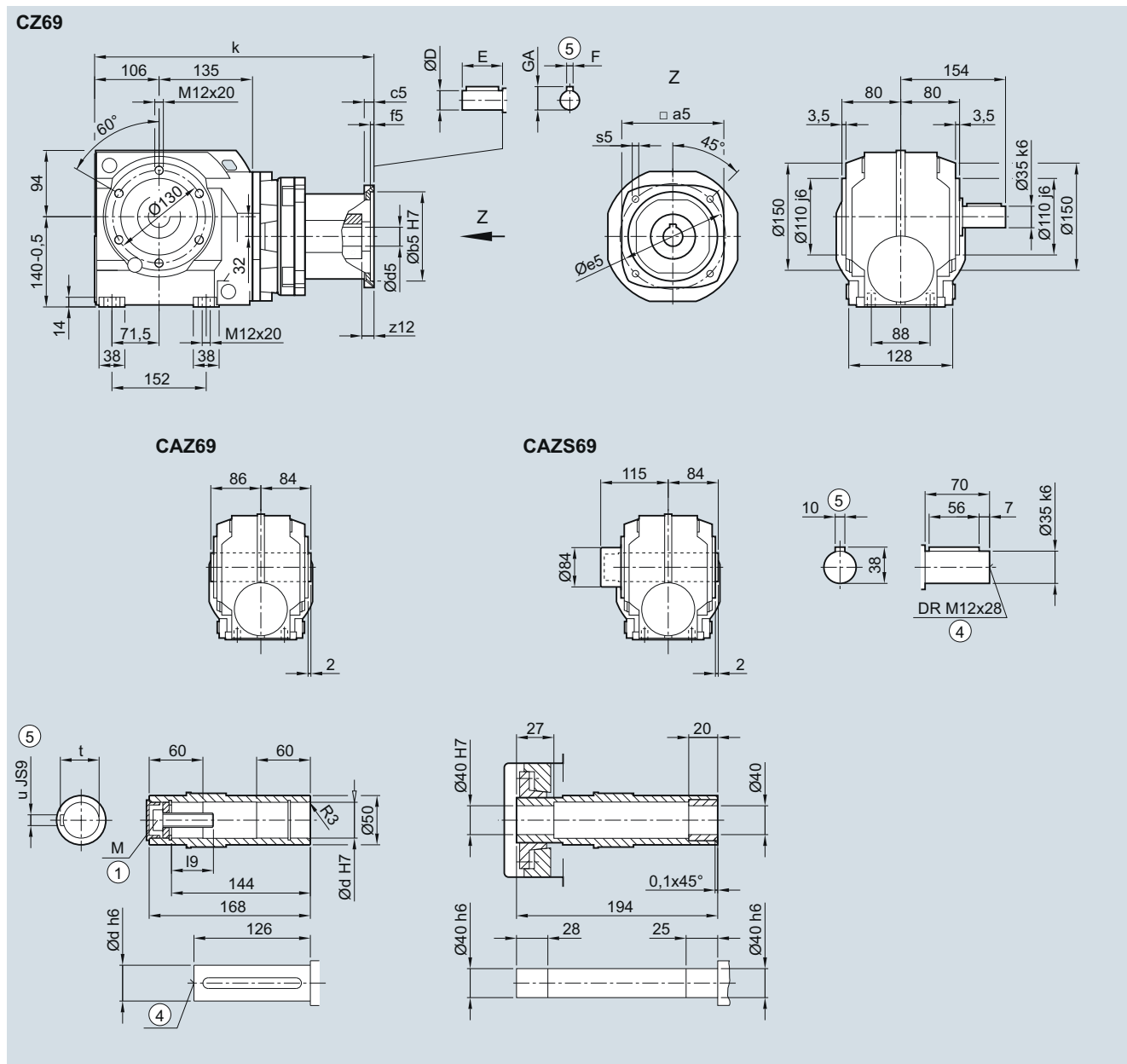

Adapter	a5	b5	c5	f5	e5	s5	z12	d5/D	E	F	GA	k
703	71.6	60	9	4.0	75	M5	18.0	14	30	5	16.0	331.0
704	96.5	80	10	4.0	100	M6	14.0	19	40	6	21.5	378.0
706	126.0	110	12	4.5	130	M8	15.0	24	50	8	27.0	391.0
708	155.0	130	15	4.5	165	M10	23.5	32	58	10	35.0	434.5
710	192.5	180	18	5.0	215	M12	33.0	38	80	10	41.0	503.5

① ISO 4014

④ DIN 332

⑤ Feather key/keyway DIN 6885

CAD.69 gearbox in a shaft-mounted design

CAD030KQ, CADS030KQ

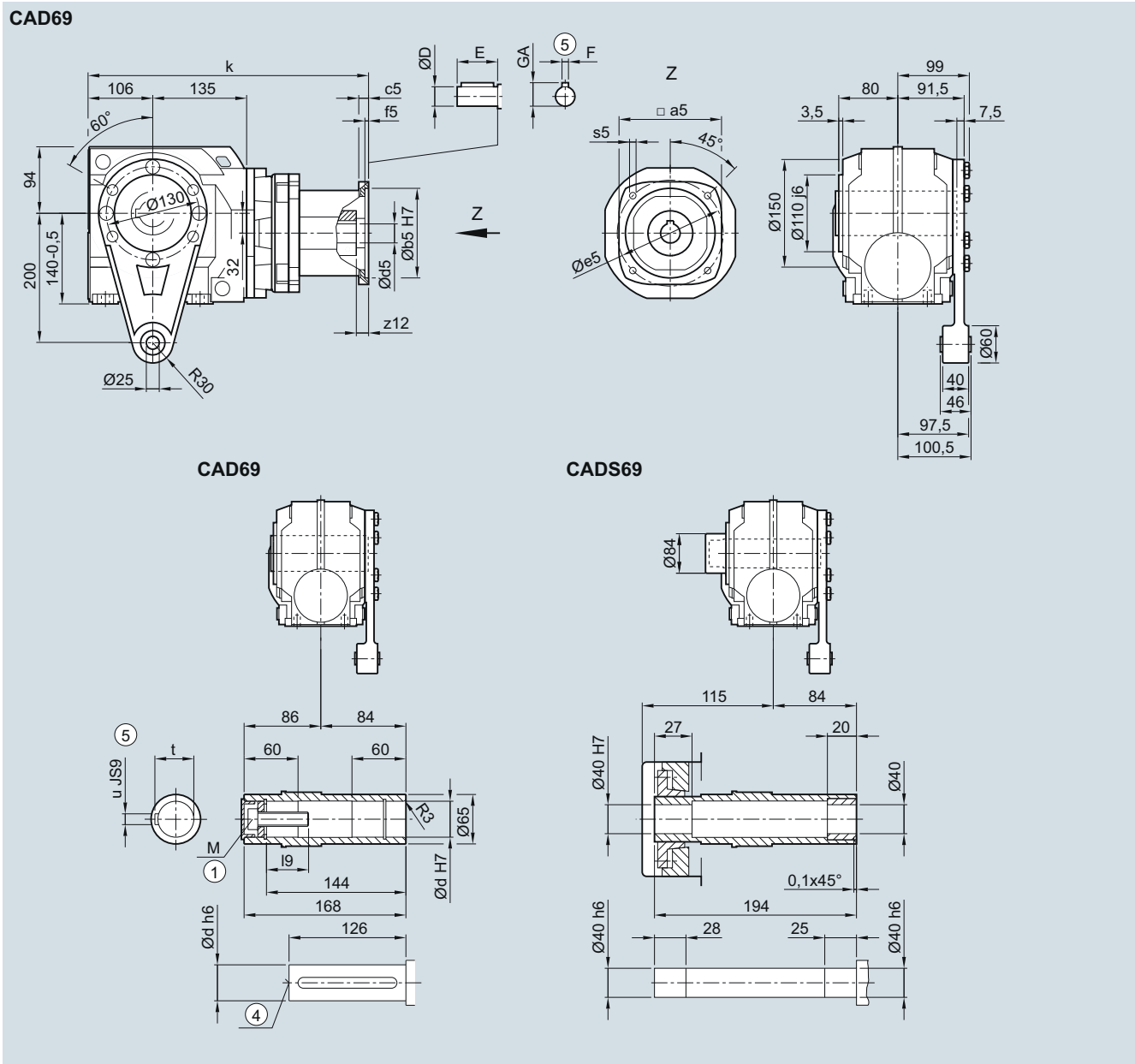

6

Adapter	a5	b5	c5	f5	e5	s5	z12	d5/D	E	F	GA	k
703	71.6	60	9	4.0	75	M5	18.0	14	30	5	16.0	331.0
704	96.5	80	10	4.0	100	M6	14.0	19	40	6	21.5	378.0
706	126.0	110	12	4.5	130	M8	15.0	24	50	8	27.0	391.0
708	155.0	130	15	4.5	165	M10	23.5	32	58	10	35.0	434.5
710	192.5	180	18	5.0	215	M12	33.0	38	80	10	41.0	503.5

① ISO 4014

④ DIN 332

⑤ Feather key/keyway DIN 6885

SIMOGEAR Gearboxes

Helical worm gearbox with adapter KQ

Dimensions

C..89 gearbox in a foot-mounted design

CF030KQ, CAF030KQ, CAFS030KQ

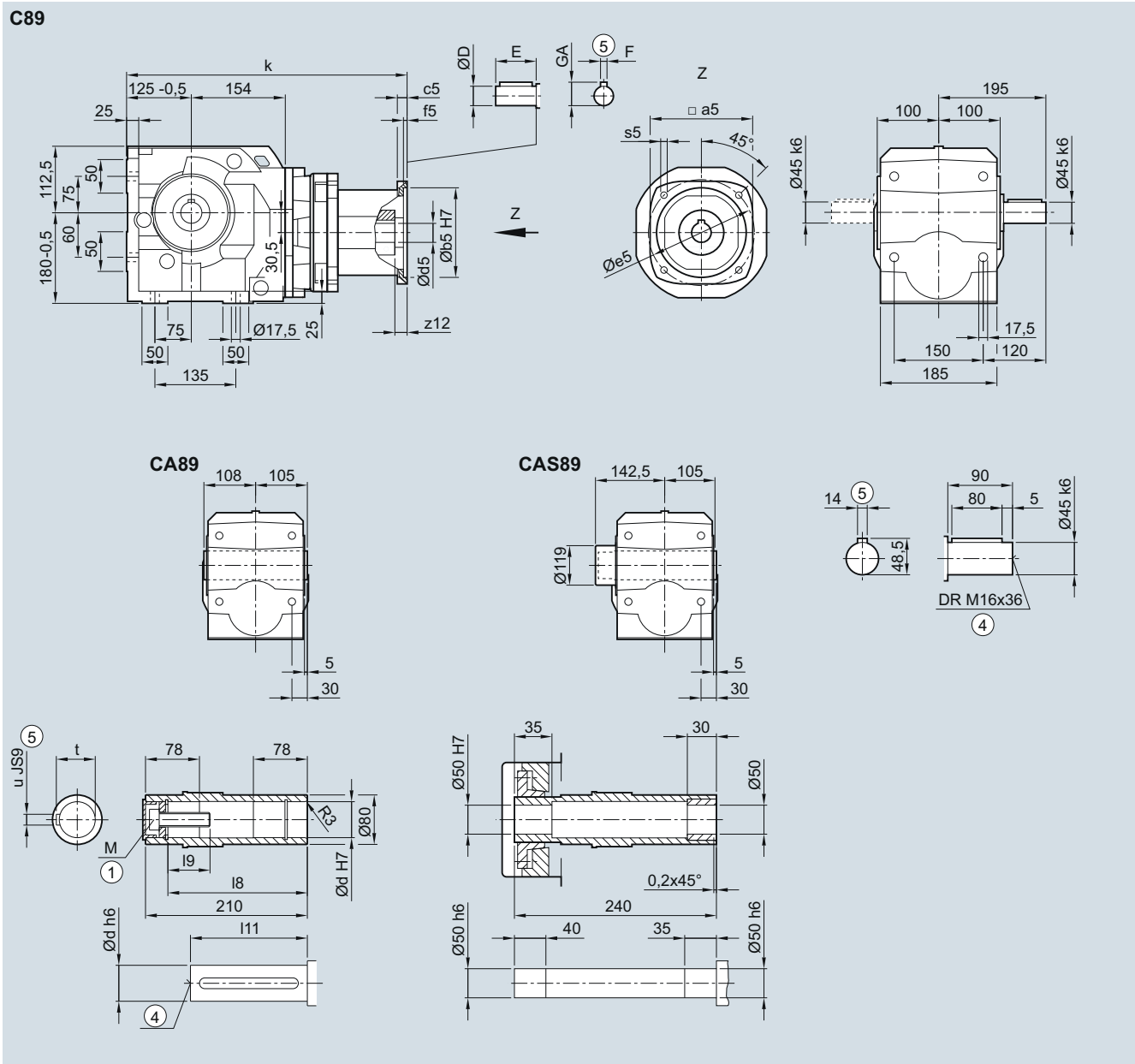

Adapter	a5	b5	c5	f5	e5	s5	z12	d5/D	E	F	GA	k
703	71.6	60	9	4.0	75	M5	18.0	14	30	5	16.0	367.0
704	96.5	80	10	4.0	100	M6	14.0	19	40	6	21.5	410.0
706	126.0	110	12	4.5	130	M8	15.0	24	50	8	27.0	423.0
708	155.0	130	15	4.5	165	M10	23.5	32	58	10	35.0	466.5
710	192.5	180	18	5.0	215	M12	33.0	38	80	10	41.0	535.5

① ISO 4014

④ DIN 332

⑤ Feather key/keyway DIN 6885

C.F.89 gearbox in a flange-mounted design

CF030KQ, CAF030KQ, CAFS030KQ

CF89

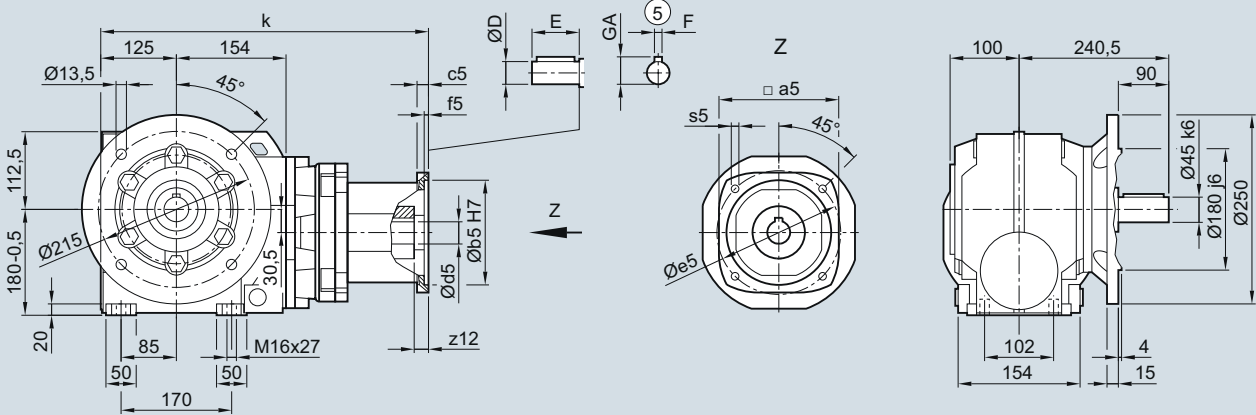

CAF89

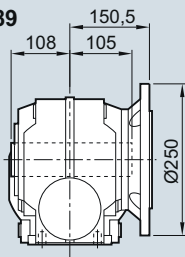

CAFS89

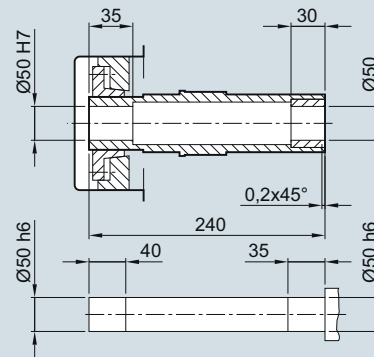
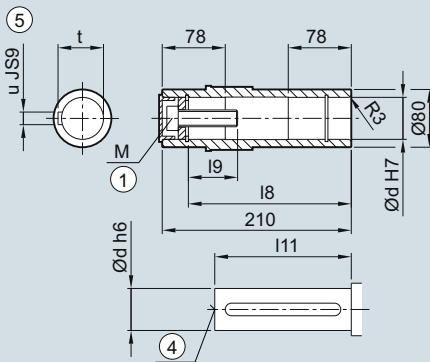
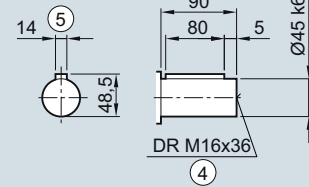
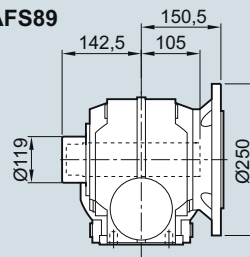

Adapter	a5	b5	c5	f5	e5	s5	z12	d5/D	E	F	GA	k
703	71.6	60	9	4.0	75	M5	18.0	14	30	5	16.0	367.0
704	96.5	80	10	4.0	100	M6	14.0	19	40	6	21.5	410.0
706	126.0	110	12	4.5	130	M8	15.0	24	50	8	27.0	423.0
708	155.0	130	15	4.5	165	M10	23.5	32	58	10	35.0	466.5
710	192.5	180	18	5.0	215	M12	33.0	38	80	10	41.0	535.5

① ISO 4014

④ DIN 332

⑤ Feather key/keyway DIN 6885

SIMOGEAR Gearboxes

Helical worm gearbox with adapter KQ

Dimensions

C.Z.89 gearbox in a housing flange design

CZ030KQ, CAZ030KQ, CAZS030KQ

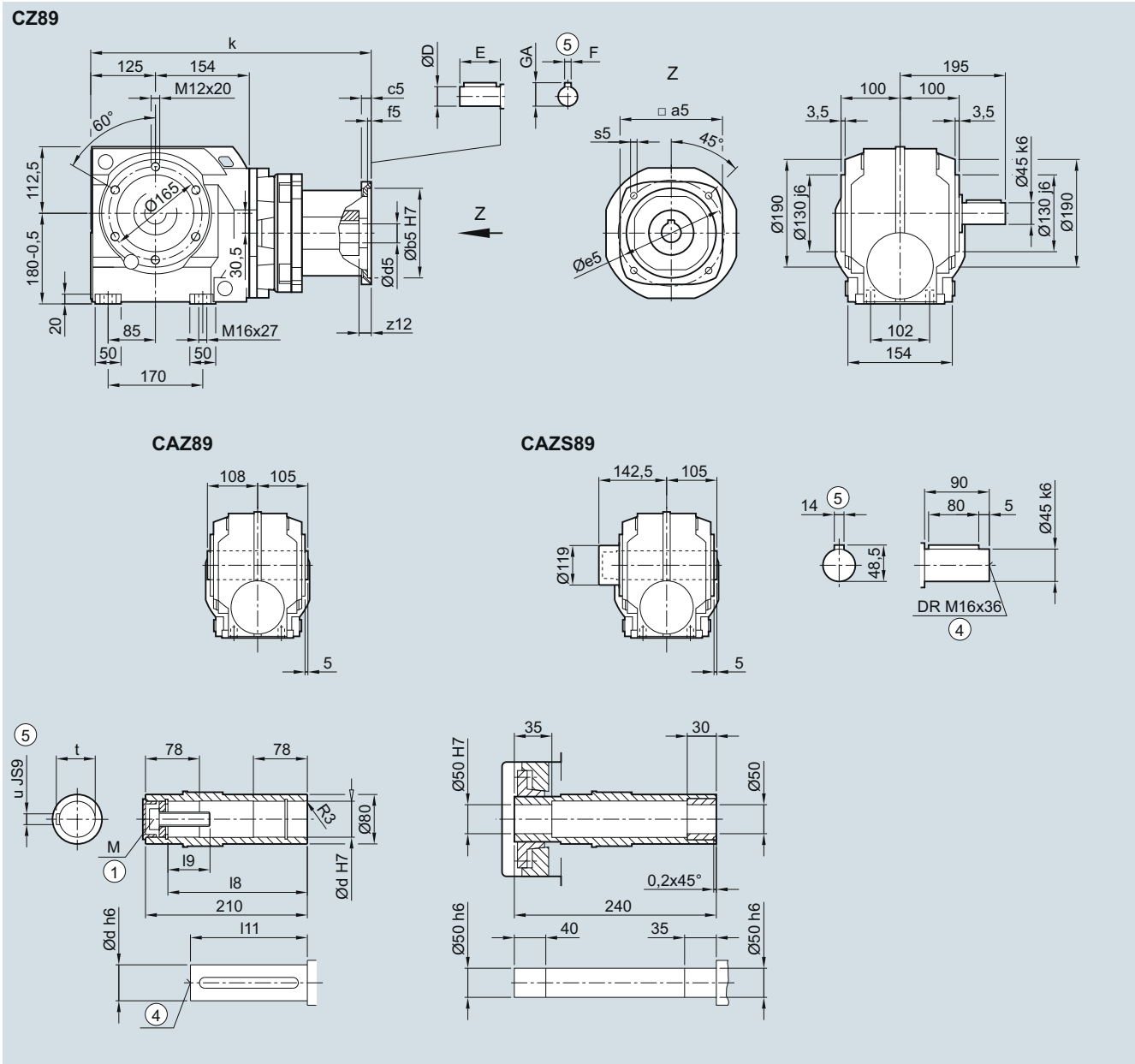

Adapter	a5	b5	c5	f5	e5	s5	z12	d5/D	E	F	GA	k
703	71.6	60	9	4.0	75	M5	18.0	14	30	5	16.0	367.0
704	96.5	80	10	4.0	100	M6	14.0	19	40	6	21.5	410.0
706	126.0	110	12	4.5	130	M8	15.0	24	50	8	27.0	423.0
708	155.0	130	15	4.5	165	M10	23.5	32	58	10	35.0	466.5
710	192.5	180	18	5.0	215	M12	33.0	38	80	10	41.0	535.5

① ISO 4014

④ DIN 332

⑤ Feather key/keyway DIN 6885

CAD.89 gearbox in a shaft-mounted design

CAD030KQ, CADS030KQ

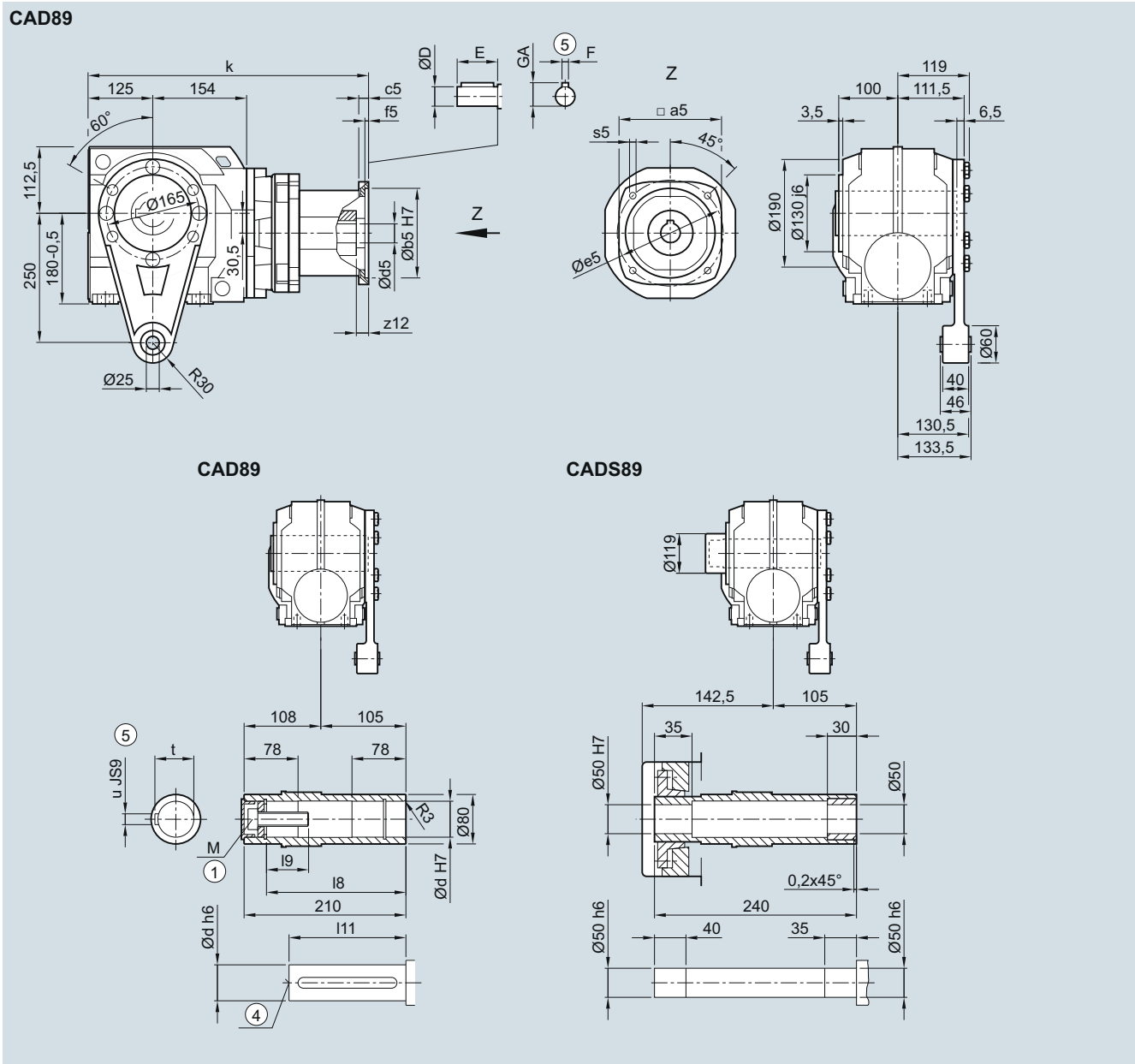

Adapter	a5	b5	c5	f5	e5	s5	z12	d5/D	E	F	GA	k
703	71.6	60	9	4.0	75	M5	18.0	14	30	5	16.0	367.0
704	96.5	80	10	4.0	100	M6	14.0	19	40	6	21.5	410.0
706	126.0	110	12	4.5	130	M8	15.0	24	50	8	27.0	423.0
708	155.0	130	15	4.5	165	M10	23.5	32	58	10	35.0	466.5
710	192.5	180	18	5.0	215	M12	33.0	38	80	10	41.0	535.5

① ISO 4014

④ DIN 332

⑤ Feather key/keyway DIN 6885

SIMOGEAR Gearboxes

Helical worm gearbox with adapter KQS

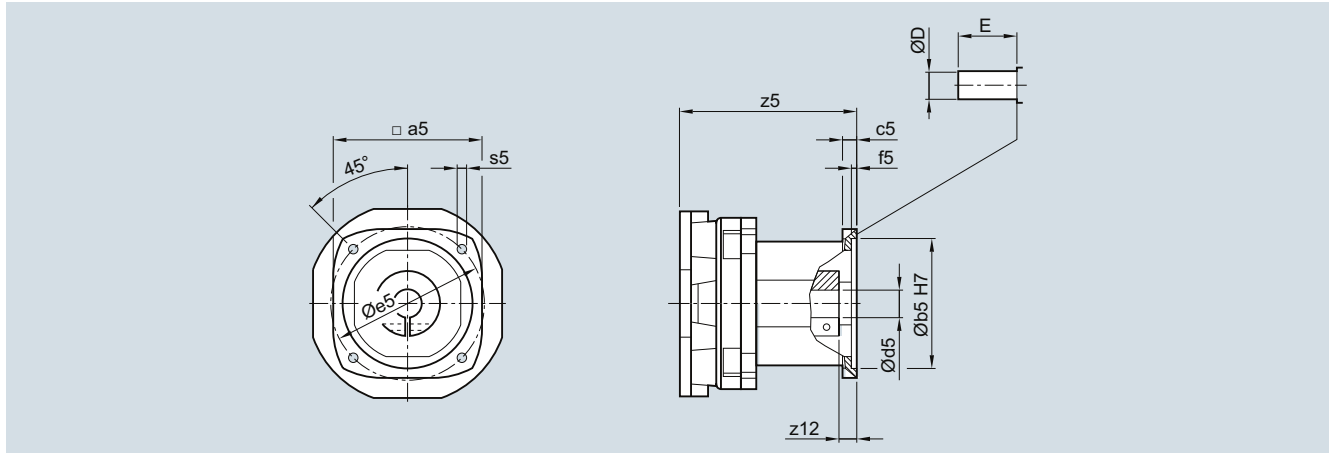
Dimensions**C...29 to C...89 gearboxes****C...030KQS, C.F.030KQS, C.Z.030KQS, C.D.030KQS**

6

Adapter	a5	b5	c5	f5	e5	s5	z12	d5/D	E	z5
C...29										
703	71.6	60	9	4.0	75	M5	18.0	14	30	99.5
704	96.5	80	10	4.0	100	M6	14.0	19	40	146.5
706	126.0	110	12	4.5	130	M8	15.0	24	50	159.5
C...39										
703	71.6	60	9	4.0	75	M5	18.0	14	30	99.5
704	96.5	80	10	4.0	100	M6	14.0	19	40	146.5
706	126.0	110	12	4.5	130	M8	15.0	24	50	159.5
C...49										
703	71.6	60	9	4.0	75	M5	18.0	14	30	90.0
704	96.5	80	10	4.0	100	M6	14.0	19	40	137.0
706	126.0	110	12	4.5	130	M8	15.0	24	50	150.0
708	155.0	130	15	4.5	165	M10	23.5	32	58	193.5
C...69										
703	71.6	60	9	4.0	75	M5	18.0	14	30	90.0
704	96.5	80	10	4.0	100	M6	14.0	19	40	137.0
706	126.0	110	12	4.5	130	M8	15.0	24	50	150.0
708	155.0	130	15	4.5	165	M10	23.5	32	58	193.5
710	192.5	180	15	5.0	215	M12	33.0	38	80	262.5
C...89										
704	96.5	80	10	4.0	100	M6	14.0	19	40	131.0
706	126.0	110	12	4.5	130	M8	15.0	24	50	144.0
708	155.0	130	15	4.5	165	M10	23.5	32	58	187.5
710	192.5	180	15	5.0	215	M12	33.0	38	80	256.5

C...49 to C...89 gearboxes

C...030K8, C.F.030K8, C.Z.030K8, C.D.030K8

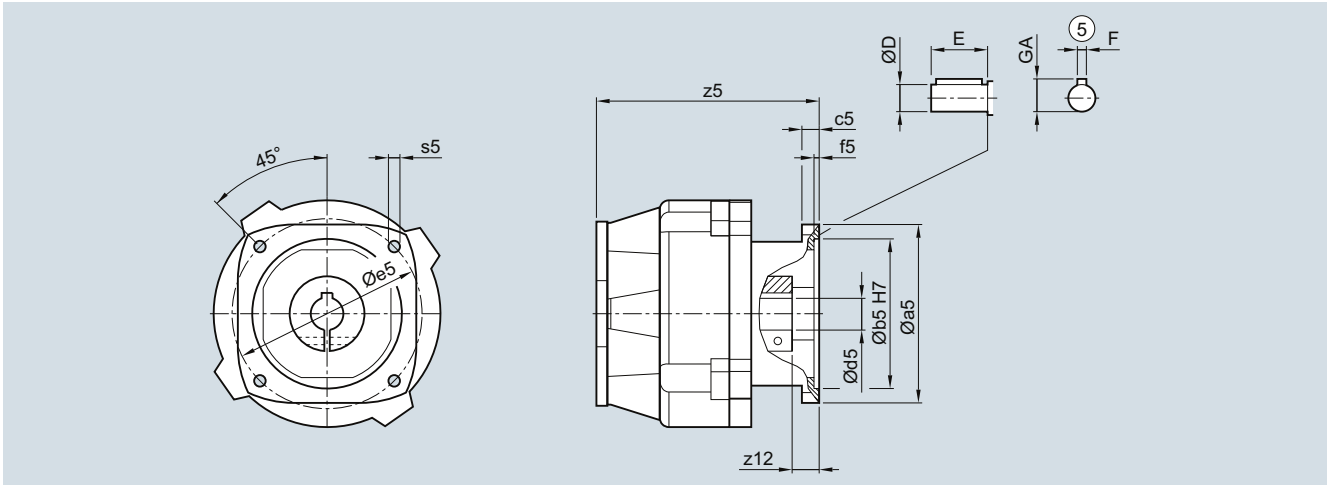

Adapter	a5	b5	c5	f5	e5	s5	z12	d5/D	E	F	GA	z5
C...49												
808	155.0	130	35	4.5	165	M10	43.5	32	80	10	35.0	213.5
C...69												
808	155.0	130	35	4.5	165	M10	43.5	32	80	10	35.0	213.5
810	192.5	180	15	5.0	215	M12	33.0	38	80	10	41.0	262.5
C...89												
808	155.0	130	35	4.5	165	M10	43.5	32	80	10	35.0	207.5
810	192.5	180	15	5.0	215	M12	33.0	38	80	10	41.0	256.5

⑤ Feather key/keyway DIN 6885

SIMOGEAR Gearboxes

Helical worm gearbox with adapter K5

Dimensions

C...29 to C...89 gearboxes

C..030K5, C.F.030K5, C.Z.030K5, C.D.030K5

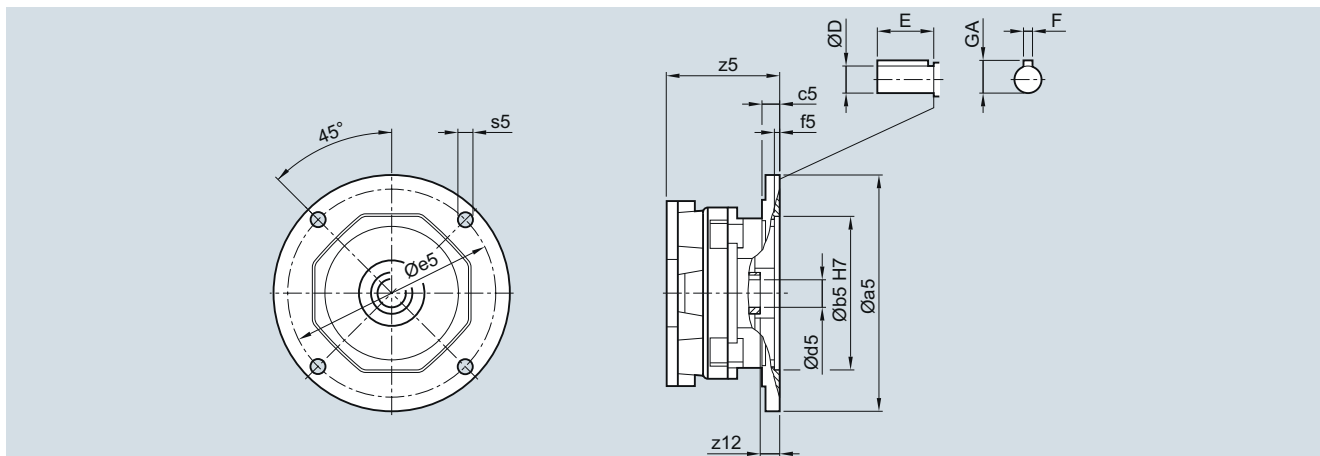

6

Adapter	a5	b5	c5	f5	e5	s5	z12	d5/D	E	F	GA	z5
C...29												
56	168	114.3	15	5.0	149.2	11.0	16	15.875	47.752	4.763	17.895	118.5
140	168	114.3	15	5.0	149.2	11.0	16	22.225	57.150	4.763	24.346	118.5
C...39												
56	168	114.3	15	5.0	149.2	11.0	16	15.875	47.752	4.763	17.895	118.5
140	168	114.3	15	5.0	149.2	11.0	16	22.225	57.150	4.763	24.346	118.5
180	226	215.9	22	5.5	184.1	13.5	26	28.575	69.850	6.350	31.394	200.5
C...49												
56	168	114.3	15	5.0	149.2	11.0	16	15.875	47.752	4.763	17.895	109.0
140	168	114.3	15	5.0	149.2	11.0	16	22.225	57.150	4.763	24.346	109.0
180	226	215.9	22	5.5	184.1	13.5	26	28.575	69.850	6.350	31.394	191.0
C...69												
56	168	114.3	15	5.0	149.2	11.0	16	15.875	47.752	4.763	17.895	109.0
140	168	114.3	15	5.0	149.2	11.0	16	22.225	57.150	4.763	24.346	109.0
180	226	215.9	22	5.5	184.1	13.5	26	28.575	69.850	6.350	31.394	191.0
210	226	215.9	22	5.5	184.1	13.5	12	34.925	85.850	7.938	38.443	207.0
C...89												
56	168	114.3	15	5.0	149.2	11.0	16	15.875	47.752	4.763	17.895	103.0
140	168	114.3	15	5.0	149.2	11.0	16	22.225	57.150	4.763	24.346	103.0
180	226	215.9	22	5.5	184.1	13.5	26	28.575	69.850	6.350	31.394	185.0
210	226	215.9	22	5.5	184.1	13.5	12	34.925	85.850	7.938	38.443	201.0

C...29 to C...89 gearboxes

C..030K3, C.F.030K3, C.Z.030K3, C.D.030K3

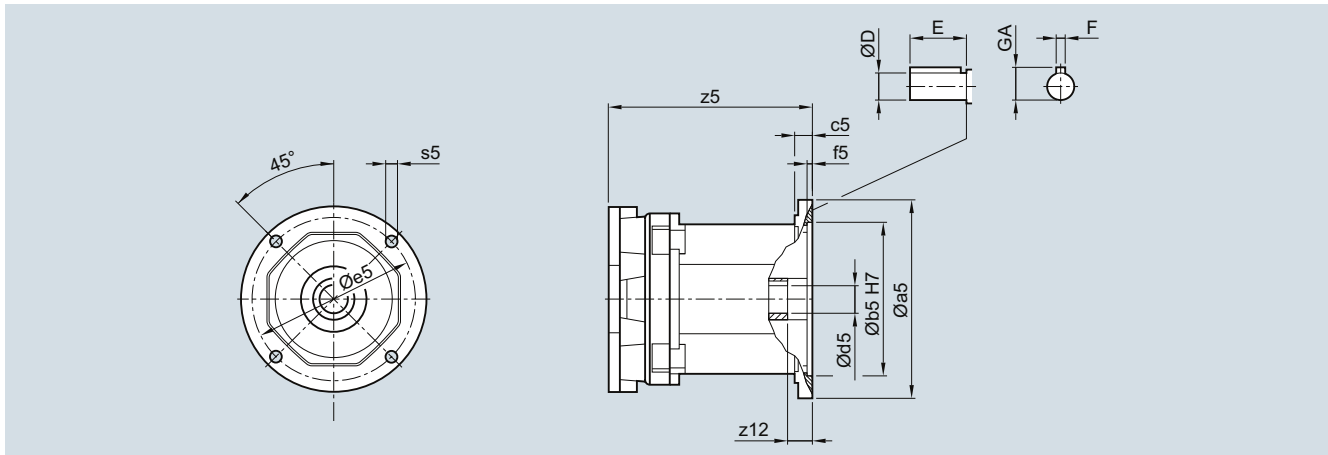

Adapter	a5	b5	c5	f5	e5	s5	z12	d5/D	E	GA	F	z5
C...29												
56	168	114.3	15	5.0	149.2	11.0	27.5	15.875	47.752	4.763	17.895	201.0
140	168	114.3	15	5.0	149.2	11.0	28.0	22.225	57.150	4.763	24.346	201.0
C...39												
56	168	114.3	15	5.0	149.2	11.0	27.5	15.875	47.752	4.763	17.895	201.0
140	168	114.3	15	5.0	149.2	11.0	28.0	22.225	57.150	4.763	24.346	201.0
180	226	215.9	22	5.5	184.1	13.5	42.0	28.575	69.850	6.350	31.394	257.0
C...49												
56	168	114.3	15	5.0	149.2	11.0	27.5	15.875	47.752	4.763	17.895	191.5
140	168	114.3	15	5.0	149.2	11.0	28.0	22.225	57.150	4.763	24.346	191.5
180	226	215.9	22	5.5	184.1	13.5	42.0	28.575	69.850	6.350	31.394	247.5
C...69												
56	168	114.3	15	5.0	149.2	11.0	27.5	15.875	47.752	4.763	17.895	191.5
140	168	114.3	15	5.0	149.2	11.0	28.0	22.225	57.150	4.763	24.346	191.5
180	226	215.9	22	5.5	184.1	13.5	42.0	28.575	69.850	6.350	31.394	247.5
210	226	215.9	22	5.5	184.1	13.5	49.5	34.925	85.850	7.938	38.443	318.0
C...89												
56	168	114.3	15	5.0	149.2	11.0	27.5	15.875	47.752	4.763	17.895	185.5
140	168	114.3	15	5.0	149.2	11.0	28.0	22.225	57.150	4.763	24.346	185.5
180	226	215.9	22	5.5	184.1	13.5	42.0	28.575	69.850	6.350	31.394	241.5
210	226	215.9	22	5.5	184.1	13.5	49.5	34.925	85.850	7.938	38.443	312.0

SIMOGEAR Gearboxes

Helical worm gearboxes

Dimensions**SIMOLOC assembly system**

CADR

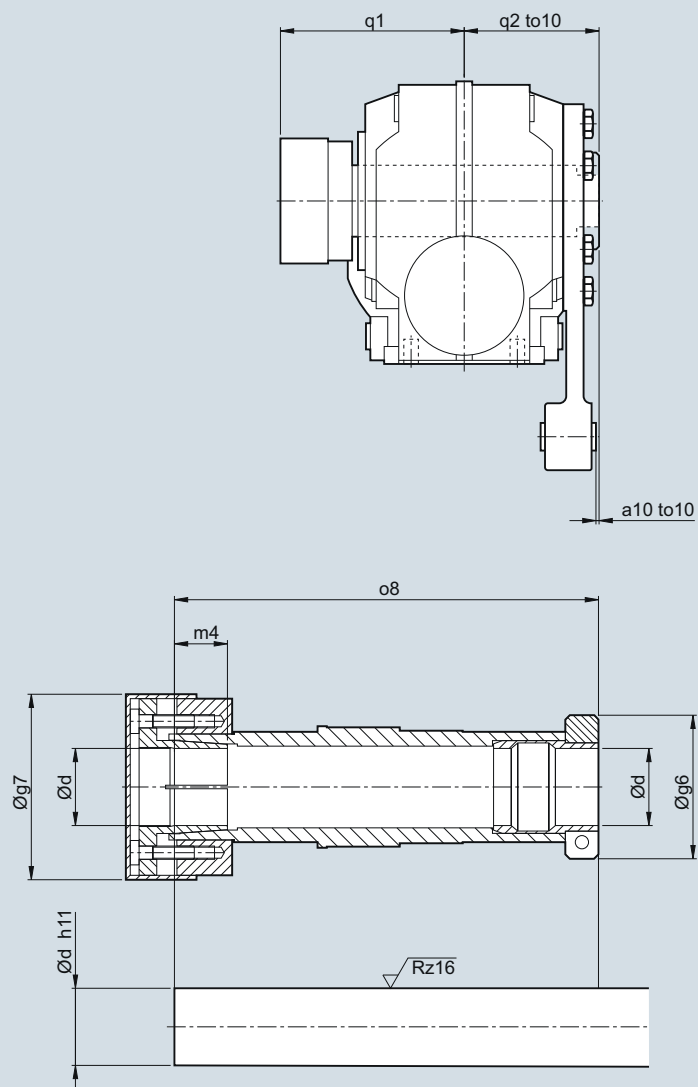

Note mounting tolerance to10 when positioning the torque arm.

SIMOLOC assembly system (continued)

d	g6	g7	m4	o8	q1	q2	a10	to10
CADR29								
20	58.5	56	18.5	151.0	102	75	11	+2.1
1"								+0.6
0.75"								
CADR39								
30	62.0	76	22	160.5	106	75	39	+2.2
25								+0.7
1.25"								
1.1875"								
1"								
CADR49								
35	65.0	84	24	192.0	124	90	35	+2.6
30								+0.8
1.4375"								
1.375"								
1.25"								
1.1875"								
CADR69								
40	79.5	94	30	217.5	138	102	39	+2.5
35								+0.7
1.5"								
1.4375"								
1.375"								
1.625"								
CADR89								
50	89.0	114	32	264.0	171	124	45	+3.4
40								+1.5
2"								
1.9375"								
1.75"								
1.625"								

SIMOGEAR Gearboxes

Helical worm gearboxes

Dimensions

Protection cover for hollow shaft

Protection cover for hollow shaft and hollow shaft with shrink disk

CAS, CAFS, CAZS, CADS

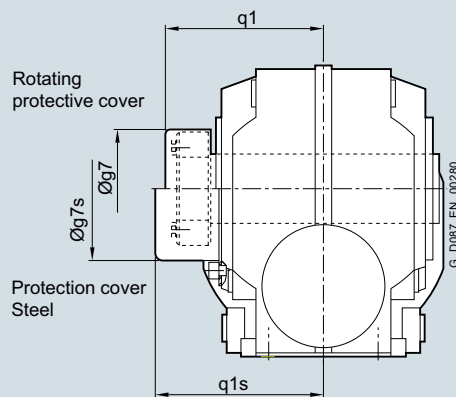

Gearbox type	CA..29	CA..39	CA..49	C..69	C..89
Rotating protective cover with shrink disk version					
g7	55	76.0	84	84	94.0
q1	85	89.5	107	115	125.5
Protection cover					
g7s	58	82.5	86	99	99.0
q1s	91	109.0	122	126	132.5

Protection cover for hollow shaft with SIMOLOC assembly system

CADR

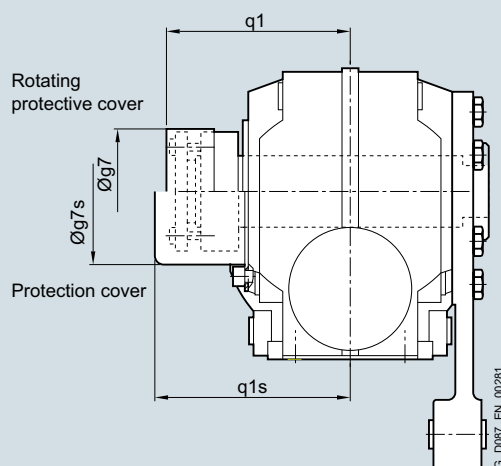

Gearbox type	CADR29	CADR39	CADR49	CADR69	CADR89
Rotating protective cover					
g7	56.0	76.0	84	94	114
q1	101.5	106.0	124	144	171
Protection cover					
g7s	58.0	82.5	86	99	137
q1s	104.5	109.0	127	147	174

Inner contour of the flange design

Notes regarding the design of the customer's interface.

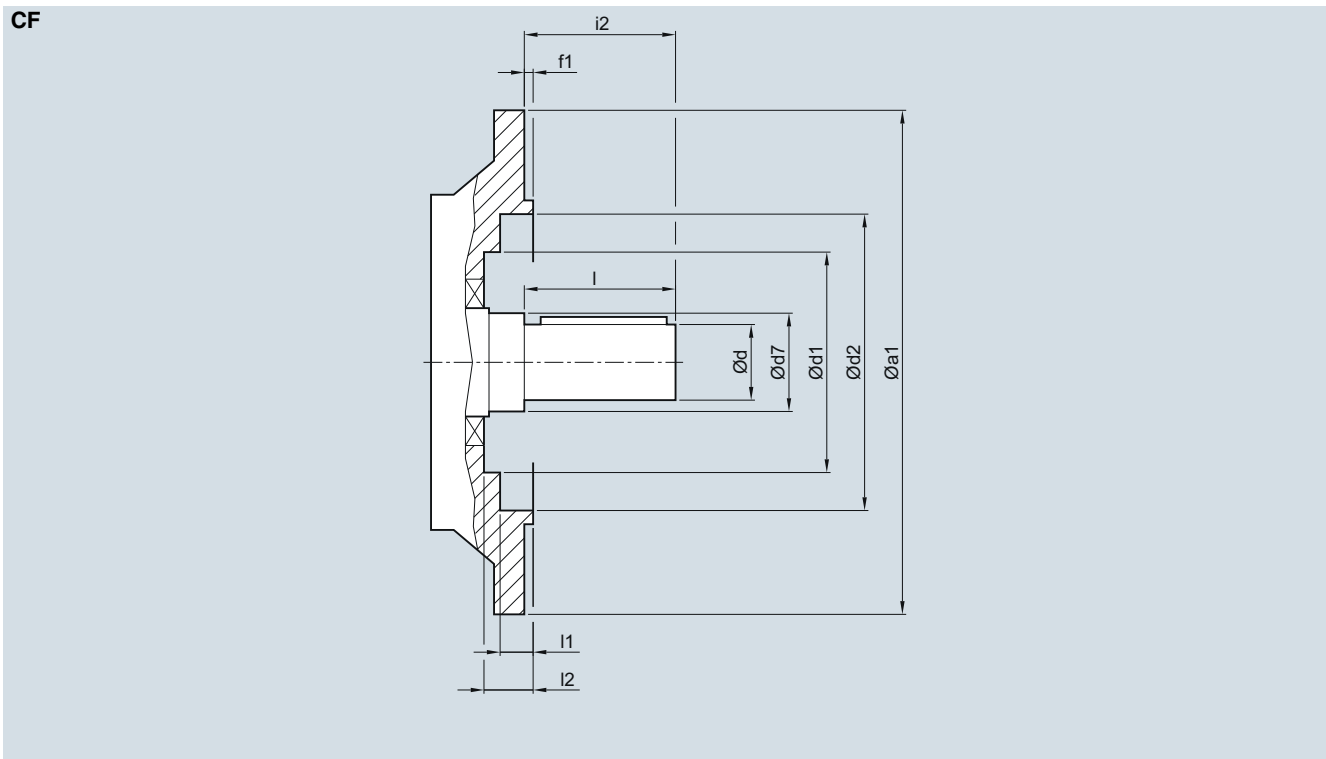

Gearbox type	a1	d	d7	d1	d2	f1	i2	l	l1	l2
CF29	120	20	40	-	70	3.0	40	40	24.0	-
	160			70	101	3.5			8.5	24.5
CF39	160	25	30	-	100	3.5	50	50	5.0	-
CF49	200	30	35	-	118	3.5	60	60	5.5	-
CF.69	200	35	45	105	120	4.0	70	70	4.5	48.0
CF.89	250	45	70	134	165	4.0	90	90	6.5	53.0

SIMOGEAR Gearboxes

Helical worm gearboxes

Dimensions

Inner contour of the flange design (continued)

Notes regarding the design of the customer's interface, e.g. plug-in shaft for hollow shaft design

CAF.

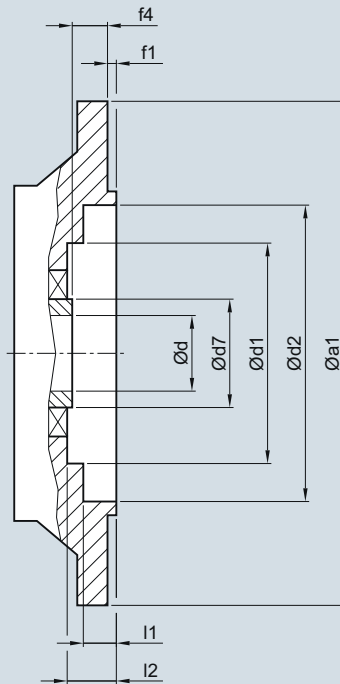

6

Gearbox type	a1	d	d7	d1	d2	f1	f4	l1	l2
CAF.29	120	20	35	-	70	3.0	23.0	24.0	-
	160			70	101	3.5		8.5	24.5
CAF.39	160	25/30	45	80	102	3.5	24.0	2.0	29.5
CAF.49	200	30/35	50	90	120	3.5	25.0	4.0	30.5
CAF.69	200	40/45	65	105	120	4.0	42.0	4.5	48.0
CAF.89	250	50/60	80	134	147	4	45.5	14.0	53.0

Worm gearboxes

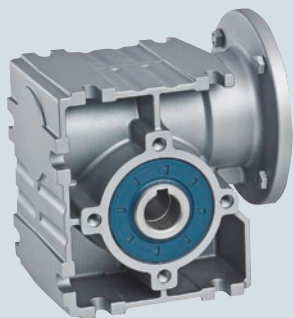

7/2	Orientation
7/3	Transmission ratios and torques
7/3	Selection and ordering data
7/5	General technical specifications
7/5	Permissible radial force
7/5	Dimensions
7/5	Dimensional drawing overview
7/6	S.09
7/7	S.F09
7/8	S.Z09
7/9	SAD09
7/10	S.19
7/11	S.F19
7/12	S.Z19
7/13	SAD09
7/14	S.29
7/15	S.F29
7/16	S.Z29
7/17	SAD29
7/18	Protection cover for hollow shaft

SIMOGEAR Gearboxes

Worm gearboxes

Orientation

SIMOGEAR worm gearbox S

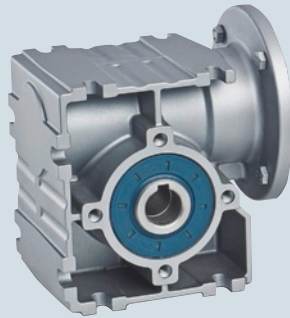

Fig. 7/1 Worm gearbox S

Gearbox designation	Number of sizes	Maximum output torque	Transmission ratio	Maximum motor power
		T_{2N} Nm	i -	P_1 kW
S09 ... S29 (1-stage)	3	33 ... 116	5.0 ... 100	0.55

SIMOGEAR helical worm geared motors are available in the following versions for mounting in any position:

- 1 stage
- Shaft-mounted design with torque arm SAD
- Flange design SF
- Design with integrated housing flange SZ
- Foot-mounted design S
- Solid shaft design with feather key (at one end or both ends) S
- Hollow-shaft design with feather key SA
- Hollow-shaft design with plug-in shaft SE

For helical worm gearboxes, the torque arm is supplied loose to enable it to be mounted as required on site. The position of the torque arm can be freely selected.

Selection and ordering data

i	Lead angle of the worm γ_m	$n_{mot} = 2\ 800\ rpm$				$n_{mot} = 1\ 400\ rpm$				Adapter				Article No.
		n_2 rpm	T_{2N} Nm	P_{mot} kW	η %	n_2 rpm	T_{2N} Nm	P_{mot} kW	η %	K4	63	71	80	
S.09														
80	2.1	35.0	18	0.14	48	17.5	19	0.07	47	✓				2KJ3730 - ■■■ A04 - 0 ■ B1
60	2.7	46.7	22	0.20	55	23.3	24	0.11	52	✓				2KJ3730 - ■■■ A04 - 0 ■ C1
50	3.2	56.0	21	0.21	58	28.0	27	0.14	56	✓				2KJ3730 - ■■■ A04 - 0 ■ D1
40	3.8	70.0	21	0.24	63	35.0	28	0.17	61	✓				2KJ3730 - ■■■ A04 - 0 ■ E1
30	4.6	93.3	20	0.29	68	46.7	28	0.20	67	✓				2KJ3730 - ■■■ A04 - 0 ■ F1
25	5.2	112.0	20	0.33	72	56.0	27	0.23	70	✓				2KJ3730 - ■■■ A04 - 0 ■ G1
20	7.4	140.0	21	0.40	77	70.0	27	0.26	75	✓				2KJ3730 - ■■■ A04 - 0 ■ H1
15	9.2	186.7	20	0.48	81	93.3	27	0.33	80	✓				2KJ3730 - ■■■ A04 - 0 ■ J1
10	14.0	280.0	20	0.68	86	140.0	27	0.47	85	✓				2KJ3730 - ■■■ A04 - 0 ■ K1
7	19.0	400.0	19	0.89	89	200.0	26	0.62	88	✓				2KJ3730 - ■■■ A04 - 0 ■ L1
5	25.0	560.0	19	1.22	91	280.0	25	0.81	91	✓				2KJ3730 - ■■■ A04 - 0 ■ M1
S.19														
80	3.5	35.0	33	0.22	55	17.5	35	0.12	54	✓				2KJ3731 - ■■■ A04 - 0 ■ B1
60	3.5	46.7	33	0.26	61	23.3	44	0.18	59	✓				2KJ3731 - ■■■ A04 - 0 ■ C1
50	4.0	56.0	33	0.30	64	28.0	44	0.20	63	✓	✓			2KJ3731 - ■■■ A04 - 0 ■ D1
40	4.5	70.0	31	0.33	68	35.0	43	0.24	67	✓	✓			2KJ3731 - ■■■ A04 - 0 ■ E1
30	5.5	93.3	31	0.42	73	46.7	41	0.28	72	✓	✓			2KJ3731 - ■■■ A04 - 0 ■ F1
25	6.5	112.0	31	0.48	76	56.0	41	0.32	75	✓	✓			2KJ3731 - ■■■ A04 - 0 ■ G1
20	9.5	140.0	31	0.56	81	70.0	41	0.38	80	✓	✓			2KJ3731 - ■■■ A04 - 0 ■ H1
15	11.0	186.7	30	0.70	84	93.3	41	0.48	84	✓	✓			2KJ3731 - ■■■ A04 - 0 ■ J1
10	17.0	280.0	30	1.00	88	140.0	40	0.67	88	✓	✓			2KJ3731 - ■■■ A04 - 0 ■ K1
7	17.0	400.0	29	1.33	91	200.0	39	0.91	90	✓	✓			2KJ3731 - ■■■ A04 - 0 ■ L1
5	23.0	560.0	28	1.78	92	280.0	37	1.18	92	✓	✓			2KJ3731 - ■■■ A04 - 0 ■ M1
S.29														
100	2.0	28.0	57	0.33	50	14.0	72	0.22	49	✓				2KJ3732 - ■■■ A04 - 0 ■ A1
80	2.5	35.0	57	0.39	54	17.5	80	0.27	54	✓	✓			2KJ3732 - ■■■ A04 - 0 ■ B1
60	3.0	46.7	57	0.46	60	23.3	78	0.32	59	✓	✓			2KJ3732 - ■■■ A04 - 0 ■ C1
50	3.5	56.0	55	0.50	64	28.0	75	0.35	63	✓	✓			2KJ3732 - ■■■ A04 - 0 ■ D1
40	4.5	70.0	55	0.59	68	35.0	74	0.40	68	✓	✓			2KJ3732 - ■■■ A04 - 0 ■ E1
30	5.0	93.3	53	0.71	73	46.7	73	0.49	73	✓	✓	✓		2KJ3732 - ■■■ A04 - 0 ■ F1
25	6.0	112.0	53	0.82	76	56.0	73	0.56	76	✓	✓	✓		2KJ3732 - ■■■ A04 - 0 ■ G1
20	8.5	140.0	53	0.96	81	70.0	73	0.67	80	✓	✓	✓		2KJ3732 - ■■■ A04 - 0 ■ H1
15	10.0	186.7	53	1.23	84	93.3	72	0.84	84	✓	✓	✓		2KJ3732 - ■■■ A04 - 0 ■ J1
10	15.0	280.0	53	1.77	88	140.0	72	1.20	88	✓	✓	✓		2KJ3732 - ■■■ A04 - 0 ■ K1
7	15.0	400.0	53	2.44	91	200.0	71	1.63	91	✓	✓	✓		2KJ3732 - ■■■ A04 - 0 ■ L1
5	21.0	560.0	51	3.22	93	280.0	69	2.18	93	✓	✓	✓		2KJ3732 - ■■■ A04 - 0 ■ M1

Article No. supplement

Shaft design → Page 9/39

1 or 9

Adapter size

K4 B C D

Gearbox mounting type → Page 9/34

A, D, F or H

SIMOGEAR Gearboxes

Worm gearboxes

Transmission ratios and torques

Selection and ordering data

i	Lead angle of the worm γ_m	$n_{mot} = 900 \text{ rpm}$				$n_{mot} = 500 \text{ rpm}$				Adapter				Article No.
		n_2 rpm	T_{2N} Nm	P_{mot} kW	η %	n_2 rpm	T_{2N} Nm	P_{mot} kW	η %	K4	63	71	80	
S.09														
80	2.1	11.3	19	0.05	44	6.3	20	0.03	40	✓				2KJ3730 - ■ ■ ■ A04 - 0 ■ ■ B1
60	2.7	15.0	24	0.08	50	8.3	24	0.05	45	✓				2KJ3730 - ■ ■ ■ A04 - 0 ■ ■ C1
50	3.2	18.0	27	0.10	53	10.0	28	0.06	49	✓				2KJ3730 - ■ ■ ■ A04 - 0 ■ ■ D1
40	3.8	22.5	31	0.13	58	12.5	31	0.08	54	✓				2KJ3730 - ■ ■ ■ A04 - 0 ■ ■ E1
30	4.6	30.0	32	0.16	64	16.7	33	0.10	60	✓				2KJ3730 - ■ ■ ■ A04 - 0 ■ ■ F1
25	5.2	36.0	32	0.18	68	20.0	32	0.10	64	✓				2KJ3730 - ■ ■ ■ A04 - 0 ■ ■ G1
20	7.4	45.0	31	0.20	73	25.0	31	0.12	70	✓				2KJ3730 - ■ ■ ■ A04 - 0 ■ ■ H1
15	9.2	60.0	33	0.27	78	33.3	33	0.15	75	✓				2KJ3730 - ■ ■ ■ A04 - 0 ■ ■ J1
10	14.0	90.0	32	0.36	84	50.0	33	0.21	81	✓				2KJ3730 - ■ ■ ■ A04 - 0 ■ ■ K1
7	19.0	128.6	31	0.48	87	71.4	33	0.29	85	✓				2KJ3730 - ■ ■ ■ A04 - 0 ■ ■ L1
5	25.0	180.0	30	0.63	90	100.0	33	0.39	88	✓				2KJ3730 - ■ ■ ■ A04 - 0 ■ ■ M1
S.19														
80	3.5	11.3	35	0.08	51	6.3	36	0.05	47	✓				2KJ3731 - ■ ■ ■ A04 - 0 ■ ■ B1
60	3.5	15.0	49	0.14	57	8.3	51	0.09	52	✓				2KJ3731 - ■ ■ ■ A04 - 0 ■ ■ C1
50	4.0	18.0	51	0.16	61	10.0	59	0.11	56	✓	✓			2KJ3731 - ■ ■ ■ A04 - 0 ■ ■ D1
40	4.5	22.5	51	0.18	65	12.5	64	0.14	61	✓	✓			2KJ3731 - ■ ■ ■ A04 - 0 ■ ■ E1
30	5.5	30.0	50	0.22	70	16.7	63	0.17	66	✓	✓			2KJ3731 - ■ ■ ■ A04 - 0 ■ ■ F1
25	6.5	36.0	49	0.25	74	20.0	62	0.19	70	✓	✓			2KJ3731 - ■ ■ ■ A04 - 0 ■ ■ G1
20	9.5	45.0	50	0.30	78	25.0	62	0.22	75	✓	✓			2KJ3731 - ■ ■ ■ A04 - 0 ■ ■ H1
15	11.0	60.0	50	0.38	82	33.3	62	0.27	79	✓	✓			2KJ3731 - ■ ■ ■ A04 - 0 ■ ■ J1
10	17.0	90.0	49	0.53	87	50.0	61	0.38	85	✓	✓			2KJ3731 - ■ ■ ■ A04 - 0 ■ ■ K1
7	17.0	128.6	47	0.70	90	71.4	58	0.49	88	✓	✓			2KJ3731 - ■ ■ ■ A04 - 0 ■ ■ L1
5	23.0	180.0	44	0.91	91	100.0	56	0.65	90	✓	✓			2KJ3731 - ■ ■ ■ A04 - 0 ■ ■ M1
S.29														
100	2.0	9.0	72	0.14	47	5.0	72	0.09	43	✓				2KJ3732 - ■ ■ ■ A04 - 0 ■ ■ A1
80	2.5	11.3	92	0.21	52	6.3	93	0.13	48	✓	✓			2KJ3732 - ■ ■ ■ A04 - 0 ■ ■ B1
60	3.0	15.0	93	0.26	57	8.3	116	0.19	53	✓	✓			2KJ3732 - ■ ■ ■ A04 - 0 ■ ■ C1
50	3.5	18.0	90	0.28	61	10.0	115	0.21	57	✓	✓			2KJ3732 - ■ ■ ■ A04 - 0 ■ ■ D1
40	4.5	22.5	90	0.32	66	12.5	113	0.24	62	✓	✓			2KJ3732 - ■ ■ ■ A04 - 0 ■ ■ E1
30	5.0	30.0	86	0.38	72	16.7	110	0.28	68	✓	✓	✓		2KJ3732 - ■ ■ ■ A04 - 0 ■ ■ F1
25	6.0	36.0	85	0.43	75	20.0	109	0.32	71	✓	✓	✓		2KJ3732 - ■ ■ ■ A04 - 0 ■ ■ G1
20	8.5	45.0	85	0.51	79	25.0	109	0.38	76	✓	✓	✓		2KJ3732 - ■ ■ ■ A04 - 0 ■ ■ H1
15	10.0	60.0	85	0.64	83	33.3	109	0.47	81	✓	✓	✓		2KJ3732 - ■ ■ ■ A04 - 0 ■ ■ J1
10	15.0	90.0	85	0.92	87	50.0	109	0.66	86	✓	✓	✓		2KJ3732 - ■ ■ ■ A04 - 0 ■ ■ K1
7	15.0	128.6	84	1.26	90	71.4	107	0.90	89	✓	✓	✓		2KJ3732 - ■ ■ ■ A04 - 0 ■ ■ L1
5	21.0	180.0	82	1.68	92	100.0	105	1.21	91	✓	✓	✓		2KJ3732 - ■ ■ ■ A04 - 0 ■ ■ M1

Article No. supplement

Shaft design → Page 9/39

1 or 9

Adapter size

K4 B C D

Gearbox mounting type → Page 9/34

A, D, F or H

Permissible radial force F_{Rperm}

Gearbox type	d mm	l mm	y mm	z mm	a kNmm	F_{Rperm} in N with $x = l/2$ for output speeds n_2 in rpm							
						≤ 16	≤ 25	≤ 40	≤ 63	≤ 100	≤ 160	≤ 250	≤ 400
S09	16	40	83.5	63.5	36 000	1 800	1 800	1 800	1 800	1 800	1 690	1 400	1 120
SF09			106.0	86.0		1 800	1 800	1 800	1 800	1 620	1 330	1 100	880
S19	20	40	98.0	78.0	76 000	3 800	3 800	3 800	3 200	2 650	2 180	1 780	1 420
SF19			128.0	108.0		3 200	3 120	2 920	2 450	2 030	1 670	1 360	1 090
S29	20	40	120.5	100.5	72 000	3 600	3 600	3 600	3 600	3 600	3 290	2 680	2 120
SF29			153.5	133.5		3 600	3 600	3 600	3 600	3 150	2 580	2 110	1 660

Dimensions
Dimensional drawing overview

 Information about dimensional drawings can be found in Chapter [Introduction on page 1/20](#).

Version	Size	Dimensional drawing on page
---------	------	-----------------------------

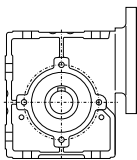
Foot-mounted design

S.09	7/6
S.19	7/10
S.29	7/14

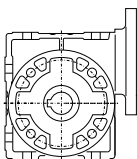
Flange-mounted design

S.F09	7/7
S.F19	7/11
S.F29	7/15

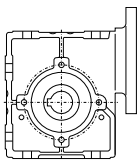
Housing flange design

S.Z09	7/8
S.Z19	7/12
S.Z29	7/16

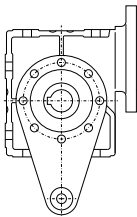
Shaft-mounted design

SAD09	7/9
SAD19	7/13
SAD29	7/17

Additional versions and options

Protection cover for hollow shafts	7/18
------------------------------------	------

S.F09 gearbox in a flange-mounted design

SF030, SAF030, SEF030

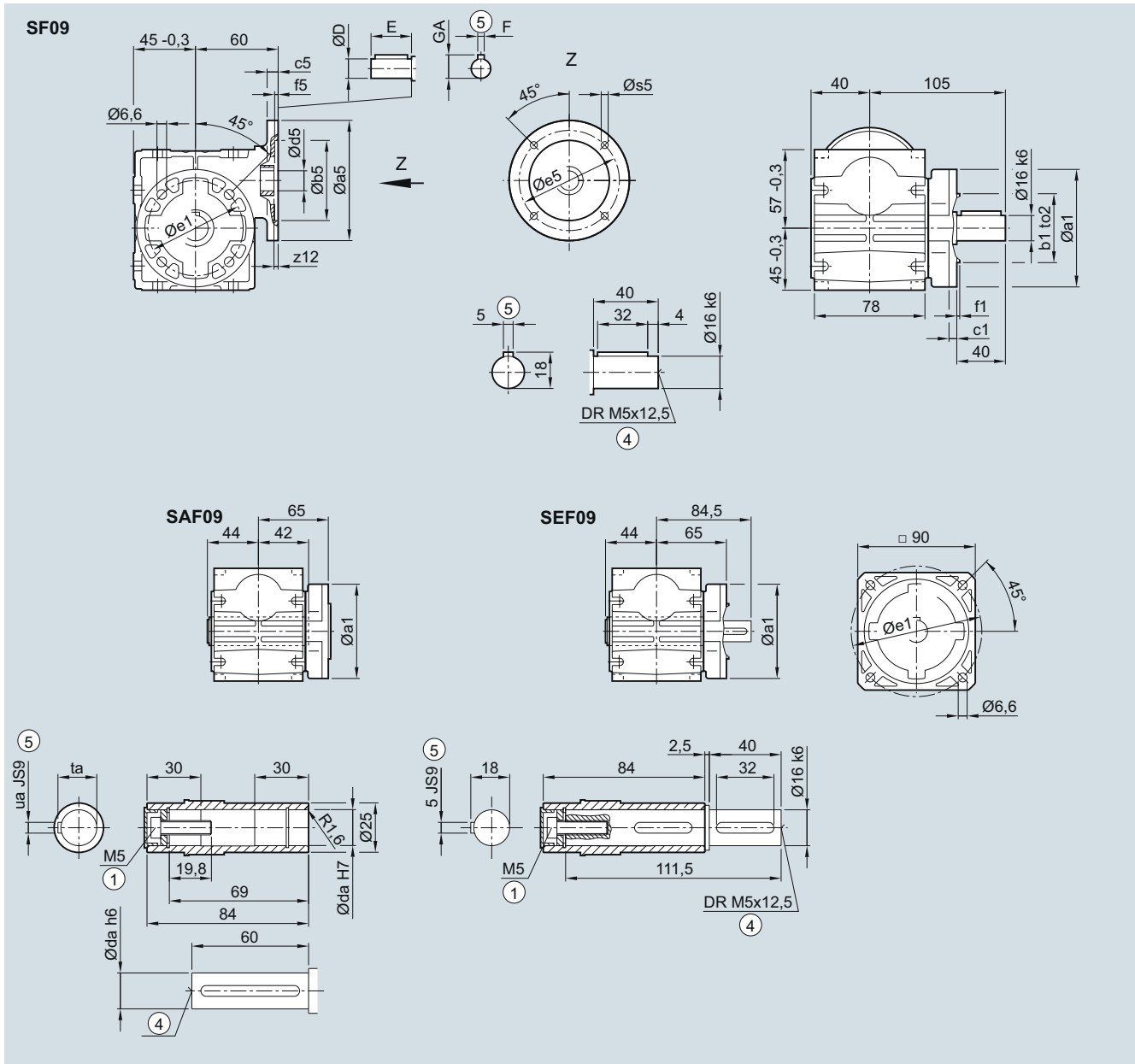

Hollow shaft	da	ua	ta
	14	5	16.3
	16	5	18.3

Flange	a1	e1	b1	to2	c1	f1
	80	65	50	j6	7	2.5
	120	100	80	j6	7	3.0

Adapter	a5	b5	c5	f5	e5	s5	z12	d5/D	E	F	GA
63	90	60	7	3	75	5.8	2	11	23	4	12.5

① ISO 4014

④ DIN 332

⑤ Feather key/keyway DIN 6885

SIMOGEAR Gearboxes

Worm gearbox with adapter K4

Dimensions

S.Z09 gearbox in a housing flange design

SZ030, SAZ030, SEZ030

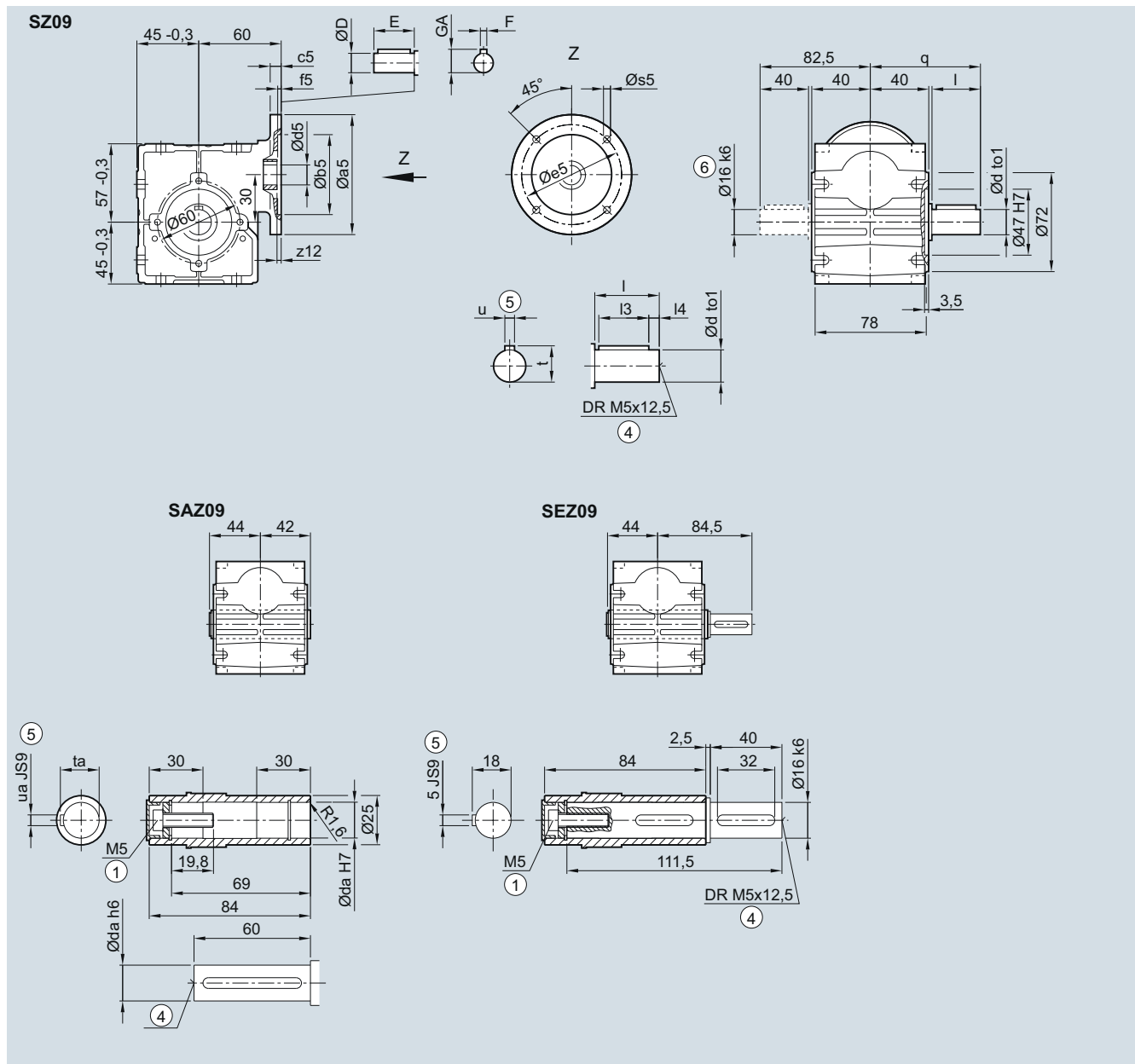

Solid shaft	d	to1	l	l3	l4	u	t	q	Hollow shaft		
									da	ua	ta
	14	k6	30	22	4	5	16	72.5	14	5	16.3
	16	k6	40	32	4	5	18	82.5	16	5	18.3

Adapter	a5	b5	c5	f5	e5	s5	z12	d5/D	E	F	GA
63	90	60	7	3	75	5.8	2	11	23	4	12.5

① ISO 4014

④ DIN 332

⑤ Feather key/keyway DIN 6885

⑥ Solid shaft with 2nd shaft extension only d16

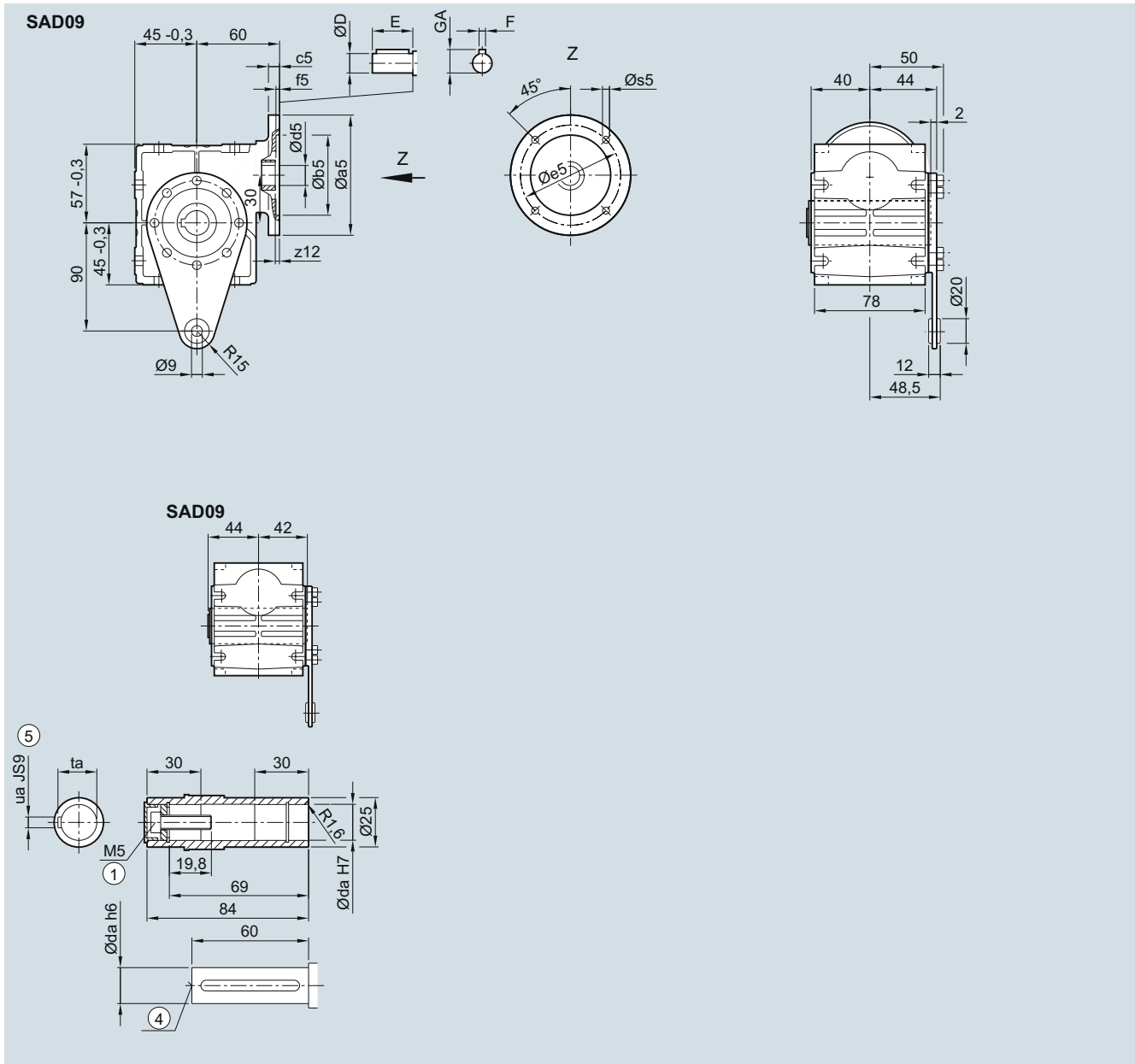
SAD09 gearbox in a shaft-mounted design
SAD030

Hollow shaft	da	ua	ta
	14	5	16.3
	16	5	18.3

Adapter	a5	b5	c5	f5	e5	s5	z12	d5/D	E	F	GA
63	90	60	7	3	75	5.8	2	11	23	4	12.5

① ISO 4014

④ DIN 332

⑤ Feather key/keyway DIN 6885

SIMOGEAR Gearboxes

Worm gearbox with adapter K4

Dimensions

S.19 gearbox in a foot-mounted design

S030, SA030, SE030

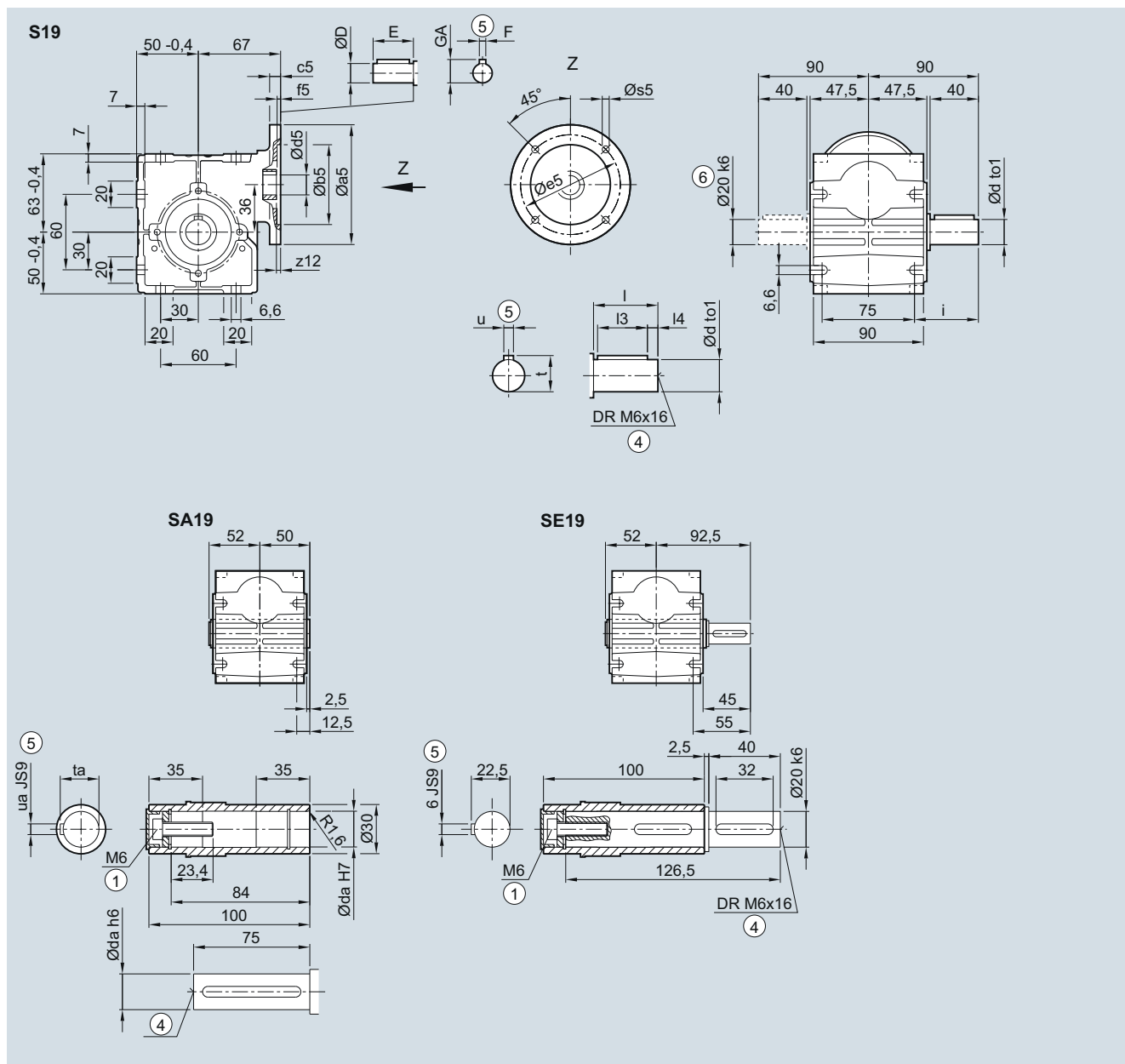

Solid shaft	d	to1	l	l3	l4	i	u	t	Hollow shaft	da	ua	ta
	18	k6	40	32	4	52.5	6	20.5		18	6	20.8
	20	k6	40	32	4	52.5	6	22.5		20	6	22.8
Adapter	a5	b5	c5	f5	e5	s5	z12	d5/D	E	F	GA	
63	90	60	7	3	75	5.8	2	11	23	4	12.5	
71	105	70	7	3	85	7.0	2	14	30	5	16.0	

① ISO 4014

④ DIN 332

⑤ Feather key/keyway DIN 6885

⑥ Solid shaft with 2nd shaft extension only d20

S.F19 gearbox in a flange-mounted design

SF030, SAF030, SEF030

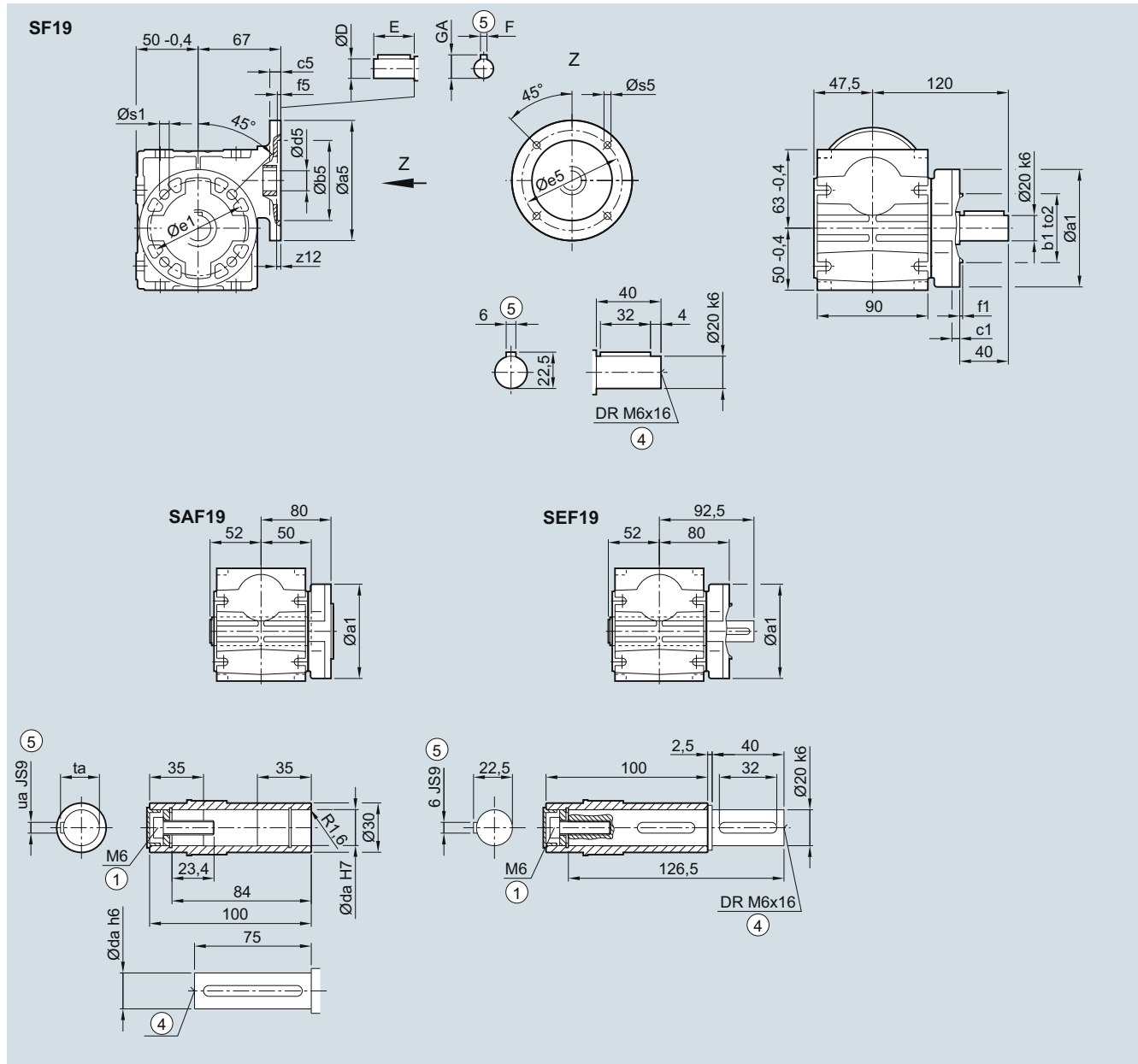

Hollow shaft	da	ua	ta
	18	6	20.8
	20	6	22.8

Flange	a1	e1	b1	to2	c1	f1	s1
	110	87	60	H8	8	4.0	9
	120	100	80	j6	8	3.0	6.6

Adapter	a5	b5	c5	f5	e5	s5	z12	d5/D	E	F	GA
63	90	60	7	3	75	5.8	2	11	23	4	12.5
71	105	70	7	3	85	7.0	2	14	30	5	16.0

① ISO 4014

④ DIN 332

⑤ Feather key/keyway DIN 6885

SIMOGEAR Gearboxes

Worm gearbox with adapter K4

Dimensions

S.Z19 gearbox in a housing flange design

SZ030, SAZ030, SEZ030

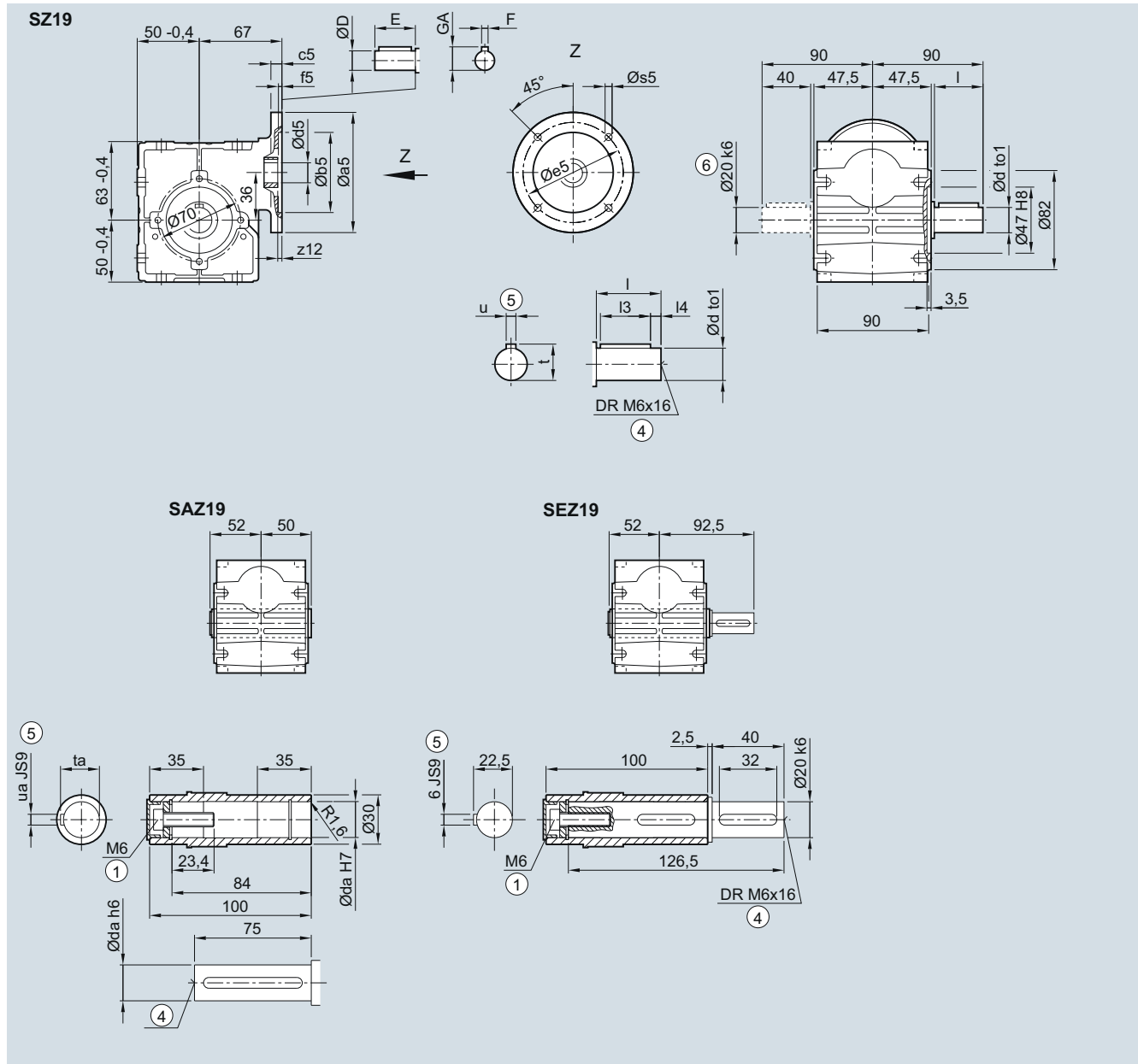

Solid shaft	d	to1	l	l3	l4	u	t	Hollow shaft	da	ua	ta
		18	k6	40	31	4	6		20.5		18
	20	k6	40	32	4	6	22.5		20	6	22.8
Adapter	a5	b5	c5	f5	e5	s5	z12	d5/D	E	F	GA
63	90	60	7	3	75	5.8	2	11	23	4	12.5
71	105	70	7	3	85	7.0	2	14	30	5	16.0

① ISO 4014

④ DIN 332

⑤ Feather key/keyway DIN 6885

⑥ Solid shaft with 2nd shaft extension only d20

SAD19 gearbox in a shaft-mounted design

SAD030

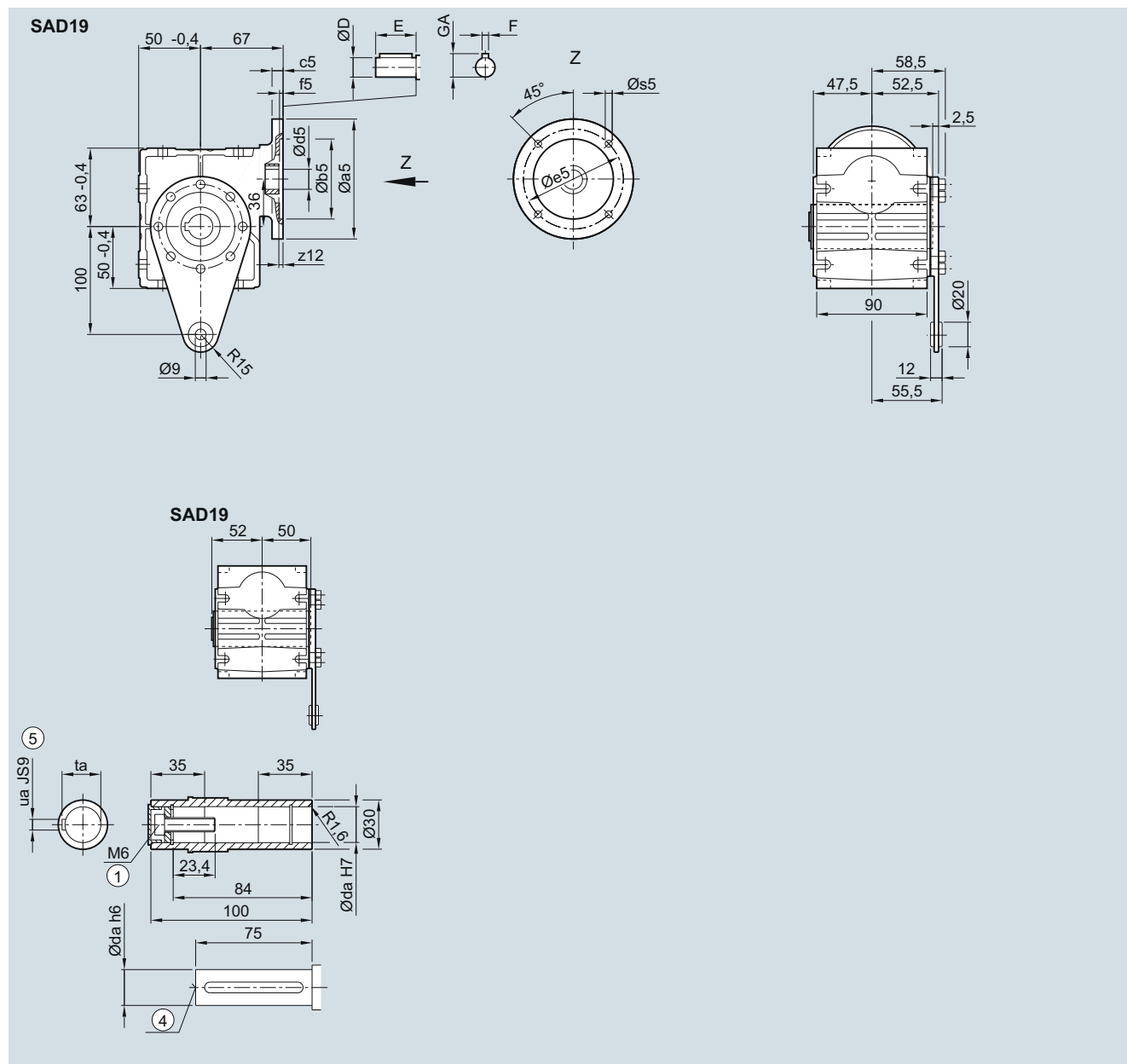

Hollow shaft	da	ua	ta
	18	6	20.8
	20	6	22.8

Adapter	a5	b5	c5	f5	e5	s5	z12	d5/D	E	F	GA
63	90	60	7	3	75	5.8	2	11	23	4	12.5
71	105	70	7	3	85	7.0	2	14	30	5	16.0

① ISO 4014

④ DIN 332

⑤ Feather key/keyway DIN 6885

SIMOGEAR Gearboxes

Worm gearbox with adapter K4

Dimensions

S.29 gearbox in a foot-mounted design

S030, SA030, SE030

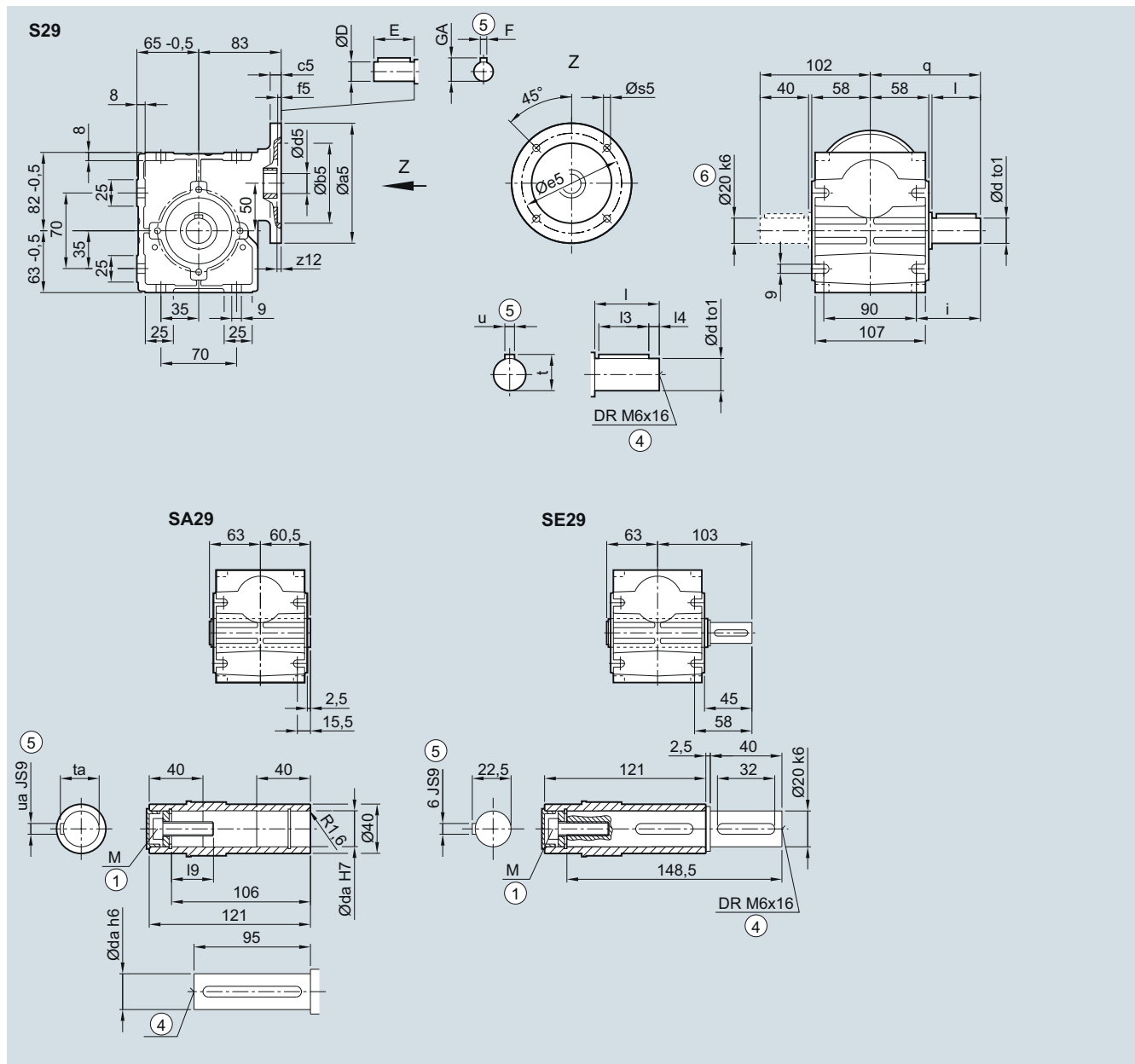

Solid shaft	d	to1	l	l3	l4	u	t	q	i	Hollow shaft	da	ua	ta	l9	M
	20	k6	40	32	4	6	22.5	102	57			20	6	22.8	23.4
25	k6	50	40	5	8	28.0	112	67		25	8	28.3	32.6	M10	
Adapter	a5	b5	c5	f5	e5	s5	z12	d5/D	E	F	GA				
63	90	60	8	3.0	75	5.8	6	11	23	4	12.5				
71	105	70	8	3.0	85	7.0	6	14	30	5	16.0				
80	120	80	8	3.5	100	7.0	6	19	40	6	21.5				

① ISO 4014

④ DIN 332

⑤ Feather key/keyway DIN 6885

⑥ Solid shaft with 2nd shaft extension only d20

S.F29 gearbox in a flange-mounted design

SF030, SAF030, SEF030

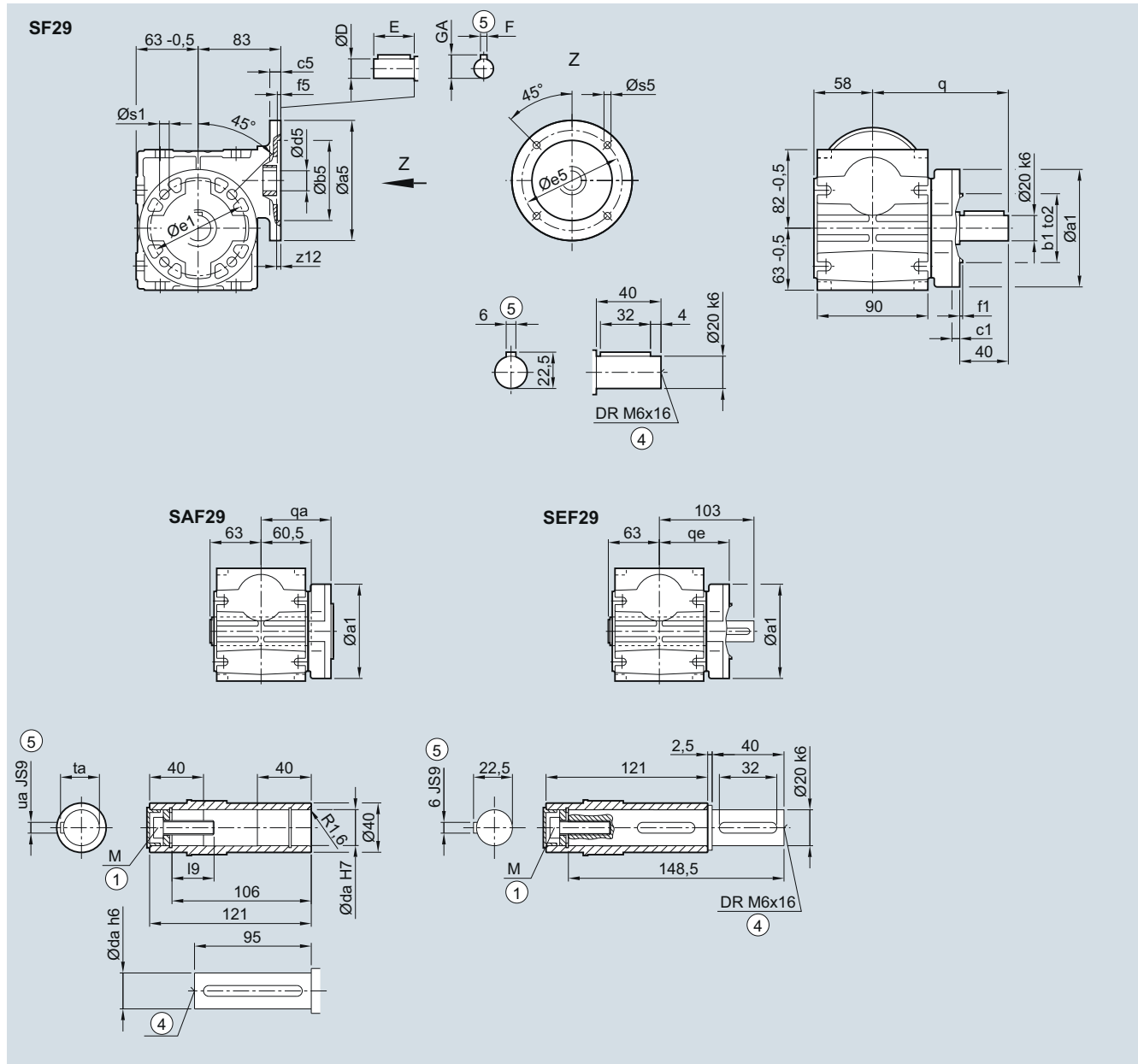

Hollow shaft	da	ua	ta	I9	M
	20	6	22.8	23.4	M6
	25	8	28.3	32.6	M10

Flange	a1	e1	b1	to2	c1	f1	s1	q	qa / qe
	120	100	80	j6	8	3.0	6.6	120	80
	160	130	110	j6	8	3.5	9.0	135	95

Adapter	a5	b5	c5	f5	e5	s5	z12	d5/D	E	F	GA
63	90	60	8	3	75	5.8	6	11	23	4	12.5
71	105	70	8	3	85	7.0	6	14	30	5	16.0
80	120	80	8	3.5	100	7.0	6	19	40	6	21.5

① ISO 4014

④ DIN 332

⑤ Feather key/keyway DIN 6885

SIMOGEAR Gearboxes

Worm gearbox with adapter K4

Dimensions

S.Z29 gearbox in a housing flange design

SZ030, SAZ030, SEZ030

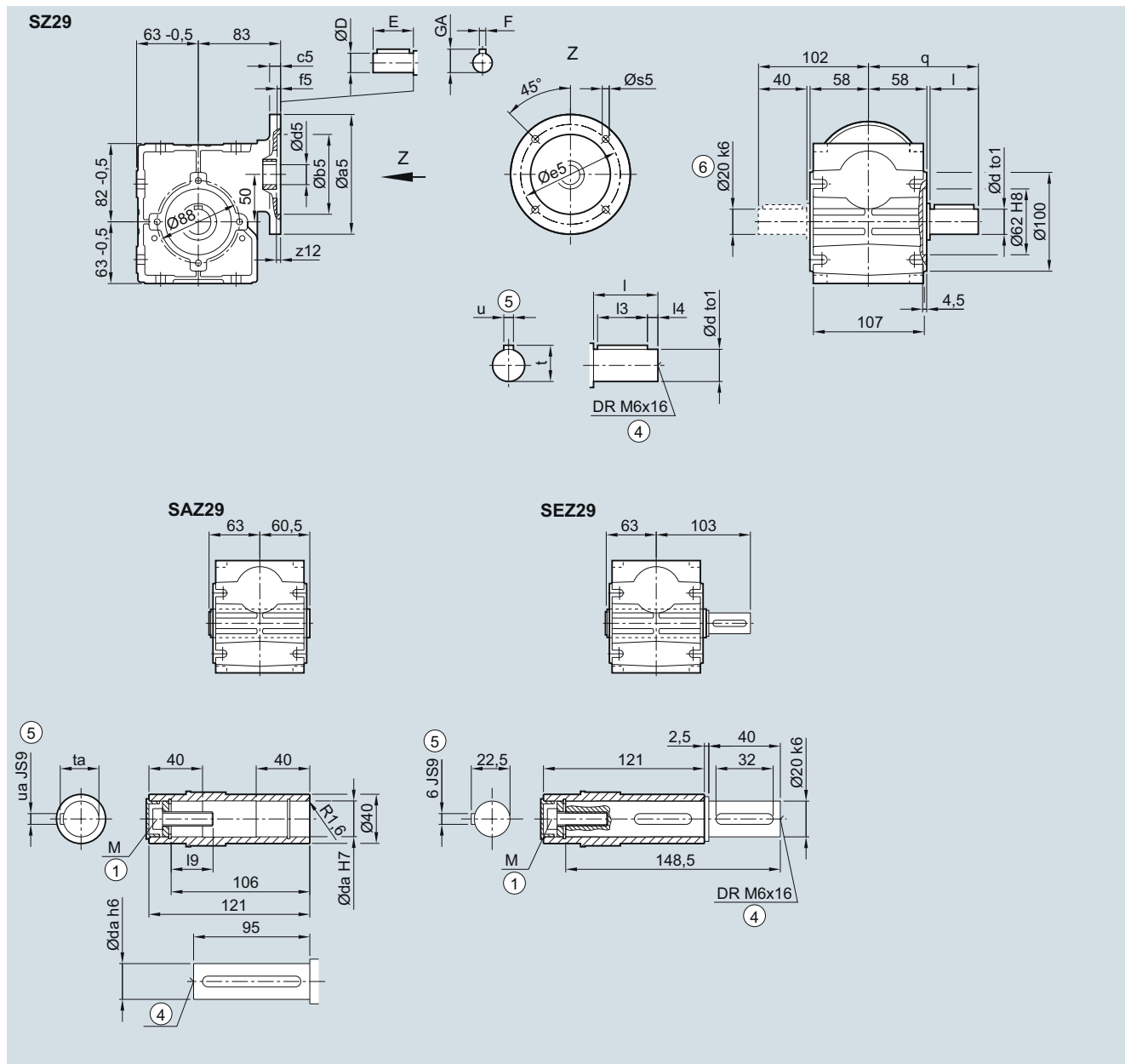

Solid shaft	d	to1	l	l3	l4	u	t	q	Hollow shaft				
	da	ua	ta	l9	M								
	20	k6	40	32	4	6	22.5	102	20	6	22.8	23.4	M6
	25	k6	50	40	5	8	28.0	112	25	8	28.3	32.6	M10

Adapter	a5	b5	c5	f5	e5	s5	z12	d5/D	E	F	GA
63	90	60	8	3	75	5.8	6	11	23	4	12.5
71	105	70	8	3	85	7.0	6	14	30	5	16.0
80	120	80	8	3.5	100	7.0	6	19	40	6	21.5

① ISO 4014

④ DIN 332

⑤ Feather key/keyway DIN 6885

⑥ Solid shaft with 2nd shaft extension only d20

SAD29 gearbox in a shaft-mounted design

SAD030

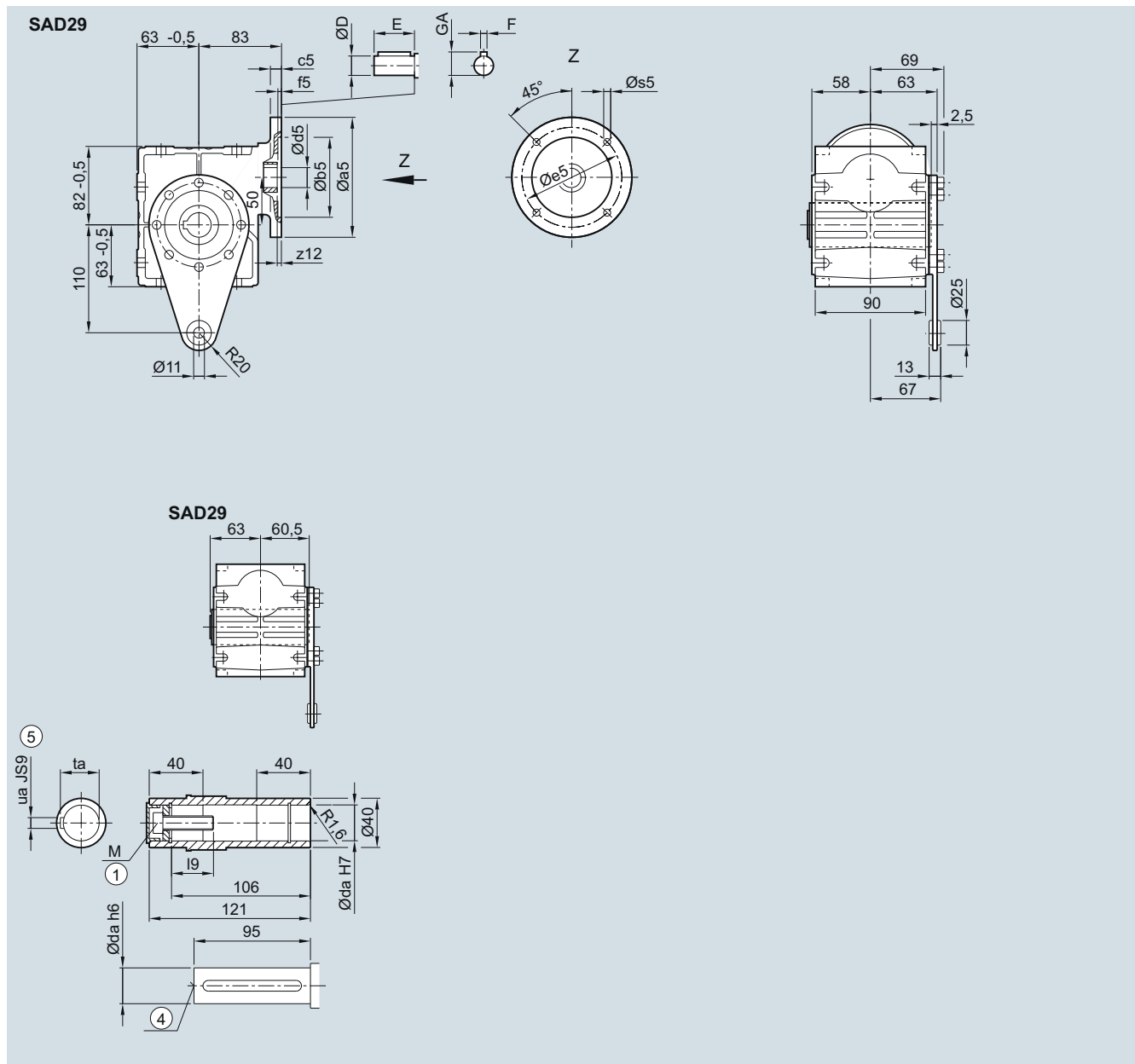

Hollow shaft	da	ua	ta	I9	M
	20	6	22.8	23.4	M6
	25	8	28.3	32.6	M10

Adapter	a5	b5	c5	f5	e5	s5	z12	d5/D	E	F	GA
63	90	60	8	3	75	5.8	6	11	23	4	12.5
71	105	70	8	3	85	7.0	6	14	30	5	16.0
80	120	80	8	3.5	100	7.0	6	19	40	6	21.5

① ISO 4014

④ DIN 332

⑤ Feather key/keyway DIN 6885

SIMOGEAR Gearboxes

Worm gearbox with adapter K4

Dimensions**Protection cover for hollow shaft**

SA, SAZ, SAF, SE, SEZ

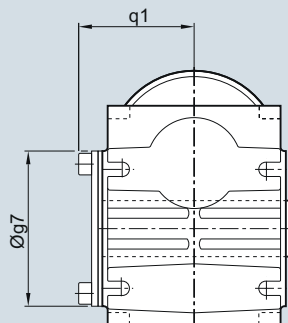

Gearbox type	S.09	S.19	S.29
Protection cover			
g7	72	82	100
q1	51	59.5	70

Adapters

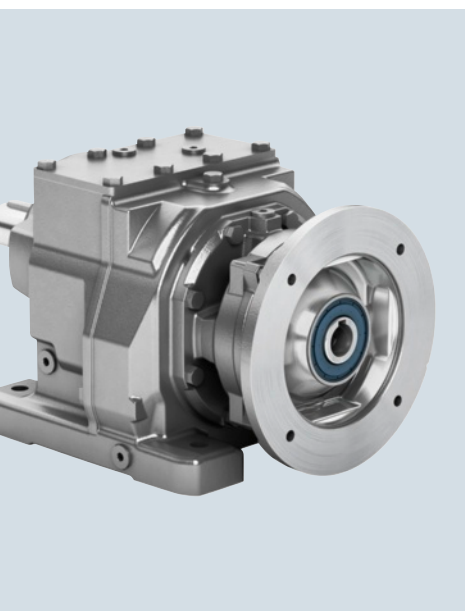

8/2

Orientation

8/2

Overview

8/2

Adapters for mounting an IEC motor

8/3

Adapters for mounting a servo motor

8/3

Adapters for mounting a NEMA motor

8/4

General technical specifications

8/4

Adapters for mounting an IEC motor

8/4

Adapters for mounting a servo motor

8/5

Adapters for mounting a NEMA motor

SIMOGEAR Gearboxes

Adapters

Orientation

Overview

For most applications, it is best to mount the motor so that it is integrated on the gearbox. This provides an optimum solution in terms of a short overall length and the least weight.

Please refer to our catalog [MD 50.1](#) for SIMOGEAR geared motors with integrated motor mounting.

The SIMOGEAR gearboxes with adapter make it possible to attach standard motors for special applications, e.g. which require motor versions that are not available as integrated motors.

Adapters for mounting an IEC motor

The adapters for mounting IEC motors are designed for IEC B5 flanges and make it easy to attach standard IEC motors.

We advise you to check the geometric dimensions of the motor flange.

Article No. at 12th position

Short adapter K4

4

Short adapter K2

2

Available adapter sizes for IEC motors

Adapter type and size		IEC motor	Diameter	Motor shaft
K4	K2	Shaft height	B5 flange	
			mm	mm
63	-	63	140	11
71	-	71	160	14
80	80	80	200	19
90	90	90	200	24
100	100	100	250	28
112	112	112	250	28
132	132	132	300	38
160	160	160	350	42
180	180	180	350	48
200	200	200	400	55
225	225	225	450	60
250	250	250	550	65
-	280	280	550	75
-	315	315	660	80

Short adapter K4

This adapter is suitable for attaching standard IEC motors for which a very short overall length is required in order to mount the motor.

The adapter is designed to allow the correction of axial alignment errors. The location bearing of the attached motor can be at the D or the ND end.

Note

For applications with high switching frequency and load classification III, we recommend the use of coupling adapter K2.

Coupling adapter K2

The adapter K2 for motors in IEC sizes is suitable for general applications with all load types.

The adapter is designed with a torsionally flexible cam coupling and transmits power in such a way as to damp torsional vibrations.

Adapters for mounting a servo motor

The adapters for mounting servo motors are designed for use with SIMOTICS S-1FK7/-1FT7 and SIMOTICS M-1PH8 servo motors.
We advise you to check the geometric dimensions of the motor flange.

Article No. at 12th position

Short adapter KQ

7

Short adapter K8

8

Available adapter sizes for servo motors

Adapter type and size		Flange dimensions				Motor shaft	Supported motors	
KQ	K8	a1	a5	b5	e5			
		mm	mm	mm	mm	mm		
703		□90	72x72	60	75	14x30	1FK703...	1FT703...
704		□120	96x96	80	100	19x40	1FK704...	1FT704...
706		□155	126x126	110	130	24x50	1FK706...	1FT706...
708		□195	155x155	130	165	32x58	1FK708...	1FT708...
710		□245	192.5x192.5	180	215	38x80	1FK710...	1FT710...
	808	□195	155x155	130	165	32x80	1PH808...	
	810	□245	192.5x192.5	180	215	38x80	1PH810...	
	813	□340	260x260	250	300	48x110	1PH813...	
	816	□392	314x314	300	350	55x110	1PH816...	
	818	Ø550	550	450	465	65x140	1PH818...	
	822	Ø660	660	550	465	75x140	1PH822...	

Coupling adapter KQ for mounting servo motors from the SIMOTICS S-1FK7/-1FT7 ranges

This adapter can be used to attach servo motors from the SIMOTICS S-1FK7/-1FT7 ranges with square flanges to the gearbox. This provides the geared motor with a solid and attractive design.

The adapter is designed with a zero-backlash, torsionally flexible cam coupling and transmits power in such a way as to damp torsional vibrations.

The adapter KQ is designed for motor shafts with feather key. The adapter KQS is available as an alternative for motor shafts without feather key, see [chapter "Adapter options"](#).

Coupling adapter K8 for mounting a motor from the SIMOTICS M-1PH8 range

The adapter K8 can be used to attach motors with feather key from the SIMOTICS M-1PH8 range.

The adapter is designed with a torsionally flexible cam coupling and transmits power in such a way as to damp torsional vibrations.

Adapters for mounting a NEMA motor

The adapters for mounting NEMA motors are designed for NEMA TC flanges and make it easy to attach standard NEMA motors.

We advise you to check the geometric dimensions of the motor flange.

Article No. at 12th position

Short adapter K5

5

Short adapter K3

3

Available adapter sizes for NEMA motors

Adapter type and size		NEMA	Flange dimension	Motor shaft
K5	K3		Inch	Inch
56	56	56C	6.61"	0.625"
140	140	140TC (143TC, 145TC)	6.61"	0.875"
180	180	180TC (182TC, 184TC)	8.9"	1.125"
210	210	210TC (213TC, 215TC)	8.9"	1.375"
250	250	250TC (254TC, 256TC)	8.9"	1.625"
280	280	280TC (284TC, 286TC)	11.22"	1.875"
320	320	320TC (324TC, 326TC)	13.386"	2.125"
360	360	360TC (364TC, 365TC)	13.386"	2.375"

Short adapter K5

This adapter is suitable for attaching motors in NEMA sizes for which a very short overall length is required in order to mount the motor.

The adapter is designed to allow the correction of axial alignment errors. The location bearing of the attached motor can be at the D or the ND end.

Note

For applications with high switching frequency and load classification III, we recommend the use of coupling adapter K3.

Coupling adapter K3

The adapter K3 for motors in NEMA sizes is suitable for general applications with all load types.

The adapter is designed with a torsionally flexible cam coupling and transmits power in such a way as to damp torsional vibrations.

SIMOGEAR Gearboxes

Adapters

General technical specifications

Adapters for mounting an IEC motor

The input torques T_{1perm} listed in the table must not be exceeded in continuous operation.

It is permissible for the input torque to increase to 2.5 times the value of T_{1perm} for brief periods.

Adapter size	Permissible input torque for continuous operation T_{1perm} Nm	Mass inertia of the adapter J 10^{-4} kgm ²
Adapter K4		
63	3.2	0.33
71	3.2	0.32
80	10	2.49
90	13	2.36
100	33	6.36
112	33	6.36
132	95	33.2
160	121	38.0
180	160	35.7
200	215	93.1
225	325	95.4
250	400	137.0
Adapter K2		
80	10	3.00
90	13	2.98
100	33	8.99
112	33	8.99
132	95	36.4
160	121	42.8
180	160	74.7
200	215	124
225	325	179
250	400	293
280	650	703
315	1 450	2 267

Adapters for mounting a servo motor

The input torques T_{1perm} listed in the table must not be exceeded in continuous operation.

It is permissible for the input torque to increase to 2.5 times the value of T_{1perm} for brief periods.

Adapter size	Permissible input torque for continuous operation T_{1perm} Nm	Mass inertia of the adapter J 10^{-4} kgm ²	Maximum permissible speed n_{max} rpm
Adapter KQ			
703	3.2	0.26	4 500
704	13	1.72	4 500
706	13	3.35	4 500
708	33	9.16	4 500
710	121	34.2	4 500
Adapter K8			
808	33	9.16	4 500
810	121	34.2	4 500
813	160	72.6	4 500
816	265	134	4 500
818	650	703	4 500
822	1 450	2 267	4 500

Adapters for mounting a NEMA motor

The input torques T_{1perm} listed in the table must not be exceeded in continuous operation.

It is permissible for the input torque to increase to 2.5 times the value of T_{1perm} for brief periods.

Adapter size	Permissible input torque for continuous operation T_{1perm} Nm	Mass inertia of the adapter J 10^{-4} kgm^2
Adapter K5		
56	3.2	0.33
140	13	2.36
180	33	6.36
210	95	33.2
250	121	38.0
280	160	35.7
320	215	93.1
360	400	137
Adapter K3		
56	3.2	2.94
140	13	2.98
180	33	8.99
210	95	36.4
250	121	42.8
280	160	74.7
320	215	124
360	400	293

SIMOGEAR Gearboxes

Notes

Gearbox options

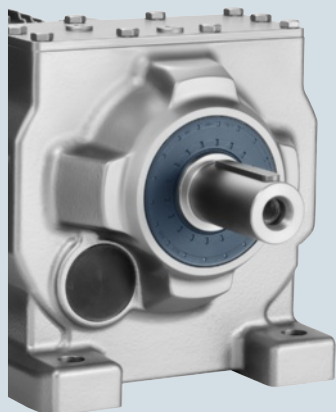
**9/2 Mounting position**

- 9/2 Overview
- 9/4 Helical gearbox
- 9/4 Foot-mounted design
- 9/6 Foot/flange-mounted design
- 9/8 Flange-mounted design or with housing flange
- 9/11 Parallel shaft gearbox
- 9/11 Shaft-mounted design
- 9/13 Flange-mounted design or with housing flange
- 9/15 Foot-mounted design
- 9/17 Bevel gearbox B
- 9/17 Foot-mounted design
- 9/19 Housing flange design and flange-mounted design
- 9/21 Shaft-mounted design
- 9/23 Bevel gearbox K
- 9/23 Foot-mounted design
- 9/24 Housing flange design and flange-mounted design
- 9/25 Shaft-mounted design
- 9/26 Helical worm gearbox C
- 9/26 Shaft-mounted design
- 9/28 Housing flange design and flange-mounted design
- 9/30 Foot-mounted design
- 9/32 Worm gearbox S
- 9/32 Foot-mounted, flange-mounted, shaft-mounted and housing flange designs
- 9/33 Special mounting positions

9/34 Mounting

- Mounting types
- 9/34 Overview
- 9/35 Flange-mounted designs
- 9/36 • Water drain holes at the output flange
- 9/37 Parallel shaft gearboxes F.AD in a shaft-mounted design
- 9/37 Bevel gearboxes KAD in a shaft-mounted design
- 9/37 Bevel gearboxes BAD in a shaft-mounted design
- 9/38 Helical worm gearboxes CAD in shaft-mounted design
- 9/38 Worm gearboxes SAD in shaft-mounted design
- 9/39 Shaft designs
- 9/39 Selection and ordering data
- 9/41 Hollow shaft with SIMOLOC assembly system
- 9/42 Hollow shaft cover

9/42 Output shaft bearings

- 9/42 Radially reinforced output shaft bearings

9/43 Lubrication and sealing

- Lubrication
- 9/43 Overview
- 9/43 Oil quantities
- 9/43 Sealing system
- 9/43 Roller bearing greases for gearboxes and motors
- Sealing
- 9/43 Overview
- 9/44 Selection

9/45 Venting and oil level control

- Venting
- 9/45 Overview
- 9/46 Pressure breather valve
- 9/47 Oil expansion unit
- 9/49 Oil level control
- 9/49 Oil sight glass
- 9/49 Oil drain

9/50 Reduced-backlash version

- 9/50 Overview

Gearbox options

Mounting position

Overview

The mounting position must be specified when you place your order to ensure that the gearbox is supplied with the correct quantity of oil.

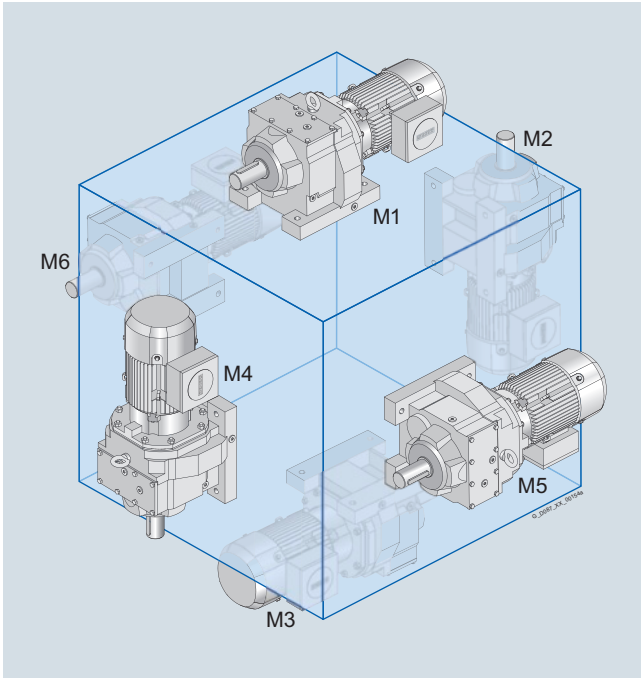

Fig. 9/1 Helical geared motors

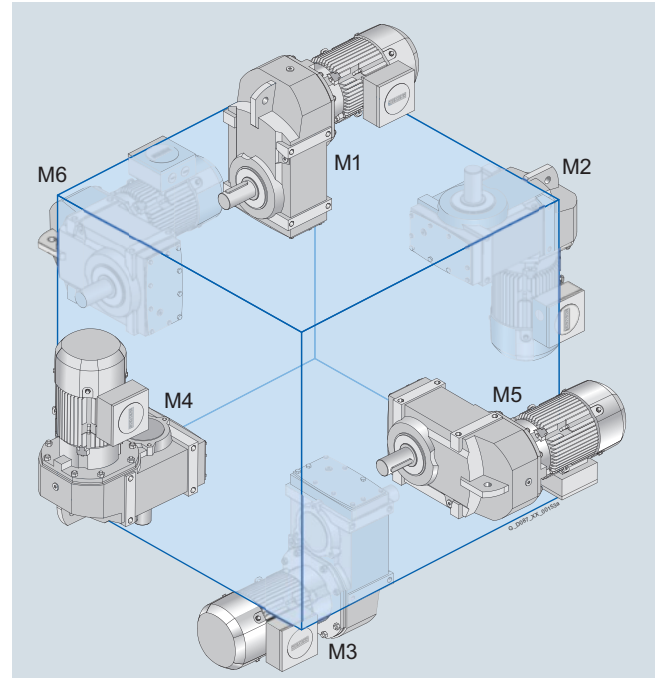

Fig. 9/2 Parallel shaft geared motors

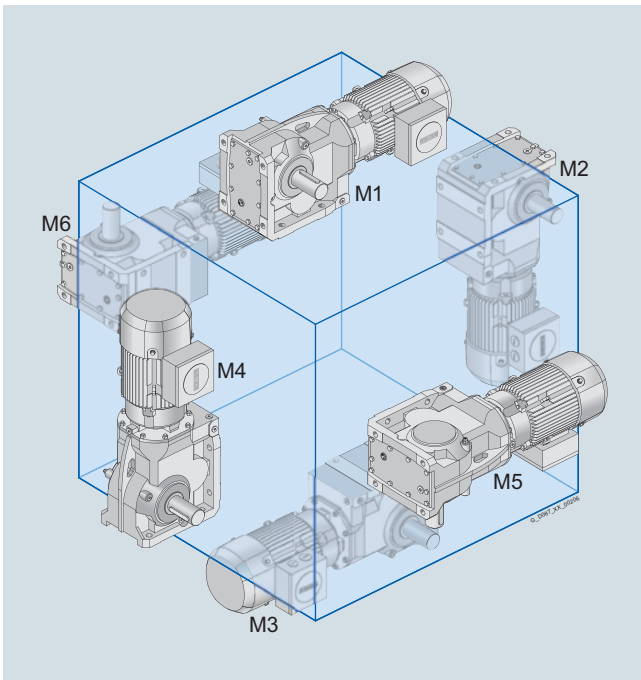

Fig. 9/3 Bevel geared motors

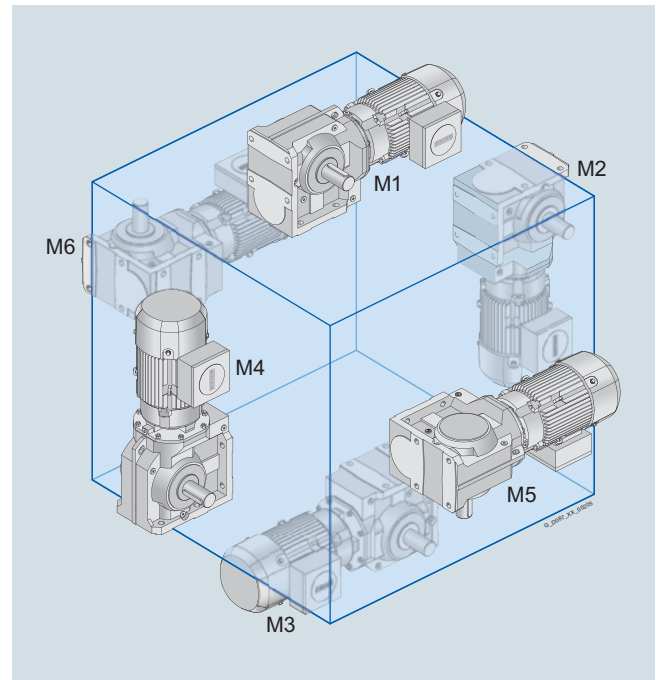

Fig. 9/4 Helical worm geared motors

Overview (continued)

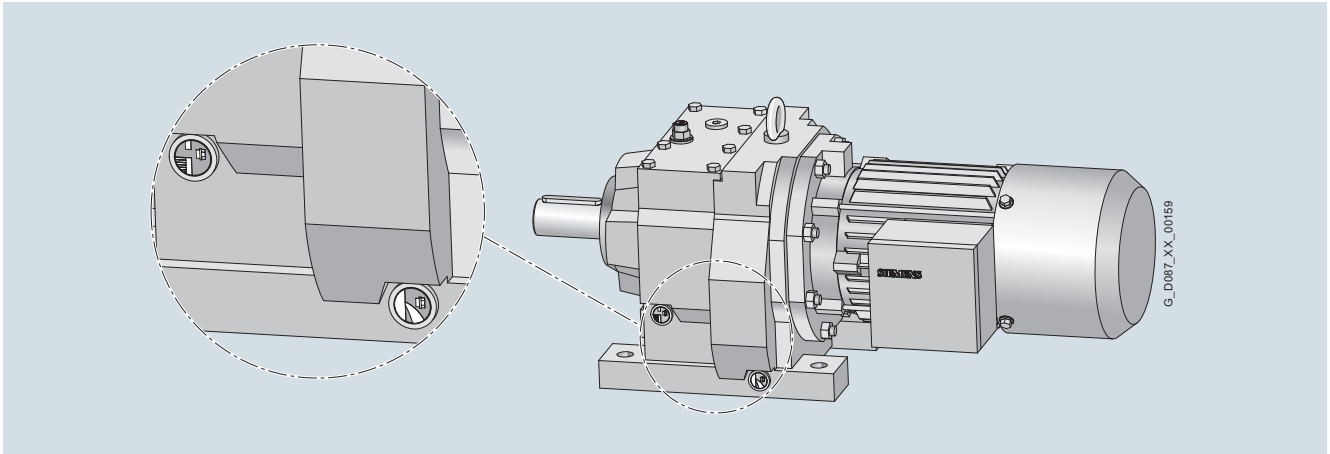

Fig. 9/5 Dimensional drawing from EKat with details

Note:

Utilize the new function of our [SIMOGEAR Configurator](#) electronic catalog.

For the selected mounting position, the 3D dimensional drawings show the exact position of the oil valves.

Explanation of symbols

Symbol

Oil valves



Venting



Oil drain



Oil level checking screw

Supplements

*	On opposite side
A, B	Output side A, output side B
②	2-stage gearbox
③	3-stage gearbox
① ... ④	Terminal box position
A ... D	Position of the cable entry

Gearbox options

Mounting position

Helical gearboxes

Foot-mounted design

Helical gearboxes Z and D, size 29

Oil valves

Sizes 19 and 29 are lubricated for life.

M1

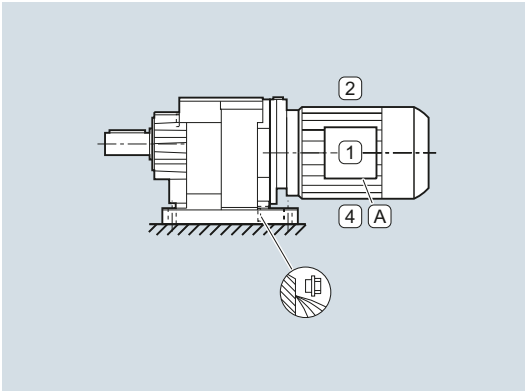

Order code:

M1

D01

M2

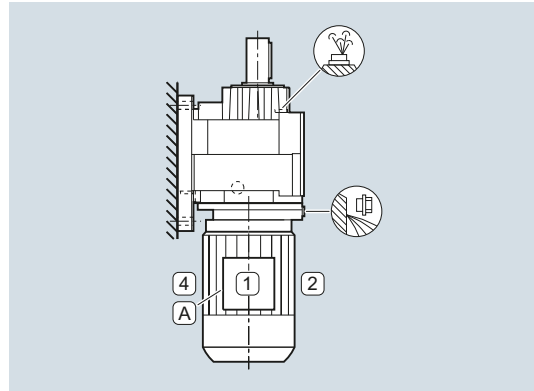

Order code:

M2

D02

M3

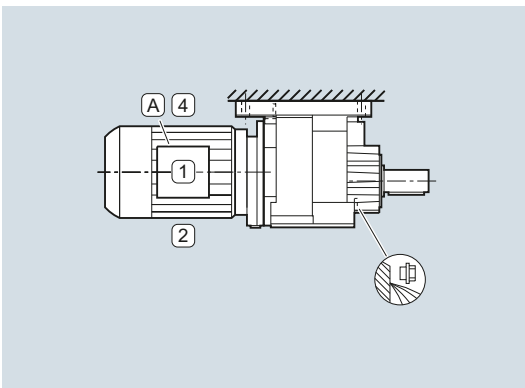

Order code:

M3

D03

M4

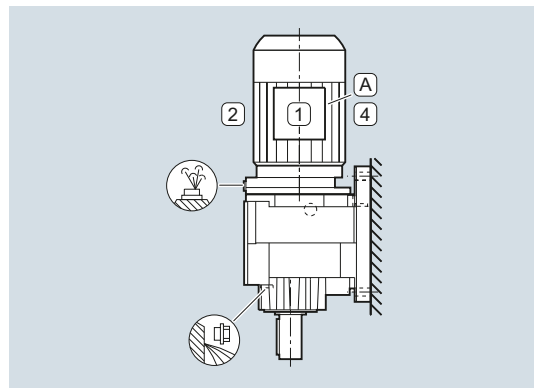

Order code:

M4

D04

M5

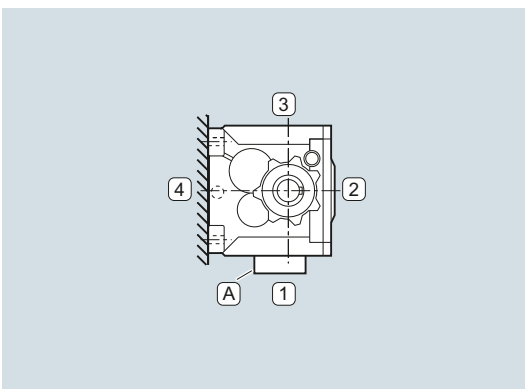

Order code:

M5

D05

M6

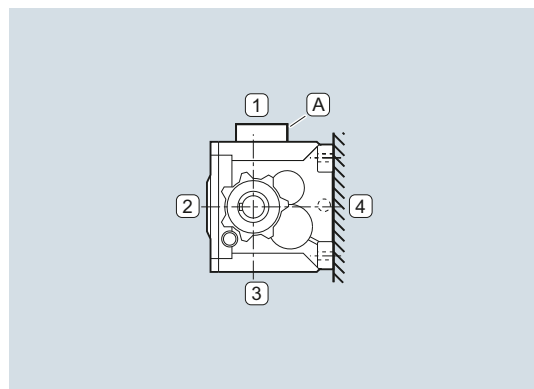

Order code:

M6

D06

Foot-mounted design (continued)

Helical gearboxes Z and D, sizes 39 to 189

Oil valves

M1

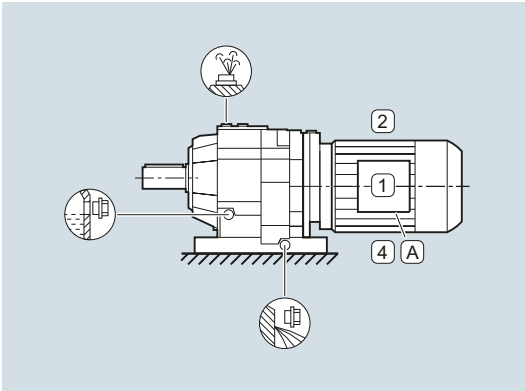

Order code:

M1

D01

M2

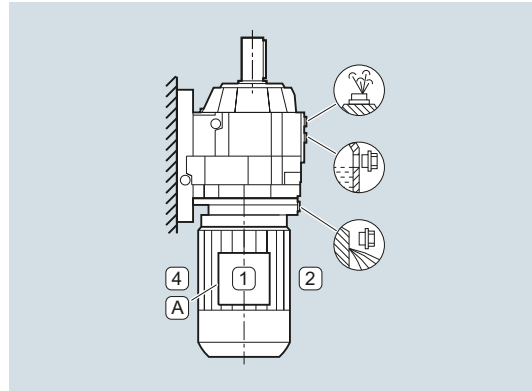

Order code:

M2

D02

M3

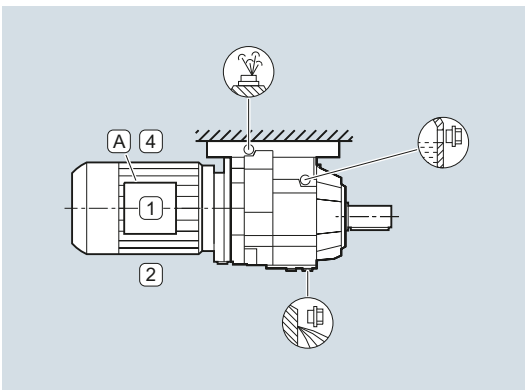

Order code:

M3

D03

M4

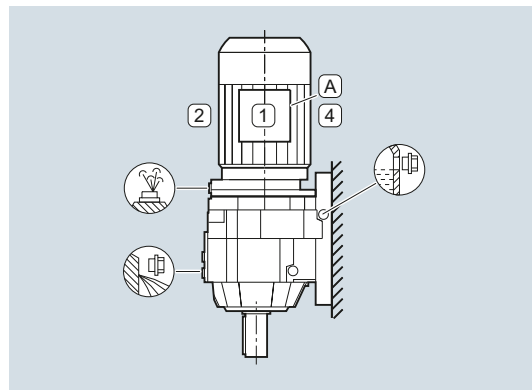

Order code:

M4

D04

M5

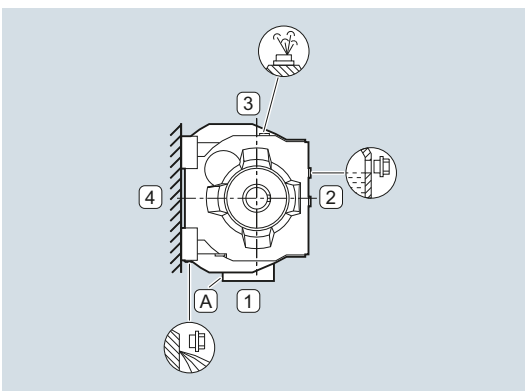

Order code:

M5

D05

M6

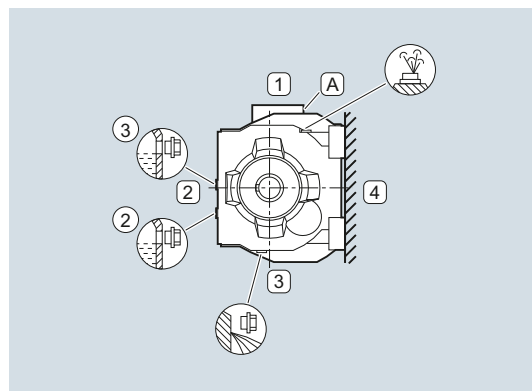

Order code:

M6

D06

Gearbox options

Mounting position

Helical gearboxes

Foot/flange-mounted design

Helical gearboxes ZB and DB, size 29

Oil valves

Size 29 is lubricated for life.

M1

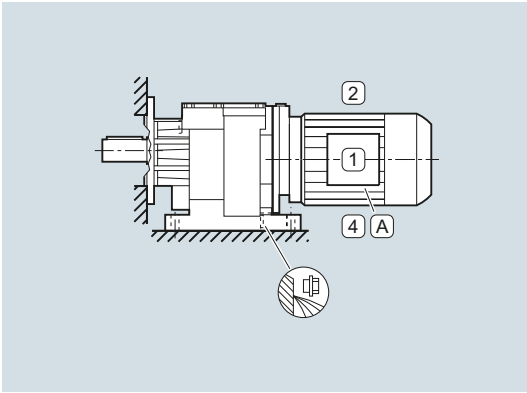

Order code:

M1

D01

M2

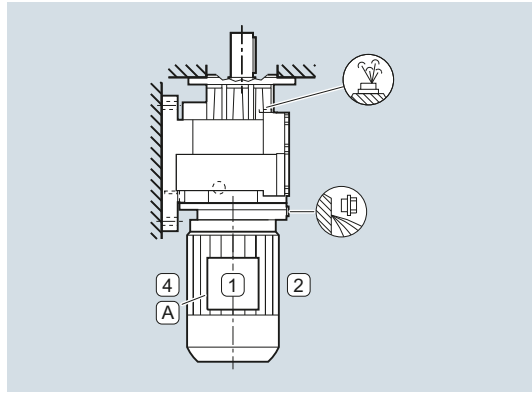

Order code:

M2

D02

M3

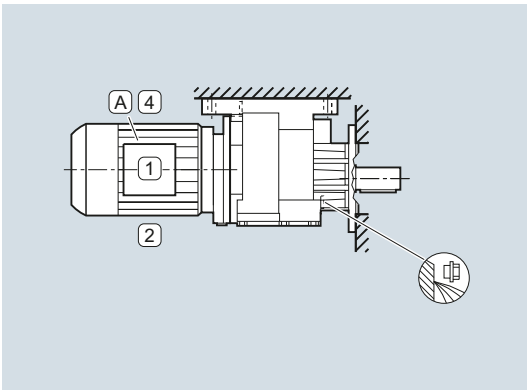

Order code:

M3

D03

M4

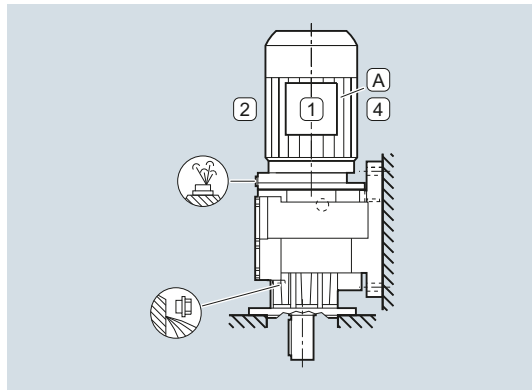

Order code:

M4

D04

M5

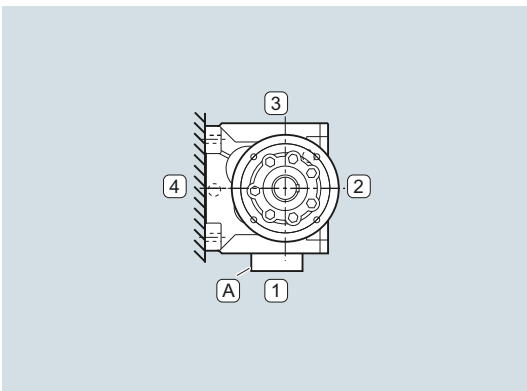

Order code:

M5

D05

M6

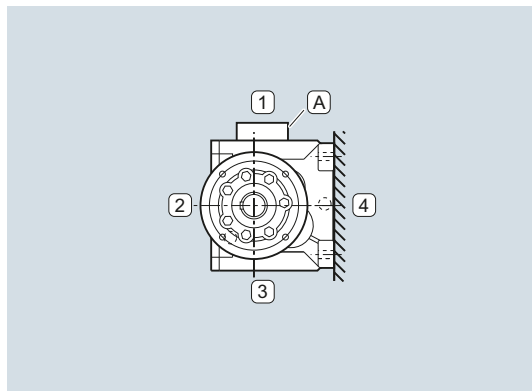

Order code:

M6

D06

Foot/flange-mounted designs (continued)

Helical gearboxes ZB and DB, sizes 39 to 89

Oil valves

M1

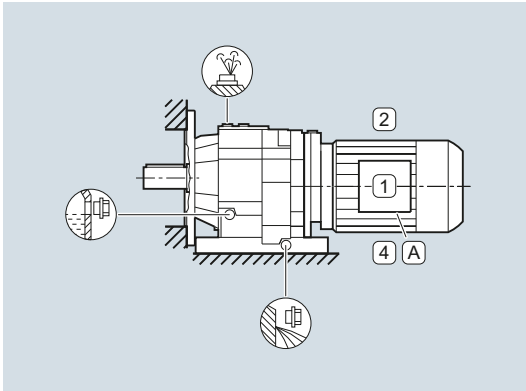

Order code:

M1

D01

M2

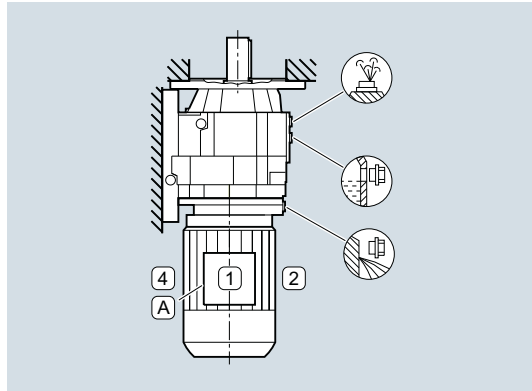

Order code:

M2

D02

M3

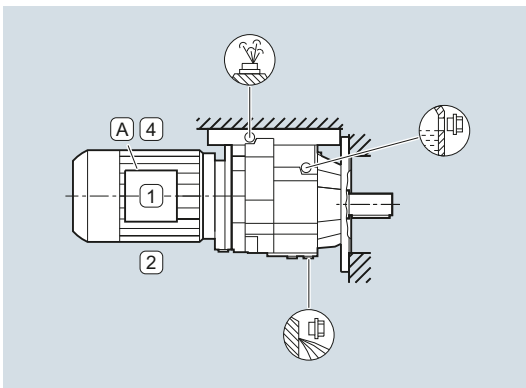

Order code:

M3

D03

M4

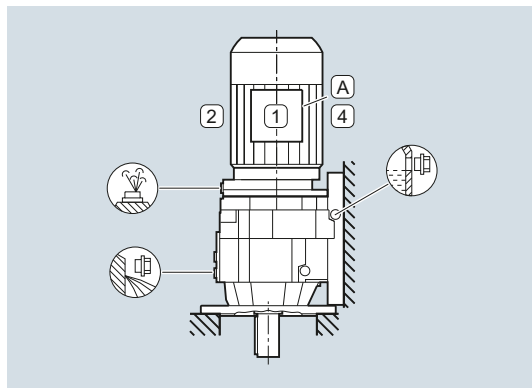

Order code:

M4

D04

M5

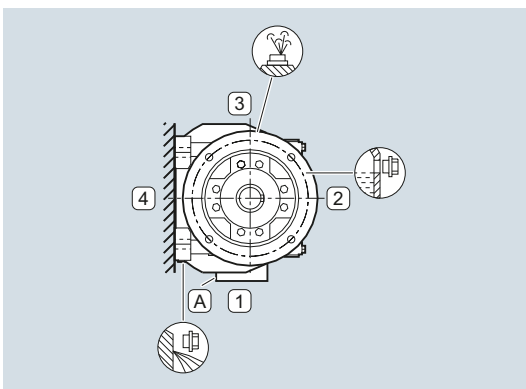

Order code:

M5

D05

M6

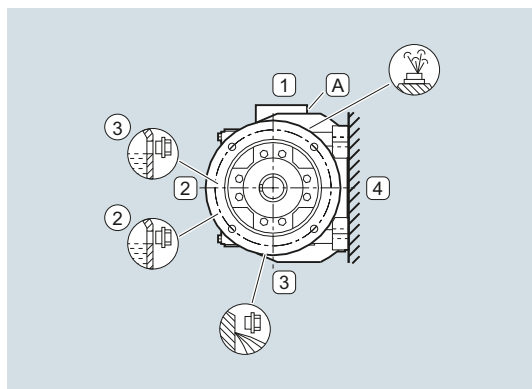

Order code:

M6

D06

Gearbox options

Mounting position

Helical gearboxes

Flange-mounted design or with housing flange

Helical gearboxes ZF and DF or ZZ and DZ, size 29

Oil valves

Sizes 19 and 29 are lubricated for life.

M1

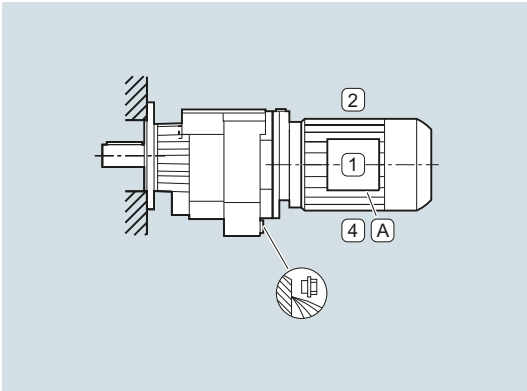

Order code:

M1

D01

M2

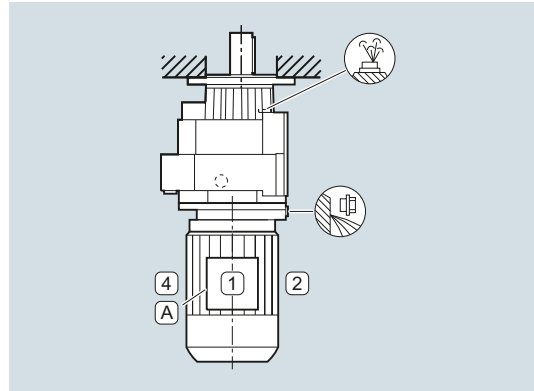

Order code:

M2

D02

M3

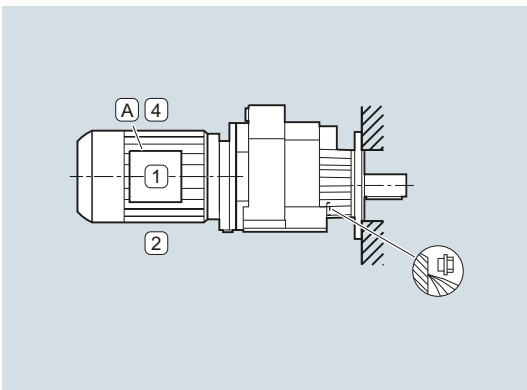

Order code:

M3

D03

M4

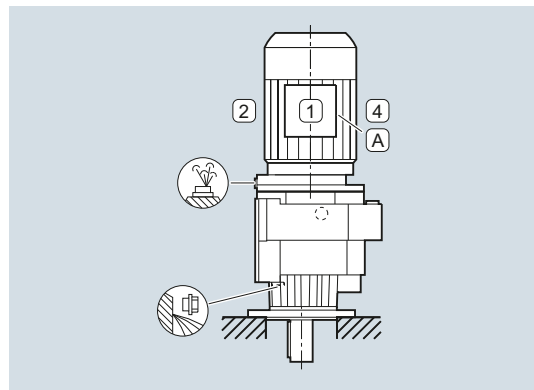

Order code:

M4

D04

M5

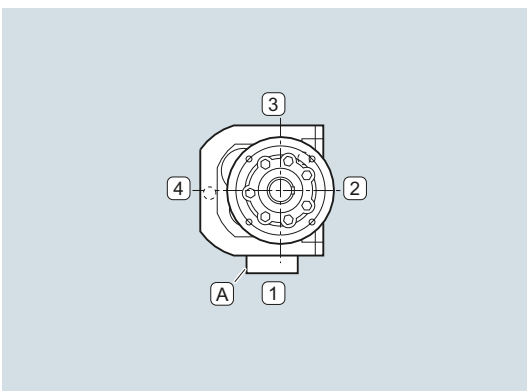

Order code:

M5

D05

M6

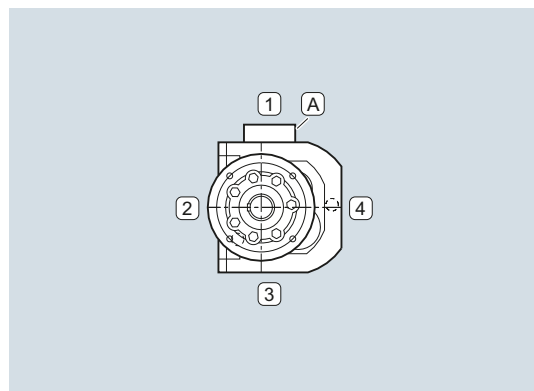

Order code:

M6

D06

Flange-mounted design or with housing flange (continued)

Helical gearboxes ZF and DF or ZZ and DZ, size 39

Oil valves

M1

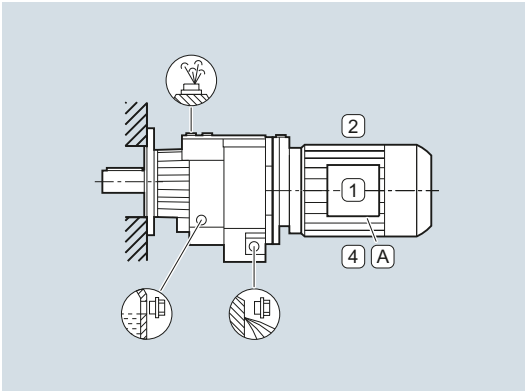

Order code:

M1

D01

M2

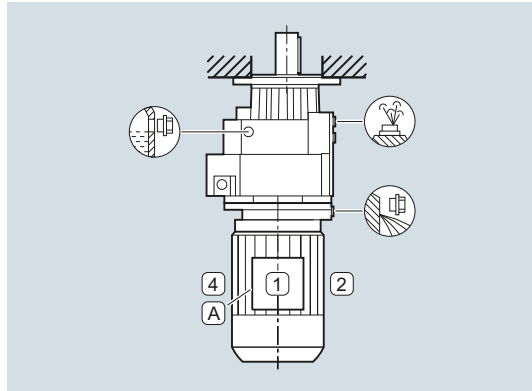

Order code:

M2

D02

M3

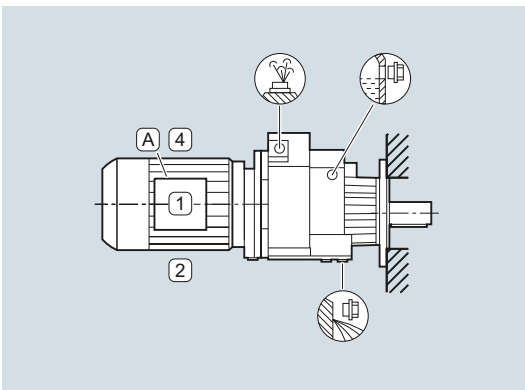

Order code:

M3

D03

M4

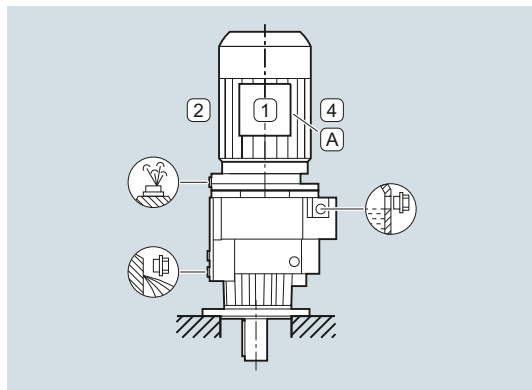

Order code:

M4

D04

M5

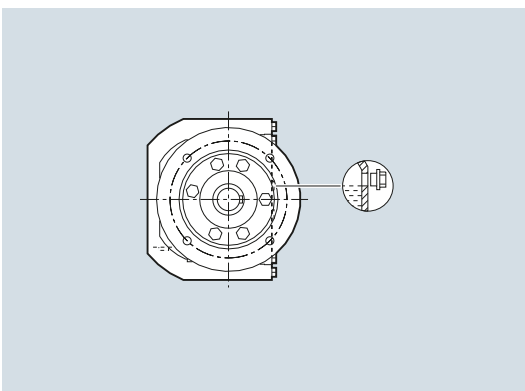

Order code:

M5

D05

M6

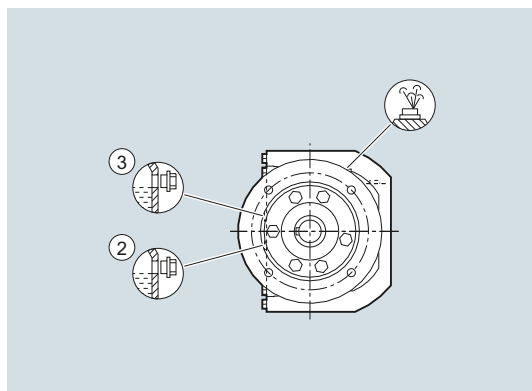

Order code:

M6

D06

Gearbox options

Mounting position

Helical gearboxes

Flange-mounted design or with housing flange (continued)

Helical gearboxes ZF and DF, sizes 49 to 189, or ZZ and DZ, sizes 49 to 129

Oil valves

M1

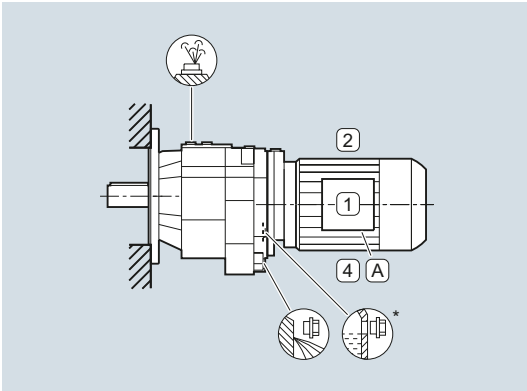

Order code:

M1

D01

M2

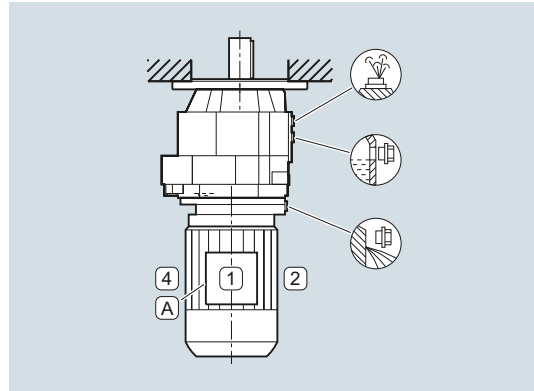

Order code:

M2

D02

M3

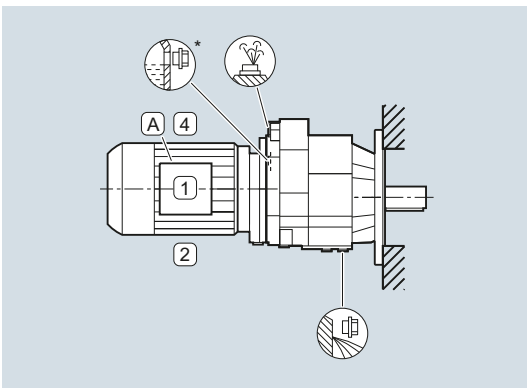

Order code:

M3

D03

M4

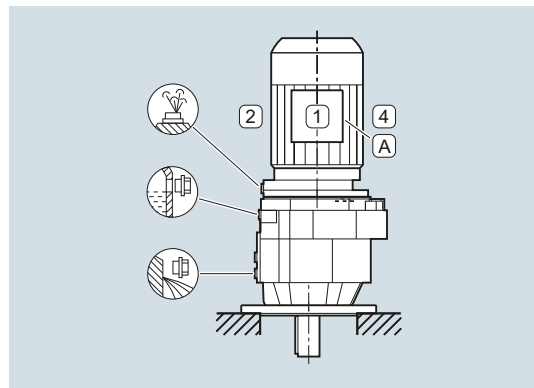

Order code:

M4

D04

M5

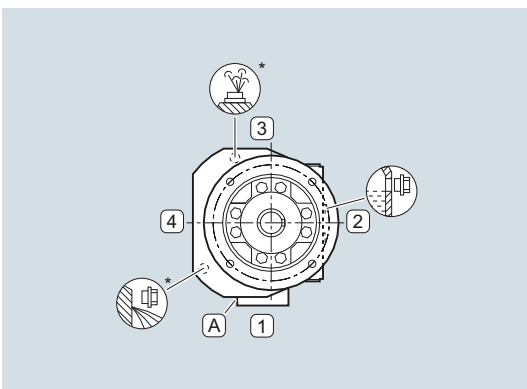

Order code:

M5

D05

M6

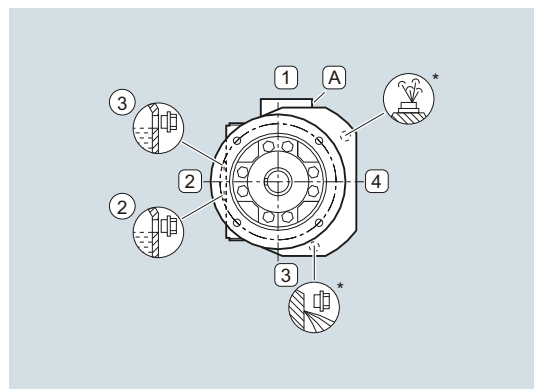

Order code:

M6

D06

Shaft-mounted design

Parallel shaft gearboxes F.AD, size 29

Oil valves

Size 29 is lubricated for life.

M1

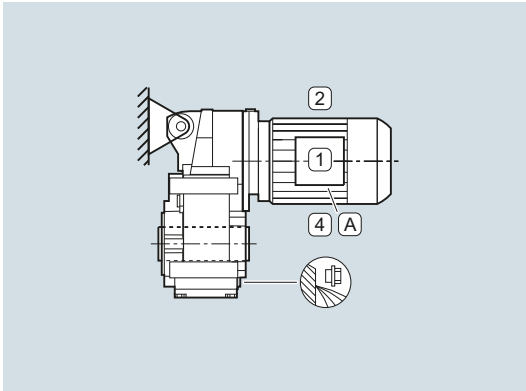

Order code:

M1

D01

M2

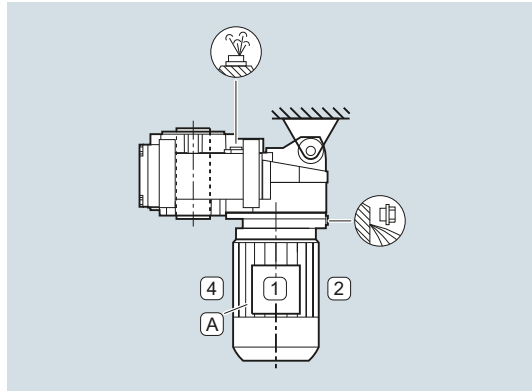

Order code:

M2

D02

M3

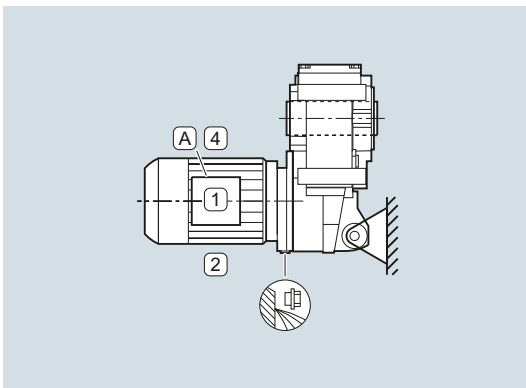

Order code:

M3

D03

M4

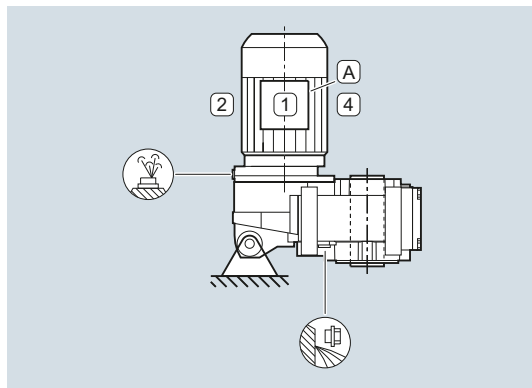

Order code:

M4

D04

M5

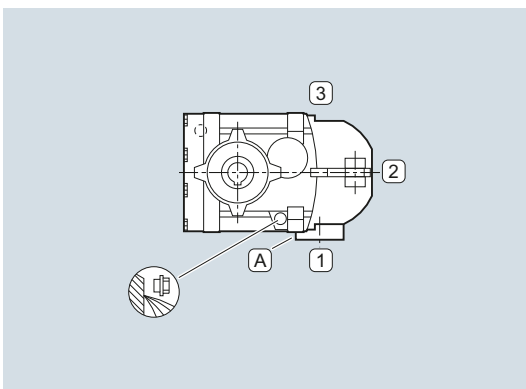

Order code:

M5

D05

M6

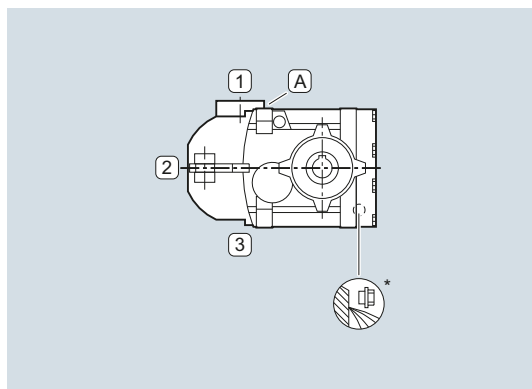

Order code:

M6

D06

Gearbox options

Mounting position

Parallel shaft gearboxes

Shaft-mounted design (continued)

Parallel shaft gearboxes F.AD, sizes 39 to 189

Oil valves

M1

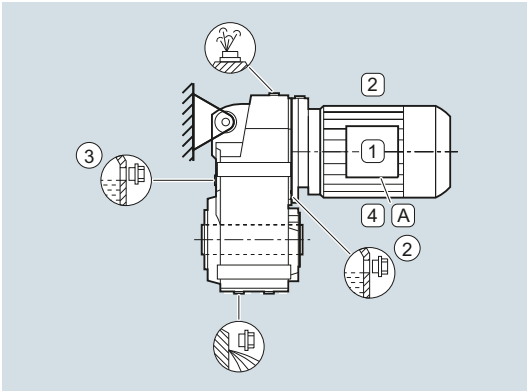

Order code:

M1

D01

M2

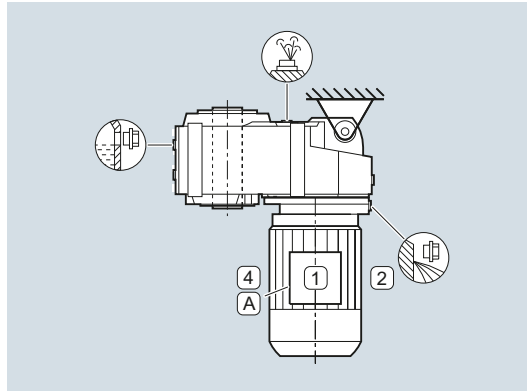

Order code:

M2

D02

M3

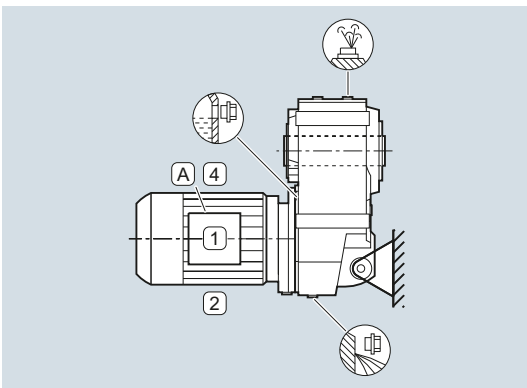

Order code:

M3

D03

M4

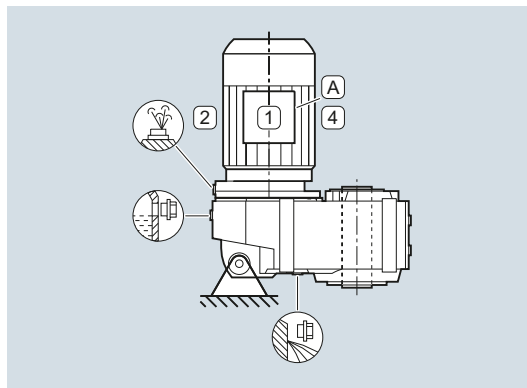

Order code:

M4

D04

M5

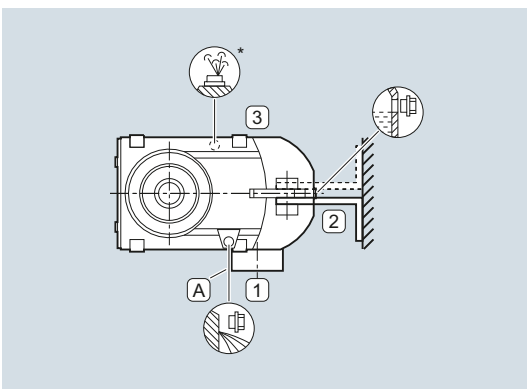

Order code:

M5

D05

M6

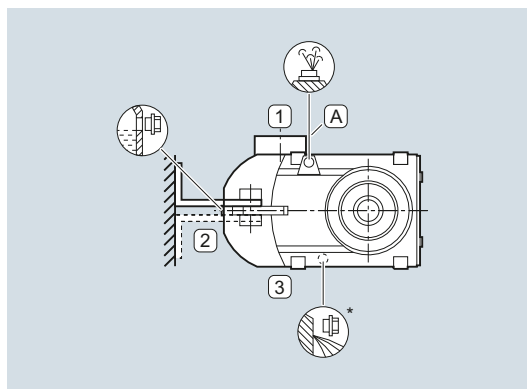

Order code:

M6

D06

Flange-mounted design or with housing flange

Parallel shaft gearboxes F..F or F..Z, size 29

Oil valves

Size 29 is lubricated for life.

M1

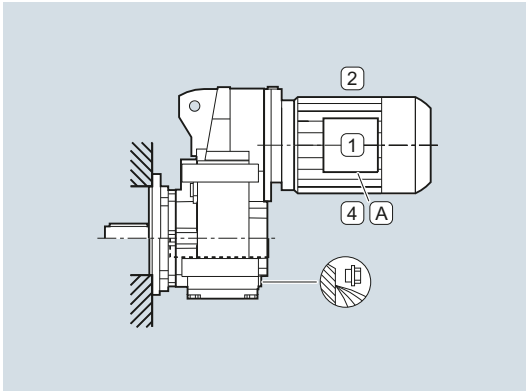

Order code:

M1

D01

M2

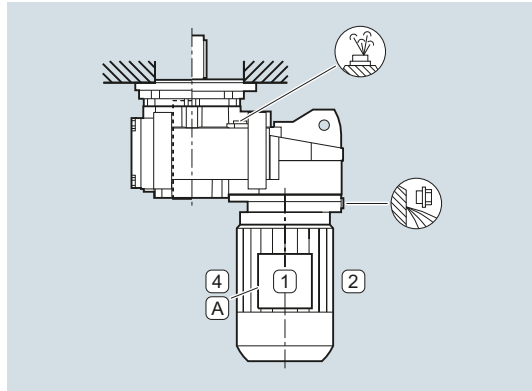

Order code:

M2

D02

M3

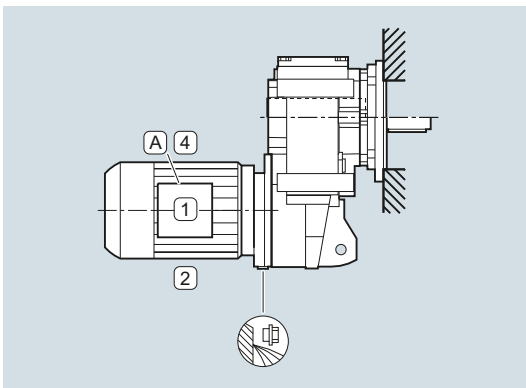

Order code:

M3

D03

M4

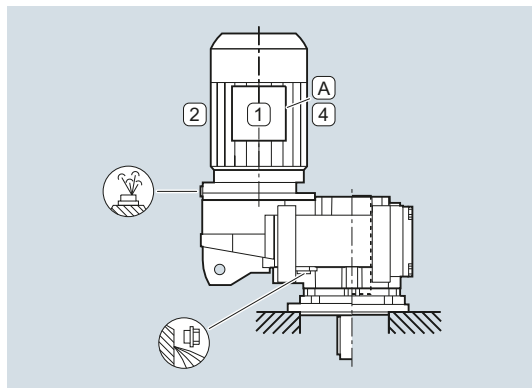

Order code:

M4

D04

M5

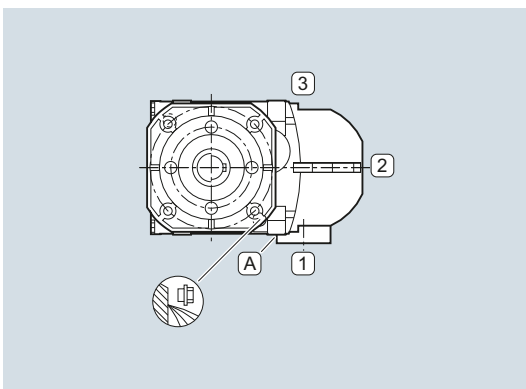

Order code:

M5

D05

M6

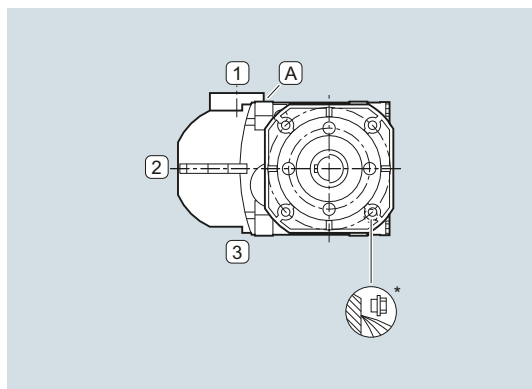

Order code:

M6

D06

Gearbox options

Mounting position

Parallel shaft gearboxes

Flange-mounted design or with housing flange (continued)

Parallel shaft gearboxes F..F or F..Z, sizes 39 to 189

Oil valves

M1

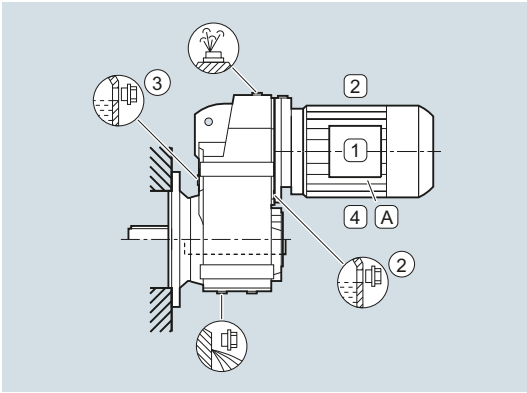

Order code:

M1

D01

M2

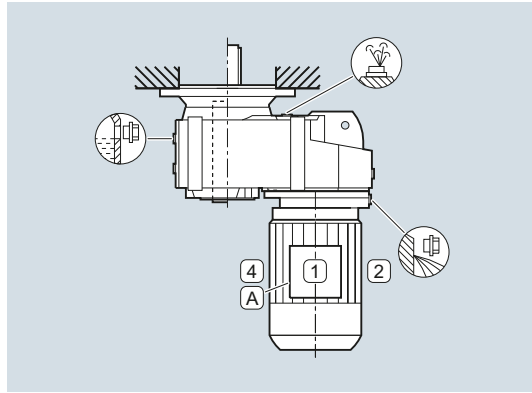

Order code:

M2

D02

M3

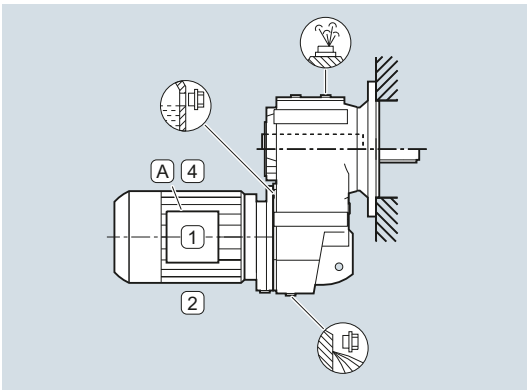

Order code:

M3

D03

M4

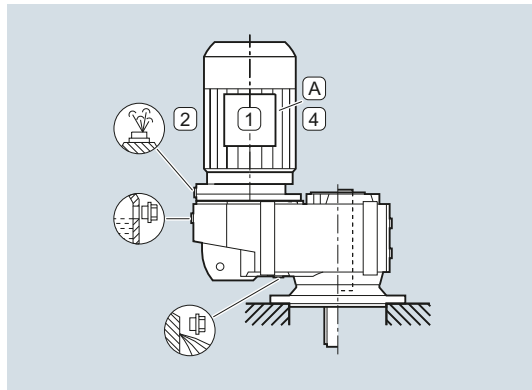

Order code:

M4

D04

M5

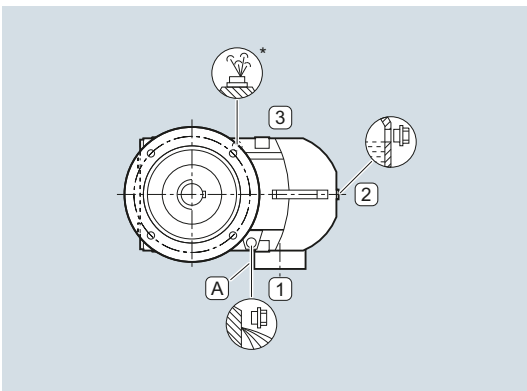

Order code:

M5

D05

M6

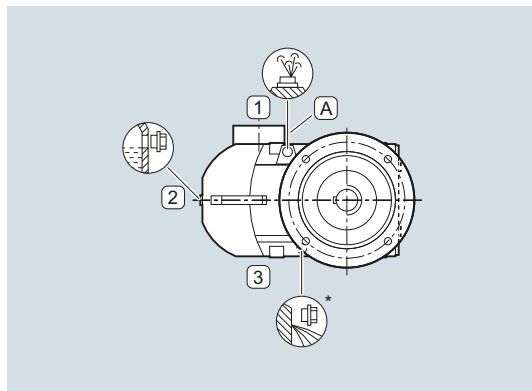

Order code:

M6

D06

Foot-mounted design

Parallel shaft gearboxes F, size 29

Oil valves

M1

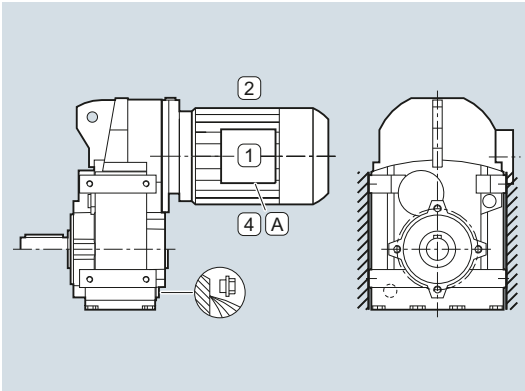

Order code:

M1

D01

M2

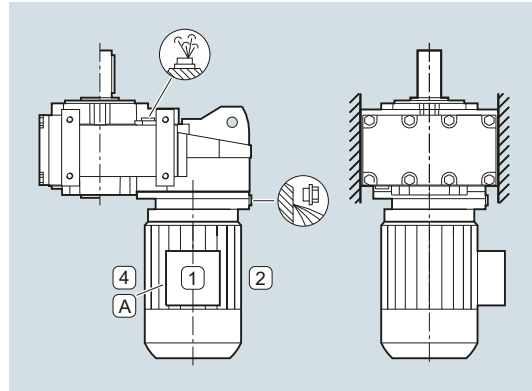

Order code:

M2

D02

M3

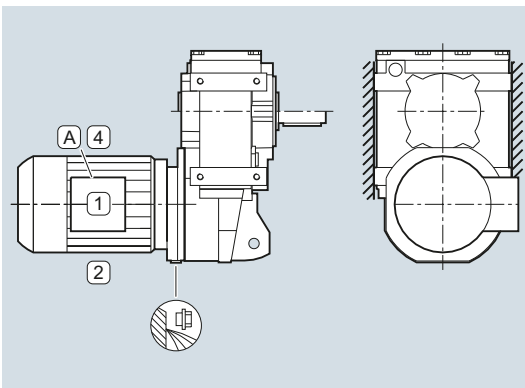

Order code:

M3

D03

M4

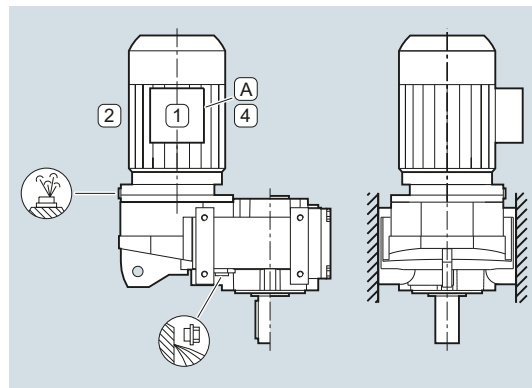

Order code:

M4

D04

M5

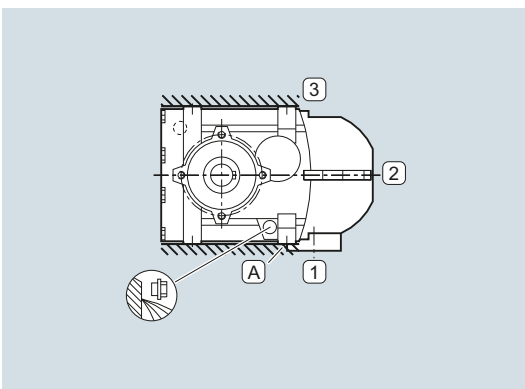

Order code:

M5

D05

M6

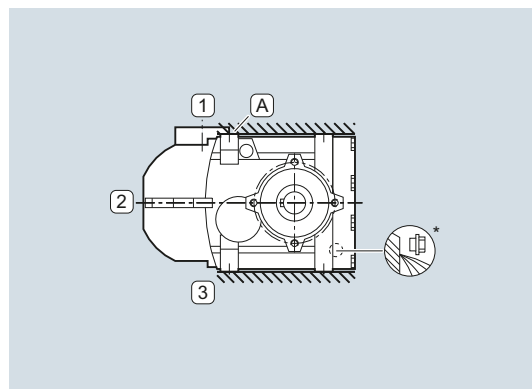

Order code:

M6

D06

Gearbox options

Mounting position

Parallel shaft gearboxes

Foot-mounted design (continued)

Parallel shaft gearboxes F, sizes 39 to 189

Oil valves

M1

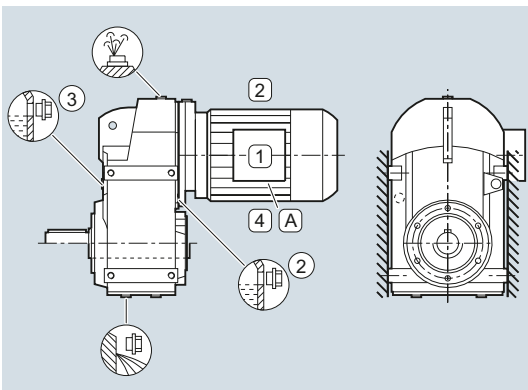

Order code:

M1

D01

M2

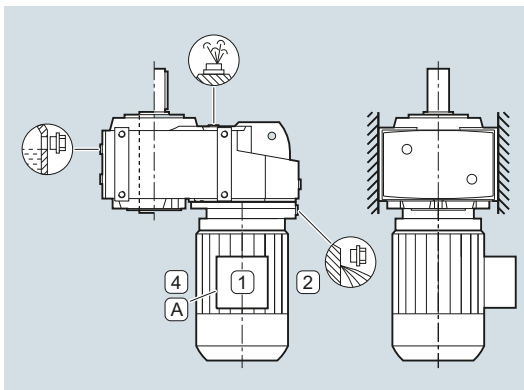

Order code:

M2

D02

M3

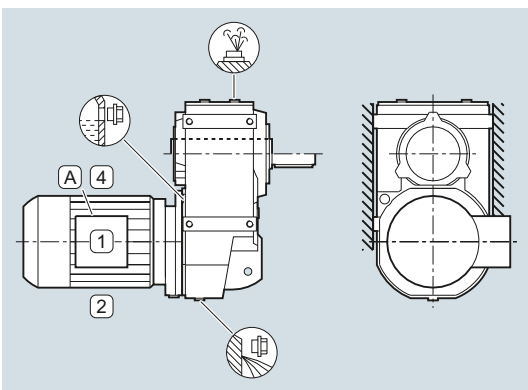

Order code:

M3

D03

M4

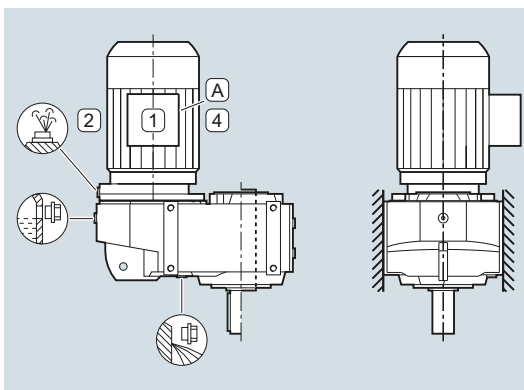

Order code:

M4

D04

M5

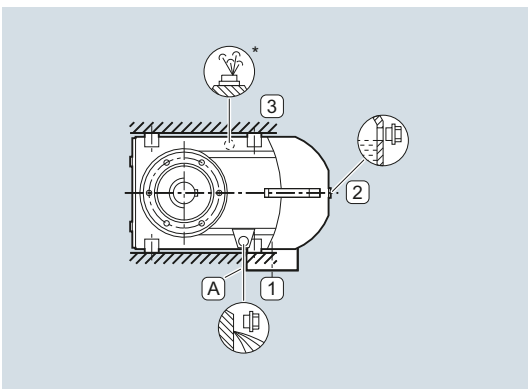

Order code:

M5

D05

M6

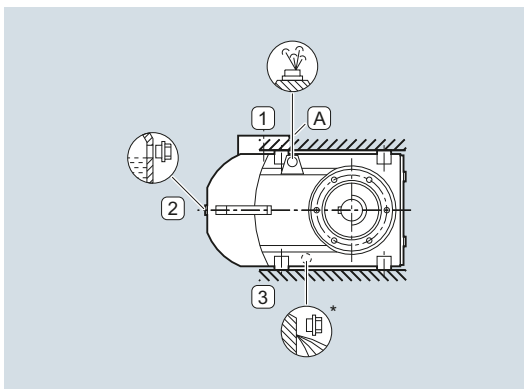

Order code:

M6

D06

Foot-mounted design

Bevel gearboxes B, size 29

Oil valves

Sizes 19 and 29 are lubricated for life.

M1

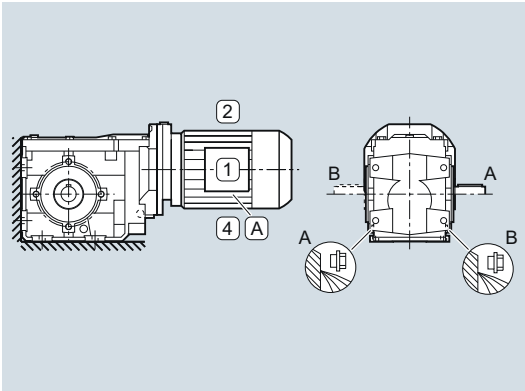

Order code:

M1 output side A

D11

M1 output side B

D21

M2

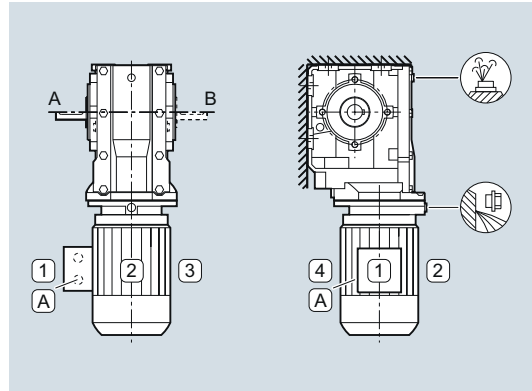

Order code:

M2 output side A

D12

M2 output side B

D22

M3

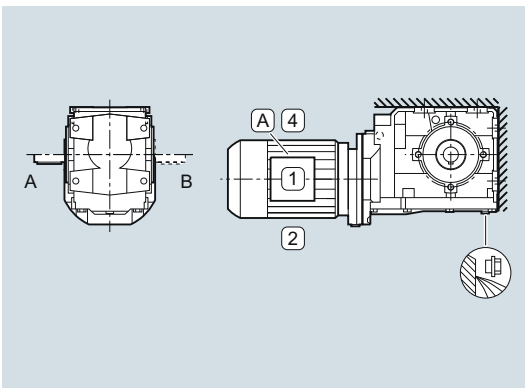

Order code:

M3 output side A

D13

M3 output side B

D23

M4

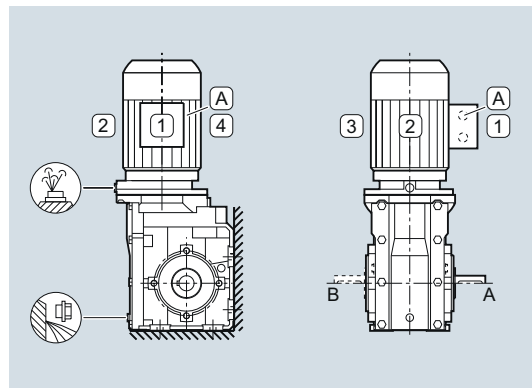

Order code:

M4 output side A

D14

M4 output side B

D24

M5

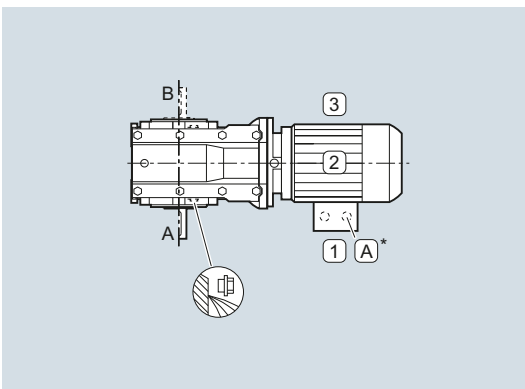

Order code:

M5 output side A

D15

M5 output side B

D25

M6

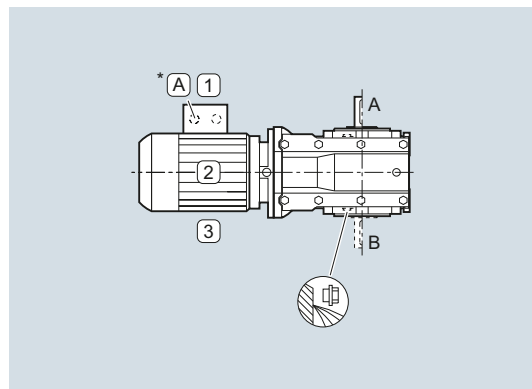

Order code:

M6 output side A

D16

M6 output side B

D26

Gearbox options

Mounting position

Bevel gearbox B

Foot-mounted design (continued)

Bevel gearboxes B, sizes 39 and 49

Oil valves

M1

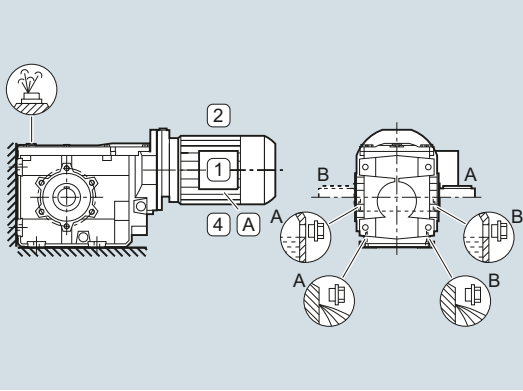

Order code:

M1 output side A

M1 output side B

D11

D21

M2

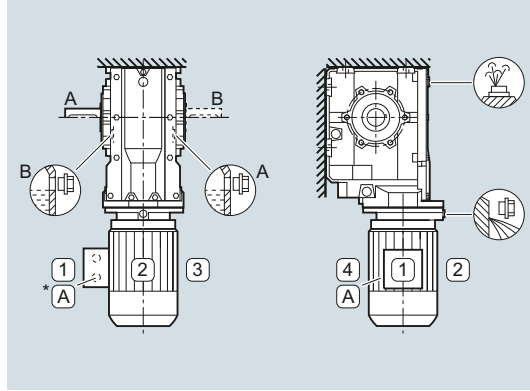

Order code:

M2 output side A

M2 output side B

D12

D22

M3

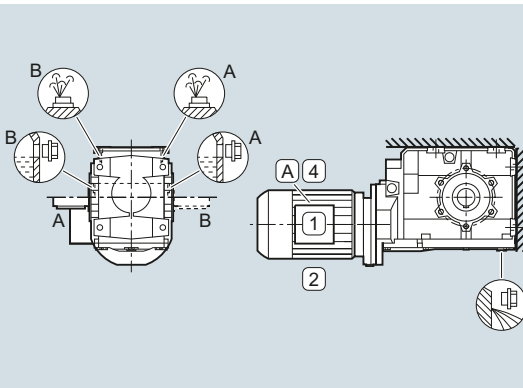

Order code:

M3 output side A

M3 output side B

D13

D23

M4

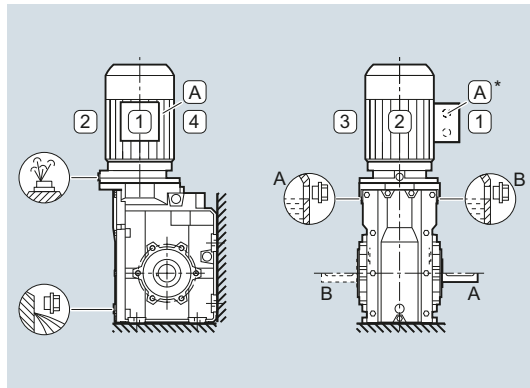

Order code:

M4 output side A

M4 output side B

D14

D24

M5

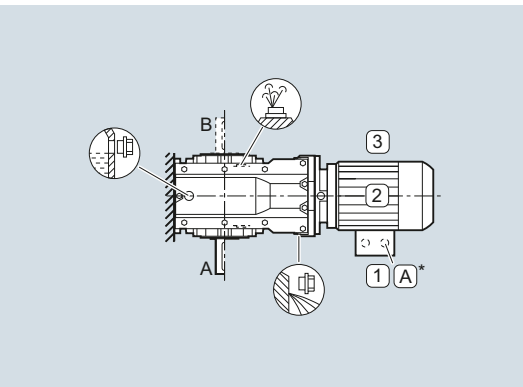

Order code:

M5 output side A

M5 output side B

D15

D25

M6

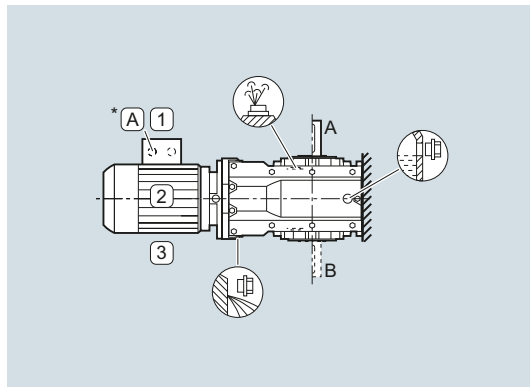

Order code:

M6 output side A

M6 output side B

D16

D26

Housing flange design and flange-mounted design

Bevel gearboxes B.Z and B.F, size 29

Oil valves

Sizes 19 and 29 are lubricated for life.

M1

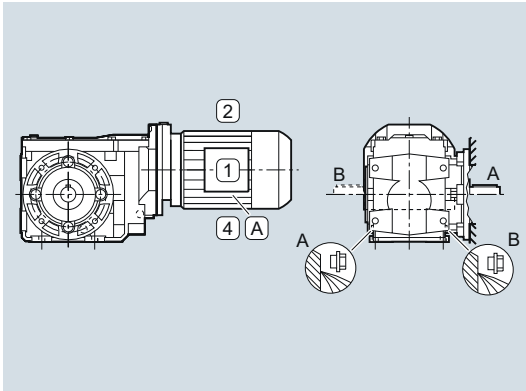

Order code:

M1 output side A

D11

M1 output side B

D21

M2

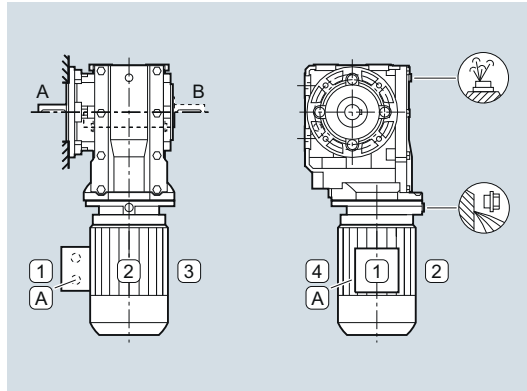

Order code:

M2 output side A

D12

M2 output side B

D22

M3

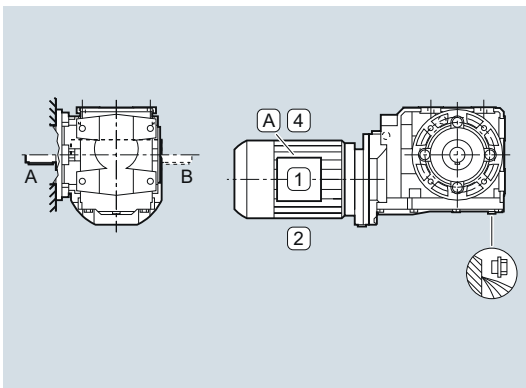

Order code:

M3 output side A

D13

M3 output side B

D23

M4

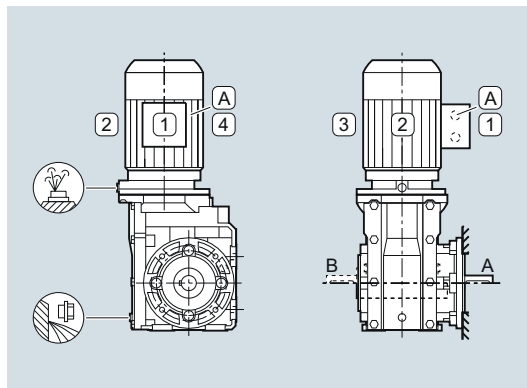

Order code:

M4 output side A

D14

M4 output side B

D24

M5

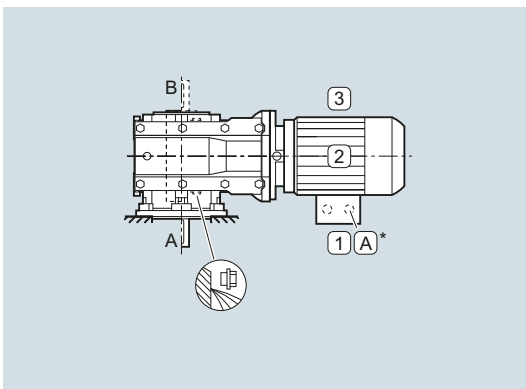

Order code:

M5 output side A

D15

M5 output side B

D25

M6

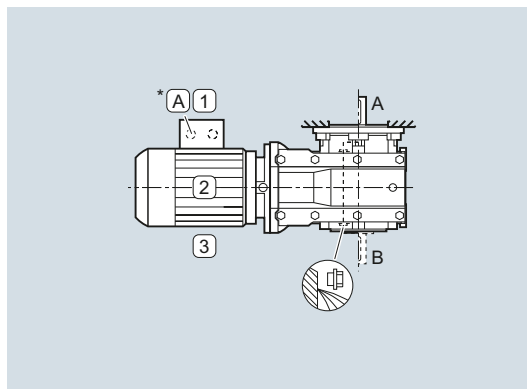

Order code:

M6 output side A

D16

M6 output side B

D26

Gearbox options

Mounting position

Bevel gearbox B

Housing flange design and flange-mounted design (continued)

Bevel gearboxes B.Z and B.F, sizes 39 and 49

Oil valves

M1

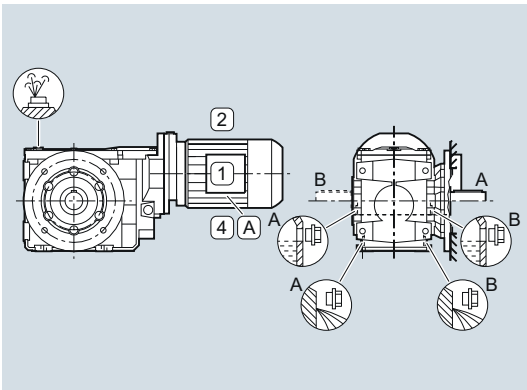

Order code:

M1 output side A

M1 output side B

D11

D21

M2

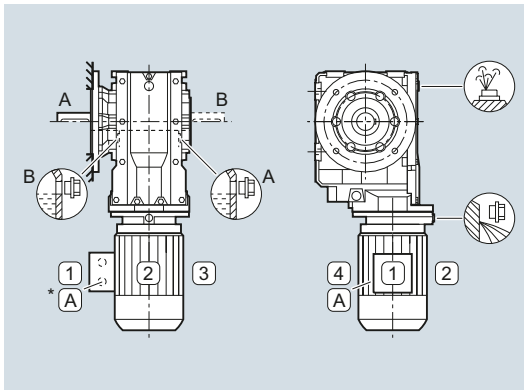

Order code:

M2 output side A

M2 output side B

D12

D22

M3

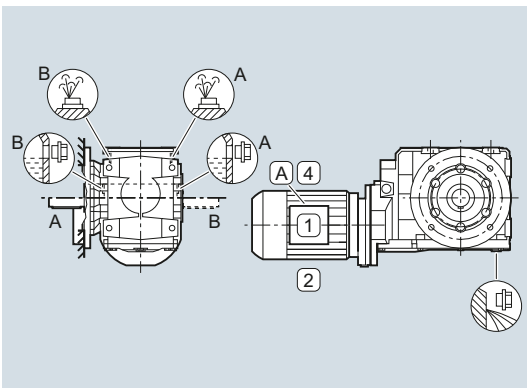

Order code:

M3 output side A

M3 output side B

D13

D23

M4

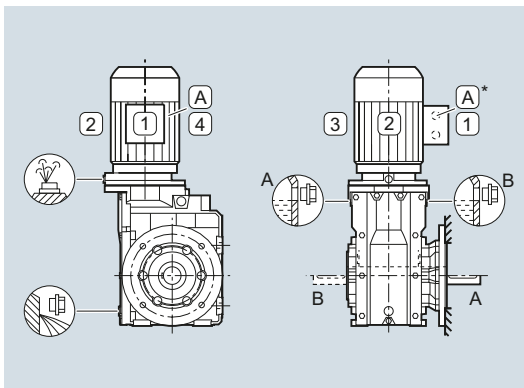

Order code:

M4 output side A

M4 output side B

D14

D24

M5

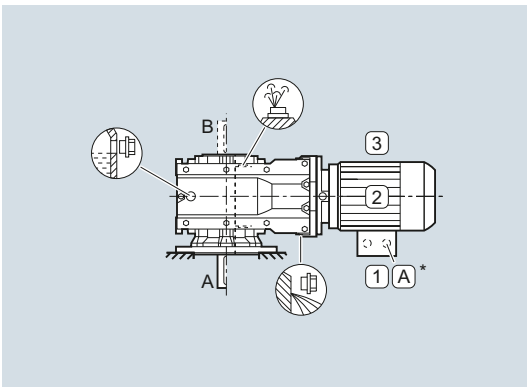

Order code:

M5 output side A

M5 output side B

D15

D25

M6

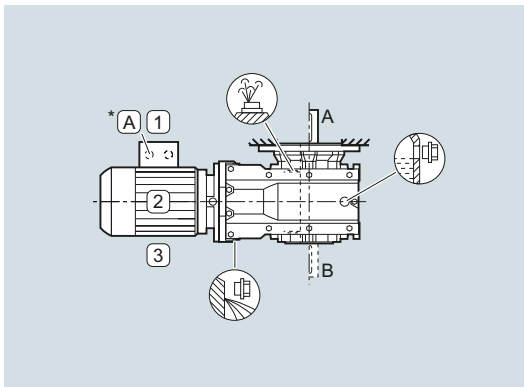

Order code:

M6 output side A

M6 output side B

D16

D26

Shaft-mounted design

Bevel gearboxes BAD, size 29

Oil valves

Sizes 19 and 29 are lubricated for life.

M1

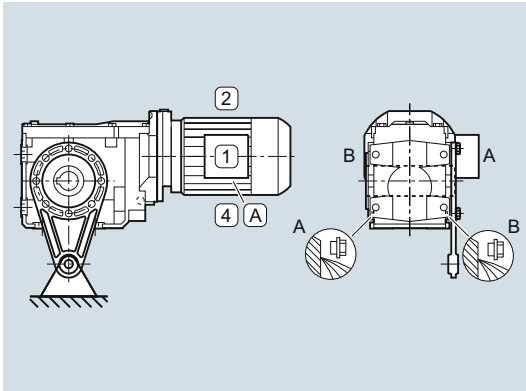

Order code:

M1 output side A

D11

M1 output side B

D21

M2

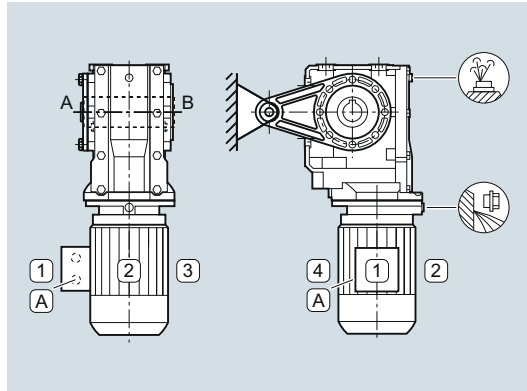

Order code:

M2 output side A

D12

M2 output side B

D22

M3

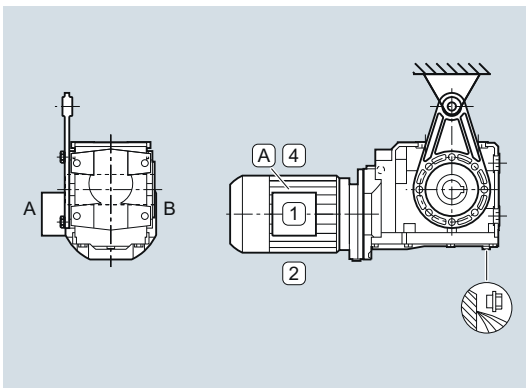

Order code:

M3 output side A

D13

M3 output side B

D23

M4

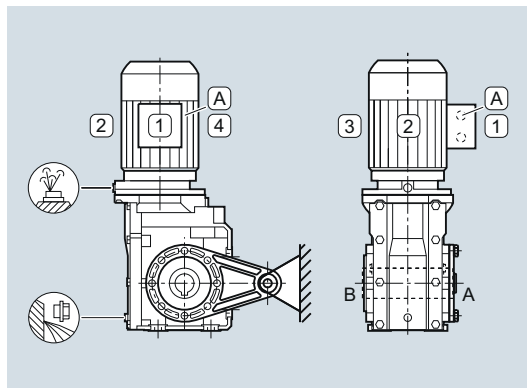

Order code:

M4 output side A

D14

M4 output side B

D24

M5

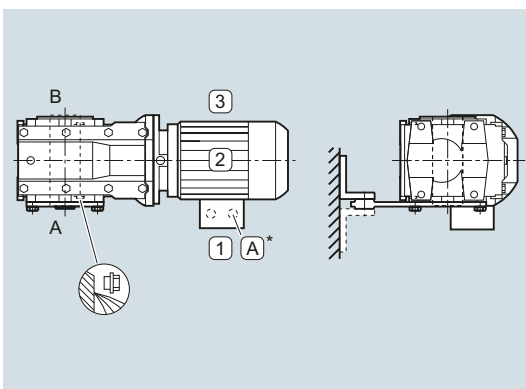

Order code:

M5 output side A

D15

M5 output side B

D25

M6

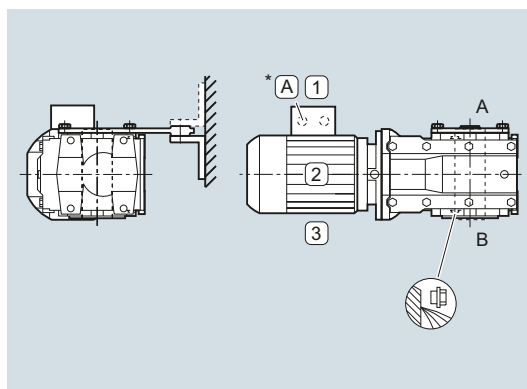

Order code:

M6 output side A

D16

M6 output side B

D26

Gearbox options

Mounting position

Bevel gearbox B

Shaft-mounted design (continued)

Bevel gearboxes BAD, sizes 39 and 49

Oil valves

M1

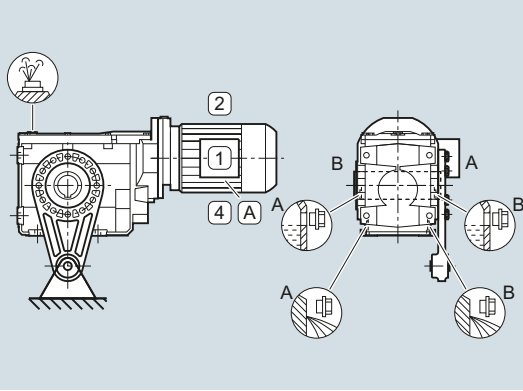

Order code:

M1 output side A

M1 output side B

D11

D21

M2

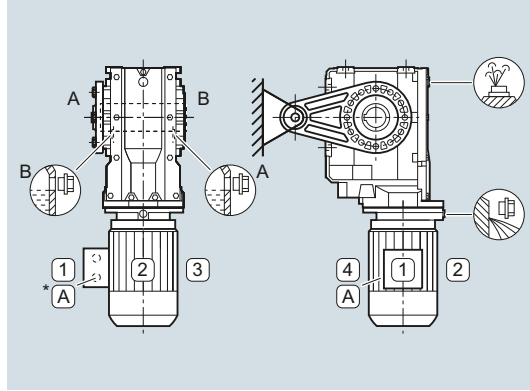

Order code:

M2 output side A

M2 output side B

D12

D22

M3

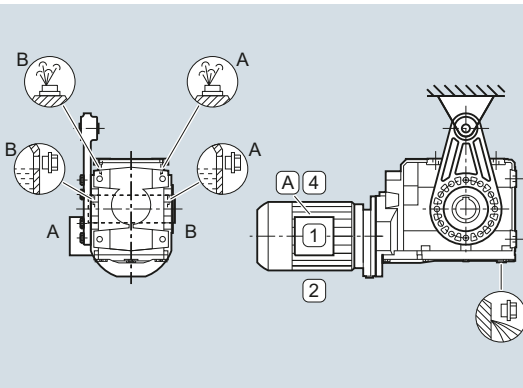

Order code:

M3 output side A

M3 output side B

D13

D23

M4

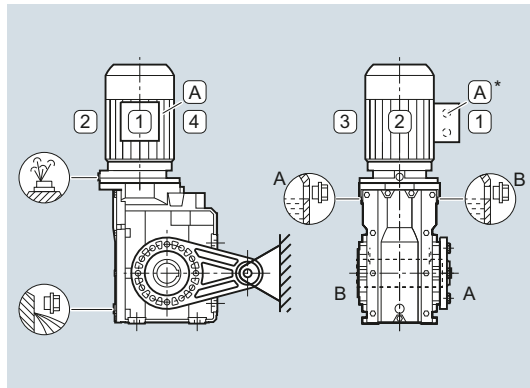

Order code:

M4 output side A

M4 output side B

D14

D24

M5

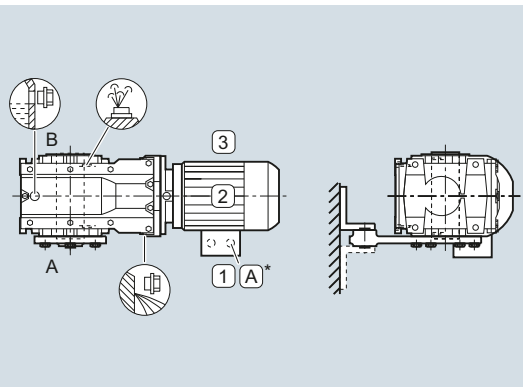

Order code:

M5 output side A

M5 output side B

D15

D25

M6

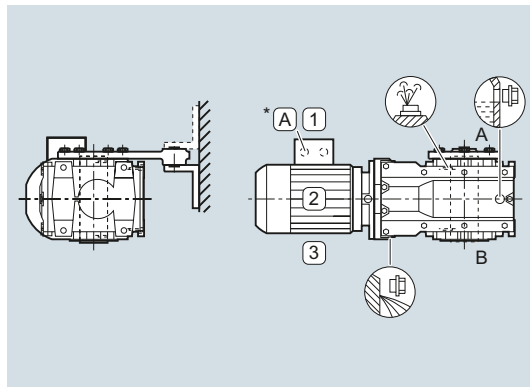

Order code:

M6 output side A

M6 output side B

D16

D26

Foot-mounted design

Bevel gearboxes K, sizes 39 to 189

Oil valves

M1

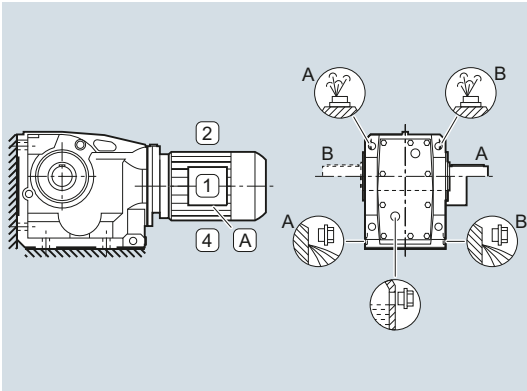

Order code:

M1 output side A

M1 output side B

D11

D21

M2

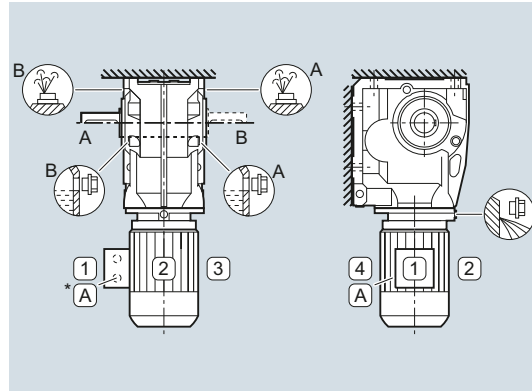

Order code:

M2 output side A

M2 output side B

D12

D22

M3

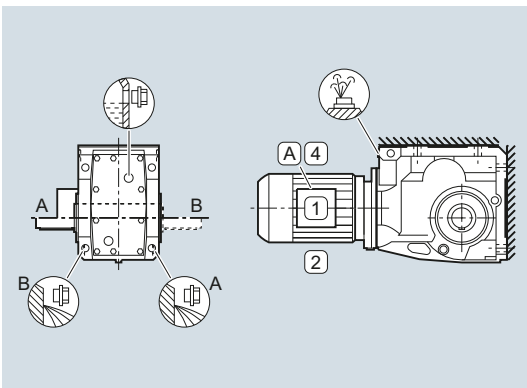

Order code:

M3 output side A

M3 output side B

D13

D23

M4

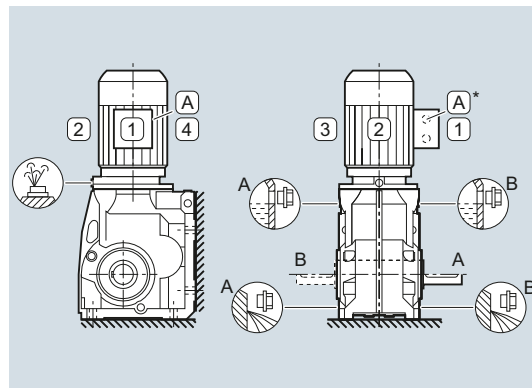

Order code:

M4 output side A

M4 output side B

D14

D24

M5

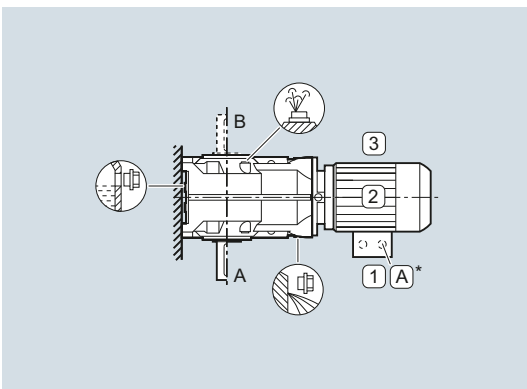

Order code:

M5 output side A

M5 output side B

D15

D25

M6

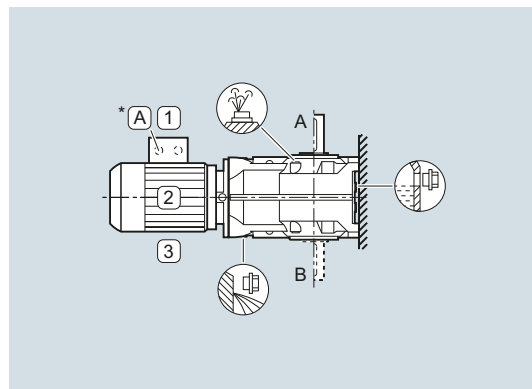

Order code:

M6 output side A

M6 output side B

D16

D26

Gearbox options

Mounting position

Bevel gearbox K

Housing flange design and flange-mounted design

Bevel gearboxes KAZ and K.F, sizes 39 to 189

Oil valves

M1

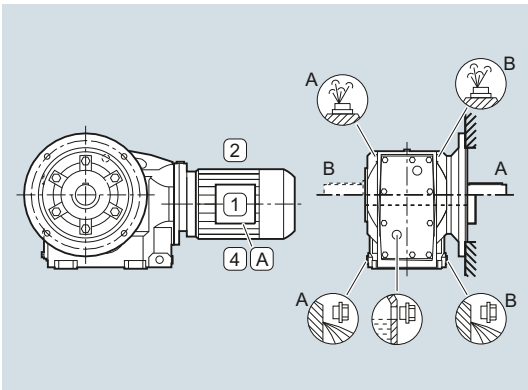

Order code:

M1 output side A

M1 output side B

D11

D21

M2

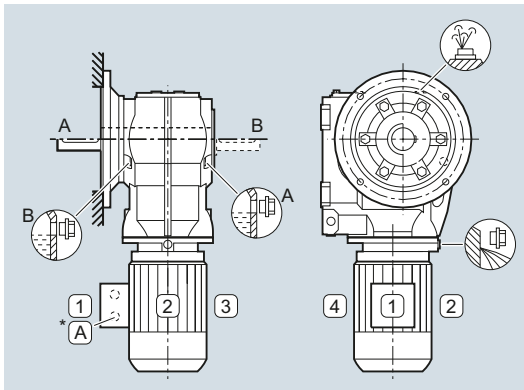

Order code:

M2 output side A

M2 output side B

D12

D22

M3

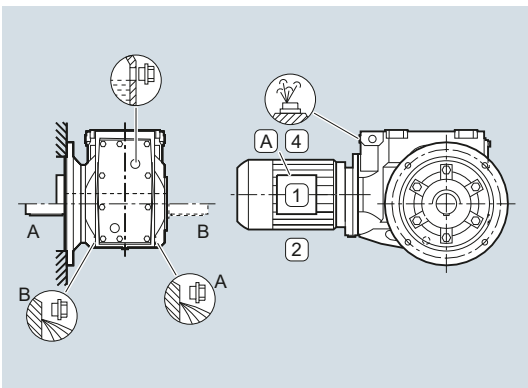

Order code:

M3 output side A

M3 output side B

D13

D23

M4

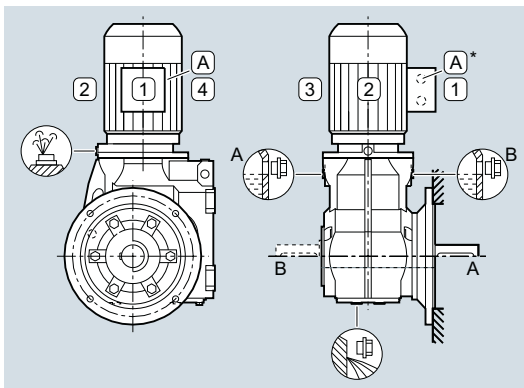

Order code:

M4 output side A

M4 output side B

D14

D24

M5

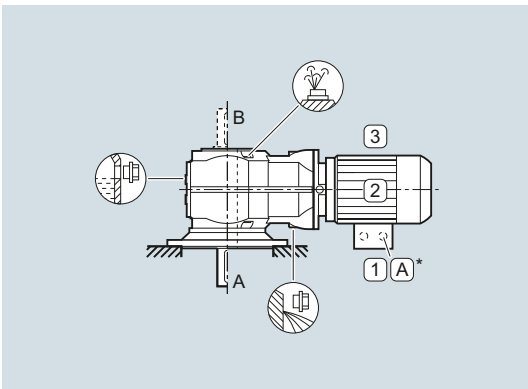

Order code:

M5 output side A

M5 output side B

D15

D25

M6

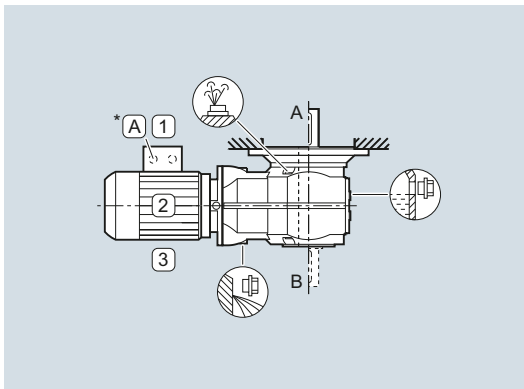

Order code:

M6 output side A

M6 output side B

D16

D26

Shaft-mounted design

Bevel gearboxes KAD, sizes 39 to 189

Oil valves

M1

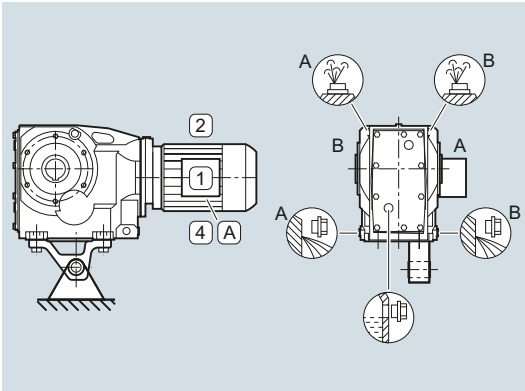

Order code:

M1 output side A

M1 output side B

D11

D21

M2

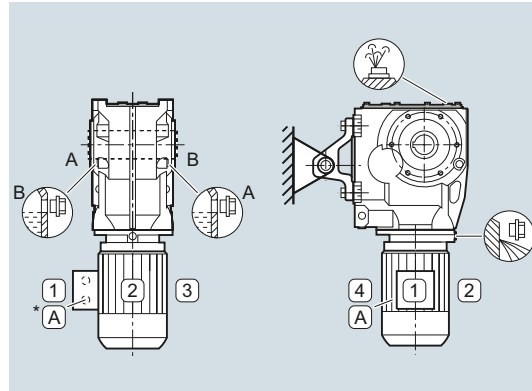

Order code:

M2 output side A

M2 output side B

D12

D22

M3

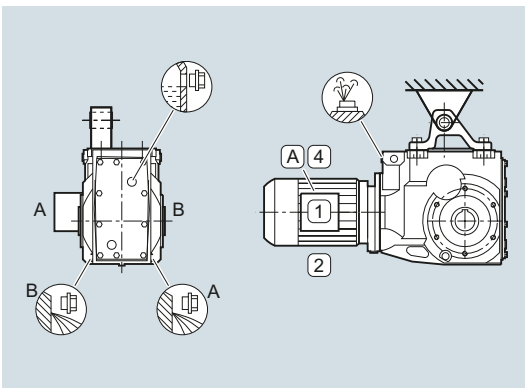

Order code:

M3 output side A

M3 output side B

D13

D23

M4

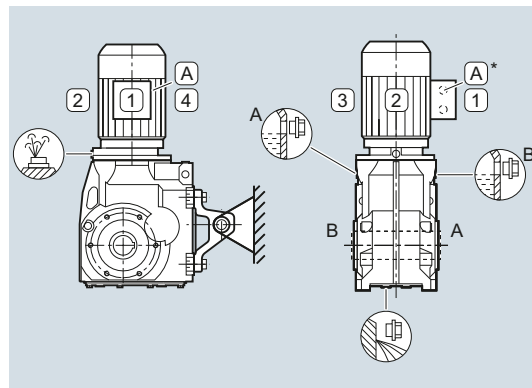

Order code:

M4 output side A

M4 output side B

D14

D24

M5

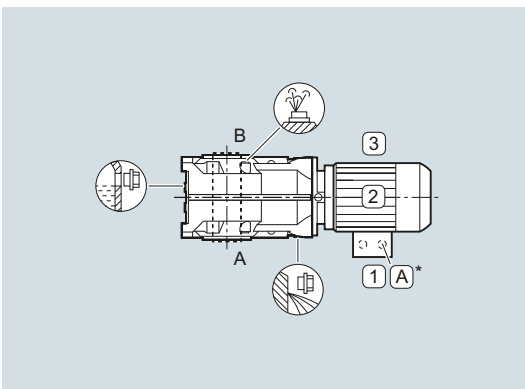

Order code:

M5 output side A

M5 output side B

D15

D25

M6

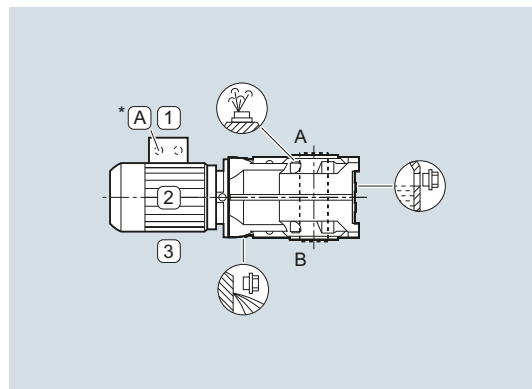

Order code:

M6 output side A

M6 output side B

D16

D26

Gearbox options

Mounting position

Helical worm gearboxes

Shaft-mounted design

Helical worm gearboxes CAD, size 29

Oil valves

Size 29 is lubricated for life.

M1

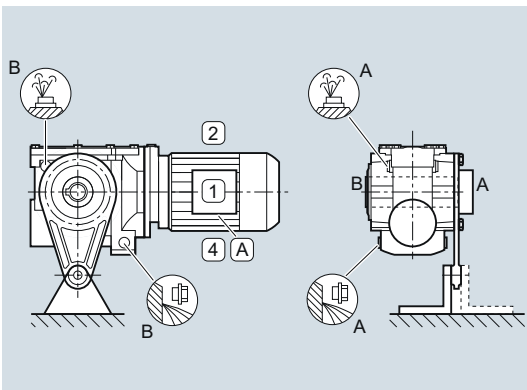

Order code:

M1 output side A

M1 output side B

D11

D21

M2

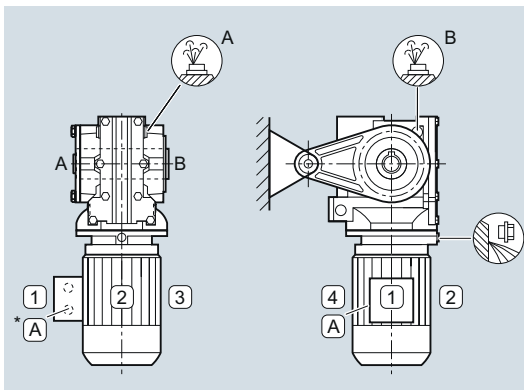

Order code:

M2 output side A

M2 output side B

D12

D22

M3

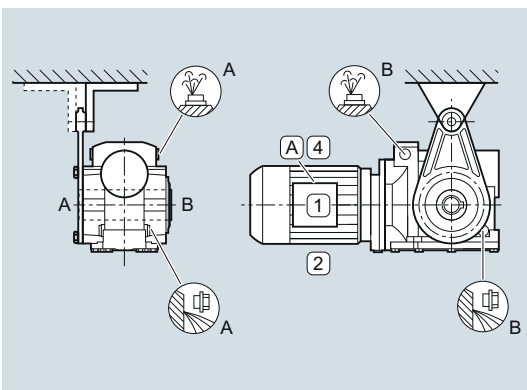

Order code:

M3 output side A

M3 output side B

D13

D23

M4

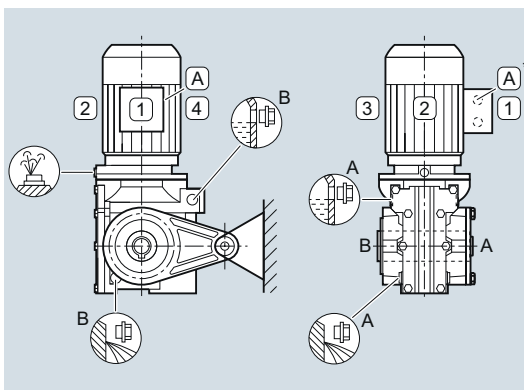

Order code:

M4 output side A

M4 output side B

D14

D24

M5

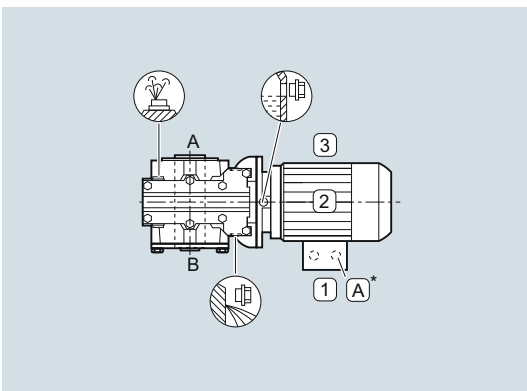

Order code:

M5 output side A

M5 output side B

D15

D25

M6

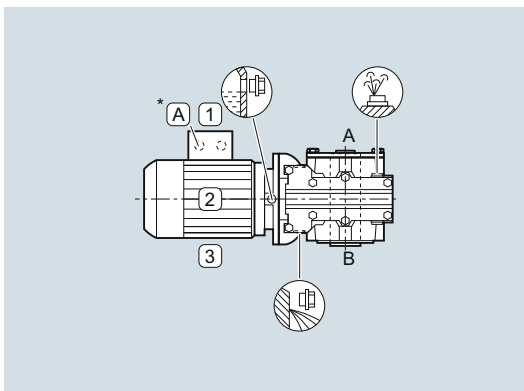

Order code:

M6 output side A

M6 output side B

D16

D26

Shaft-mounted design (continued)

Helical worm gearboxes CAD, sizes 39 to 89

Oil valves

M1

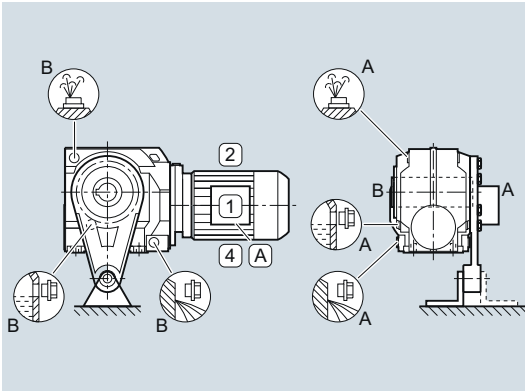

Order code:

M1 output side A

D11

M1 output side B

D21

M2

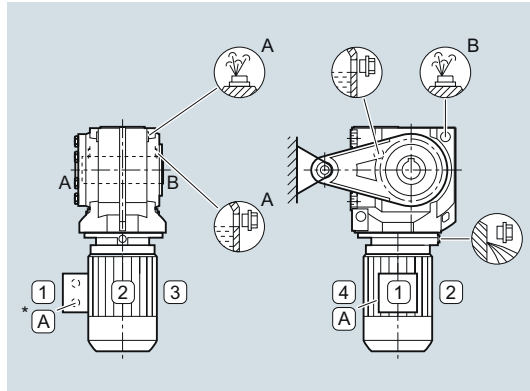

Order code:

M2 output side A

D12

M2 output side B

D22

M3

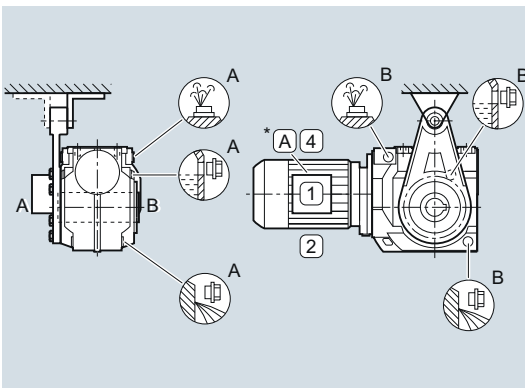

Order code:

M3 output side A

D13

M3 output side B

D23

M4

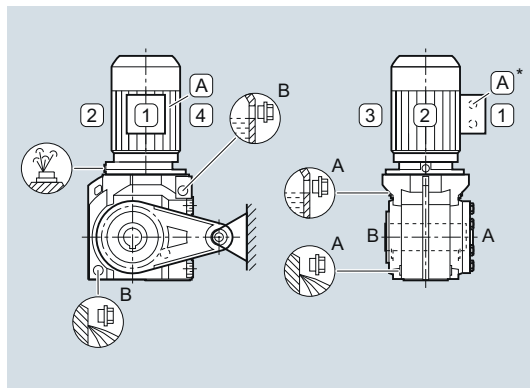

Order code:

M4 output side A

D14

M4 output side B

D24

M5

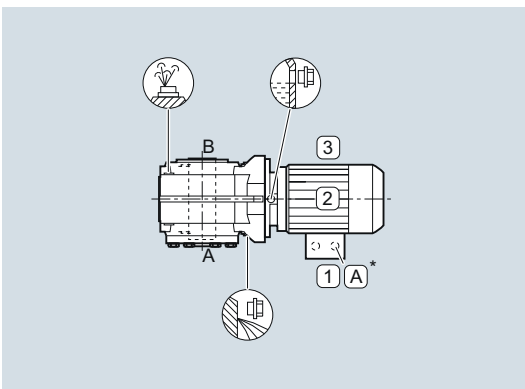

Order code:

M5 output side A

D15

M5 output side B

D25

M6

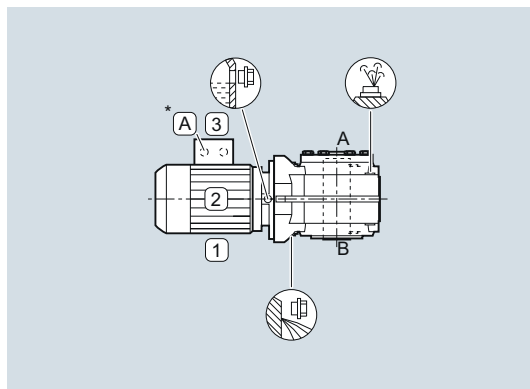

Order code:

M6 output side A

D16

M6 output side B

D26

Gearbox options

Mounting position

Helical worm gearboxes

Housing flange design and flange-mounted design

Helical worm gearboxes CAZ and C.F, size 29

Oil valves

Size 29 is lubricated for life.

M1

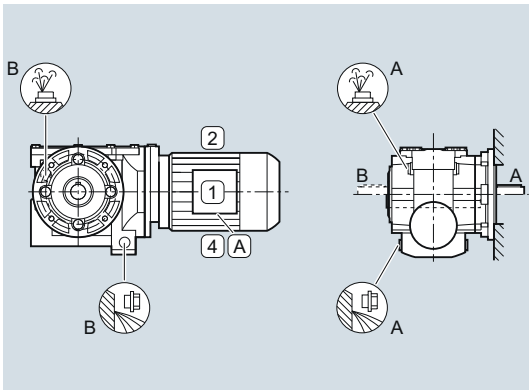

Order code:

M1 output side A

D11

M1 output side B

D21

M2

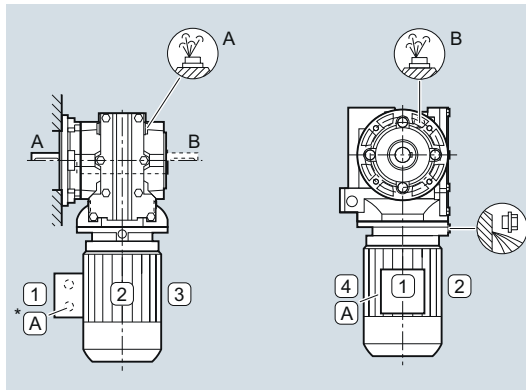

Order code:

M2 output side A

D12

M2 output side B

D22

M3

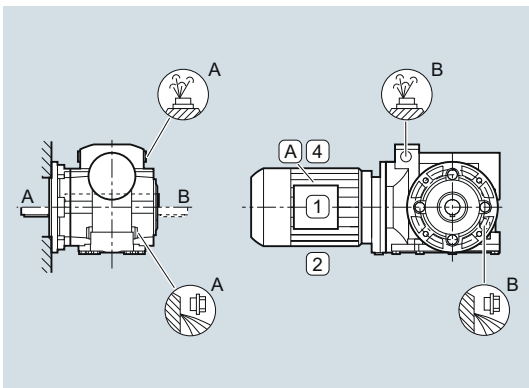

Order code:

M3 output side A

D13

M3 output side B

D23

M4

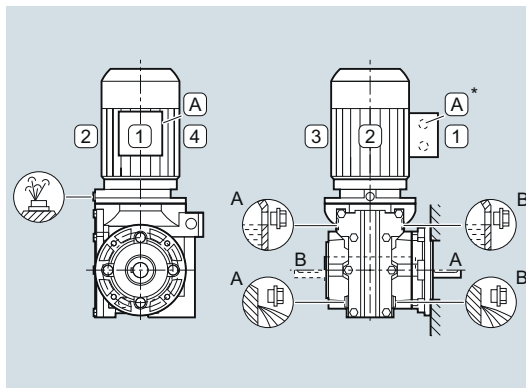

Order code:

M4 output side A

D14

M4 output side B

D24

M5

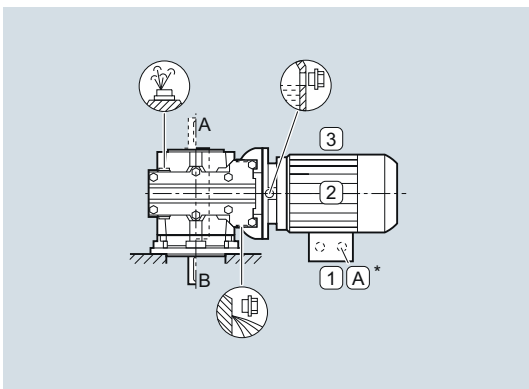

Order code:

M5 output side A

D15

M5 output side B

D25

M6

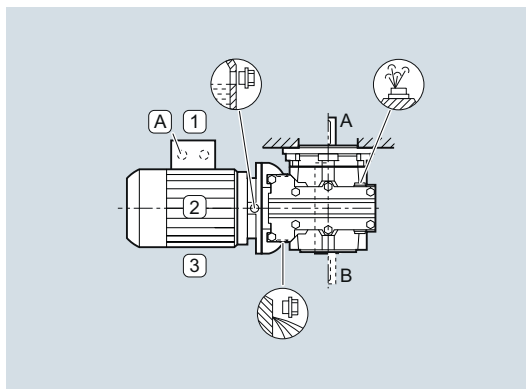

Order code:

M6 output side A

D16

M6 output side B

D26

Housing flange design and flange-mounted design (continued)

Helical worm gearboxes CAZ and C.F, sizes 39 to 89

Oil valves

M1

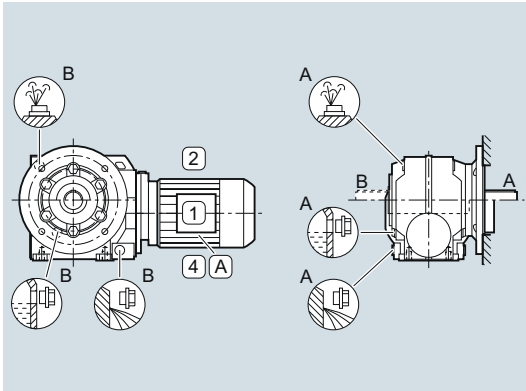

Order code:

M1 output side A

M1 output side B

D11

D21

M2

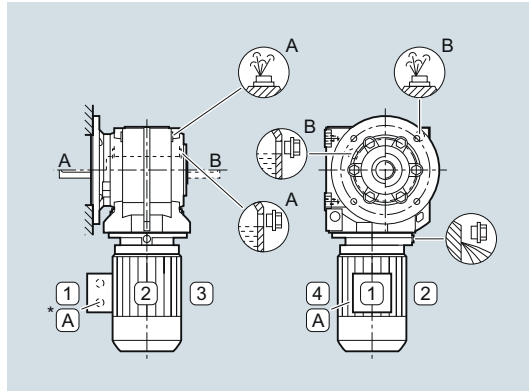

Order code:

M2 output side A

M2 output side B

D12

D22

M3

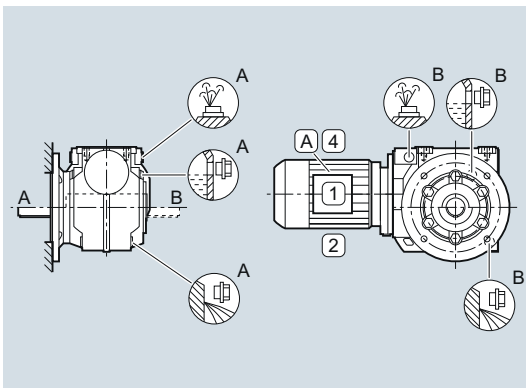

Order code:

M3 output side A

M3 output side B

D13

D23

M4

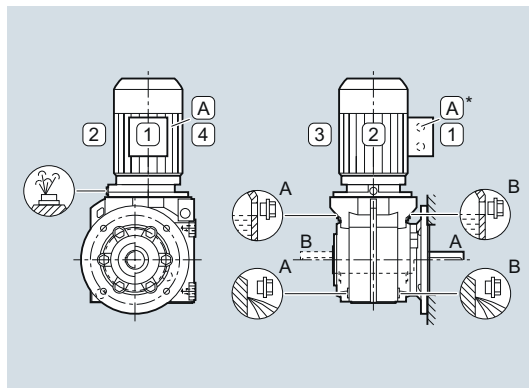

Order code:

M4 output side A

M4 output side B

D14

D24

M5

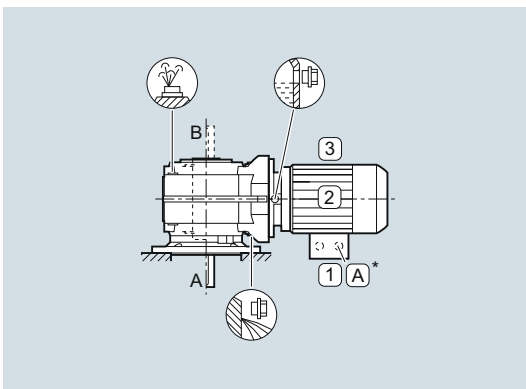

Order code:

M5 output side A

M5 output side B

D15

D25

M6

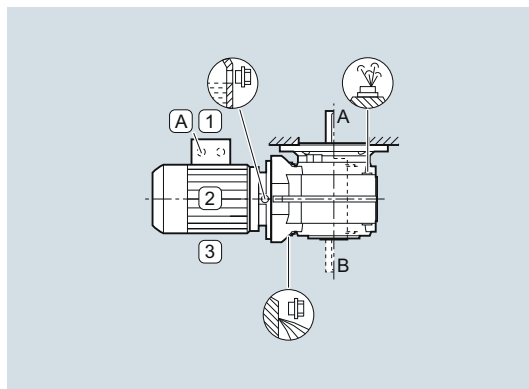

Order code:

M6 output side A

M6 output side B

D16

D26

Gearbox options

Mounting position

Helical worm gearboxes

Foot-mounted design

Helical worm gearboxes C, size 29

Oil valves

Size 29 is lubricated for life.

M1

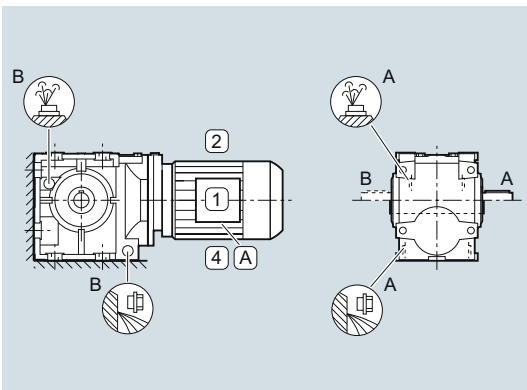

Order code:

M1 output side A

D11

M1 output side B

D21

M2

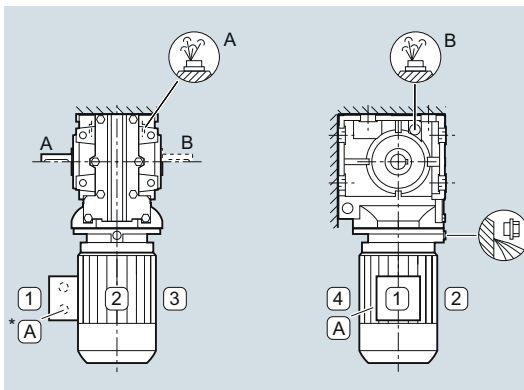

Order code:

M2 output side A

D12

M2 output side B

D22

M3

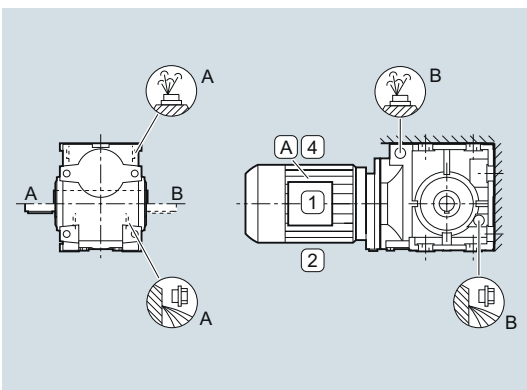

Order code:

M3 output side A

D13

M3 output side B

D23

M4

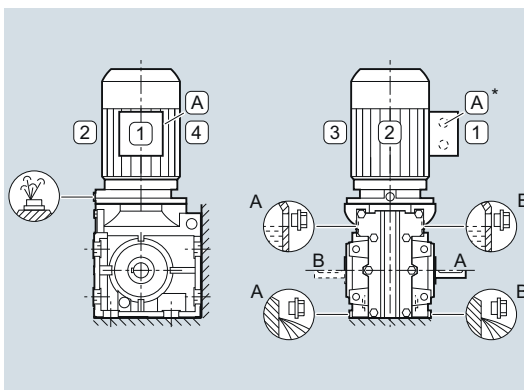

Order code:

M4 output side A

D14

M4 output side B

D24

M5

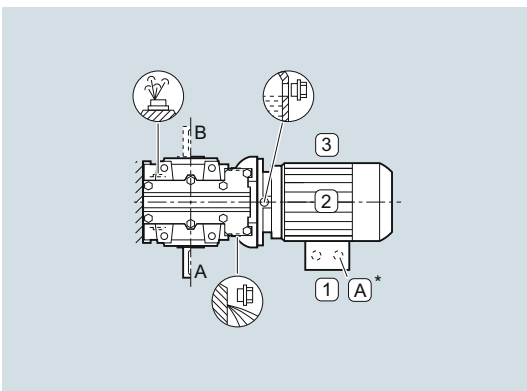

Order code:

M5 output side A

D15

M5 output side B

D25

M6

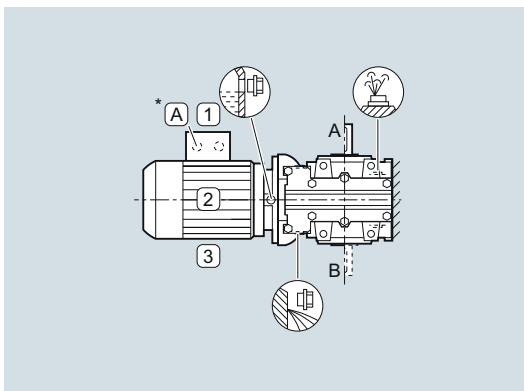

Order code:

M6 output side A

D16

M6 output side B

D26

Foot-mounted design (continued)

Helical worm gearboxes C, sizes 39 to 89

Oil valves

M1

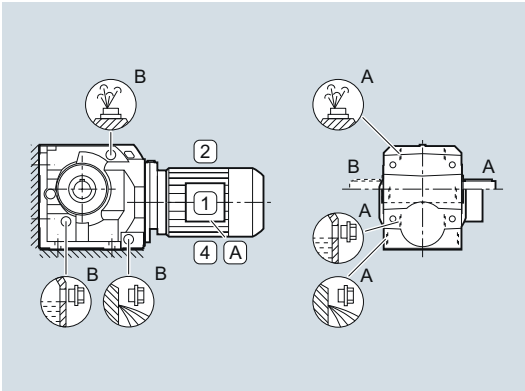

Order code:

M1 output side A

D11

M1 output side B

D21

M2

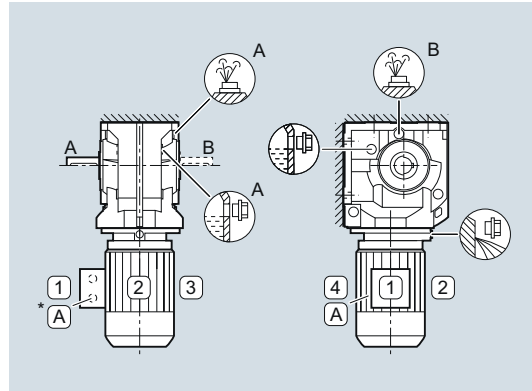

Order code:

M2 output side A

D12

M2 output side B

D22

M3

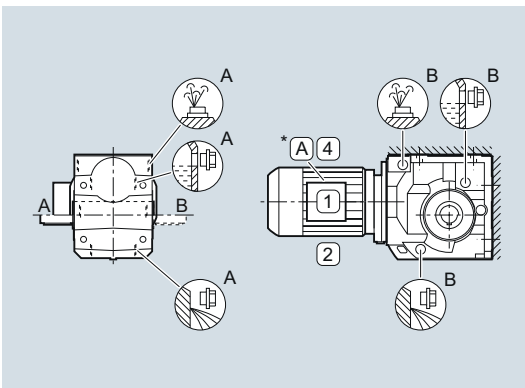

Order code:

M3 output side A

D13

M3 output side B

D23

M4

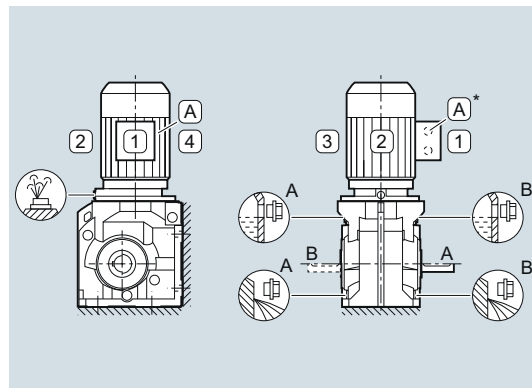

Order code:

M4 output side A

D14

M4 output side B

D24

M5

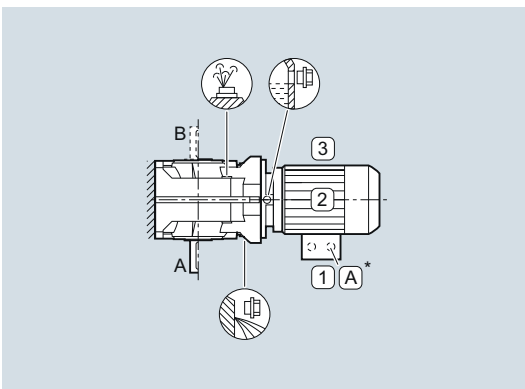

Order code:

M5 output side A

D15

M5 output side B

D25

M6

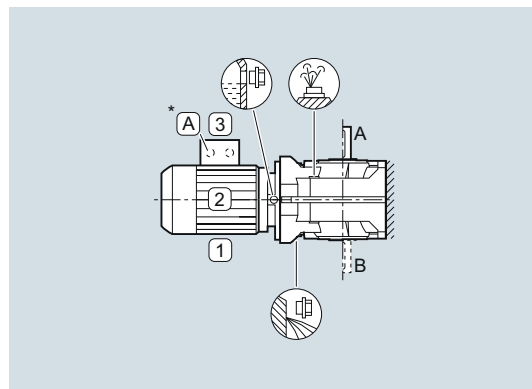

Order code:

M6 output side A

D16

M6 output side B

D26

Gearbox options

Mounting position

Worm gearbox

Foot-mounted, flange-mounted, shaft-mounted and housing flange designs

Worm gearboxes S., sizes 09 to 29

Oil valves

The worm gearboxes S are lubricated for life.

M0 is a universal mounting position in which the geared motor can be installed in any position.

M1

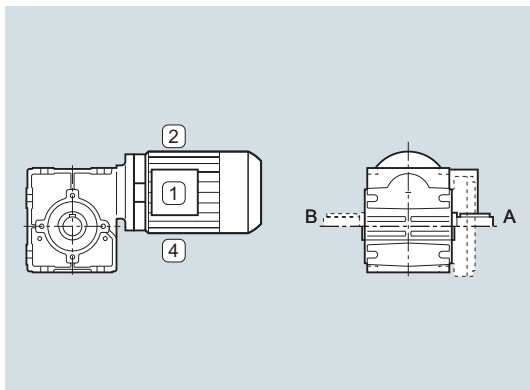

Order code:

M1 output side A

D11

M1 output side B

D21

M2

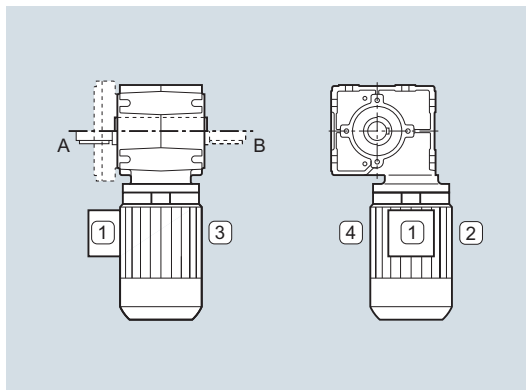

Order code:

M2 output side A

D12

M2 output side B

D22

M3

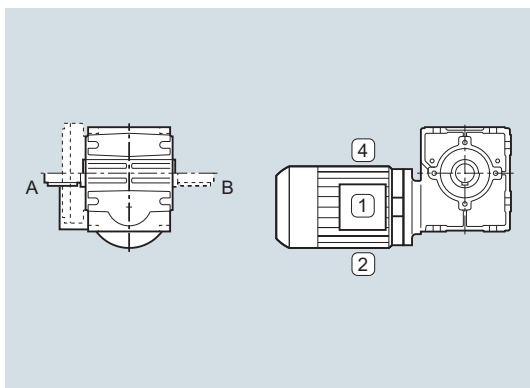

Order code:

M3 output side A

D13

M3 output side B

D23

M4

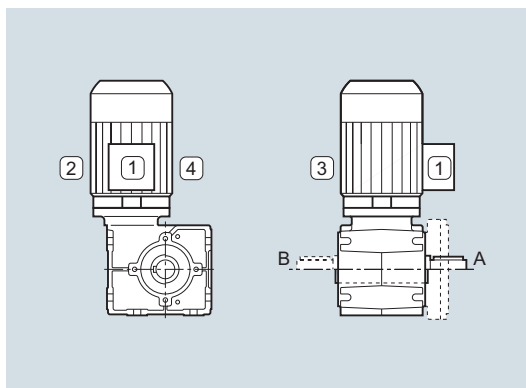

Order code:

M4 output side A

D14

M4 output side B

D24

M5

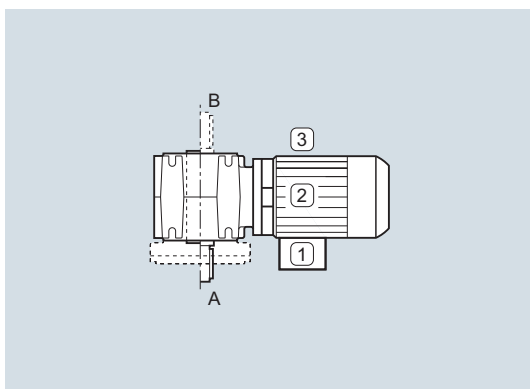

Order code:

M5 output side A

D15

M5 output side B

D25

M6

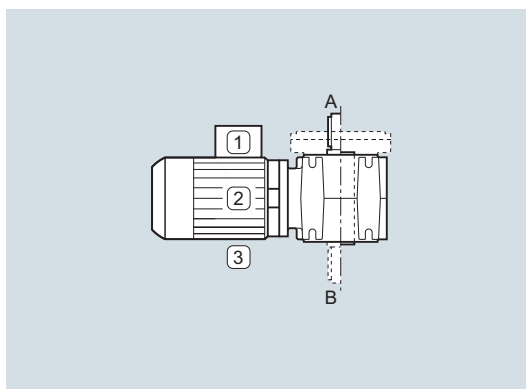

Order code:

M6 output side A

D16

M6 output side B

D26

Overview

Apart from the standard types of construction, geared motors can also be supplied in different angled positions.

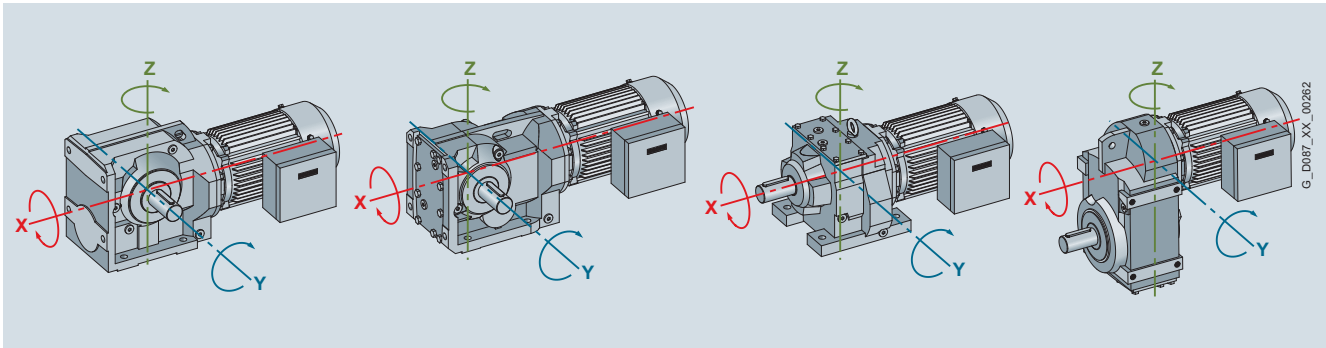

Fig. 9/6 Axes of rotation of the geared motors

Order code:

Y axis	X axis	Z axis
Rotation angle 5 °	E01	Rotation angle 5 °
Rotation angle 10 °	E02	Rotation angle 10 °
Rotation angle 15 °	E03	Rotation angle 15 °
Rotation angle 20 °	E04	Rotation angle 20 °
Rotation angle 25 °	E05	Rotation angle 25 °
Rotation angle 30 °	E06	Rotation angle 30 °
Rotation angle 35 °	E07	Rotation angle 35 °
Rotation angle 40 °	E08	Rotation angle 40 °
Rotation angle 45 °	E09	Rotation angle 45 °
Rotation angle 50 °	E10	Rotation angle 50 °
Rotation angle 55 °	E11	Rotation angle 55 °
Rotation angle 60 °	E12	Rotation angle 60 °
Rotation angle 65 °	E13	Rotation angle 65 °
Rotation angle 70 °	E14	Rotation angle 70 °
Rotation angle 75 °	E15	Rotation angle 75 °
Rotation angle 80 °	E16	Rotation angle 80 °
Rotation angle 85 °	E17	Rotation angle 85 °

Use the functions of our electronic catalog SIMOGEAR Configurator for the exact design of the special mounting position you require.

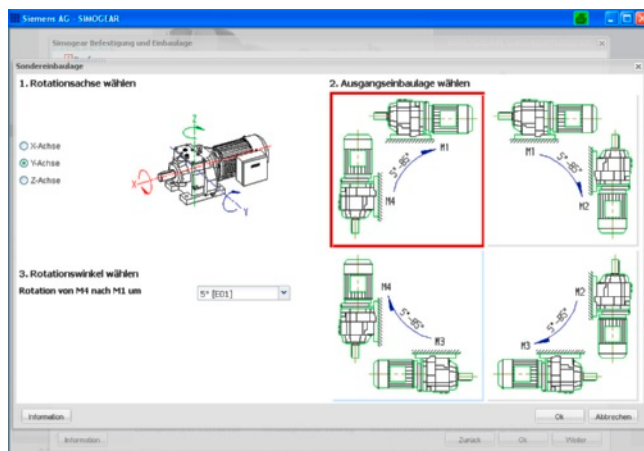

Fig. 9/7 SIMOGEAR Configurator

Gearbox options

Mounting

Mounting types

Overview

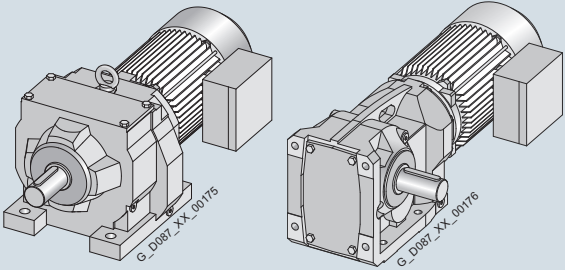
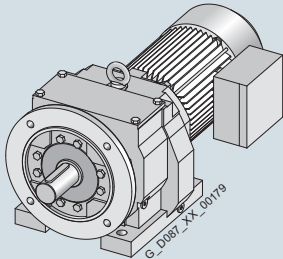
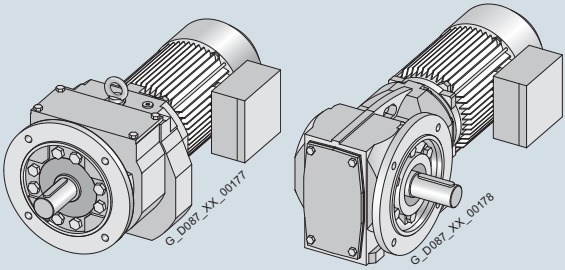
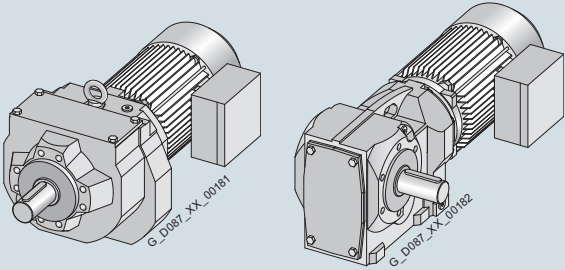
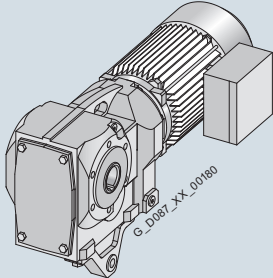
Mounting type	Type designation 2nd data position	Possible for						Example	Article No. 14th data position
		D, Z	F	B, K	C	S			
Foot-mounted design	-	✓	✓	✓	✓	✓		A	
Foot/ flange-mounted design	B	✓ ¹⁾	-	-	-	-		B	
Flange-mounted design (A type)	F	✓	✓	✓	✓	✓		F	
Housing flange (C type)	Z	✓	✓	✓	✓	✓		H	
Shaft-mounted design (torque arm)	D	-	✓	✓	✓	✓		D	

¹⁾ Only for sizes 29 to 89

Flange-mounted designs

The flange-mounted designs are available with different diameters.

Gearbox type	Flange diameter mm												Order code
Helical gearboxes DF and ZF or DB and ZB¹⁾													
Gearbox size	29	39	49	59	69	79	89	109	129	149	169	189	
	120 ²⁾	120 ²⁾											H02
	140		140 ²⁾										H03
	160	160	160	160 ²⁾									H04
		200	200	200	200 ²⁾								H05
				250	250	250 ²⁾							H06
						300	300 ²⁾						H07
							350	350	350				H08
								450	450	450	450		H09
										550	550	550	H10
												660	H11
Parallel shaft gearboxes F..F													
Gearbox size	29	39	49	69	79	89	109	129	149	169	189		
	120												H02
	160	160											H04
			200										H05
				250	250								H06
						300							H07
							350						H08
								450	450				H09
										550			H10
												660	H11
Bevel gearboxes B.F													
Gearbox size	29	39				49							
	120												H02
	160				160								H04
					200					200			H05
Bevel gearboxes K.F													
Gearbox size	39	49	69	79	89	109	129	149	169	189			
	160											H04	
		200										H05	
			250	250								H06	
					300							H07	
						350						H08	
							450	450				H09	
									550			H10	
												660	H11
Helical worm gearboxes C.F													
Gearbox size	29	39			49		69		89				
	120												H02
	160		160										H04
					200	200							H05
									250				H06
Worm gearboxes S.F													
Gearbox size	09			19			29						
	80			110			120						H01
	120 / Q90			120			160 / Q136						H02

¹⁾ Helical gearboxes in sizes 19, 109 to 189 are not available in the foot/flange-mounted design DB/ZB

²⁾ Helical gearboxes of sizes 29 to 89 in a foot/flange-mounted design DB/ZB are only available with small flange

Gearbox options

Mounting

Mounting types

Flange-mounted designs (continued)

Water drain holes at the output flange

For gearboxes in a flange-mounted design, water drain holes can be located at the output flange. This is required for mounting position M2 (output shaft facing upwards), if there is a risk that water will collect in the output flange.

Order code:

Water drain holes at the output flange

G77

Flange diameter mm	Possible for											
Helical gearboxes Z and D												
Gearbox size	29	39	49	59	69	79	89	109	129	149	169	189
120												
140			✓									
160			✓	✓ ¹⁾								
200			✓	✓	✓ ²⁾							
250				✓	✓	✓ ¹⁾						
300						✓	✓					
350							✓	✓	✓			
450								✓	✓	✓	✓	
550										✓	✓	✓
660												✓

¹⁾ Water drain holes are possible for foot/flange-mounted designs

²⁾ Water drain holes are only possible for foot/flange-mounted designs

Parallel shaft gearboxes F												
Gearbox size	29	39	49	69	79	89	109	129	149	169	189	
120												
140												
160		✓										
200			✓									
250				✓	✓							
300						✓						
350							✓					
450								✓	✓			
550										✓		
660											✓	

Bevel gearboxes K											
Gearbox size	39	49	69	79	89	109	129	149	169	189	
120											
140											
160	✓										
200		✓									
250			✓	✓							
300					✓						
350						✓					
450							✓	✓			
550									✓		
660										✓	

Parallel shaft gearboxes F.AD in a shaft-mounted design

The rubber buffers (supplied loose) are used to flexibly support the gearbox on the housing plate provided.

When mounting, the rubber buffers must be pretensioned to the dimension specified in the dimensional drawing.

The elastomer used for support is manufactured out of natural rubber $70^\circ \pm 5$ Shore A.

The rubber buffers are suitable for all mounting positions and can withstand temperatures of between -40 and $+80$ °C.

Article No. at 14th position

Shaft-mounted design

D

The dimensions of the torque arm can be seen in the dimensional drawings.

Bevel gearboxes KAD in a shaft-mounted design

The torque arm of bevel gearboxes K is mounted on the underside of the housing. The rubber buffers are used to flexibly support the gearbox on the torque arm.

The elastomer used for support is manufactured out of natural rubber 60° Shore A.

The rubber elastic buffers are suitable for all mounting positions and can withstand temperatures of between -40 and $+80$ °C.

Article No. at 14th position

Shaft-mounted design

D

The dimensions of the torque arm can be seen in the dimensional drawings.

Bevel gearboxes BAD. in a shaft-mounted design

The torque arm can be screwed to the gearbox housing at various positions.

The elastomer used for support is manufactured out of natural rubber 60° Shore A.

The rubber elastic buffers are suitable for all mounting positions and can withstand temperatures of between -40 and $+80$ °C.

Article No. at 14th position

Shaft-mounted design

D

When ordered, the torque arm is supplied loose.

Sizes BAD.19 and BAD.29**Sizes BAD.39 and BAD.49**

Fig. 9/8 Bevel gearboxes B in a shaft-mounted design

Gearbox options

Mounting

Mounting types

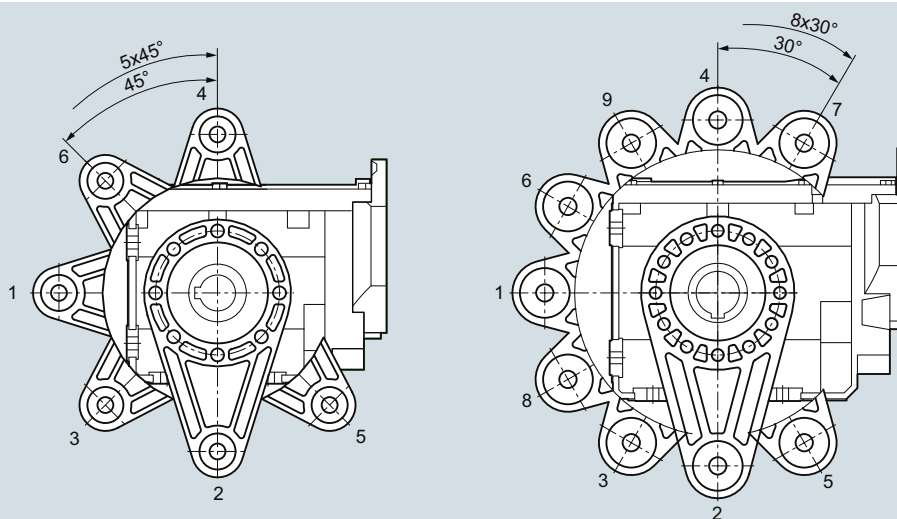
Helical worm gearboxes CAD. in a shaft-mounted design

The torque arm can be screwed to the gearbox housing at various positions.

The elastomer used for support is manufactured out of natural rubber 60° Shore A.

The rubber elastic buffers are suitable for all mounting positions and can withstand temperatures of between -40 and $+80$ °C.

Article No. at 14th position

Shaft-mounted design

D

When ordered, the torque arm is supplied loose.

Figure 1, sizes CAD.29 to CAD.89

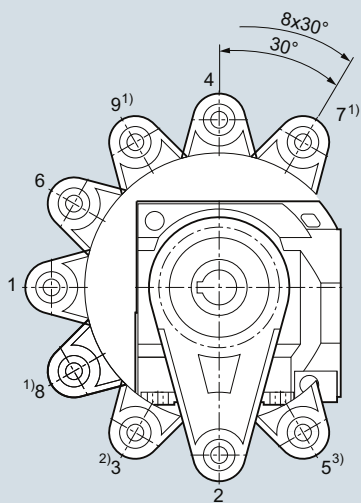

Figure 2, sizes CAD.39 to CAD.89

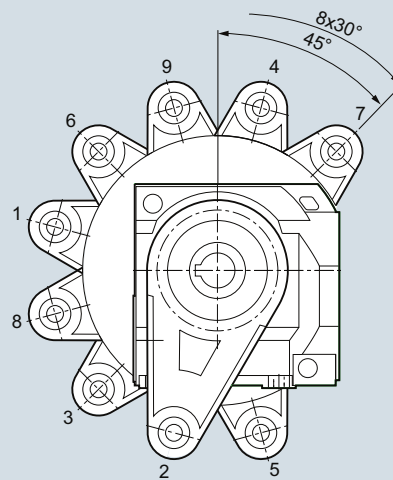

Fig. 9/9 Helical worm gearboxes C in shaft-mounted design

- 1) Position not possible for size CAD.29
- 2) Position not possible for sizes CAD.39 and CAD.69
- 3) Position not possible for size CAD.39

Order code:

Figure 1

G09

Figure 2

G10

Worm gearboxes SAD. in a shaft-mounted design

The torque arm can be screwed to the gearbox housing at various positions.

Article No. at 14th position

Shaft-mounted design

D

When ordered, the torque arm is supplied loose.

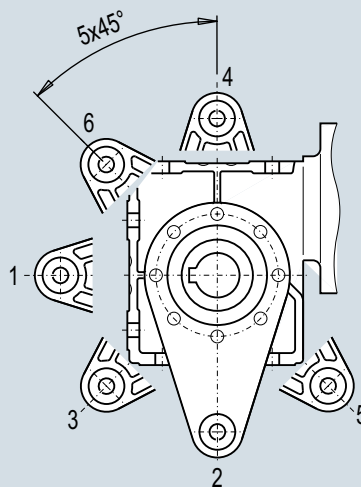

Fig. 9/10

Selection and ordering data

Shaft design	Dimensions						Article No.	Article No. suffix
	mm						8th data position	
Helical gearboxes Z and D								
Gearbox size	29	39	49	59	69	79		
Solid shaft	V25 x 50	V25 x 50	V30 x 60	V35 x 70	V35 x 70	V40 x 80	1	
Solid shaft without feather key	VG25 x 50	VG25 x 50	VG30 x 60	VG35 x 70	VG35 x 70	VG40 x 80	9	H1G
Solid shaft, inches	V1" x 1.97"	V1" x 1.97"	V1.25" x 2.36"	V1.35" x 2.76"	V1.35" x 2.76"	V1.625" x 3.15"	9	H6A
Gearbox size	89	109	129	149	169	189		
Solid shaft	V50 x 100	V60 x 120	V70 x 140	V90 x 170	V110x210	V120x210	1	
Solid shaft without feather key	VG50 x 100	-	-	-	-	-	9	H1G
Solid shaft, inches	V2.125" x 3.94"	V2.375" x 4.72"	V2.875" x 5.51"	V3.625" x 6.69"	V4.375"x8.27"	V4.75"x8.27"	9	H6A
Parallel shaft gearboxes F								
Gearbox size	29	39	49	69	79	89		
Solid shaft	V25 x 50	V25 x 50	V30 x 60	V35 x 70	V40 x 80	V50 x 100	1	
Solid shaft without feather key	VG25 x 50	VG25 x 50	VG30 x 60	VG35 x 70	VG40 x 80	VG50 x 100	9	H1G
Solid shaft, inches	V1" x 1.97"	V1" x 1.97"	V1.25" x 2.36"	V1.375" x 2.76"	V1.625" x 3.15"	V2" x 3.94"	9	H6A
Hollow shaft	H25	H30	H35	H40	H40	H50	5	
Hollow shaft, inches	H1"	H1.25"	H1.375"	H1.5"	H1.5"	H2"	9	H7A
Hollow shaft with shrink disk	HS25	HS30	HS35	HS40	HS40	HS50	9	H3A
SIMOLOC assembly system, metric	HF25	HF30	HF35	HF40	HF40	HF50	9	H3G
	HF20	HF25	HF30	HF35	HF35	HF40	9	H3H
SIMOLOC assembly system, imperial dimensions	HF1.0"	HF1.25"	HF1.375"	HF1.5"	HF1.5"	HF2.0"	9	H3J
	HF0.75"	HF1.1875"	HF1.4375"	HF1.625"	HF1.625"	HF1.9375"	9	H3K
	-	HF1.0"	HF1.25"	HF1.4375"	HF1.4375"	HF1.75"	9	H3L
	-	-	HF1.1875"	HF1.375"	HF1.375"	HF1.625"	9	H3M
Splined hollow shaft	-	N30	N35	N35	N45	N50	9	H4A
Gearbox size	109	129	149	169	189			
Solid shaft	V60 x 120	V70 x 140	V90 x 170	V110x120	V120x210		1	
Solid shaft, inches	V2.375" x 4.72"	V2.875" x 5.51"	V3.625" x 6.69"	V4.375"x8.27"	V4.75"x8.27"		9	H6A
Hollow shaft	H60	H70	H90	H100	H120		5	
Hollow shaft, inches	H2.375"	H2.75"	H3.625"	H4"	H4.5"		9	H7A
Hollow shaft with shrink disk	HS65	HS75	HS95	HS105	HS125		9	H3A
Splined hollow shaft	N65	N70	N85	N90	N110		9	H4A
Bevel gearboxes B								
Gearbox size	29	39		49				
Solid shaft	V20 x 40	V30 x 60		V35 x 70			1	
Solid shaft without feather key	VG20 x 40	VG30 x 60		VG35 x 70			9	H1G
Solid shaft, inches	V0.75" x 1.57"	V1" x 1.97"		V1.375" x 2.76"			9	H6A
Solid shaft, both ends	VD20 x 40	VD30 x 60		VD35 x 70			9	H5A
Hollow shaft	H20	H30		H40			5	
	H25	H35		H35			6	
	-	H40		-			7	
Hollow shaft, inches	H0.75"	H1.25"		H1.5"			9	H7A
Hollow shaft with shrink disk	HS20	HS35		HS40			9	H3A
SIMOLOC assembly system, metric	HF25	HF30		HF35			9	H3G
	HF20	HF25		HF30			9	H3H
	-	-		HF40			9	H3I
SIMOLOC assembly system, imperial dimensions	HF1.0"	HF1.25"		HF1.375"			9	H3J
	HF0.75"	HF1.1875"		HF1.4375"			9	H3K
	-	HF1.0"		HF1.25"			9	H3L
	-	-		HF1.1875"			9	H3M
	-	-		HF1.625"			9	H3I

Gearbox options

Mounting

Shaft designs

Selection and ordering data (continued)

Shaft design	Dimensions					Article No.	Article No. suffix
	mm					8th data position	
Bevel gearboxes K							
Gearbox size	39	49	69	79	89		
Solid shaft	V25 x 50	V30 x 60	V35 x 70	V40 x 80	V50 x 100	1	
Solid shaft without feather key	VG25 x 50	VG30 x 60	VG35 x 70	VG40 x 80	VG50 x 100	9	H1G
Solid shaft, inches	V1" x 1.97"	V1.25" x 2.36"	V1.375" x 2.76"	V1.625" x 3.15"	V2" x 3.94"	9	H6A
Solid shaft, both ends	VD25 x 50	VD30 x 60	VD35 x 70	VD40 x 80	VD50 x 100	9	H5A
Hollow shaft	H30	H35	H40	H40	H50	5	
Hollow shaft, inches	H1.25"	H1.375"	H1.5"	H1.5"	H2"	9	H7A
Hollow shaft with shrink disk	HS30	HS35	HS40	HS40	HS50	9	H3A
SIMOLOC assembly system, metric	HF30	HF35	HF40	HF40	HF50	9	H3G
	HF25	HF30	HF35	HF35	HF40	9	H3H
SIMOLOC assembly system, imperial dimensions	HF1.25"	HF1.375"	HF1.5"	HF1.5"	HF2.0"	9	H3J
	HF1.1875"	HF1.4375"	HF1.625"	HF1.625"	HF1.9375"	9	H3K
	HF1.0"	HF1.25"	HF1.4375"	HF1.4375"	HF1.75"	9	H3L
	-	HF1.1875"	HF1.375"	HF1.375"	HF1.625"	9	H3M
Splined hollow shaft	N30	N35	N35	N45	N50	9	H4A
Gearbox size	109	129	149	169	189		
Solid shaft	V60 x 120	V70 x 140	V90 x 170	V110x210	V120x210	1	
Solid shaft, inches	V2.375" x 4.72"	V2.875" x 5.51"	V3.625" x 6.69"	V4.375" x 8.27"	V4.5" x 8.27"	9	H6A
Solid shaft, both ends	VD60 x 120	VD70 x 140	VD90 x 170	VD110 x 210	VD120 x 210	9	H5A
Hollow shaft	H60	H70	H90	H100	H120	5	
Hollow shaft, inches	H2.375"	H2.75"	H3.625"	H4"	H4.5"	9	H7A
Hollow shaft with shrink disk	HS65	HS75	HS95	HS105	HS125	9	H3A
Splined hollow shaft	N65	N70	N85	N90	N110	9	H4A
Helical worm gearboxes C							
Gearbox size	29	39	49	69	89		
Solid shaft	V20 x 40	V25 x 50	V30 x 60	V35 x 70	V45 x 90	1	
Solid shaft without feather key	VG20 x 40	VG25 x 50	VG30 x 60	VG35 x 70	VG45 x 90	9	H1G
Solid shaft, inches	V0.75" x 1.57"	V1" x 1.97"	V1.25" x 2.36"	V1.375" x 2.76"	V1.75" x 3.15"	9	H6A
Solid shaft, both ends	VD20 x 40	VD25 x 50	VD30 x 60	VD35 x 70	VD45 x 90	9	H5A
Hollow shaft	H20	H25	H30	H40	H50	5	
	-	H30	H35	H45	H60	6	
Hollow shaft, inches	H0.75"	H1.25"	H1.375"	H1.5"	H2"	9	H7A
Hollow shaft with shrink disk	HS20	HS30	HS35	HS40	HS50	9	H3A
SIMOLOC assembly system, metric	HF25	HF30	HF35	HF40	HF50	9	H3G
	HF20	HF25	HF30	HF35	HF40	9	H3H
SIMOLOC assembly system, imperial dimensions	HF1.0"	HF1.25"	HF1.375"	HF1.5"	HF2.0"	9	H3J
	HF0.75"	HF1.1875"	HF1.4375"	HF1.625"	HF1.9375"	9	H3K
	-	HF1.0"	HF1.25"	HF1.4375"	HF1.75"	9	H3L
	-	-	HF1.1875"	HF1.375"	HF1.625"	9	H3M
Worm gearboxes S							
Gearbox size	09	19	29				
Solid shaft	V16 x 40	V20 x 40	V20 x 40			1	
	V14 x 30	V18 x 40	V25 x 50			3	
Solid shaft, both ends	VD16 x 40	VD20 x 40	VD20 x 40			9	H5A
Hollow shaft	H16	H20	H20			5	
	H14	H18	H25			6	
Hollow shaft stainless steel	HX16	HX20	HX20			9	H8A
Plug-in shaft	VE16 x 40	VE20 x 40	VE20 x 40			7	

Hollow shaft with SIMOLOC assembly system

The new SIMOLOC assembly system has been designed to provide a friction-locked connection between the motor shaft made of drawn shaft material of grade h11 or lower and the hollow shaft in the gearbox.

The SIMOLOC assembly system offers a low-cost, easy-to-fit alternative to conventional shaft connections such as hollow

shaft with a feather key, hollow shaft with shrink disk or hollow shaft with spline.

It is compatible with the shaft-mounted designs of the parallel shaft, bevel and helical worm gearboxes.

Several diameters are available for each gearbox size.

Components of the SIMOLOC assembly system

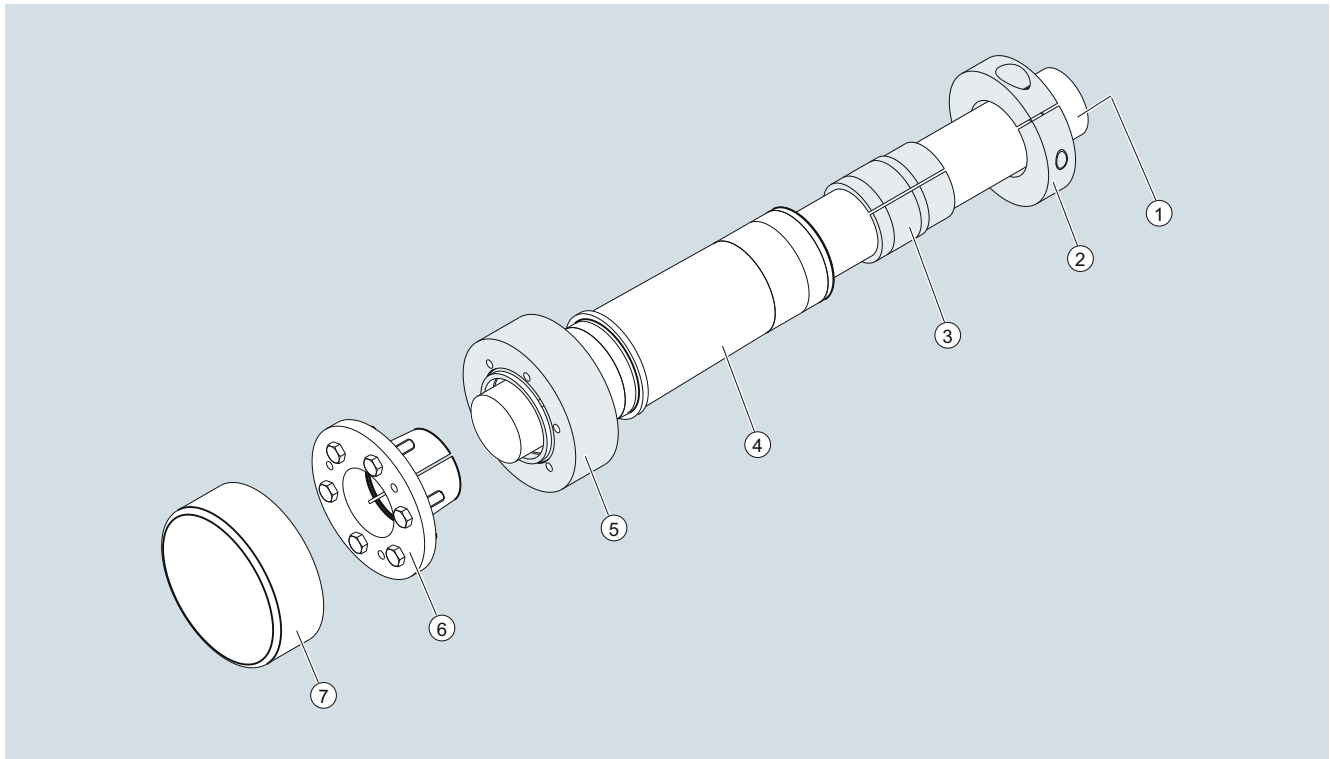

Fig. 9/11 SIMOLOC assembly system

- | | |
|---------------------------|-----------------------------|
| ① Machine shaft | ⑤ V-ring |
| ② Clamping ring | ⑥ Taper bushing |
| ③ Bronze bushing | ⑦ Rotating protection cover |
| ④ Hollow shaft of gearbox | |

Benefits

Cost reduction

- The drive shaft of the motor can be made of low-cost, drawn shaft material of grade h11 or lower.
- The shaft is cheaper to machine because there is no need to machine the shaft seat and a keyway is not required.

Quick and easy mounting

- Easy to mount and dismantle thanks to adequate clearance between the motor shaft and hollow shaft. The press fit is not made until the taper bushing is inserted.
- The press fit prevents the formation of fretting corrosion. The taper bushing can be removed easily in order to separate the press-fit connection.
- No tight fits need to be overcome when the gearbox is pushed onto the motor shaft.

Variability

- Quick adjustment of the gearbox to different motor shaft diameters is possible by replacement of the taper and bronze bushings.
- Dimensions can be converted easily between metric and inches.

Available diameters

The SIMOLOC assembly system can be supplied for shaft-mounted designs. 2 metric versions and 2 to 4 inch versions are available for all sizes.

Scope of supply

The gearbox is shipped with a SIMOLOC hollow shaft. The diameter-specific components are supplied as a separate assembly kit. The unit is supplied with preassembled rotating protection cover. The non-rotating protection cover can be ordered as an option.

Gearbox options

Mounting, output shaft bearings

Hollow shaft cover

Sealing caps

The bore of the hollow shaft is sealed using a plastic sealing cap.

Gearboxes in size 39 and larger with hollow shaft and shrink disk have a rotating protective cap.

The dimensions of the rotating protection cover can be seen in the dimensional drawings provided in the gearbox chapters.

For safety reasons, stationary protection covers may be required.

Protection cover

For sizes 39 to 189, a stationary protection cover for the hollow shaft and hollow shaft with shrink disk can be selected.

Size 29 has, as standard, a stationary protection cover for the design with shrink disk. For the design with hollow shaft, for size 29, a protection cover can also be selected.

The dimensions of the protection cover can be seen in the separate dimensional drawing provided in the gearbox chapters.

Order code:

Protection cover

G60

Radially reinforced output shaft bearings

The gearboxes can be supplied with the standard design or with a reinforced output shaft bearing design. The reinforced bearings allow higher radial and combined forces (radial and axial) to be absorbed.

Design	Possible for												Order code
Helical gearboxes Z and D													
Gearbox size	29	39	49	59	69	79	89	109	129	149	169	189	
Radially reinforced output shaft bearings					✓	✓	✓	✓	✓	✓			G20
Parallel shaft gearboxes F													
Gearbox size	29	39	49	69	79	89	109	129	149	169	189		
Radially reinforced output shaft bearings			✓*	✓	✓	✓	✓	✓	✓	✓	✓	✓	G20
Bevel gearboxes K													
Gearbox size	39	49	69	79	89	109	129	149	169	189			
Radially reinforced output shaft bearings		✓*	✓	✓	✓	✓	✓	✓	✓	✓	✓		G20

* Not possible for flange-mounted design with solid shaft (gearbox type FZF, FDF, KF)

Overview

Lubrication

The gearboxes are filled in the factory with a high quality lubricant. Lubricants permitted for the various gearbox types and applications are listed in the lubricant table.

Other oils from various lubricant manufacturers that have been approved by Siemens AG can be found on the Internet in the Service and Support pages in the List of approved and recommended gear lubricants T 7300:

<http://support.automation.siemens.com/WW/view/en/44231658>

Note:

For ambient conditions with a high air humidity and salt-laden air, we recommend that only mineral or PAO oils are used.

Oil quantities

The lubricant quantity depends on the gearbox type, size and mounting position. The corresponding oil quantities are specified in the operating instructions and on the rating plate of the geared motor.

Sealing

The standard models of gearbox are supplied with high-quality radial shaft sealing rings with dust protection lips. This sealing design is reliable for a wide range of applications.

Special application areas and environmental conditions require special radial shaft sealing rings and materials, which are coordinated with the particular gearbox oil and environment. This coordinated sealing system results in a high reliability and availability of the plant.

When compared to standard sealing systems, the maintenance intervals can be extended. This therefore reduces maintenance costs.

Sealing system

Output shaft sealing	Description	Ambient condition	Order code
Normal environmental stress			
Standard seal	High-quality NBR radial shaft sealing ring with dust protection lip.	Environment with low dust and pollution levels with low moisture.	-
Longer service life			
Seal with longer service life	The radial shaft sealing ring with protective lip is designed with an additional seal on the internal gearbox side. The sealing system has a high degree of reliability due to its resistance to impurities in the oil.	Environment with low dust and pollution levels with low moisture.	G23
Longer service life and increased environmental stress			
Seal for increased environmental stress	This seal is equipped with an additional fiber disk. In addition to the longer service life, it also provides increased protection against higher environmental stress as a result of dust and dirt deposits. As a consequence, the sealing system has a high degree of reliability. For additional environmental stress, e.g. water jets or significant levels of pollution as a result of production materials, please contact your local Siemens office.	Environments with increased pollution and dust levels as well as low moisture. Typical applications: Production areas with increased pollution and dust, such as wood chips, dusts or granulate as well as occasional spray water.	G24

Roller bearing greases for gearboxes and motors

The roller bearings of gearboxes and motors are lubricated in the factory with a roller bearing grease that is coordinated with the selected application area. The quantity of grease between the rolling elements and the space in front of the bearing depends on the operating conditions and the gearbox mounting position. For operation in the selected application areas, it is not necessary to lubricate the roller bearings.

We recommend that the grease filling of the roller bearings is also changed when the oil or shaft sealing rings are replaced.

Other greases supplied by different lubricant manufacturers that have been approved by Siemens AG are specified in the List of approved and recommended gearbox lubricants T 7300.

Gearbox options

Lubrication and sealing

Selection

The standard gearbox design can be used in the range from -20 up to +40° C. Additional oils for lower or higher ambient temperatures are available for selection.

Please inquire regarding geared motors outside the temperature range from -20 to +40 °C, as the suitability of the components used for the respective application must be checked.

Selection of lubricant				Selection of seal		
Area of application	Ambient temperature °C	Oil type Designation acc. to DIN 51502	Order code	Environmental stress		
				Normal	Normal	Increased
				Service life		
				Normal	Longer	Longer
				-	G23	G24
Helical gearboxes Z and D, parallel shaft gearboxes F and bevel gearboxes K						
Standard	-10 ... +40	CLP ISO VG220	K06	✓	✓	✓
	-30 ... +40	CLP ISO PAO VG220	K12	✓	✓	✓
	-40 ... +10	CLP ISO PAO VG68	K13	✓	✓	✓
	0 ... +80	CLP ISO PG VG460	K08	-	✓	✓
	-20 ... +50	CLP ISO PG VG220	K07	-	✓	✓
Foodstuff area	0 ... +40	CLP ISO H1 VG460	K11	-	✓	-
	-30 ... +10	CLP ISO H1 VG100	K14	-	✓	-
Biodegradable oil	-20 ... +40	CLP ISO E VG220	K10	✓	✓	-
Bevel gearboxes B						
Standard	-10 ... +40	CLP ISO PG VG220	K07	-	✓	✓ ¹⁾
	-30 ... +40	CLP ISO PAO VG220	K12	✓	✓	✓ ¹⁾
	-40 ... +10	CLP ISO PAO VG68	K13	✓	✓	✓ ¹⁾
	0 ... +80	CLP ISO PG VG460	K08	-	✓	✓ ¹⁾
Foodstuff area	0 ... +40	CLP ISO H1 VG460	K11	-	✓	-
	-30 ... +10	CLP ISO H1 VG100	K14	-	✓	-
Helical worm gearboxes C						
Standard	-10 ... +60	CLP ISO PG VG460	K08	-	✓	✓
	-30 ... +40	CLP ISO PAO VG220	K12	✓	✓	✓
	-40 ... +10	CLP ISO PAO VG68	K13	✓	✓	✓
Foodstuff area	0 ... +40	CLP ISO H1 VG460	K11	-	✓	-
	-30 ... +10	CLP ISO H1 VG100	K14	-	✓	-
Worm gearboxes S						
Standard	-10 ... +40	CLP ISO PG VG460	K08	✓	-	-
	-30 ... +20	CLP ISO PG VG220	K07	✓	-	-
Foodstuff area	0 ... +40	CLP ISO H1 VG460	K11	✓	-	-
	-30 ... +10	CLP ISO H1 VG100	K14	✓	-	-

¹⁾ Not possible with size B19

CLP = mineral oil

CLP PG = polyglycol oil

E = Ester oil, organic oil (bio oil / risk of water pollution, class WGK1)

PAO = Poly-alpha-olefin oil

CLP H1 = physically safe oil (USDA-H1 approval)

Overview

Gearboxes from size 39 for standard mounting positions are supplied as standard with pressure breather valve, oil level control and drain screw.

Gearbox size 29 is supplied ready for operation, lubricated for life and can be operated in mounting positions M1, M3, M5 and M6 without requiring a pressure breather valve. For mounting positions M2 and M4, they are equipped with a pressure breather valve.

Possible venting and oil level control options

Design	Possible for												Order code		
Helical gearboxes Z and D															
Size	29	39	49	59	69	79	89	109	129	149	169	189			
Lubricated for life	✓														
Pressure breather valve		✓	✓	✓	✓	✓	✓	✓	✓	✓	✓	✓	G45		
Oil expansion unit		✓	✓	✓	✓	✓	✓	✓	✓	✓	✓	✓	G47		
Oil sight glass			✓	✓	✓	✓	✓	✓	✓	✓	✓	✓	G34		
Magnetic oil drain screw		✓	✓	✓	✓	✓	✓	✓	✓	✓	✓	✓	G53		
Oil drain valve, straight		✓	✓	✓	✓	✓	✓	✓	✓	✓	✓	✓	G54		
Oil drain valve, angled		✓	✓	✓	✓	✓	✓	✓	✓	✓	✓	✓	G55		
Parallel shaft gearboxes F															
Size	29	39	49	69	79	89	109	129	149	169	189				
Lubricated for life	✓														
Pressure breather valve		✓	✓	✓	✓	✓	✓	✓	✓	✓	✓	✓	G45		
Oil expansion unit		✓	✓	✓	✓	✓	✓	✓	✓	✓	✓	✓	G47		
Oil sight glass			✓	✓	✓	✓	✓	✓	✓	✓	✓	✓	G34		
Magnetic oil drain screw		✓	✓	✓	✓	✓	✓	✓	✓	✓	✓	✓	G53		
Oil drain valve, straight		✓	✓	✓	✓	✓	✓	✓	✓	✓	✓	✓	G54		
Oil drain valve, angled		✓	✓	✓	✓	✓	✓	✓	✓	✓	✓	✓	G55		
Bevel gearboxes B															
Size	29					39					49				
Lubricated for life	✓														
Pressure breather valve						✓					✓	G45			
Oil expansion unit						✓					✓	G47			
Oil sight glass											✓	G34			
Magnetic oil drain screw											✓	G53			
Oil drain valve, straight											✓	G54			
Oil drain valve, angled											✓	G55			
Bevel gearboxes K															
Size	39	49	69	79	89	109	129	149							
Pressure breather valve	✓	✓	✓	✓	✓	✓	✓	✓					G45		
Oil expansion unit	✓	✓	✓	✓	✓	✓	✓	✓					G47		
Oil sight glass		✓	✓	✓	✓	✓	✓	✓					G34		
Magnetic oil drain screw	✓	✓	✓	✓	✓	✓	✓	✓					G53		
Oil drain valve, straight	✓	✓	✓	✓	✓	✓	✓	✓					G54		
Oil drain valve, angled	✓	✓	✓	✓	✓	✓	✓	✓					G55		
Helical worm gearboxes C															
Size	29				39			49			69			89	
Lubricated for life	✓ ¹⁾														
Pressure breather valve	✓				✓			✓			✓			G45	
Oil expansion unit					✓			✓			✓			G47	
Oil sight glass								✓			✓			G34	
Magnetic oil drain screw					✓			✓			✓			G53	
Oil drain valve, straight					✓			✓			✓			G54	
Oil drain valve, angled					✓			✓			✓			G55	
Worm gearboxes S															
Size	09					19					29				
Lubricated for life	✓					✓					✓				

¹⁾ Helical worm gearboxes for all mounting positions are equipped with a pressure breather valve.

Gearbox options

Venting and oil level control

Venting

Pressure breather valve

Gearboxes from size 39 are supplied with an installed pressure breather valve; this is suitable for both indoors and outdoors use.

Gearbox size 29 can be operated in mounting positions M1, M3, M5 and M6 without requiring a pressure breather valve. For mounting positions M2 and M4, they are equipped with a pressure breather valve.

Order code:

Pressure breather valve

G45

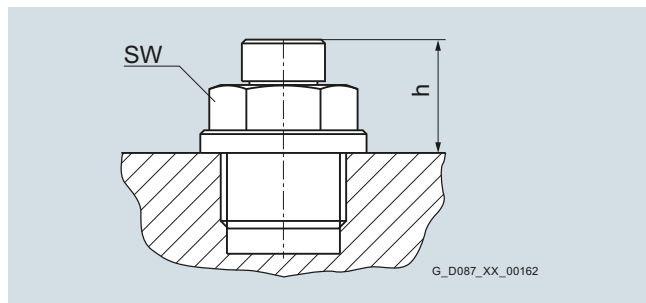

Fig. 9/12 Pressure breather valve

Technical specifications

Gearbox type	Size	Width across flats	Thread	Dimension h
		SW		
Helical gearboxes Z and D	29	12	G 1/8 A	15
	39	12	G 1/8 A	15
	49 ... 79	13	G 1/4 A	15
	89 ... 129	17	G 3/8 A	15
	149 ... 189	24	G 3/4 A	18
Parallel shaft gearboxes F	29	12	G 1/8 A	15
	39	12	G 1/8 A	15
	49 ... 79	13	G 1/4 A	15
	89 ... 129	17	G 3/8 A	15
	149 ... 189	24	G 3/4 A	18
Bevel gearboxes B	19, 29	12	G 1/8 A	15
	39	12	G 1/8 A	15
	49	13	G 1/4 A	15
Bevel gearboxes K	39	12	G 1/8 A	15
	49 ... 89	13	G 1/4 A	15
	109 ... 129	17	G 3/8 A	15
	149 ... 189	24	G 3/4 A	18
Helical worm gearboxes C	29	12	G 1/8 A	15
	39	12	G 1/8 A	15
	49 ... 89	13	G 1/4 A	15

Oil expansion unit

The oil expansion unit increases the expansion space for the lubricant. For certain types of construction and at high operating temperatures, this avoids that lubricant escapes.

The oil expansion unit is supplied as a mounting kit, and can be mounted onto the geared motor vertically or at an angle.

Order code:

Oil expansion unit

G47

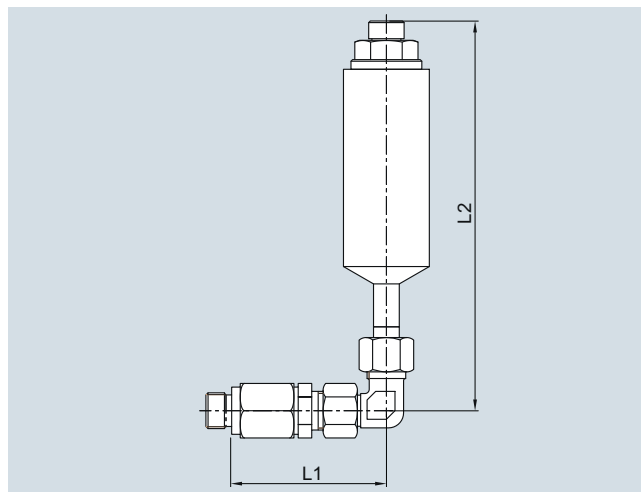

Fig. 9/13 Oil expansion unit type 1

Technical specifications

Gearbox type	Size	Motor size	Width across flats SW	Thread	Dimension L1 mm	Dimension L2 mm	
Helical gearboxes Z and D	39	63 ... 90		G1/8A	69.5	155	
		100 ... 112			82.5		
	49 ... 69	63 ... 90	19/22	G1/4A	42	155	
		100 ... 112			71.5		
		132			93.5		
	79	80 ... 90	19/22	G1/4A	42	155	
		100 ... 132			71.5		
		160			93.5		
	89	100 ... 132	22	G3/8A	42.5	155	
		160			71.5		
	Parallel shaft gearboxes F	39	63 ... 90	...	G1/8A	69.5	155
			100 ... 112			82.5	
49 ... 69		63 ... 90	19/22	G1/4A	42	155	
		100 ... 112			71.5		
		132			93.5		
79		80 ... 90	19/22	G1/4A	42.5	155	
		100 ... 132			71.5		
		160			93.5		
89		100 ... 132	22	G3/8A	42.5	155	
		160			71.5		
Bevel gearboxes B		49	63 ... 90	19/22	G1/4A	42	155
			100 ... 112			71.5	
	132		93.5				
Bevel gearboxes K	39	63 ... 90		G1/8A	69.5	155	
		100 ... 112			82.5		
	49	63 ... 90	19/22	G1/4A	42	155	
		100 ... 112			71.5		
	69	71 ... 90	19/22	G1/4A	42	155	
		100 ... 112			71.5		
	79	71 ... 90	19/22	G1/4A	42	155	
		100 ... 132			71.5		
		160			93.5		
	89	80 ... 132	19/22	G1/4A	71.5	155	
		160			93.5		
		180			93.5		
109	100 ... 132	22	G3/8A	42.5	155		
	160			71.5			
Helical worm gearboxes C	49 ... 69	63 ... 90	19/22	G1/4A	42	155	
		100 ... 112			71.5		
		132			93.5		
	89	80 ... 90	19/22	G1/4A	71.5	155	
		100 ... 132			71.5		
		132			93.5		

Gearbox options

Venting and oil level control

Venting

Oil expansion unit (continued)

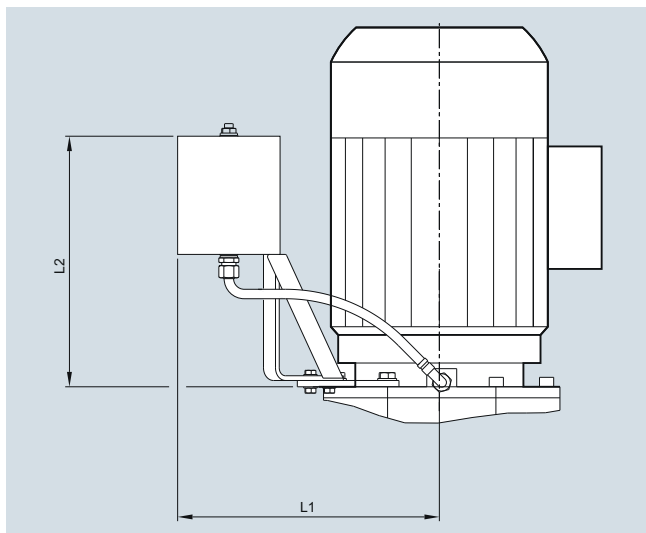

Fig. 9/14 Oil expansion unit type 2

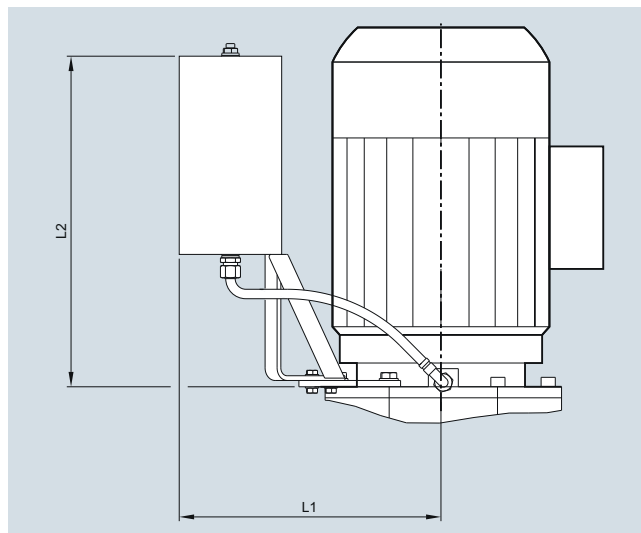

Fig. 9/15 Oil expansion unit type 3

Technical specifications

Gearbox type	Size	Motor size	Type	Thread	Dimension L1	Dimension L2
					mm	mm
Helical gearboxes Z and D	109	90 ... 225	2	G3/8A	406	334
	129	90 ... 250	2	G3/8A	442	334
	149	100 ... 250	3	G3/4A	465	505
	169	112 ... 250	3	G3/4A	493	505
	189	112 ... 250	3	G3/4A	493	505
Parallel shaft gearboxes F	109	90 ... 225	2	G3/8A	406	334
	129	90 ... 250	2	G3/8A	442	334
	149	100 ... 250	3	G3/4A	465	505
	169	112 ... 250	3	G3/4A	493	505
	189	112 ... 250	3	G3/4A	493	505
Bevel gearboxes K	129	90 ... 225	2	G3/8A	442	334
	149	90 ... 250	2	G3/4A (G3/8A)	465	334
	169	100 ... 250	3	G3/4A	493	505
	189	112 ... 250	3	G3/4A	493	505

Value in brackets for mounting position M4

Oil sight glass

For sizes 49 and higher, the oil level is checked using the oil level checking screw.

The oil sight glass is fitted with a reflector for visual monitoring.

Order code:

Oil sight glass

G34

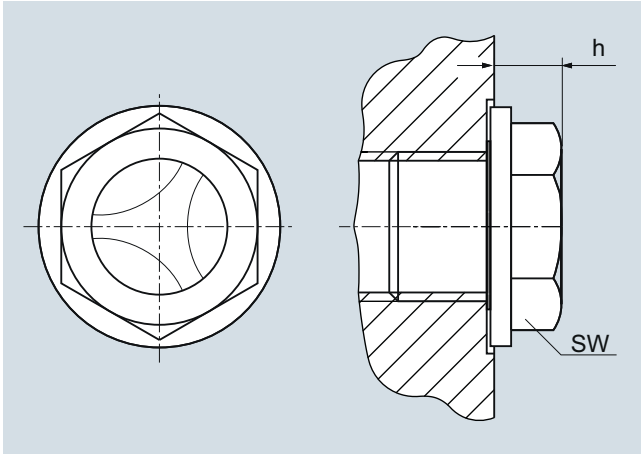

Fig. 9/16 Oil sight glass

Technical specifications

Gearbox type	Size	Width across flats	Thread	Dimension mm
		SW		
Helical gearboxes Z and D	49 ... 79	16	G 1/4 A	10
	89 ... 129	19	G 3/8 A	9
	149 ... 189	24	G 3/4 A	10
Parallel shaft gearboxes F	49 ... 79	16	G 1/4 A	10
	89 ... 129	19	G 3/8 A	9
	149 ... 189	24	G 3/4 A	10
Bevel gearboxes B	49	16	G 1/4 A	10
Bevel gearboxes K	49 ... 89	16	G 1/4 A	10
	109 ... 129	19	G 3/8 A	9
	149 ... 189	24	G 3/4 A	10
Helical worm gearboxes C	49 ... 89	16	G 1/4 A	10

Oil drain

Magnetic oil drain screw

For gearboxes from size 39, a magnetic screw plug is available that is inserted in the oil drain hole. This serves to collect any metal particles in the gearbox oil.

Order code:

Magnetic oil drain screw

G53

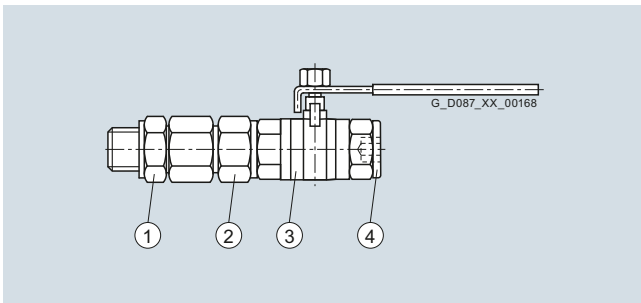

Fig. 9/17 Oil drain valve, straight

- ① Oil drain valve, straight
- ② Screw gland
- ③ Screw gland
- ④ Screw plug

Oil drain valve

For gearboxes from size 39, an oil drain valve is available in either a straight or angled design.

The oil drain valve is supplied complete with screw plug as kit.

Order code:

Oil drain valve, straight

G54

Oil drain valve, angled

G55

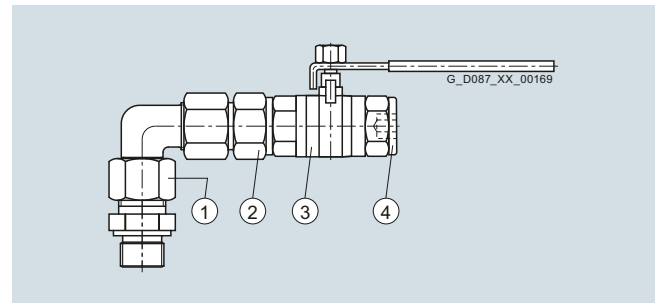

Fig. 9/18 Oil drain valve, angled

- ① Oil drain valve, angled
- ② Screw gland
- ③ Screw gland
- ④ Screw plug

Gearbox options

Reduced-backlash version

Reduced-backlash version

Gearboxes with low torsional backlash are required for high-precision positioning tasks. A minimal torsional backlash also has a favorable effect on torque spikes during startup and on load switching in the drive train.

The torsional backlash of a geared motor depends on several factors. The total torsional backlash is primarily influenced by circumferential backlash, bearing clearance and shaft-hub connections. In addition to the standard versions, reduced-backlash versions of SIMOGEAR geared motors are also available. Thanks to the overall concept and the plug-on pinion system, motors with lower torsional backlash values can be supplied.

To ensure that the entire driven machine can be designed with minimum possible backlash, it is advisable to select the solution with integral motor mounting (without adapter), output shafts with shrink disk connection or with smooth shafts (without feather key). In this case, only backlash-free power transmission elements should be used.

The specified torsional backlash in minutes of the angle ['] is based on the maximum rotation angle of the output shaft (no load, max. 1 % of rated output torque) with stationary input shaft.

For the exact values, refer to the torque tables. If no values are specified in the tables, this means that a reduced-backlash version is not available for the specific version.

The dimensions of the reduced-backlash gearboxes are identical to those of the standard versions.

Order code:

Reduced-backlash version

G99

Reduced-backlash versions of the following gearboxes are available

Gearbox	Size									
	09	19	29	39	49	59	69	79	89	
Helical gearboxes Z and D	-	-	✓	✓	✓	✓	✓	✓	✓	
Parallel shaft gearboxes F	-	-	✓	✓	✓	-	✓	✓	✓	
Bevel gearboxes B	-	-	✓	✓	✓	-	-	-	-	
Bevel gearboxes K	-	-	✓	✓	✓	-	✓	✓	✓	
Helical worm gearboxes C	-	-	-	-	-	-	-	-	-	
Worm gearboxes S	-	-	-	-	-	-	-	-	-	

Adapter options

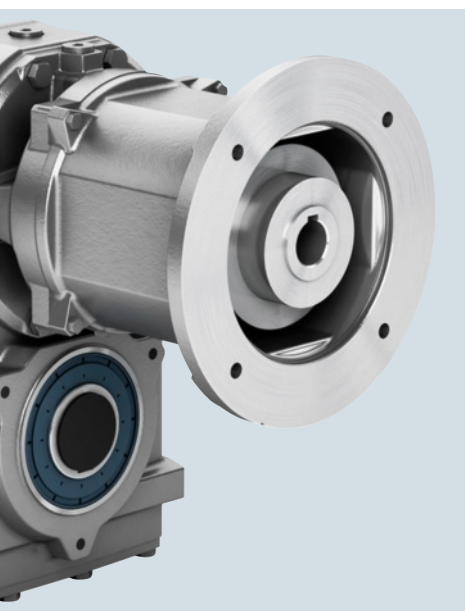

10/2 **Mounted components**

- Power transmission
- 10/2 Backstop
- 10/3 Slip clutch with proximity switch
- 10/3 Design for motor shaft without feather key

10/4 **Designs for special environmental conditions**

- 10/4 Condensation drain hole

Adapter options

Mounted components

Power transmission

Backstop

For applications that only require one permissible direction of rotation, adapters K2 and K3 can be supplied with a backstop. In this case, an **X** is added to the adapter code (K2X, K3X).

The advantage of integrating the backstop into the adapter rather than into the motor is that the motor can be dismantled even under full-load conditions.

The backstop is incorporated into the adapter and does not alter the overall dimensions of the unit.

Order code:

Backstop (X)

A15

Design and mode of operation

The backstops have centrifugal sprags and are suitable for use up to a maximum speed of 4 500 rpm.

The backstops have been designed to offer a long service life, provided that they are used at a higher speed than the minimum specified in the table. Once this speed is reached and exceeded, the sprags lift off so that the backstop is not subject to wear and is maintenance-free.

Note:

It is necessary to specify the desired direction of rotation of the output shaft when ordering a gearbox with backstop. The direction of rotation is determined by front view of the output shaft.

See also "Direction of rotation", page 1/20.

With bevel and helical worm gearboxes, it is again necessary to specify the side on which the output shaft is located, i.e. either "Output side A" or "Output side B". The output side is defined by specifying the mounting position.

See also "Mounting position", page 9/2.

Minimum disengage speed of the backstop

Adapter K2											
IEC size		80	90	100	112	132	160	180	200	225	250
Disengage speed	rpm	820	820	750	750	670	670	670	610	610	610
Maximum torque of the backstop	Nm	12.3	25	49	66	151	247	362	494	741	906
Adapter K3											
NEMA size		56	140	180	210	250	280	320	360		
Disengage speed	rpm	820	820	750	670	670	670	610	610		
Maximum torque of the backstop	Nm	12.3	25	49	151	247	362	741	906		

Slip clutch with proximity switch

Gearboxes with adapter K2 or K3 can be fitted with a slip clutch as an option.

The slip clutch creates a friction-locked connection between the motor output shaft and the gearbox input shaft until a set torque value is achieved. Once this torque is exceeded the clutch will slip.

Slip clutches are used when there is a risk of the geared motor sustaining damage as a result of stalling.

A slip torque setting for the slip clutch can be specified in plain text.

The slip torque should equal approximately 1.4 to 1.6 times the input torque. The slip torque scatter band ($\pm 20\%$) should be taken into account in the specified slip torque value.

Speed monitoring

In order to prevent uncontrolled slippage of the slip clutch, we recommend the implementation of a speed monitoring system.

Adapters K2 and K3 with slip clutch are equipped with a proximity switch for this purpose.

The proximity switch operates contact-free according to the sampling method and emits one signal per coupling rotation which is evaluated by a speed monitor (not included in the scope of supply).

The signal sequence sent by the proximity switch is compared in the speed monitor with the set setpoint speed. If the speed is below or above the configured setpoint speed, a relay is actuated (depending on the function setting) via an output stage.

The speed monitor and the output stage are not included in the scope of supply.

Order code:

Slip clutch with proximity switch

A17

Slip torque setting

Y00

Plain text:

Y00*RKD@...*

Example: Required slip torque 125 Nm

Plain text specification: Y00*RKD@125*

Slip torque setting

Adapter size	Settable slip torque	
	min.	max.
Adapter K2		
80	1.4	9.3
90	3.6	18.2
100	8.5	48
112	8.5	48
132	19	95
160	40	180
180	100	260
200	125	360
225	180	530
250	225	650
Adapter K3		
56	0.5	4.6
140	3.6	18.2
180	8.5	48
210	19	95
250	40	180
280	100	260
320	180	530
360	225	650

Design for motor shaft without feather key

The standard model of the adapter KQ is designed for the mounting of servo motors which have a shaft with feather key.

A version for motor shafts without feather key can be selected as an alternative.

In this case, an **S** is added to the adapter code (KQS).

Order code:

Motor shaft without feather key (S)

A08

Adapter options

Designs for special environmental conditions

Condensation drain hole

The adapters K2 and K3 can be supplied with a condensation drain hole for gearboxes in mounting position M4. The condensation drain hole drains condensation (which can form in extreme ambient temperatures) out of the gearbox.

Order code:

Condensation drain hole

A26

General options



11/2	Designs for special environmental conditions
11/2	Extreme ambient temperatures
11/3	Surface treatment and preservation
11/3	Surface treatment
11/3	• Surface pretreatment
11/4	• Painting flange surfaces
11/4	• Colors
11/5	Preservation
11/5	• Long-term preservation up to 36 months
11/6	Rating plate
11/6	Overview
11/6	Second rating plate, supplied loose
11/6	Documentation
11/6	Operating instructions
11/6	Test certificates

General options

Designs for special environmental conditions

Extreme ambient temperatures

The ambient temperature range for products listed in the catalog extends from -10 to +40 °C. In addition, when using the recommended oils, drives can be selected for the range extending from -20 to +40 °C.

When appropriately modified, SIMOGEAR gearboxes can be operated at temperatures extending from -40 to -20 °C. After specifying the temperature range, the operating and starting mode as well as the load, we will gladly offer this design.

Technical changes especially involve the electrical components as well as the selection of lubricants and seals.

At higher ambient temperatures above +40 °C, the permissible oil sump temperature must not be exceeded. Please contact Siemens if you would like your drive to be thermally checked.

In addition, at higher temperatures, a special motor design is required, which we will be glad to offer.

Surface treatment

We offer five high-quality paint systems in various colors to protect drives against corrosion and external environmental effects.

Our corrosion protection system is designed in accordance with the corrosivity categories of EN ISO 12944-2.

Gearboxes, size 49 and higher, are painted in RAL 7016 (anthracite gray) to corrosivity category C1 as standard. This ensures that they are protected against corrosion for indoors use.

Gearboxes, sizes 29 and 39 with an aluminum housing are supplied unpainted as standard.

All of the unpainted parts of the products are treated with corrosion protection for 6 months.

Surface pretreatment

For especially demanding applications, the drives can also be pretreated in order to achieve a uniform paint coat thickness also at hidden locations or those difficult to access.

Order code:

Special pretreatment

L19

Corrosivity category	Paint system			Description	Order code
	Primer	Intermediate coat	Top coat		
Surface protection					
<i>Aluminum gearbox housing ¹⁾</i>					
C1/unpainted (standard)	-	-	-	<ul style="list-style-type: none"> Indoor installation Heated buildings with neutral atmospheres 	L00
C1 Normal environmental stress	-	-	1-component hydro paint	<ul style="list-style-type: none"> Resistant to greases, conditionally resistant to mineral oils, aliphatic solvents Standard paint 	L02
<i>Cast iron gearbox housing ²⁾</i>					
C1 Normal environmental stress	-	-	1-component hydro paint	<ul style="list-style-type: none"> Indoor installation Heated buildings with neutral atmospheres Resistant to greases, conditionally resistant to mineral oils, aliphatic solvents Standard paint 	L02
<i>All geared motors</i>					
C2 Low environmental stress	2-component polyurethane	-	2-component polyurethane	<ul style="list-style-type: none"> Indoor and outdoor installation Unheated buildings with condensation, production areas with low humidity, e.g. warehouses and sports facilities Atmospheres with little pollution, rural areas Resistant to greases, mineral oils and sulfuric acid (10 %), caustic soda (10 %) and conditionally resistant to aliphatic solvents 	L03
C3 Average environmental stress	2-component polyurethane	-	2-component polyurethane	<ul style="list-style-type: none"> Indoor and outdoor installation Production areas with high humidity and some air pollution, e.g. food production areas, dairies, laundries and breweries Urban and industrial atmospheres, moderate contamination from sulfur dioxide, coastal areas with low salt levels Resistant to greases, mineral oils, aliphatic solvents, sulfuric acid (10 %), caustic soda (10 %) 	L04
C4 High environmental stress	2-component epoxy zinc phosphate	-	2-component polyurethane	<ul style="list-style-type: none"> Indoor and outdoor installation Chemical plants, swimming pools, wastewater treatment plants, electroplating shops, and boathouses above seawater Industrial areas and coastal areas with moderate salt levels Resistant to greases, mineral oils, aliphatic solvents, sulfuric acid (10 %), caustic soda (10 %) 	L20
C5 Very high environmental stress	2-component epoxy zinc phosphate	2-component epoxy iron mica	2-component polyurethane	<ul style="list-style-type: none"> Indoor and outdoor installation Buildings/areas with almost constant condensation and high degrees of pollution, e.g. malt factories and aseptic areas Industrial areas with high humidity and aggressive atmosphere, coastal areas and offshore environments with high salt levels Resistant to greases, mineral oils, aliphatic solvents, sulfuric acid (10 %), caustic soda (20 %) 	L05

¹⁾ Helical gearboxes D/Z19 to D/Z39, parallel shaft gearboxes F29 and bevel gearboxes B29 and B39

²⁾ The bevel gearbox B49 is supplied painted

General options

Surface treatment and preservation

Surface treatment (continued)

Corrosivity category	Paint system			Description	Order code
	Primer	Intermediate coat	Top coat		
Primer				Ability to be painted	
C3 G	2-component polyurethane	-	-	• 2-component polyurethane paint, 2-component epoxy paint and acid-hardening paint, 2-component acrylic paint	L01
C4 G	2-component epoxy zinc phosphate	-	-	• 2-component polyurethane paint, 2-component epoxy paint and acid-hardening paint, 2-component acrylic paint	L09
Unpainted	-	-	-	• Plastic paint, synthetic resin paint, oil paint, 2-component polyurethane paint, 2-component epoxy paint	L00





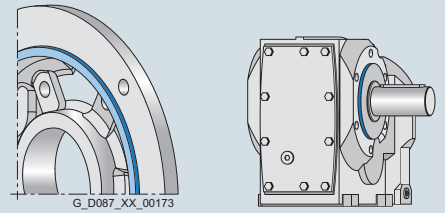
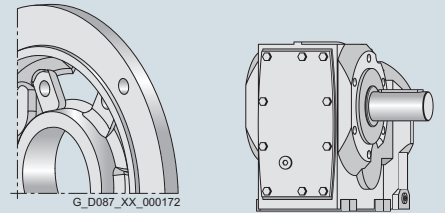
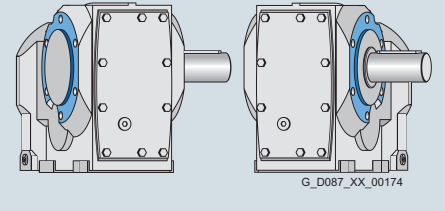

Painting flange surfaces

For flange-mounted designs, the flange surface and centering are not painted. The versions listed in the table can be optionally selected.

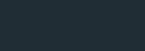
Design	Figure	Possible for	Order code
Centering not painted	 <p>G_D087_XX_00173</p>	<ul style="list-style-type: none"> • Flange-mounted design • Housing flange design 	L11
Flange completely painted	 <p>G_D087_XX_000172</p>	<ul style="list-style-type: none"> • Flange-mounted design • Housing flange design 	L12
Centering flange not painted on both sides	 <p>G_D087_XX_00174</p>	<ul style="list-style-type: none"> • Housing flange design for bevel gearbox and helical worm gearbox 	L27

Colors

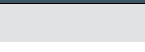
In addition to anthracite gray (RAL 7016), you can select from other standard colors.

RAL color	Designation	Color, example	Order code
RAL 7016	Anthracite gray (standard)		L75
RAL 5015	Sky blue		L50
RAL 7011	Iron gray		L51
RAL 7030	Stone gray		L55
RAL 7031	Blue gray		L53
RAL 7035	Light gray		L54

You can find additional colors in our [SIMOGEAR Configurator](#) electronic catalog.

Note

For light colors in corrosivity category C1 we recommend selection of surface treatment in the corrosivity category one level higher to ensure adequate and uniform coloring for the geared motor.

Preservation

All gearboxes and geared motors are preserved as standard for 6 months.

Long-term preservation up to 36 months

If the gearboxes are stored for longer than 6 months, then we recommend the "Long-term preservation" option. A VCI corrosion inhibitor (volatile corrosion inhibitor) is added to the gearbox oil.

Until commissioning, it is not permissible that the gearbox is opened, as otherwise the VCI corrosion inhibitor will vaporize. The oil level must be checked before commissioning. Corrosion protection is also applied to the flange contact surfaces and shaft extensions. We recommend that the gearbox is stored in the appropriate mounting position.

Storage conditions

Geared motors, stored in dry, dust free and evenly tempered rooms do not require any special packaging.

In all other areas, the units must be packaged in foil with desiccant and moisture indicator. If required, protection must be provided against mold and termites. The storage location must be vibration- and shock-free. The storage conditions must be regularly checked.

Order code:

Long-term preservation up to 36 months

K17

[For information about storage and commissioning please refer to the operating instructions.](#)

General options

Rating plate, documentation

Rating plate

Overview

The rating plates on the gearboxes and geared motors are normally manufactured out of coated aluminum foil. They are covered with a special masking film which ensures permanent resistance to UV radiation and media of all kinds (oils, greases, salt water, cleaning agents, etc.).

The adhesive and the material ensure firm adhesion and long-term legibility within the operating temperature range from -40 °C to +155 °C.

A rating plate is attached to the gear end of gearboxes with an adapter. The attached motors have a separate rating plate.

General data on the rating plate

- 1 Matrix code
- 2 Applicable standard
- 3 **Serial No.**
- 4 CE marking or other marking, if required
- 5 Article No.
- 6 Model - Type - Size
- 7 Mounting positions (IM)
- 8 Weight m [kg]
- 9 Customer ID
- 10 Oil quantity [l] main gearbox/intermediate gearbox
- 11 Oil type
- 12 Oil viscosity ISO VG class to DIN 51519 / ISO 3448
- 13 Total transmission ratio
- 14 Rated frequency f [Hz]
- 15 Gearbox output speed n_2 [rpm]

When ordering a replacement/spare part, always specify the serial No.

Second rating plate, supplied loose

An additional rating plate can be supplied loose for all gearboxes.

Order code:

Second rating plate, supplied loose

K41

Documentation

Operating instructions

The gearboxes are shipped with a set of operating instructions in German/English and a Manual Collection on CD for each delivery batch.

The operating instructions include the following documents:

- Replacement part drawings and lists
- Declaration of incorporation of partly completed machinery according to the EC Machinery Directive 2006/42/EC (gearboxes)
- EC Declaration of Conformity according to Directive 2006/95/EC (motors)

The Manual Collection contains all of the operating instructions in Czech, Dutch, English, French, German, Italian, Russian, Spanish, and Swedish.

Documentation provided with the product	Language	Order code
1 set of operating instructions and 1 Manual Collection (CD) for each geared motor	German	W21
	English	W22

Test certificates

On request, the following documents are available by e-mail:

Additional documentation	The following is checked:	Order code
Declaration of compliance with the order EN 10204-2.1 and factory test report EN 10204-2.2, geared motor	-	On request
Factory test report EN 10204-2.2 for material	-	On request
Acceptance test certificate EN 10204-3.1 for gearboxes	<ul style="list-style-type: none"> • Output shaft bearings • Concentricity of the output shaft • Noise (subjective evaluation) 	W11
Acceptance test certificate EN 10204-3.1 for paint finish	-	W12

Appendix



12/2	Lists
12/2	List of order codes
12/4	List of variables to dimension the drive
12/7	Subject index
12/10	List of abbreviations
12/11	Training
12/11	Training for Industry
12/11	You benefit from practical training right from the manufacturer
12/11	Important key data
12/11	Contact
12/12	Partner at Siemens
12/13	Online Services
	<u>Information and Ordering Options on the Internet and DVD</u>
12/13	The Future of Manufacturing in the WWW
12/13	Product Selection Using the Interactive CA 01 Automation and Drives Catalog
12/13	Easy Shopping with the Industry Mall <u>Information and Download Center, Social Media, Mobile Media</u>
12/14	Downloading Catalogs
12/14	Social and Mobile Media
12/15	Industry Services
12/15	<u>Your machines and plant can do more – with Industry Services.</u>
12/16	<u>Industry Services for the entire life cycle</u>
12/16	Online Support
12/16	Technical Support
12/17	Spare Parts
12/17	Repair Services
12/17	Field Services
12/18	Training
12/18	Technical Consulting & Engineering Support
12/18	Energy & Environmental Services
12/19	Modernization & Optimization Services
12/19	Plant Maintenance & Condition Monitoring
12/19	Service Contracts
12/22	Conditions of sale and delivery

Appendix

Lists

List of order codes

Order code	Special design Designation	Detailed data Chapter/Page
Adapter power transmission		
A08	Motor shaft without feather key/coupling for motor without feather key	10/3
A15	Adapter backstop	10/2
A17	Slip clutch with proximity switch	10/3
Designs for special environmental conditions		
A26	Condensation drain hole	10/4
Mounting positions		
D01 ... D06	Mounting positions of the geared motors (helical and parallel shaft gearboxes)	9/2, 9/4 ... 9/16
D11 ... D16 D21 ... D26	Mounting position of the geared motors (bevel, helical worm and worm gearboxes)	9/2, 9/17 ... 9/32
Special mounting positions		
E01 ... E17	Y axis of rotation	9/33
E21 ... E37	X axis of rotation	9/33
E41 ... E57	Z axis of rotation	9/33
Shaft-mounted version helical worm gearbox		
G09	Radially reinforced output shaft bearings	9/38
G10	Radially reinforced output shaft bearings	9/38
Output shaft bearings		
G20	Radially reinforced output shaft bearings	9/42
Output sealing		
G23	Seal with longer service life	9/43
G24	Seal for increased environmental stress	9/43
Oil level control		
G34	Oil sight glass	9/49
Gearbox venting		
G45	Pressure breather valve	9/46
G47	Oil expansion unit	9/47
Oil drain		
G53	Magnetic oil drain screw	9/49
G54	Oil drain valve, straight	9/49
G55	Oil drain valve, angled	9/49
Hollow shaft cover		
G60	Protection cover	9/42
Water drain holes		
G77	Water drain holes at the output flange	9/36
Reduced-backlash version		
G99	Reduced-backlash version	9/50
Flange diameter		
H02 ... H11	Flange diameter	9/35
Lubricants		
K06	CLP ISO VG220	9/43
K07	CLP ISO PG VG220	9/43
K08	CLP ISO PG VG460	9/43
K10	CLP ISO E VG220	9/43
K11	CLP ISO H1 VG460	9/43
K12	CLP ISO PAO VG220	9/43
K13	CLP ISO PAO VG68	9/43
K14	CLP ISO H1 VG100	9/43
Long-term preservation		
K17	Long-term preservation up to 36 months	11/5

Order code	Special design Designation	Detailed data Chapter/Page
Direction of rotation of the output shaft (required with backstop)		
K18	Clockwise	1/20
K19	Counterclockwise	1/20
Rating plate and additional plates		
K41	Second rating plate, supplied loose	11/6
ATEX explosion protection designation		
K70	Ex II 2 G/D IIC ck T4/120 °C	1/19
K80	Ex II 2 G/D IIB ck T4/120 °C	1/19
K81	Ex II 3 G/D IIB ck T4/120 °C	1/19
K82	Ex II 3 G/D IIC ck T4/120 °C	1/19
Surface treatment		
L00	Unpainted	11/3
L01	Primed according to corrosivity category C3 G	11/4
L02	Surface protection for normal environmental stress C1	11/3
L03	Surface protection for low environmental stress C2	11/3
L04	Surface protection for average environmental stress C3	11/3
L05	Surface protection for very high environmental stress C5	11/3
L09	Primed according to corrosivity category C4 G	11/3
L11	Centering not painted	11/4
L12	Flange completely painted	11/4
L19	Special pretreatment	11/3
L20	Surface protection for high environmental stress C4	11/3
L27	Centerings not painted on both sides	11/4
RAL colors		
L50	RAL 5015 sky blue	11/4
L51	RAL 7011 steel gray	11/4
L53	RAL 7031 blue gray	11/4
L54	RAL 7035 light gray	11/4
L55	RAL 7030 stone gray	11/4
L75	RAL 7016 anthracite gray	11/4
	Other colors on request	11/4
Speed monitoring		
Y00	Slip torque setting	10/3
Documentation		
W11	Acceptance test certificate EN 10204-3.1 for gearboxes	11/7
W12	Acceptance test certificate EN 10204-3.1 for paint finish	11/7
W21	1 set of operating instructions and 1 Manual Collection (CD) in German	11/7
W22	1 set of operating instructions and 1 Manual Collection (CD) in English	11/7

Appendix

Lists

List of variables to dimension the drive

Overview of data to dimension drives

Code	Description	Unit
a	Gearbox constants for calculating the radial force	kNmm
α	Force application angle	°
b, d, l, y, z	Gearbox constants	mm
C	Additional factor to calculate the radial force	-
d	Diameter of the input element	mm
d_0	Average diameter of the mounted transmission element	mm
η	Efficiency	%
f_B	Service factor	-
f_{B1}	Required service factor	-
f_{Btot}	Service factor of the driving machine	-
F_{ax}	Permissible axial force	N
F_M	Maximum permissible operating force from mounted motor	N
F_{Mred}	Reduced maximum permissible operating force from mounted motor	N
F_{mot}	Motor weight force	N
F_{R2}	Permissible radial force at the center of shaft extension (l/2)	N
F_{Ravail}	Available radial force from the mounted transmission element	N
F_x	Permissible radial force from out of center force application point	N
F_{xperm1}	Permissible radial force, limited by the bearing service life, at a distance of x from the shaft shoulder	N
F_{xperm2}	Permissible radial force, limited by the shaft strength, at a distance of x from the shaft shoulder	N
i	Transmission ratio	-
J_2	Moment of inertia of the load referred to the output speed of the gearbox	kgm ²
J_{AD}	Moment of inertia of the adapter referred to the input speed	kgm ²
J_B	Moment of inertia of the brake	kgm ²
J_G	Moment of inertia of the gearbox referred to the input speed	kgm ²
J_{mot}	Moment of inertia of the motor	kgm ²
J_x	Moment of inertia of the load referred to the input speed	kgm ²
J_z	Additional moment of inertia of a high inertia fan	kgm ²
J_{Bstp}	Moment of inertia of cage and inner ring	kgm ²

Code	Description	Unit
k_1	Motor length	mm
$k_{1/2}$	Half motor length	mm
L_{h10}	Nominal bearing service life	h
L_{na}	Modified bearing service life	h
L_{pfA}	Measuring surface sound pressure level	dB (A)
L_{WA}	Sound power level	dB (A)
m	Drive weight without any oil	kg
m_{AF}	Mass acceleration factor	-
$M_b exist$	Existing bending torque	Nm
$M_b perm$	Permissible bending torque	Nm
n_1	Input speed of the gearbox	rpm
n_2	Output speed of the gearbox	rpm
n_{dis}	Disengage speed	rpm
n_{max}	Maximum speed	rpm
n_{rated}	Rated speed	rpm
P_{req}	Required input power	kW
P_{mot}	Motor power	kW
r	Radius of the output element	m
F_{ex}	Exact number of teeth ratio	-
T_{1perm}	Permissible input torque of the adapter	Nm
T_{1max}	Short-time maximum permissible input torque of the adapter	Nm
T_{1mot}	Continuous torque of the motor	Nm
T_2	Required input torque of the driven machine	Nm
T_{2N}	Maximum output torque of the gearbox	Nm
x	Distance from the shaft shoulder up to the point where force is applied	mm
X	Distance from center of gravity	mm
z_5	Length of the adapter	mm
ϑ_{amb}	Ambient temperature	°C

Important drive technology variables

SI unit Size	Symbol		Unit symbol		Designation or conversion factor*
	SI	Previously	SI	Previously	
Length (distance)	l	L, s	m	m	1 km = 1 000 m
Area	A	F	m ²	m ²	1 m ² = 100 dm ²
Volume	V	V	m ³	m ³	1 m ³ = 1 000 dm ³ 1 dm ³ = 1 l
Plane angle	α, β, γ	α, β, γ	rad	Degrees °	1 rad = 1 m/m 1 L = $\pi/2$ rad 1° = $\pi/180$ rad
Rotation angle	ϕ	φ		Degrees °	1' = 1°/60; 1'' = 1'/60
Time					1 min = 60 s 1 h = 60 min
Time period/duration	t	t	s	s	1 d = 24 h
Frequency	f	f	Hz	1/s	1 Hz = 1/s
Speed	n	n	rpm	rpm	Rotations per minute
Velocity	v	v	m/s	m/s	1 km/h = $\frac{1}{3.6}$ m/s
Acceleration	a	b	m/s ²	m/s ²	g = 9.81 m/s ²
Acceleration due to gravity	g	g			
Angular velocity	ω	Ω	rad/s	1/s	
Angular acceleration	α	ζ	rad/s ²	1/s ²	
Mass	m	m	kg	kg	1
Density		d	kg/dm ³	kg/dm ³	10 ³
Force	F	P, K	N	kp	9.81
Force due to weight	G	G			1 N = 1 kg · 1 m/s ²
Pressure	p	p	Pa N/m ²	kp/cm ²	1 Pa = 1 N/m ² 9.81 · 10 ⁴
Mechanical tension	σ	σ	N/mm ²	kp/mm ²	9.81
Work	W	A		kpm	9.81
Energy	W	E	J	kcal	4187
Quantity of heat	Q	Q			1 J = 1 Nm = 1 Ws
Torque of a force		M _t			9.81
Torque	T	M _d	Nm	kpm	1 Nm = 1 J
Bending torque		M _b			
Power	P	N	W	PS	735.5 1 W = 1 J/s = 1 Nm/s = $\frac{\text{kgm}^2}{\text{s}^3}$
Mass moment of inertia	J	θ	kgm ²	kpm ²	9.81

Conversion from kW to hp:

$$1 \text{ kW} = 1.34102 \text{ hp}$$

$$1 \text{ hp} = 0.745700 \text{ kW}$$

$$1 \text{ hp} = 1.01387 \text{ PS}$$

hp = horse power (US)

PS = Pferdestärke (horsepower in German)

* The numerical value of a variable in previously used units multiplied by the conversion rate gives the numerical value of the variable in SI units.

Appendix

Lists

List of variables to dimension the drive

Important drive technology variables (continued)

SI unit Size	Symbol		Unit symbol		Designation or conversion factor ^{*)}
	SI	Previously	SI	Previously	
Dynamic viscosity	η	η	Pa · s	P	10^{-1}
Kinematic viscosity	ν	ν	m ² /s	St	10^{-4}
Electrical current	I	I	A	A	1 A = 1 W/V = 1 V/Ω
Electrical voltage	U	U	V	V	1 V = 1 W/A
Electrical resistance	R	R	Ω	Ω	1 Ω = 1 V/A = 1/S
Electrical conductance	G	G	S	S	1 S = 1/Ω
Electrical capacitance	C	C	F	F	1 F = 1 C/V
Electric charge	Q	Q	C	C	1 C = 1 A · s
Inductance	L	L	H	H	1 H = 1 Vs/A
Magnetic flux density Induction	B	B	T	G	10^4 1 T = 1 Wb/m ²
Magnetic field strength	H	H	A/m	A/m	
Magnetic flux	ϕ	ϕ	Wb	M	10^8 1 Wb = 1 V · s
Temperature	T(θ)	t	K(°C)	°C	0 K = -273.15 °C

* The numerical value of a variable in previously used units multiplied by the conversion rate gives the numerical value of the variable in SI units.

	Chapter/Page		Chapter/Page
A			
Acceptance test certificate	11/7		
Adapter	1/4, 8/1		
Adapter options	10/1		
Adapters for mounting a NEMA motor	8/3		
Adapters for mounting a servo motor	8/3		
Adapters for mounting an IEC motor	8/2		
Additional documentation	11/7		
Additional factor C	2/9		
Ambient temperatures, extreme	11/2		
Appendix	12/1		
Article No. code	1/8		
Available radial force	2/9		
Axial force, permissible	2/9		
B			
Backstop	10/2		
Bearing service life	2/9		
Bearing, reinforced	9/42		
Benefits	1/5		
Bevel gearbox, modular system	1/13		
Bevel gearboxes	5/1		
Biodegradable oil	9/44		
C			
Checklist	2/3		
Colors	11/4		
Condensation drain hole	10/4		
Configuring a gearbox	2/4		
Configuring sequence	2/2		
Configuring the adapter	2/10		
Corrosivity category	11/3		
Coupling adapter K2, K3, K8 and KQ	8/2		
D			
Declaration of compliance	11/7		
Designs for special environmental conditions	11/2		
Determining the drive data	2/2		
Determining the load classification	2/5		
Determining the required service factor	2/5		
Dimensional drawings	3/27, 4/25, 5/16, 6/18, 7/6		
Dimensional drawings, notes on	1/18		
Direction of rotation	1/20		
Documentation	11/7		
E			
Efficiency optimization	2/4		
Environmental conditions	11/2		
Extreme ambient temperatures	11/2		
F			
Factory test report	11/7		
Flange diameter	9/35		
Flange surfaces, painting	11/4		
Flange-mounted designs	9/35		
Foot-mounted design	9/4, 9/15, 9/17, 9/23		
Foot/flange-mounted design	9/6		
G			
Gearbox constants	2/10		
Gearbox efficiency	2/4		
Gearbox lubricating oils	9/43		
Gearbox options	9/1		
Gearbox types	1/2		
Gearbox, type designation	1/10		
Gearboxes	1/2		
Geared motors for use worldwide	1/19		
General technical specifications	1/19, 8/4		
Guidelines for selection and ordering	1/8		

Appendix

Lists

Subject index

	Chapter/Page		Chapter/Page
H		O	
Helical gearboxes	3/1	Oil drain	9/49
Helical worm gearboxes	6/1	Oil drain screw	9/49
Hollow shaft	9/39	Oil expansion unit	9/47
Hollow shaft cover	9/42	Oil sight glass	9/49
Hollow shaft with shrink disk	9/39	Operating instructions	11/7
Hollow shaft with SIMOLOC	9/39	Options, general	11/1
Hollow shaft, inches	9/39	Ordering data	1/8
Housing flange	9/8, 9/13, 9/19, 9/24	Ordering example	1/9
Input speed	2/7		
L		P	
Load classification of driven machines	2/5	Paint system	11/3
Load classification, determining	2/5	Painting flange surfaces	11/4
Long-term preservation up to 36 months	11/5	Parallel shaft gearboxes	4/1
Lubrication	9/43	Permissible axial forces	2/9
		Permissible radial force	2/9
		Power transmission	10/2
		Preservation	11/5
		Pressure breather valve	10/3
		Pretreatment, special	11/3
		Primed according to corrosivity category	11/3
		Protection cover	9/42
		Proximity switch	10/3
M		R	
Manual Collection	11/7	Radial force, available	2/9
Mass acceleration factor	2/6	Radial force, permissible	2/9
Modular system, bevel gearbox	1/13	Radially reinforced output shaft bearings	9/42
Modular system, helical gearbox	1/11	RAL color	11/4
Modular system, helical worm gearbox	1/15	Rating plate	11/6
Modular system, parallel shaft gearbox	1/12	Reinforced bearings	9/42
Modular system, worm gearbox	1/16	Required torque	2/7
Motor shaft without feather key	10/3	Roller bearing grease	9/43
Mounting	9/34		
Mounting position	9/2		
Mounting types	9/34		
N			
Noise	1/19		
Noise level	1/19		
Notes on dimensional drawings	1/18		
Notes on selection tables	1/17		

	Chapter/Page		Chapter/Page
S		T	
Seal for increased environmental stress	9/43	Technical specifications, general	1/19
Seal with longer service life	9/43	Test certificates	11/7
Service factor	2/5	Torque arm	9/37, 9/38
Shaft designs	9/39	Torque table, structure	1/17
Shaft load	2/9	Torque, required	2/7
Shaft-mounted design	9/37, 9/38	Type designations of the adapters	1/10
Short adapter K4 and K5	8/2	Type designations of the gearboxes	1/10
SIMOGEAR Configurator	1/7		
SIMOGEAR gearboxes	1/2	U	
SIMOLOC assembly system	9/41, 4/126, 5/134, 6/66	Unpainted	11/3
Slip clutch with proximity switch	10/3		
Solid shaft	9/39	V	
Solid shaft, both ends	9/39	Venting	9/46
Solid shaft, inches	9/39		
Sound power level	1/19	W	
Special colors	11/4	Water drain holes at the output flange	9/36
Special order versions	1/8	Worm gearboxes	7/1
Special pretreatment	11/3		
Speed monitoring	10/3		
Splashing losses	2/4		
Splined hollow shaft	9/39		
Structure of the Article No.	1/8		
Structure of the tables	1/17		
Surface pretreatment	11/3		
Surface treatment	11/3		

Appendix

Lists

List of abbreviations

Abbreviation	Meaning	Abbreviation	Meaning
AC	Alternating Current, three-phase	NAT	Rated response temperature
CAD	Computer-Aided Design	NDE	Non-drive end
CCC	China Compulsory Certification	NEE	NEMA Energy Efficient
CEL	China Energy Label	NEMA	National Electrical Manufacturers Association
CEMEP	Comité Européen de Constructeurs de Machines Électriques et d'Électronique de Puissance (European sector committee of manufacturers of electrical machines)	NN	Sea level
CONT	Continuous operation	NPT	National Pipe Thread
CQC	China Quality Certification Center	PAO	Polyalphaolefine
CSA	Canadian Standards Association	PE	Protective Earth, grounding
CT	Coolant temperature	PG	Polyglycol
DC	Direct Current	PTC	Positive Temperature Coefficient
DCF	Duty cycle	SA	Installation altitude
DE:	Drive end	SSI	Simple Sensor Interface
DIN	German Institute for Standardization (DIN)	SW	Width across flats
EBPG	Energy-related products directive	TIA	Totally Integrated Automation
EC	European Community	TIP	Totally Integrated Power
EFF	Efficiency	TTL	Transistor Transistor Logic
EGE	Europäische Größeneinheit	UL-R	Underwriters Laboratories Inc. - Recognition Mark
EISA	Energy Independence and Security Act	VDE	Association of Electrical Engineering, Electronics and Information Technology (Germany)
EMC	Electromagnetic compatibility	VDI	Association of German Engineers
EN	European standard	WGK	Class, signifying risk of water pollution
EPAct	Energy Policy Act		
EU	European Union		
EuP	Energy Using Products		
FVA	Forschungsvereinigung Antriebstechnik e. V. (Research Association for Drive Technology)		
GOST-R	Gossudarstwenny Standart (certification for the Russian Federation)		
HF	High frequency		
HTL	High Transistor Logic		
IEC	International Electrotechnical Commission		
IP	International Protection		
ISO	International Organization for Standardization		
MODULOG	Modular logistically optimized design (motor)		

You benefit from practical training right from the manufacturer

SITRAIN Training for Industry provides you with comprehensive support in solving your tasks.

Training right from the manufacturer enables you to make better choices with more confidence in your decision-making processes.

SITRAIN Training means:

- Less time for commissioning, maintenance and servicing
- Optimized production operations
- Safe engineering and commissioning
- Shorter start-up times, reduced downtimes and faster fault clearance
- Swift elimination of deficits in existing plants
- Avoidance of costly planning errors right from the start
- Flexible plant adaptation to market requirements
- Ensure quality standards in production
- Increased employee satisfaction and motivation
- Shorter orientation periods in case of technology or personnel change



Contact

Visit our website at:

www.siemens.com/sitrain

or let us advise you personally. You can request our latest training catalog from:

SITRAIN – Training for Industry Customer Support Germany:

Phone: +49 911 895-7575

Fax: +49 911 895-7576

E-mail: info@sitrain.com



Important key data

Top trainers

Our trainers are skilled specialists with direct and extensive practical experience. Course developers have close contact with product development and directly pass on their knowledge to the trainers, and with that at the end to you.

Practical experience

Practice makes perfect – that's why we attach greatest importance to hands-on learning. Practical exercises can comprise up to half of the course time. You can therefore immediately implement your new knowledge in your day-to-day work.

300 courses in 62 countries

We offer a total of about 300 local attendance courses. You can find us at more than 50 locations in Germany, and in 62 countries worldwide. To find out which course is held at which location, go to:

www.siemens.com/sitrain

Customized training

Would you prefer individual training instead? Our solution: We will provide a program tailored exactly to your personal requirements. Training can be carried out in our Training Centers or onsite at your company.

We instruct you using state-of-the-art training equipment which has been especially designed by our developers for the SITRAIN courses. This training approach will give you all the assurance you need.

The right mixture: Blended learning

Blended learning involves a combination of various training media. For example, a face-to-face course in a training center can be optimally supplemented by teach-yourself Web-based training (WBT) courses as preparation or follow-up. The add-on effect: Reduced traveling costs and periods of absence.



Appendix

Partner at Siemens

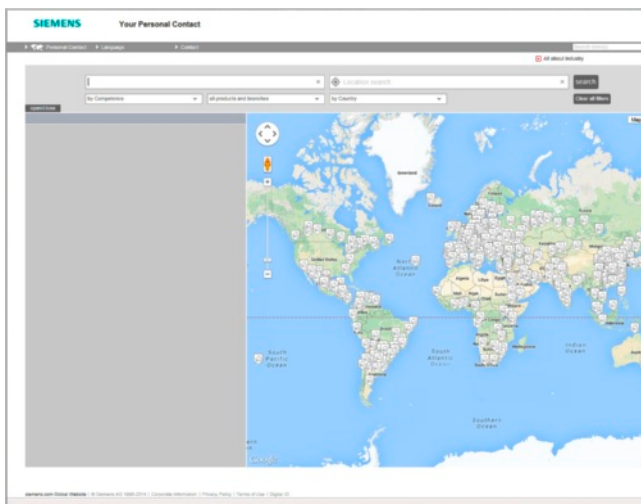

At Siemens we are resolutely pursuing the same goal: long-term improvement of your competitive ability.

We are committed to this goal. Thanks to our commitment, we continue to set new standards in automation and drive technology. In all industries – worldwide.

At your service locally, around the globe for consulting, sales, training, service, support, spare parts ... on the entire Industry Automation and Drive Technologies range.

Your personal contact can be found in our Contacts Database at: www.siemens.com/automation/partner

You start by selecting

- the required competence,
- products and branches,
- a country,
- a city

or by a

- location search or
- person search.

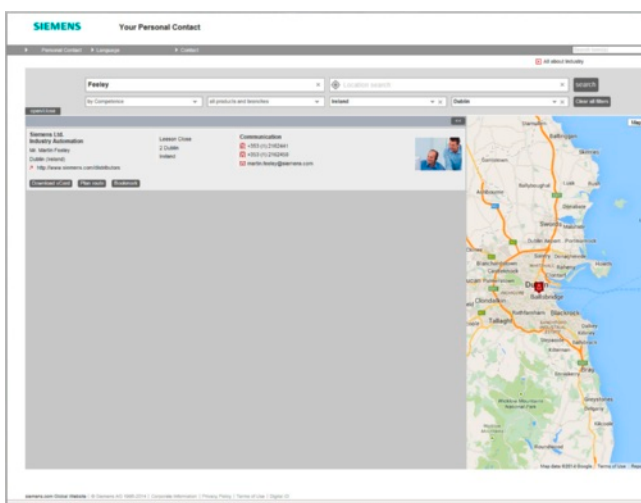
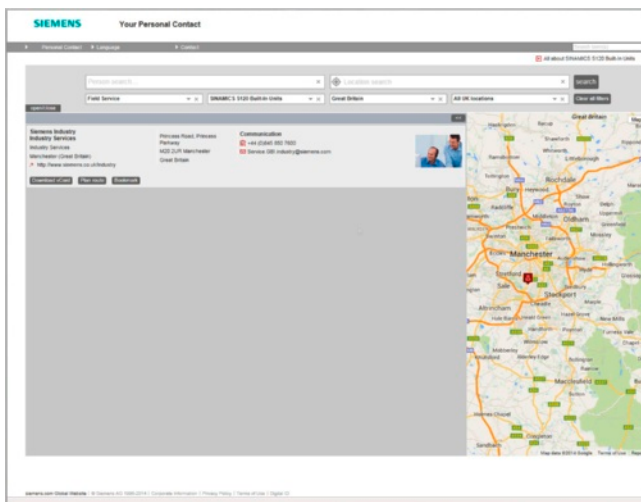

Information and Ordering Options on the Internet and DVD

The Future of Manufacturing in the WWW



Detailed knowledge of the range of products and services available is essential when planning and engineering automation systems. It goes without saying that this information must always be as up-to-date as possible.

Industry is on the threshold of the fourth industrial revolution as digitization now follows after the automation of production. The goals are to increase productivity and efficiency, speed, and quality. In this way, companies can remain competitive on the path to the future of industry.

You will find everything you need to know about products, systems and services on the internet at:

www.siemens.com/industry

Product Selection Using the Interactive CA 01 Automation and Drives Catalog

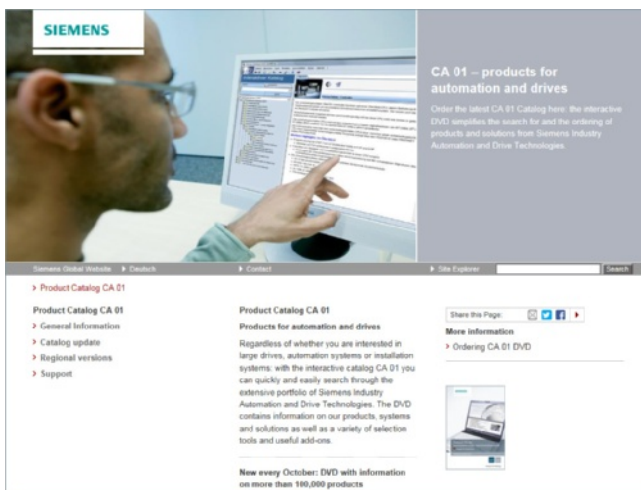

Detailed information together with user-friendly interactive functions:

The CA 01 interactive catalog covers more than 100,000 products, thus providing a comprehensive overview of the product range provided by Siemens.

You will find everything you need here for solving tasks in the fields of automation, switching, installation and drives. All information is provided over a user interface that is both user-friendly and intuitive.

You can order the CA 01 product catalog from your Siemens sales contact or in the Information and Download Center:

www.siemens.com/industry/infocenter

Information about the CA 01 interactive catalog can be found on the Internet at:

www.siemens.com/automation/ca01

or on DVD.

Easy Shopping with the Industry Mall

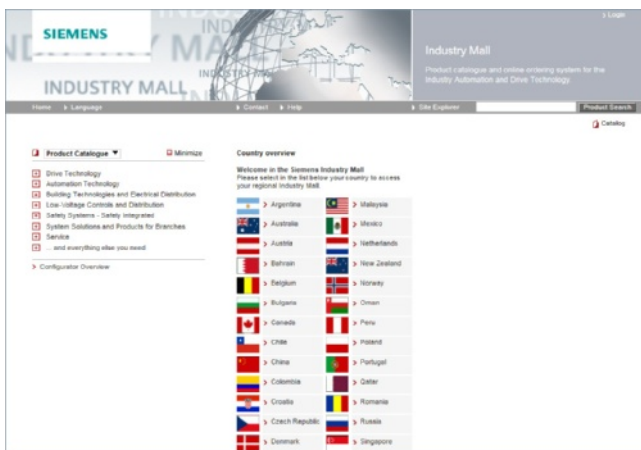

The Industry Mall is the electronic ordering platform of Siemens AG on the Internet. Here you have online access to a huge range of products presented in an informative and attractive way.

Data transfer via EDIFACT allows the whole procedure, from selection through ordering to tracking and tracing, to be carried out online. Availability checks, customer-specific discounts and bid creation are also possible.

Numerous additional functions are provided for your support. For example, powerful search functions make it easy to select the required products. Configurators enable you to configure complex product and system components quickly and easily. CAx data types are also provided here.

You can find the Industry Mall on the Internet at:

www.siemens.com/industrymall

Appendix

Online Services

Information and Download Center, Social Media, Mobile Media

Downloading Catalogs

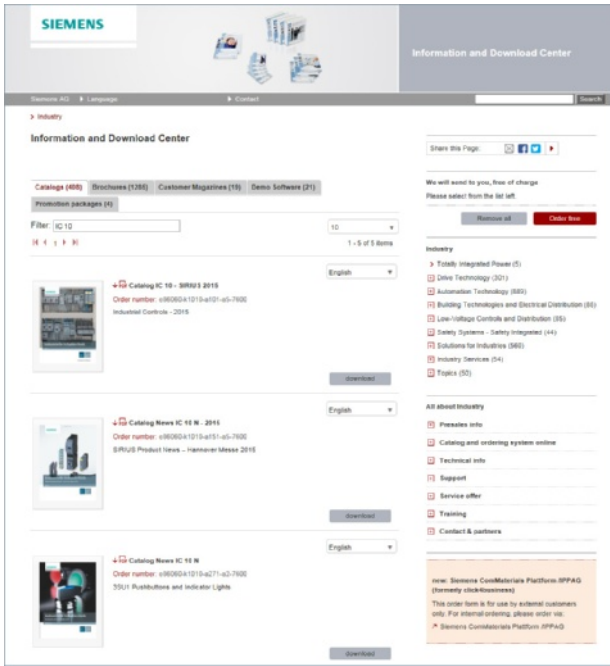

In addition to numerous other useful documents, you can also find the catalogs listed on the back inside cover of this catalog in the Information and Download Center. You can download these catalogs in PDF format without having to register.

The filter dialog above the first catalog displayed makes it possible to carry out targeted searches. If you enter "MD 3" for example, you will find both the MD 30.1 and MD 31.1 catalogs. If you enter "IC 10", both the IC 10 catalog and the associated news or add-ons are displayed.

Visit us at:

www.siemens.com/industry/infocenter

Social and Mobile Media

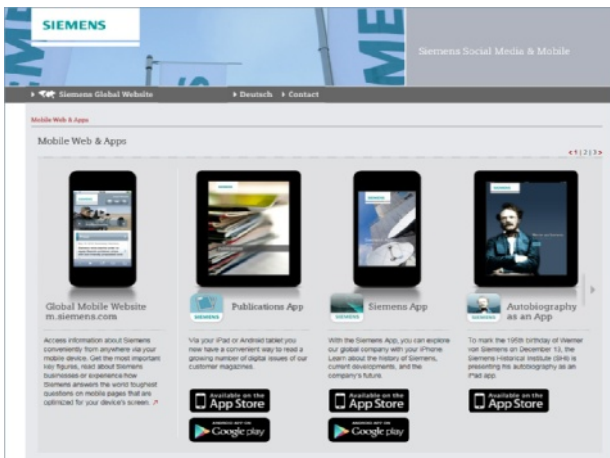

Connect with Siemens through social media: visit our social networking sites for a wealth of useful information, demos on products and services, the opportunity to provide feedback, to exchange information and ideas with customers and other Siemens employees, and much, much more. Stay in the know and follow us on the ever-expanding global network of social media.

To find out more about Siemens' current social media activities, visit us at:

www.siemens.com/socialmedia

Or via our product pages at:

www.siemens.com/automation or www.siemens.com/drives

Connect with Siemens Industry at our central access point to read all the news on the future of manufacturing, watch current videos and inform yourself about all the latest industry developments:

www.siemens.com/future-of-manufacturing/news.html

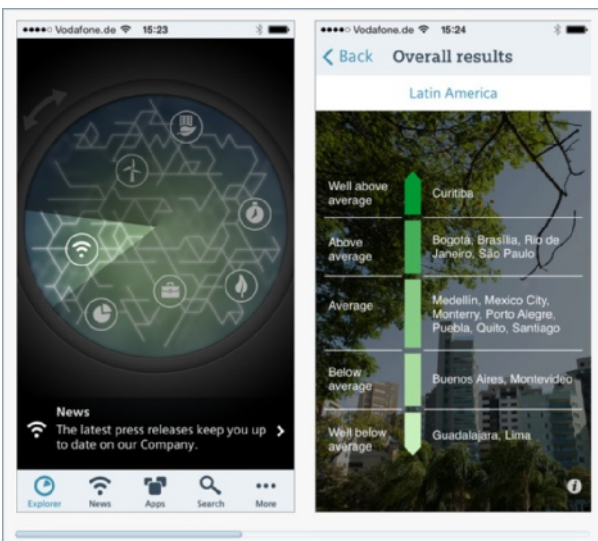

Discover the world of Siemens.

We are also constantly expanding our offering of cross-platform apps for smartphones and tablets. You will find the current Siemens apps at the App Store (iOS) or at Google Play (Android):

<https://itunes.apple.com/en/app/siemens/id452698392?mt=8>

<https://play.google.com/store/search?q=siemens>

The Siemens app, for example, tells you all about the history, latest developments and future plans of the company – with informative pictures, fascinating reports and the most recent press releases.

Your machines and plant can do more – with Industry Services.



Whether it is production or process industry - in view of rising cost pressure, growing energy costs, and increasingly stringent environmental regulations, services for industry are a crucial competitive factor in manufacturing as well as in process industries.

All over the world Siemens supports its customers with product, system, and application-related services throughout the entire life cycle of a plant. Right from the earliest stages of planning, engineering, and building, all the way to operation and modernization. These services enable customers to benefit from the Siemens experts' unique technological and product knowledge and industry expertise.

Thus downtimes are reduced and the utilization of resources is optimized. The bottom line: increased plant productivity, flexibility, and efficiency, plus reduced overall costs.

Discover all advantages of our service portfolio:
www.siemens.com/industry-services

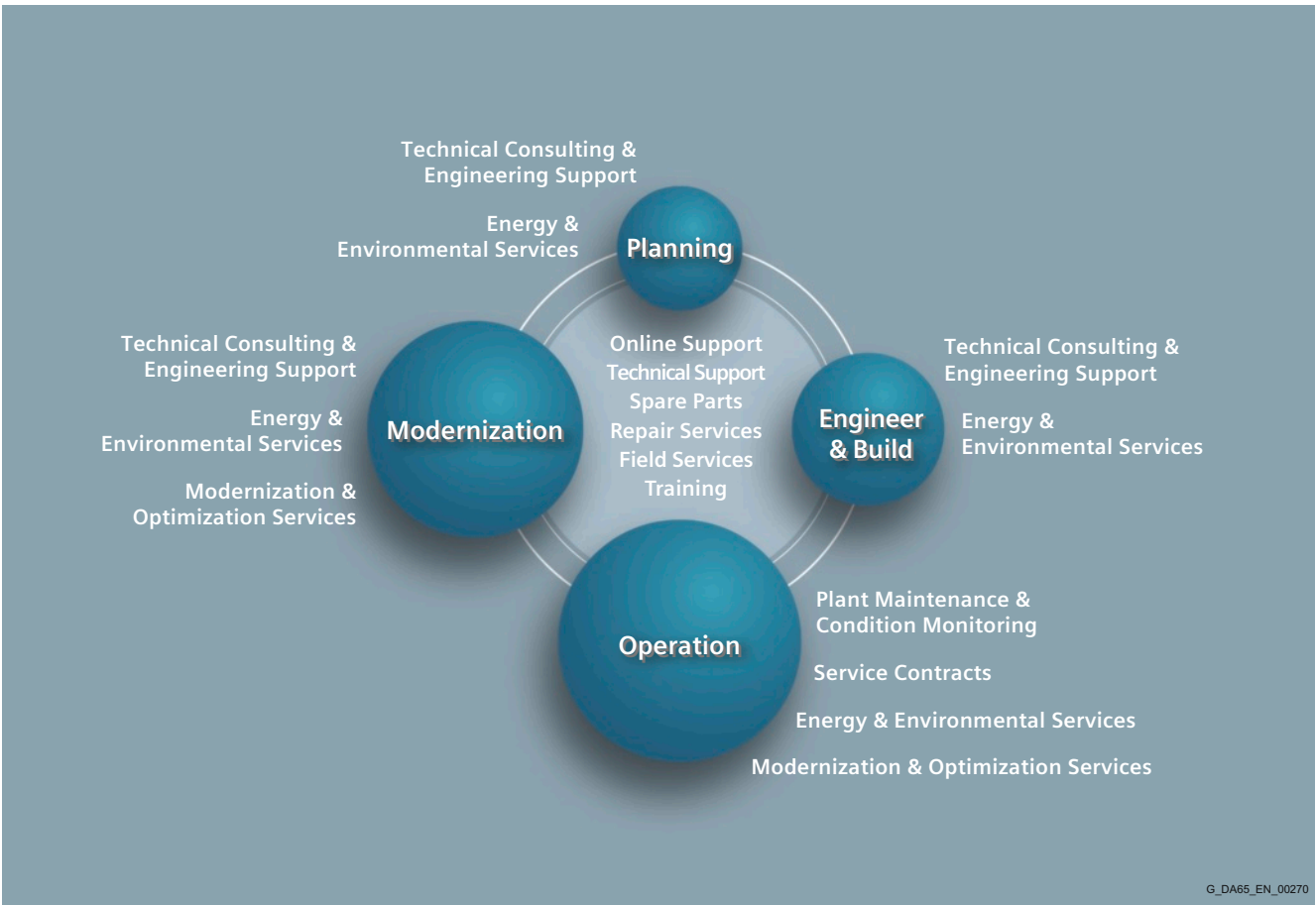

G_DA65_EN_00270

Siemens supports its clients with technology based Services across a plants entire life cycle.

Appendix

Industry Services

Industry Services for the entire life cycle

Online Support

Online support is a comprehensive information system for all questions relating to products, systems, and solutions that Siemens has developed for industry over time. With more than 300,000 documents, examples and tools, it offers users of automation and drive technology a way to quickly find up-to-date information. The 24-hour service enables direct, central access to detailed product information as well as numerous solution examples for programming, configuration and application.

The content, in six languages, is increasingly multimedia based – and now also available as a mobile app. Online support's "Technical Forum" offers users the opportunity to share information with each other. The "Support Request" option can be used to contact Siemens' technical support experts. The latest content, software updates, and news via newsletters and Twitter ensure that industry users are always up to date.



www.siemens.com/industry/onlinesupport

Online Support App



Using the Online Support app, you can access over 300,000 documents covering all Siemens industrial products - anywhere, any time. Regardless of whether you need help implementing your project, fault-finding, expanding your system or are planning a new machine.

You have access to FAQs, manuals, certificates, characteristics curves, application examples, product notices (e.g. announcements of new products) and information on successor products in the event that a product is discontinued.

Just scan the product code printed on the product directly using the camera of your mobile device to immediately see all technical information available on this product at a glance. The graphical CAx information (3D model, circuit diagrams or EPLAN macros) is also displayed. You can forward this information to your workplace using the e-mail function.

The search function retrieves product information and articles and supports you with a personalized suggestion list. You can find your favorite pages – articles you need frequently – under

"mySupport". You also receive selected news on new functions, important articles or events in the News section.

Scan the QR code
for information on
our Online Support
app.



The app is available free of charge from the Apple App Store (iOS) or from Google Play (Android).

www.siemens.com/industry/onlinesupportapp

Technical Support

The ability to quickly analyze system and error messages and take appropriate action are key factors in ensuring that plants run safely and efficiently. Questions can arise at any time and in any industry, whether it's an individual product or a complete automation solution. Siemens technical support offers individual technical assistance in matters related to functionality, how to operate, applications, and fault clearance in industrial products and systems – at any time and globally, over the phone, by e-mail, or via remote access. Experienced experts from Siemens answer incoming questions promptly. Depending on the requirements, they first consult specialists in the areas of development, on-site services, and sales. Technical support is also available for discontinued products that are no longer available. Using the support request number, any inquiry can be clearly identified and systematically tracked.

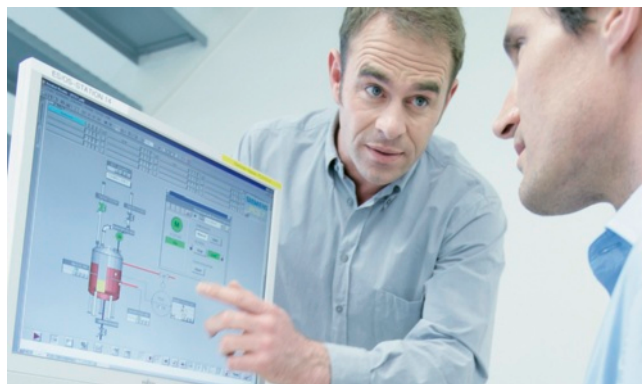

Spare Parts

Drive and automation systems must be available at all times. Even a single missing spare part can bring the entire plant to a standstill – and result in substantial financial losses for the operator. The spare parts services from Siemens protect against such losses – with the aid of quickly available, original spare parts that ensure smooth interaction with all other system components. Spare parts are kept on hand for up to ten years; defective parts can be returned. For many products and solutions, individual spare parts packages ensure a preventive stock of spare parts on-site. The spare parts service is available around the world and around the clock. Optimum supply chain logistics ensure that replacement components reach their destination as quickly as possible. Siemens' logistics experts take care of planning and management as well as procurement, transportation, customs handling, warehousing, and complete order management for spare parts.



Repair Services

Reliable electrical and electronic equipment is crucial for operating continuous processes. That is why it is essential that motors and converters always undergo highly specialized repair and maintenance. Siemens offers complete customer and repair services – on site and in repair centers – as well as technical emergency services worldwide. The repair services include all measures necessary to quickly restore the functionality of defective units. In addition, services such as spare parts logistics, spare parts storage and rapid manufacturing are available to plant operators in all verticals. With a global network of certified repair shops operated by Siemens as well as third parties, Siemens handles the maintenance and overhaul of motors, converters, and other devices as an authorized service partner.



Field Services

It's a top priority in all industries: the availability of plants and equipment. Siemens offers specialized maintenance services such as inspection and upkeep as well as rapid fault clearance in industrial plants – worldwide, continuously, and even with emergency services as needed. The services include startup as well as maintenance and fault clearance during operation. The startup service includes checking the installation, function tests, parameterization, integration tests for machines and plants, trial operation, final acceptance, and employee training. All services, including remote maintenance of drives, are also available as elements of customized service contracts.



Appendix

Industry Services

Industry Services for the entire life cycle

Training

Increasingly, up-to-date knowledge is becoming a determining factor in success. One of the key resources of any company is well-trained staff that can make the right decision at the right moment and take full advantage of the potential. With SITRAIN – Training for Industry, Siemens offers comprehensive advanced training programs. The technical training courses convey expertise and practical knowledge directly from the manufacturer. SITRAIN covers Siemens' entire product and system portfolio in the field of automation and drives. Together with the customer, Siemens determines the company's individual training needs and then develops an advanced training program tailored to the desired requirements. Additional services guarantee that the knowledge of all Siemens partners and their employees is always up-to-date.



Technical Consulting & Engineering Support

The efficiency of plants and processes leads to sustainable economic success. Individual services from Siemens help save substantial time and money while also guaranteeing maximum safety. Technical consulting covers the selection of products and systems for efficient industrial plants. The services include planning, consulting, and conceptual design as well as product training, application support, and configuration verification – in all phases of a plant's lifecycle and in all questions related to product safety. Engineering support offers competent assistance throughout the entire project, from developing a precise structure for startup to product-specific preparation for implementation as well as support services in areas such as prototype development, testing and acceptance.



Energy & Environmental Services

Efficient energy use and resource conservation – these top sustainability concerns pay off – both for the environment and for companies. Siemens offers integrated solutions that unlock all technical and organizational potential for successful environmental management. Customized consulting services are aimed at sustainably lowering the cost of energy and environmental protection and thus increasing plant efficiency and availability. The experts provide support in the conceptual design and implementation of systematic solutions in energy and environmental management, enabling maximum energy efficiency and optimized water consumption throughout the entire company. Improved data transparency makes it possible to identify savings potential, reduce emissions, optimize production processes, and thereby noticeably cut costs.



Modernization & Optimization Services

High machine availability, expanded functionality and selective energy savings – in all industries, these are decisive factors for increasing productivity and lowering costs. Whether a company wants to modernize individual machines, optimize drive systems, or upgrade entire plants, Siemens' experts support the projects from planning to commissioning.

Expert consulting and project management with solution responsibility lead to security and make it possible to specifically identify savings potential in production. This secures investments over the long term and increases economic efficiency in operation.



Plant Maintenance & Condition Monitoring

Modern industrial plants are complex and highly automated. They must operate efficiently in order to ensure the company's competitive strength. In addition, the steadily increasing networking of machines and plants require consistent security concepts. Maintenance and status monitoring as well as the implementation of integrated security concepts by Siemens' experts support optimum plant use and avoid downtime. The services include maintenance management as well as consulting on maintenance concepts, including the complete handling and execution of the necessary measures. Complete solutions also cover remote services, including analysis, remote diagnosis, and remote monitoring. These are based on the Siemens Remote Services platform with certified IT security.



Service Contracts

Making maintenance costs calculable, reducing interfaces, speeding up response times, and unburdening the company's resources – the reduced downtimes that these measures achieve increase the productivity of a plant. Service contracts from Siemens make maintenance and repairs more cost-effective and efficient. The service packages include local and remote maintenance for a system or product group in automation and drive technology. Whether you need extended service periods, defined response times, or special maintenance intervals, the services are compiled individually and according to need. They can be adjusted flexibly at any time and used independently of each other. The expertise of Siemens' specialists and the capabilities of remote maintenance thus ensure reliable and fast maintenance processes throughout a plant's entire lifecycle.



Appendix

Notes

Appendix

Conditions of sale and delivery

1. General Provisions

By using this catalog you can acquire hardware and software products described therein from Siemens AG subject to the following Terms and Conditions of Sale and Delivery (hereinafter referred to as "T&C"). Please note that the scope, the quality and the conditions for supplies and services, including software products, by any Siemens entity having a registered office outside Germany, shall be subject exclusively to the General Terms and Conditions of the respective Siemens entity. The following T&C apply exclusively for orders placed with Siemens Aktiengesellschaft, Germany.

1.1 For customers with a seat or registered office in Germany

For customers with a seat or registered office in Germany, the following applies subordinate to the T&C:

- the "General Terms of Payment"¹⁾ and,
- for software products, the "General License Conditions for Software Products for Automation and Drives for Customers with a Seat or Registered Office in Germany"¹⁾ and,
- for other supplies and services, the "General Conditions for the Supply of Products and Services of the Electrical and Electronics Industry"¹⁾.

1.2 For customers with a seat or registered office outside Germany

For customers with a seat or registered office outside Germany, the following applies subordinate to the T&C:

- the "General Terms of Payment"¹⁾ and,
- for software products, the "General License Conditions for Software Products for Automation and Drives for Customers with a Seat or Registered Office outside of Germany"¹⁾ and
- for other supplies and/or services, the "General Conditions for Supplies of Siemens Industry for Customers with a Seat or Registered Office outside of Germany"¹⁾.

2. Prices

The prices are in € (Euro) ex point of delivery, exclusive of packaging.

The sales tax (value added tax) is not included in the prices. It shall be charged separately at the respective rate according to the applicable statutory legal regulations.

Prices are subject to change without prior notice. We will charge the prices valid at the time of delivery.

To compensate for variations in the price of raw materials (e.g. silver, copper, aluminum, lead, gold, dysprosium and neodym), surcharges are calculated on a daily basis using the so-called metal factor for products containing these raw materials. A surcharge for the respective raw material is calculated as a supplement to the price of a product if the basic official price of the raw material in question is exceeded.

The metal factor of a product indicates the basic official price (for those raw materials concerned) as of which the surcharges on the price of the product are applied, and with what method of calculation.

An exact explanation of the metal factor can be downloaded at:

www.siemens.com/automation/salesmaterial-as/catalog/en/terms_of_trade_en.pdf

To calculate the surcharge (except in the cases of dysprosium and neodym), the official price from the day prior to that on which the order was received or the release order was effected is used.

To calculate the surcharge applicable to dysprosium and neodym ("rare earths"), the corresponding three-month basic average price in the quarter prior to that in which the order was received or the release order was effected is used with a one-month buffer (details on the calculation can be found in the explanation of the metal factor).

3. Additional Terms and Conditions

The dimensions are in mm. In Germany, according to the German law on units in measuring technology, data in inches apply only to devices for export.

Illustrations are not binding.

Insofar as there are no remarks on the individual pages of this catalog - especially with regard to data, dimensions and weights given - these are subject to change without prior notice.

4. Export regulations

We shall not be obligated to fulfill any agreement if such fulfillment is prevented by any impediments arising out of national or international foreign trade or customs requirements or any embargoes and/or other sanctions.

Export of goods listed in this catalog may be subject to licensing requirements. We will indicate in the delivery details whether licenses are required under German, European and US export lists. Goods labeled with "AL" not equal to "N" are subject to European or German export authorization when being exported out of the EU. Goods labeled with "ECCN" not equal to "N" are subject to US re-export authorization.

The export indications can be viewed in advance in the description of the respective goods on the Industry Mall, our online catalog system. Only the export labels "AL" and "ECCN" indicated on order confirmations, delivery notes and invoices are authoritative.

Even without a label, or with label "AL:N" or "ECCN:N", authorization may be required i .a. due to the final disposition and intended use of goods.

If you transfer goods (hardware and/or software and/or technology as well as corresponding documentation, regardless of the mode of provision) delivered by us or works and services (including all kinds of technical support) performed by us to a third party worldwide, you must comply with all applicable national and international (re-)export control regulations.

If required for the purpose of conducting export control checks, you (upon request by us) shall promptly provide us with all information pertaining to the particular end customer, final disposition and intended use of goods delivered by us respectively works and services provided by us, as well as to any export control restrictions existing in this relation.

The products listed in this catalog may be subject to European/German and/or US export regulations. Any export requiring approval is therefore subject to authorization by the relevant authorities.

Errors excepted and subject to change without prior notice.

1) The text of the Terms and Conditions of Siemens AG can be downloaded at www.siemens.com/automation/salesmaterial-as/catalog/en/terms_of_trade_en.pdf

Further information can be obtained from our branch offices listed at www.siemens.com/automation/partner

Interactive Catalog on DVD Products for Automation and Drives	<i>Catalog</i> CA 01	Low-Voltage Power Distribution and Electrical Installation Technology	<i>Catalog</i>
Building Control GAMMA Building Control	ET G1	SETRON · SIVACON · ALPHA Protection, Switching, Measuring and Monitoring Devices, Switchboards and Distribution Systems	LV 10
Drive Systems SINAMICS G130 Drive Converter Chassis Units	D 11	Standards-Compliant Components for Photovoltaic Plants	LV 11
SINAMICS G150 Drive Converter Cabinet Units		Electrical Components for the Railway Industry	LV 12
SINAMICS GM150, SINAMICS SM150 Medium-Voltage Converters	D 12	<i>Digital: TÜV-certified Power Monitoring System</i>	LV 14
SINAMICS PERFECT HARMONY GH180 Medium-Voltage Air-Cooled Drives Germany Edition	D 15.1	Components for Industrial Control Panels according to UL Standards	LV 16
SINAMICS G180 Converters – Compact Units, Cabinet Systems, Cabinet Units Air-Cooled and Liquid-Cooled	D 18.1	3WT Air Circuit Breakers up to 4000 A	LV 35
SINAMICS S120 Chassis Format Units and Cabinet Modules	D 21.3	3VT Molded Case Circuit Breakers up to 1600 A	LV 36
SINAMICS S150 Converter Cabinet Units		<i>Digital: SIVACON System Cubicles, System Lighting and System Air-Conditioning</i>	LV 50
SINAMICS DCM DC Converter, Control Module	D 23.1	<i>Digital: ALPHA Distribution Systems</i>	LV 51
SINAMICS DCM Cabinet	D 23.2	ALPHA FIX Terminal Blocks	LV 52
SINAMICS Inverters for Single-Axis Drives and SIMOTICS Motors	D 31	SIVACON S4 Power Distribution Boards	LV 56
SINAMICS G120P and SINAMICS G120P Cabinet pump, fan, compressor converters	D 35	SIVACON 8PS Busbar Trunking Systems	LV 70
Three-Phase Induction Motors SIMOTICS HV, SIMOTICS TN	D 84.1	<i>Digital: DELTA Switches and Socket Outlets</i>	ET D1
• Series H-compact		Motion Control	
• Series H-compact PLUS		SINUMERIK 840D sl Type 1B Equipment for Machine Tools	NC 62
Three-Phase Induction Motors SIMOTICS HV, Series H-compact	D 86.1	SINUMERIK 808 Equipment for Machine Tools	NC 81.1
Synchronous Motors with Permanent-Magnet Technology, HT-direct	D 86.2	SINUMERIK 828 Equipment for Machine Tools	NC 82
DC Motors	DA 12	SIMOTION, SINAMICS S120 & SIMOTICS Equipment for Production Machines	PM 21
SIMOREG DC MASTER 6RA70 Digital Chassis Converters	DA 21.1	Drive and Control Components for Cranes	CR 1
SIMOREG K 6RA22 Analog Chassis Converters	DA 21.2	Power Supply	
<i>Digital: SIMOREG DC MASTER 6RM70 Digital Converter Cabinet Units</i>	DA 22	SITOP Power supply	KT 10.1
SIMOVERT PM Modular Converter Systems	DA 45	Safety Integrated	
SIEMOSYN Motors	DA 48	Safety Technology for Factory Automation	SI 10
MICROMASTER 420/430/440 Inverters	DA 51.2	SIMATIC HMI / PC-based Automation	
MICROMASTER 411/COMBIMASTER 411	DA 51.3	Human Machine Interface Systems/ PC-based Automation	ST 80/ ST PC
SIMODRIVE 611 universal and POSMO	DA 65.4	SIMATIC Ident	
<i>Note: Additional catalogs on the SINAMICS drive system and SIMOTICS motors with SINUMERIK and SIMOTION can be found under Motion Control</i>		Industrial Identification Systems	ID 10
Low-Voltage Three-Phase-Motors		SIMATIC Industrial Automation Systems	
SIMOTICS Low-Voltage Motors	D 81.1	Products for Totally Integrated Automation	ST 70
SIMOTICS FD Flexible Duty Motors	D 81.8	SIMATIC PCS 7 Process Control System	ST PCS 7
LOHER Low-Voltage Motors	D 83.1	System components	
MOTOX Geared Motors	D 87.1	SIMATIC PCS 7 Process Control System Technology components	ST PCS 7 T
SIMOGEAR Geared Motors	MD 50.1	Add-ons for the SIMATIC PCS 7 Process Control System	ST PCS 7 AO
SIMOGEAR Gearboxes with adapter	MD 50.11	SIMATIC NET	
Mechanical Driving Machines		Industrial Communication	IK PI
FLENDER Standard Couplings	MD 10.1	SIRIUS Industrial Controls	
FLENDER High Performance Couplings	MD 10.2	SIRIUS Industrial Controls	IC 10
FLENDER Backlash-free Couplings	MD 10.3		
FLENDER SIG Standard industrial gear units	MD 30.1		
FLENDER SIP Standard industrial planetary gear units	MD 31.1		
Process Instrumentation and Analytics			
<i>Digital: Field Instruments for Process Automation</i>	FI 01		
<i>Digital: SIPART Controllers and Software</i>	MP 31		
Products for Weighing Technology	WT 10		
<i>Digital: Process Analytical Instruments</i>	AP 01		
<i>Digital: Process Analytics, Components for the System Integration</i>	PA 11		
<i>Digital: These catalogs are only available as a PDF.</i>			
		Information and Download Center	
		Digital versions of the catalogs are available on the Internet at: www.siemens.com/industry/infocenter	
		There you'll find additional catalogs in other languages.	
		Please note the section "Downloading catalogs" on page "Online services" in the appendix of this catalog.	

Siemens AG
Digital Factory
Motion Control
Geared Motors
Postfach 1709
72007 Tübingen
GERMANY

Subject to change without prior notice
Article No. E86060-K5250-A211-A3-7600
E.9115.OO.LDT / Dispo 18409
KG 0915 3.0 PAS 600 En
Printed in Germany
© Siemens AG 2015

The information provided in this catalog contains merely general descriptions or characteristics of performance which in case of actual use do not always apply as described or which may change as a result of further development of the products. An obligation to provide the respective characteristics shall only exist if expressly agreed in the terms of contract. Availability and technical specifications are subject to change without notice.

All product designations may be trademarks or product names of Siemens AG or supplier companies whose use by third parties for their own purposes could violate the rights of the owners.