

FLENDER COUPLINGS  
CATALOG **FLE 10.2**  
EDITION 2023.1 EN



FLEXIBLE COUPLINGS  
N-EUPEX, RUPEX AND N-BIPEX

# INTRODUCTION

E

The mechanical drive train comprises individual units such as motor, gear unit and driven machine. The coupling connects these component assemblies.

As well as the transmission of rotary motion and torque, other requirements may be made of the coupling.

- Compensation for shaft misalignment with low restorative forces
- Control of characteristic angular vibration frequency and damping
- Interruption or limitation of torque
- Noise insulation, electrical insulation

Couplings are frequently chosen after the machines to be connected have already been selected. Thanks to a large number of different coupling assembly options, specified marginal conditions for clearance and connection geometry can be met from the standard range. The coupling also performs secondary functions, e.g. providing a brake disk or brake drum for operating or blocking brakes, devices to record speed or the attachment of sprockets or pulleys.

Couplings are divided into two main groups, couplings and clutches.

Clutches interrupt or limited the transmissible torque. The engaging and disengaging forces on externally operated clutches are introduced via a mechanically, electrically, hydraulically or pneumatically operating mechanism. Overload, centrifugal or freewheel clutches draw their engaging energy from the transmitted output.

Rigid couplings, designed as clamp, flanged or mechanism couplings, connect machines which must not undergo any shaft misalignment. Hydrodynamic couplings, often also called fluid or Föttinger couplings, are used as starting couplings in drives with high mass moments of inertia of the driven machine. In drive technology very often flexible, positive couplings, which may be designed to be torsionally rigid, torsionally flexible or highly flexible, are used.

Torsionally rigid couplings are designed to be rigid in a peripheral direction and flexible in radial and axial directions. The angle of rotation and torque are conducted through the coupling without a phase shift.

Torsionally flexible couplings have resilient elements usually manufactured from elastomer materials. Using an elastomer material with a suitable ShoreA hardness provides the most advantageous torsional stiffness and damping for the application. Shaft misalignment causes the resilient elements to deform.

Highly flexible couplings have large-volume (elastomer) resilient elements of low stiffness. The angle of rotation and torque are conducted through the coupling with a considerable phase shift.

# TECHNICAL INFORMATION

E

## Shaft misalignment

Shaft misalignment is the result of displacement during assembly and operation and, where machines constructed with two radial bearings each are rigidly coupled, will cause high loads being placed on the bearings. Elastic deformation of base frame, foundation and machine housing will lead to shaft misalignment which cannot be prevented, even by precise alignment.

Furthermore, because individual components of the drive train heat up differently during operation, heat expansion of the machine housings causes shaft misalignment. Poorly aligned drives are often the cause of seal, rolling bearing or coupling failure. Alignment should be carried out by specialist personnel in accordance with operating instructions.

Depending on the direction of the effective shaft misalignment a distinction is made between:

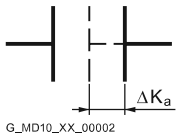

Axial misalignment

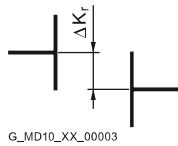

Radial misalignment

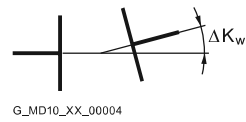

Angular misalignment

Couplings can be categorized into one of the following groups:

### Single-joint couplings

Couplings with flexible elements mainly made of elastomer materials. Shaft misalignment results in deformation of the elastomer elements. The elastomer elements can absorb shaft misalignment as deformations in an axial, radial and angular direction. The degree of permissible misalignment depends on the coupling size, the speed and the type of elastomer element.

Single-joint couplings do not require an adapter and are therefore short versions.

#### Example:

In the case of a RUPLEX RWN 198 coupling with an outer diameter of 198 mm and a speed of 1500 rpm, the permitted radial misalignment is  $\Delta K_r = 0.3 \text{ mm}$ .

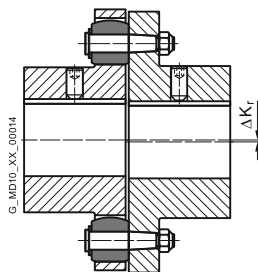

### Two-joint couplings

Two-joint couplings are always designed with an adapter. The two joint levels are able to absorb axial and angular misalignment. Radial misalignment occurs via the gap between the two joint levels and the angular displacement of the joint levels. The permitted angular misalignment per joint level is frequently about 0.5°. The permitted shaft misalignment of the coupling can be adjusted via the length of the adapter. If there are more than two joint levels, it is not possible to define the position of the coupling parts relative to the axis of rotation. (The less frequently used parallel-crank couplings are an exception).

#### Example:

N-ARPEX ARN-6 NEN 217-6 with a shaft distance of 140 mm with a permitted radial misalignment of  $\Delta K_r = 2.2 \text{ mm}$  (angle per joint level 1.0°).

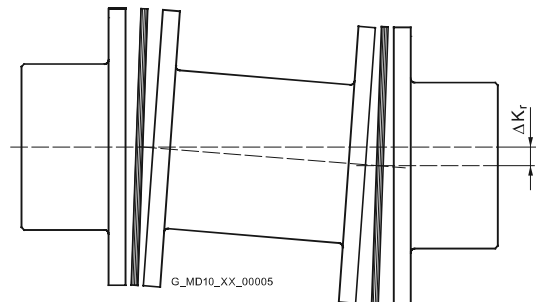

## Balancing

### Balance quality levels

The so-called quality level G to DIN ISO 21940 indicates a range of permitted residual imbalance from zero up to an upper limit. Applications can be grouped on the basis of similarity analysis. For many applications a coupling balance quality of G 16 is sufficient. On drives susceptible to vibration the balance quality should be G 6.3. Only in special cases is a better balance quality required.

### Balancing standard in accordance with DIN ISO 21940-32

Besides the required balance quality, it is necessary to set standards which define how the mass of the parallel key is to be taken into consideration when balancing. In the past, motor rotors have frequently been balanced in accordance with the full parallel key standard. The "appropriate" balance condition of the coupling hub was described as "balancing with open keyway" or "balancing after keyseating". Today it is usual for the motor rotor, as well as the gear unit and driven machine shaft, to be balanced in accordance with the half parallel key standard.

### Full parallel key standard

The parallel key is inserted in the shaft keyway, then balancing is carried out. The coupling hub must be balanced without parallel key after keyseating.

Marking of shaft and hub with "F" (for "full").

### Half parallel key standard

The balancing standard normally applied today. Before balancing, a half parallel key is inserted in the shaft and another in the coupling hub. Alternatively, balancing can be carried out before cutting the keyway.

The balanced parts must be marked with an "H". This marking can be dispensed with if it is absolutely clear which parallel key standard has been applied.

### No parallel key standard

Balancing of shaft and coupling hub after keyseating, but without parallel key. Not used in practice. Marking of shaft and hub with "N" (for "no").

The length of the parallel key is determined by the shaft keyway. Coupling hubs may be designed considerably shorter than the shaft.

To prevent imbalance forces caused by projecting parallel key factors when balancing in accordance with the half parallel key standard in the case of applications with high balancing quality requirements, grooved spacer rings can be fitted or stepped parallel keys used.

### Flender Balancing Standard

The balancing quality level, together with the operating speed, results in the maximum permissible eccentricity of the center of gravity of the coupling or the coupling subassembly. In the Flender article number the balancing quality can be preset with the help of the order code. Additionally, also the balance quality level to DIN ISO 21940 can be preset together with the operating speed belonging to it, which then be taken as priority.

$$e_{perm} = 9550 \cdot \frac{G}{n}$$

$$e_{coupl} \leq e_{perm}$$

Permitted eccentricity of center of gravity  $e_{perm}$  in  $\mu\text{m}$   
 Eccentricity of center of gravity of coupling  $e_{coupl}$  in  $\mu\text{m}$   
 Balancing quality level  $G$  in mm/s  
 Coupling speed  $n$  in rpm

Eccentricity of center of gravity of coupling $e_{coupl}$	Flender balancing quality	Order code
maximum 100 $\mu\text{m}$	standard balancing	without specification
maximum 40 $\mu\text{m}$	fine balancing	W02
maximum 16 $\mu\text{m}$	micro-balancing	W03
better than 16 $\mu\text{m}$	special balancing	on request



# TECHNICAL INFORMATION

E

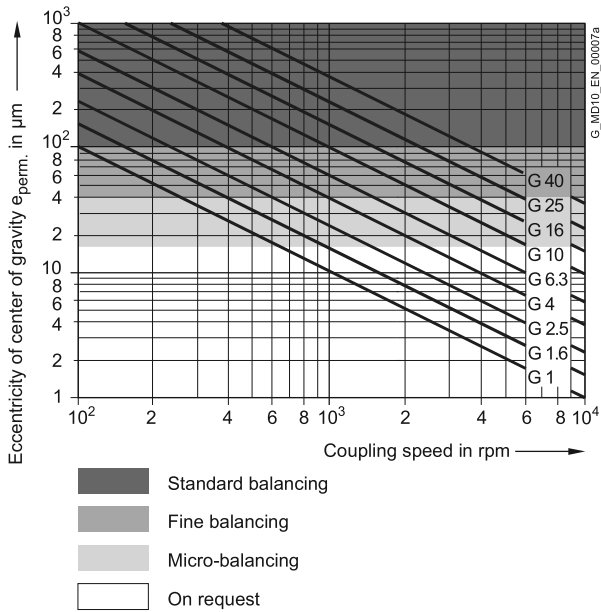

Example:  
Coupling speed = 1450 rpm  
required balancing quality level G 6.3

$$e_{perm} = 9550 \cdot \frac{G}{n} = 9550 \cdot \frac{6.3}{1450} \mu\text{m}$$

Thus, the required eccentricity of center of gravity is 41.5 µm. The fine balancing with a maximum eccentricity of center of gravity of 40 mm fulfills this requirement; therefore, the order code W02 has to be specified when ordering.

For many applications the following balancing quality recommendation applies:

Coupling	standard balancing $v = DA \cdot n/19100$	fine balancing
short version with $LG \leq 3 \times DA$	$v \leq 30 \text{ m/s}$	$v > 30 \text{ m/s}$
long version with $LG > 3 \times DA$	$v \leq 15 \text{ m/s}$	$v > 15 \text{ m/s}$

Peripheral speed	$v$	in mm/s
Coupling outer diameter	DA	in mm
Coupling speed	$n$	in rpm
Coupling length	LG	in mm

The following standards on balancing must be observed:

- couplings are balanced in subassemblies.
- hub parts without finished bore are unbalanced.
- the number of balancing levels (one- or two-level balancing) is specified by Flender.
- without special specification balancing is done in accordance with the half-parallel-key standard. Balancing in accordance with the full-parallel-key standard must be specified in the order number.
- For FLUDEX couplings special balancing standards specified in Section 13 apply.
- ARPEX couplings in standard balancing quality are unbalanced. Thanks to steel components machined all over and precisely guided adapters the balancing quality of standard balancing is nearly always adhered to.

## Shaft-hub connections

---

The bore and the shaft-hub connection of the coupling are determined by the design of the machine shaft. In the case of IEC standard motors, the shaft diameters and parallel key connections are specified in accordance with DIN EN 50347. For diesel motors, the flywheel connections are frequently specified in accordance with SAE J620d or DIN 6288. Besides the very widely used connection of shaft and hub with parallel keys to DIN 6885 and cylindrically bored hubs, couplings with Taper clamping bushes, clamping sets, shrink-fit connections and splines to DIN 5480 are common.

The form stability of the shaft/hub connection can only be demonstrated when shaft dimensions and details of the connection are available. The coupling torques specified in the tables of power ratings of the coupling series do not apply to the shaft-hub connection unrestrictedly.

In the case of the shaft-hub connection with parallel key, the coupling hub must be axially secured, e.g. with a set screw or end washer. The parallel key must be secured against axial displacement in the machine shaft.

All Flender couplings with a finished bore and parallel keyway are designed with a set screw. Exceptions are some couplings of the FLUDEX series, in which end washers are used. During assembly, Taper clamping bushes are frictionally connected to the machine shaft.

# TECHNICAL INFORMATION

E

## Standards

### Machines

2006/42/EG	EC Machinery Directive
2014/34/EU	ATEX Directive – Manufacturer
1999/92/EG	ATEX Directive – Operator – and ATEX Guideline to Directive 1999/92/EC
DIN EN 80079-36	Non-electrical equipment for use in potentially explosive atmospheres
DIN EN 1127	Explosive atmospheres, explosion prevention and protection
DIN EN 50347	General-purpose three-phase induction motors having standard dimensions and outputs

### Couplings

DIN 740	Flexible shaft couplings Part 1 and Part 2
VDI Guideline 2240	Shaft couplings - Systematic subdivision according to their properties VDI Technical Group Engineering Design 1971
API 610	Centrifugal Pumps for Petroleum, Chemical and Gas Industry Services
API 671	Special Purpose Couplings for Petroleum, Chemical and Gas Industry Services
ISO 10441	Petroleum, petrochemical and natural gas industries – Flexible couplings for mechanical power transmission-special-purpose applications
ISO 13709	Centrifugal pumps for petroleum, petrochemical and natural gas industries

### Balancing

DIN ISO 21940	Requirements for the balancing quality of rigid rotors
DIN ISO 21940-32	Mechanical vibrations; standard governing the type of parallel key during balancing of shafts and composite parts

### Shaft-hub connections

DIN 6885	Driver connections without taper action – parallel keys – keyways
SAE J620d	Flywheels for industrial engines ...
DIN 6288	Reciprocating internal combustion engines Dimensions and requirements for flywheels and flexible couplings
ASME B17.1	Keys and keyseats
DIN EN 50347	General-purpose three-phase induction motors with standard dimensions and output data
BS 46-1:1958	Keys and keyways and taper pins Specification

## Key to symbols

Name	Symbols	Unit	Explanation
Torsional stiffness, dynamic	$C_{Tdyn}$	Nm/rad	For calculating torsional vibration
Excitation frequency	$f_{err}$	Hz	Excitation frequency of motor or driven machine
Moment of inertia	$J$	kgm <sup>2</sup>	Moment of inertia of coupling sides 1 and 2
Axial misalignment	$\Delta K_a$	mm	Axial misalignment of the coupling halves
Radial misalignment	$\Delta K_r$	mm	Radial misalignment of the coupling halves
Angular misalignment	$\Delta K_w$	°	Angular misalignment of the coupling halves
Service factor	FB		Factor expressing the real coupling load as a ratio of the nominal coupling load
Frequency factor	FF		Factor expressing the frequency dependence of the fatigue torque load
Temperature factor	FT		Factor taking into account the reduction in strength of flexible rubber materials at a higher temperature
Weight	$m$	kg	Weight of the coupling
Rated speed	$n_N$	rpm	Coupling speed
Maximum coupling speed	$n_{Kmax}$	rpm	Maximum permissible coupling speed
Rated power	$P_N$	kW	Rated output on the coupling, usually the output of the driven machine
Rated torque	$T_N$	Nm	Rated torque as nominal load on the coupling
Fatigue torque	$T_W$	Nm	Amplitude of the dynamic coupling load
Maximum torque	$T_{max}$	Nm	More frequently occurring maximum load, e.g. during starting
Overload torque	$T_{OL}$	Nm	Very infrequently occurring maximum load, e.g. during short circuit or blocking conditions
Rated coupling torque	$T_{KN}$	Nm	Torque which can be transmitted as static torque by the coupling over the period of use.
Maximum coupling torque	$T_{Kmax}$	Nm	Torque which can be frequently transmitted (up to 25 times an hour) as maximum torque by the coupling.
Coupling overload torque	$T_{KOL}$	Nm	Torque which can very infrequently be transmitted as maximum torque by the coupling.
Fatigue coupling torque	$T_{KW}$	Nm	Torque amplitude which can be transmitted by the coupling as dynamic torque at a frequency of 10 Hz over the period of use.
Resonance factor	$V_R$		Factor specifying the torque increase at resonance
Temperature	$T_a$	°C	Ambient temperature of the coupling in operation
Damping coefficient	$\Psi$	psi	Damping parameter

## Typical coupling solutions for different example applications

The specified application factors are recommendations; regulations, rules and practical experience take priority as assessment criteria.

No application factor need be taken into account with FLUDEX couplings.

In the case of highly flexible couplings of the ELPEX, ELPEX-S and ELPEX-B series, deviating application factors are stated in the product descriptions.

FLUDEX couplings are mostly mounted on the high-speed gear shaft.

Example applications	Application factor FB
<b>Electric motor without gear unit</b>	
Centrifugal pumps	1.0
Piston pumps	1.5
Vacuum pumps	1.5
Fans with $T_N$ less than 75 Nm	1.5
Fans with $T_N$ from 75 to 750 Nm	1.75
Fans with $T_N$ larger than 750 Nm	1.75
Blowers	1.5
Frequency converters / generators	1.25
Reciprocating compressors	1.75
Screw-type compressors	1.5
<b>Internal-combustion engine without gear unit</b>	
Generators	1.75
Pumps	1.5
Fans	1.75
Hydraulic pumps, excavators, construction machines	1.5
Compressors / screw-type compressors	1.5
Agricultural machinery	1.75
<b>Other</b>	
Turbine gear units	1.5
Hydraulic motor - gear unit	1.25
<b>Electric motor with gear unit</b>	
<b>Chemical industry</b>	
Extruders	1.5
Pumps - centrifugal pumps	1.0
Pumps - piston pumps	1.75
Pumps - plunger pumps	1.5
Reciprocating compressors	1.75
Calenders	1.5
Kneaders	1.75
Cooling drums	1.25
Mixers	1.25
Stirrers	1.25
Toasters	1.25
Drying drums	1.25
Centrifuges	1.25
Crushers	1.5
<b>Power generation and conversion</b>	
Compressed air, reciprocating compressors	1.75

Example applications	Application factor FB
Compressed air, screw-type compressors	1.25
Air - Blowers	1.5
Air - Cooling tower fans	1.5
Air - Turbine blowers	1.5
Generators, converters	1.25
Welding generators	1.25
<b>Metal production, iron and steel works</b>	
Plate tilters	1.5
Ingot pushers	1.75
Slabbing mill	1.75
Coiling machines	1.5
Roller straightening machines	1.5
Roller tables	1.75
Shears	1.75
Rollers	1.75
<b>Metal working machines</b>	
Plate bending machines	1.5
Plate straightening machines	1.5
Hammers	1.75
Planing machines	1.75
Presses, forging presses	1.75
Shears	1.5
Grinding machines	1.25
Punches	1.5
Machine tools: Main drives	1.5
Machine tools: Auxiliary drives	1.25
<b>Food industry</b>	
Filling machines	1.25
Kneading machines	1.5
Mashers	1.5
Sugar cane production	1.5
<b>Production machines</b>	
Construction machines, hydraulic pumps	1.25
Construction machines, traversing gears	1.5
Construction machines, suction pumps	1.5
Construction machines, concrete mixers	1.5
Printing machines	1.25
Woodworking - barking drums	1.5
Woodworking - planing machines	1.5

Example applications	Application factor FB
Woodworking - reciprocating saws	1.5
Grinding machines	1.5
Textile machines - winders	1.5
Textile machines - printing machines	1.5
Textile machines - tanning vats	1.5
Textile machines - shredders	1.5
Textile machines - looms	1.5
Packaging machines	1.5
Brick molding machines	1.75
<b>Transport and logistics</b>	
Passenger transport - elevators	1.5
Passenger transport - escalators	1.5
Conveyor systems - bucket elevators	1.5
Conveyor systems - hauling winches	1.5
Conveyor systems - belt conveyors	1.5
Conveyor systems - endless-chain conveyors	1.5
Conveyor systems - circular conveyors	1.5
Conveyor systems - screw conveyors	1.5
Conveyor systems - inclined hoists	1.5
Crane traversing gear	1.5
Hoisting gear	1.5
Crane lifting gear	2.0
Crane traveling gear	1.5
Crane slewing gear	1.5
Crane fly jib hoists	1.5
Cable railways	1.5
Drag lifts	1.5
Winches	1.5
<b>Cellulose and paper</b>	
Paper-making machines, all	1.5
Pulper drives	1.5
<b>Cement industry</b>	
Crushers	1.75
Rotary furnaces	1.5
Hammer mills	1.75
Ball mills	1.75
Pug mills	1.75
Mixers	1.5
Pipe mills	1.5
Beater mills	1.75
Separators	1.5
Roller presses	1.75

# SELECTION OF THE COUPLING SIZE

E

The torque load of the coupling must be determined from the output of the driven machine and the coupling speed.

Rated coupling load  $T_N = 9550 \times P_N / n_N$   
 ( $T_N$  in Nm;  $P_N$  in kW;  $n_N$  in rpm)

The rated coupling load obtained in this way must be multiplied by factors and compared with the rated coupling torque. An ideal but expensive method is to measure the torque characteristic on the coupling. For this, Flender offers special adapters fitted with torque measuring devices.

The rated coupling torque  $T_{KN}$  is the torque which can be transmitted by the coupling over an appropriate period of use if the load is applied to the coupling purely statically at room temperature.

Application factors are to express the deviation of the real coupling load from the "ideal" load condition.

## Coupling load in continuous operation

The operating principles of the driving and driven machines are divided into categories and the application factor FB derived from these in accordance with DIN 3990-1.

**Application factor for N-EUPEX, N-EUPEX-DS, RUPEX, N-BIPEX, ELPEX-B, N-ARPEX, ARPEX, ZAPEX and FLUDEX**

Application factor FB				
Torque characteristic of the driving machine	Torque characteristic of the driven machine			
	uniform	uniform with moderate shock loads	non uniform	very rough
uniform	1.0	1.25	1.5	1.75
uniform with moderate shock loads	1.25	1.5	1.75	2.0
non uniform	1.5	1.75	2.0	2.5

### Examples of torque characteristic of driving machines:

- uniform: Electric motors with soft starting, steam turbines
- uniform with moderate shock loads: Electric motors without soft starting, hydraulic motors, gas and water turbines
- non uniform: Internal-combustion engines

### Examples of torque characteristic in driven machines:

- uniform: Generators, centrifugal pumps for light fluids
- uniform with moderate shock loads: Centrifugal pumps for viscous fluids, elevators, machine tool drives, centrifuges, extruders, blowers, crane drives
- non uniform: Excavators, kneaders, conveyor systems, presses, mills
- very rough: Crushers, excavators, shredders, iron/smelting machinery

Temperature factor FT												
Coupling	Elastomer material	Low temperature °C	Temperature $T_a$ on the coupling									
			under -30 °C	-30 °C up to 50 °C	up to 60 °C	up to 70 °C	up to 80 °C	up to 90 °C	up to 100 °C	up to 110 °C	up to 120 °C	
N-EUPEX	NBR	-30	-	1.0	1.0	1.0	1.0	1.0	-	-	-	-
N-EUPEX	NR	-50	1.1 <sup>1)</sup>	1.0	-	-	-	-	-	-	-	-
N-EUPEX	HNBR	-10	-	1.0	1.0	1.0	1.0	1.0	1.25	1.25	-	-
N-EUPEX	TPU	-50	1.0	1.0	1.05	1.10	1.15	-	-	-	-	-
N-EUPEX DS	NBR	-30	-	1.0	1.0	1.0	1.0	1.0	-	-	-	-
RUPEX	NBR	-30	-	1.0	1.0	1.0	1.0	1.0	-	-	-	-
RUPEX	NR	-50	1.1	1.0	-	-	-	-	-	-	-	-
RUPEX	HNBR	-10	-	1.0	1.0	1.0	1.0	1.0	1.25	1.25	-	-
N-BIPEX	TPU	-50	1.0	1.0	1.0	1.0	1.0	1.0	1.0	1.0	1.3	1.5
ELPEX	NR	-40	1.1	1.0	1.25	1.40	1.60	-	-	-	-	-
ELPEX-B	NR	-50	1.1	1.0	-	-	-	-	-	-	-	-
ELPEX-B	CR	-15	-	1.0	1.0	1.0	1.0	-	-	-	-	-
ELPEX-S SN, NN, WN	NR	-40	1.1	1.0	1.25	1.40	1.60	-	-	-	-	-
ELPEX-S NX	VMQ	-40	1.1	1.0	1.0	1.0	1.0	1.0	1.1	1.25	1.4	1.6

- NR = natural rubber, natural-synthetic rubber mixture
- NBR = nitril-butadiene-rubber (Perbunan)
- HNBR = hydrated acrylonitrile butadiene rubber
- CR = chloroprene rubber (FRAS fire-resistant and anti-static)
- VMQ = silicone
- TPU = polyurethane

<sup>1)</sup> The N-EUPEX coupling is not suitable for shock loads when used at low temperatures.

Coupling size  $T_{KN} \geq T_N \cdot FB \cdot FT$

In the case of ARPEX and ZAPEX coupling types, no temperature factor (FT = 1.0) need be taken into account.

### Coupling load at maximum and overload conditions

The maximum torque is the highest load acting on the coupling in normal operation. Maximum torques at a frequency of up to 25 times an hour are permitted and must be lower than the maximum coupling torque. Examples of maximum torque conditions are: Starting operations, stopping operations or usual operating conditions with maximum load.

$$T_{Kmax} \geq T_{Max} \cdot FT$$

Overload torques are maximum loads which occur only in combination with special, infrequent operating conditions. Examples of overload torque conditions are: Motor short circuit, emergency stop or blocking because of component breakage. Overload torques at a frequency of once a month are permitted and must be lower than the maximum overload torque of the coupling. The overload condition may last only a short while, i.e. fractions of a second.

$$T_{KOL} \geq T_{OL} \cdot FT$$

### Coupling load due to dynamic torque load

Applying the frequency factor FF, the dynamic torque load must be lower than the coupling fatigue torque.

Dynamic torque load

$$T_{KW} \geq T_W \cdot FF$$

Frequency of the dynamic torque load  $f_{err} \leq 10$  Hz frequency factor FF = 1.0

Frequency of the dynamic torque load  $f_{err} > 10$  Hz frequency factor FF =  $\sqrt{(f_{err}/10 \text{ Hz})}$

**For the ZAPEX and ARPEX series, the frequency factor is always FF = 1.0.**

# SELECTION OF THE COUPLING SIZE

E

## Checking the maximum speed

For all load situations  $n_{K_{max}} \geq n_{max}$

## Checking permitted shaft misalignment

For all load situations, the actual shaft misalignment must be less than the permitted shaft misalignment.

## Checking bore diameter, mounting geometry and coupling design

The check must be made on the basis of the dimension tables. The maximum bore diameter applies to parallel keyways to DIN 6885. For other keyway geometries, the maximum bore diameter can be reduced.

On request, couplings with adapted geometry can be provided.

## Coupling behavior under overload conditions

The ZAPEX, N-ARPEX, ARPEX, N-EUPEX, RUPEX and N-BIPEX coupling series can withstand overloads until the breakage of metal parts. These coupling series are designated as fail-safe.

The N-EUPEX DS, ELPEX-B, ELPEX-S and ELPEX coupling series throw overload. The elastomer element of these couplings is irreparably damaged without damage to metal parts when subjected to excessive overload.

These coupling series are designated as non-fail-safe. These types that fail can be fitted with a so-called fail-safe device. This additional component enables emergency operation, even after the rubber element of the coupling has been irreparably damaged.

## Checking shaft-hub connection

The torques specified in the tables of power ratings data of the coupling series do not necessarily apply to the shaft-hub connection. Depending on the shaft-hub connection, proof of form stability is required. Flender recommends obtaining proof of form strength by using calculation methods in accordance with the current state of the art.

Fitting recommendations for the shaft-hub connection are given in the **Appendix**.

Shaft-hub connection	Suggestion for calculation method
Keyway connection to DIN 6885-1	DIN 6892
Shrink fit	DIN 7190
Spline to DIN 5480	
Bolted flange connection	VDI 2230
Flange connection with close-fitting bolts	

The coupling hub is frequently fitted flush with the shaft end face. If the shaft projects, the risk of collision with other coupling parts must be checked. If the shaft is set back, in addition to the load-bearing capacity of the shaft-hub connection, the correct positioning of the hub must be ensured as well. If the bearing hub length is insufficient, restorative forces may cause tilting movements and so wear to and impairment of the axial retention. Also, the position of the set screw to be positioned on sufficient shaft or parallel key material must be noted.

## Checking low temperature and chemically aggressive environment

The minimum permitted coupling temperature is specified in the Temperature factor FT table. In the case of chemically aggressive environments, please consult the manufacturer.



# FEATURES OF THE STANDARD TYPE

Couplings	Features of the standard type
All coupling series except ARPEX clamping hubs and FLUDEX with keyway to ASME B17.1	Bore tolerance H7
N-ARPEX and ARPEX clamping hubs	Bore tolerance G6 (suitable for shaft tolerance h6)
FLUDEX couplings with keyway to ASME B17.1	Hollow shafts: bore tolerance K7 other parts: bore tolerance M7
All coupling series with bore diameter - imperial	Parallel keyway to ASME B17.1
Bore diameter metric in the case of ZAPEX, N-ARPEX and ARPEX coupling series as well as coupling hubs with applied brake disks or brake drums of the N-EUPEX and RUPEX series	Parallel keyway to DIN 6885-1 keyway width P9
Bore diameter metric in the case of the N-EUPEX, RUPEX, N-BIPEX, ELPEX-S, ELPEX-B, ELPEX, FLUDEX coupling series	Parallel keyway to DIN 6885-1 keyway width JS9
All coupling series except FLUDEX	Axial locking by means of set screw
FLUDEX coupling series	Axial lock by means of set screw or end washer
All coupling series	Balancing in accordance with half parallel key standard
ZAPEX, N-ARPEX, ARPEX, N-EUPEX, RUPEX, N-BIPEX, ELPEX-S, ELPEX-B and ELPEX coupling series	Balancing quality G16
FLUDEX coupling series	Balancing quality G6.3
SIPEX and BIPEX-S coupling series	Balancing quality G6.3 for 3600 rpm
All series	Unpainted
All series	Preservation with cleaning emulsion
FLUDEX couplings	Fuse 140 °C

## Configurator

The article number can be obtained with the help of the Configurator. The coupling can be selected in a product configurator and specified using selection menus.

The coupling can be selected via "Technical selection" (technical selection) or via "Direct selection" (via article no.).

The Configurator is available under [flender.com](https://www.flender.com).

# GENERAL

## Technical specifications, N-EUPEX DS series

Power ratings of the N-EUPEX DS series							
Size	Rated torque	Maximum torque	Torsional stiffness at 50 % capacity utilization <sup>1)</sup>	Assembly	Permitted shaft misalignment at speed <sup>3)</sup> $n = 1500$ rpm		
	$T_{KN}$ Nm	$T_{Kmax}$ Nm	$C_{Tdyn}$ kNm/rad	Gap dimension <sup>2)</sup> $\Delta S$ mm	Radial $\Delta K_r$ mm	Angle $\Delta K_w$ °	
66	19	38	0.73	1.0	0.2	0.15	
76	34	68	1.36	1.0	0.2	0.15	
88	60	120	2.62	1.0	0.2	0.12	
103	100	200	4.00	1.0	0.2	0.12	
118	160	320	6.30	1.0	0.2	0.10	
135	240	480	10.5	1.0	0.25	0.10	
152	360	720	13.6	1.0	0.25	0.10	
172	560	1120	27.2	2.0	0.3	0.10	
194	880	1760	47.0	2.0	0.3	0.10	
218	1340	2680	70.0	2.0	0.3	0.09	
245	2000	4000	106	2.0	0.35	0.09	
272	2800	5600	149	2.5	0.35	0.08	
305	3900	7800	214	2.5	0.4	0.08	
340	5500	11000	350	2.5	0.4	0.08	
380	7700	15400	480	2.5	0.5	0.08	
430	10300	20600	730	2.5	0.5	0.08	
472	13500	27000	990	2.5	0.6	0.08	
514	16600	33200	1270	2.5	0.6	0.07	
556	21200	42400	1540	2.5	0.65	0.07	

For coupling fatigue torque:  
 $T_{KW} = 0,15 \cdot T_{KN}$ , where  $T_N > T_W$  must be adhered to.

### Note

For fitting, the maximum gap dimension of  
 $S_{max.} = S + \Delta S$  and the minimum gap dimension of  
 $S_{min.} = S - \Delta S$  are permitted.

<sup>1)</sup> The correction factors for torsion spring stiffness and permitted shaft misalignment correspond to the specifications for the puncture-proof types [page 7/9](#)

<sup>2)</sup> Does not apply to type HDS.

<sup>3)</sup> The maximum speed for the respective type must be noted.  
 For additional information on the allowable shaft misalignment, please refer to the operating instructions.

# TYPE ADS

for easy elastomer flexible replacement

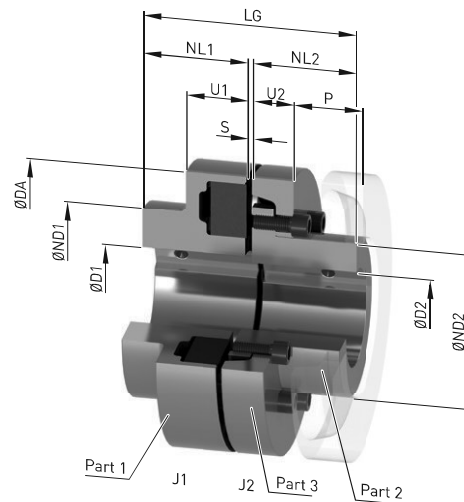

Size	Rated torque $T_{KN}$ Nm	Speed $n_{Kmax}$ rpm	Dimensions in mm													Mass moment of inertia $J_1/J_2$ kgm <sup>2</sup>	Article no. <sup>1)</sup>	Weight $m$ kg
			Bore with keyway to DIN 6885-1		DA	ND1	ND2	NL1/NL2	S	U1	U2	P	LG					
			D1	D2														
min.	max.	min.	max.															
118	160	5300	-	50	-	45	118	86	60.5	40	3	34	20	33	83	0.003	2LC0110-4AB	2.8
135	240	5100	-	60	-	55	135	100	73.5	50	3	36	23	38	103	0.005	2LC0110-5AB	4.3
152	360	4900	-	65	-	60	152	108	80.5	55	3	36	28	43	113	0.008	2LC0110-6AB	5.9
172	560	4250	-	70	-	70	172	118	93.5	60	4	41	28	47	124	0.014	2LC0110-7AB	8.2
194	880	3800	-	80	-	80	194	135	106	70	4	44	30	50	144	0.025	2LC0110-8AB	12
218	1340	3400	-	85	-	90	218	150	119	80	4	47	32	53	164	0.05	2LC0111-0AB	17
245	2000	3000	-	90	-	100	245	150	135	90	4	52	38	61	184	0.08	2LC0111-1AB	23
272	2800	2750	46	100	-	115	272	165	153	100	5.5	60	42	69	205.5	0.14	2LC0111-2AB	32
305	3900	2450	49	110	54	125	305	180	168	110	5.5	65	42	73	225.5	0.22	2LC0111-3AB	43
340	5500	2150	49	120	45	145	340	200	196	125	5.5	70	47	78	255.5	0.39	2LC0111-4AB	61
380	7700	2000	61	140	60	165	380	230	226	140	5.5	74	51	83	285.5	0.69	2LC0111-5AB	86
430	10300	1700	66	150	65	180	430	250	246	160	5.5	78	56	88	325.5	1.2	2LC0111-6AB	120
472	13500	1550	80	160	80	190	472	265	261	180	7.5	86	64	99	367.5	1.9	2LC0111-7AB	161
514	16600	1400	90	180	90	215	514	300	296	190	7.5	90	65	104	387.5	2.9	2LC0111-8AB	206
556	21200	1300	100	190	100	225	556	315	310	210	7.5	102	68	115	427.5	4.1	2LC0112-0AB	256

### Configurable variants <sup>1)</sup>

- ØD1 Without finished bore  
With finished bore
- ØD2 Without finished bore  
With finished bore

### Notes

- Weights and mass moments of inertia apply to maximum bores.

### Ordering example

- N-EUPEX ADS coupling, size 135
- Part 1: Bore D1 42H7 mm, keyway to DIN 6885-1 and set screw
- Part 2: Bore D2 32H7 mm, keyway to DIN 6885-1 and set screw

Article no.: 2LC0110-5AB99-0AA0 L0X+M0T

<sup>1)</sup> To identify complete item numbers specifying the available finish boring options and – if necessary – further order options, please use our configurators on [flender.com](http://flender.com).

↗ For online configuration on [flender.com](http://flender.com), click on the item no.

# TYPE BDS

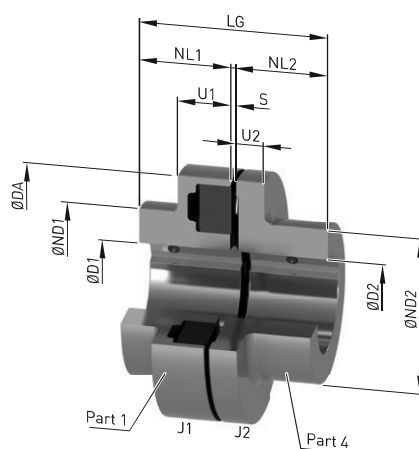

Size	Rated torque $T_{KN}$ Nm	Speed $n_{Kmax}$ rpm	Dimensions in mm											Mass moment of inertia $J_1/J_2$ kgm <sup>2</sup>	Article no. <sup>1)</sup>	Weight $m$ kg	
			Bore with keyway to DIN 6885-1				DA	ND1	ND2	NL1/ NL2	S	U1	U2				LG
			D1 min.	D1 max.	D2 min.	D2 max.											
66	19	7500	-	20	-	25	66	66	40	20	3	20	8	43	0.0001	2LC0110-0AA	0.46
76	34	7000	-	28	-	30	76	76	50	20	3	20	8	43	0.0002	2LC0110-1AA	0.64
88	60	6000	-	35	-	42	88	88	68	30	3	30	10	63	0.0008	2LC0110-2AA	1.4
103	100	5500	-	45	-	48	103	76	76	35	3	30	12	73	0.0015	2LC0110-3AA	2.1
118	160	5300	-	50	-	55	118	86	86	40	3	34	14	83	0.003	2LC0110-4AA	3.0
135	240	5100	-	60	-	60	135	100	100	50	3	36	18	103	0.006	2LC0110-5AA	5.1
152	360	4900	-	65	-	65	152	108	100	55	3	36	20	113	0.009	2LC0110-6AA	6.4
172	560	4250	-	70	-	70	172	118	108	60	4	41	20	124	0.016	2LC0110-7AA	8.7
194	880	3800	-	80	-	80	194	135	125	70	4	44	20	144	0.028	2LC0110-8AA	13
218	1340	3400	-	85	-	85	218	150	140	80	4	47	24	164	0.052	2LC0111-0AA	19
245	2000	3000	-	90	-	90	245	150	150	90	4	52	18	184	0.078	2LC0111-1AA	24
272	2800	2750	46	100	46	100	272	165	165	100	5.5	60	18	205.5	0.13	2LC0111-2AA	32
305	3900	2450	49	110	54	110	305	180	180	110	5.5	65	20	225.5	0.21	2LC0111-3AA	43

## Configurable variants <sup>1)</sup>

- ØD1 Without finished bore  
With finished bore
- ØD2 Without finished bore  
With finished bore

## Notes

- Weights and mass moments of inertia apply to maximum bores.

## Ordering example

- N-EUPEX BDS coupling, size 103
- Part 1: Bore D1 42H7 mm, keyway to DIN 6885-1 and set screw
- Part 4: Bore D2 32H7 mm, keyway to DIN 6885-1 and set screw

Article no.: 2LC0110-3AA99-0AA0 L0X+M0T

<sup>1)</sup> To identify complete item numbers specifying the available finish boring options and – if necessary – further order options, please use our configurators on [flender.com](https://www.flender.com).

➤ For online configuration on [flender.com](https://www.flender.com), click on the item no.

# TYPE HDS

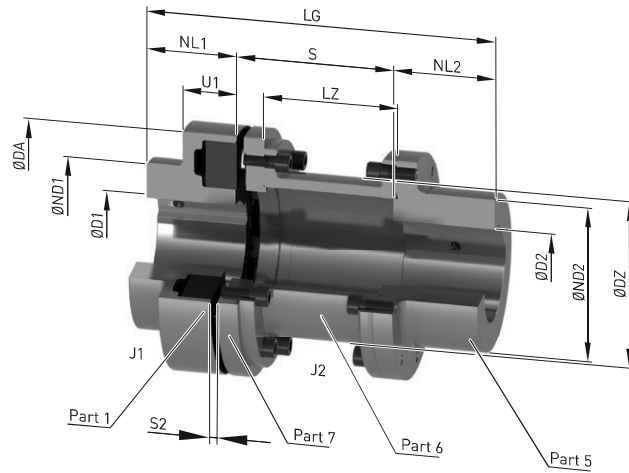

Size	Rated torque $T_{KN}$ Nm	Speed $n_{Kmax}$ rpm	Dimensions in mm Bore with keyway to DIN 6885-1													Mass moment of inertia		Article no. <sup>1)</sup>	Weight $m$ kg	
			D1		D2		DA	ND1	ND2	NL1	NL2	S	S2	LZ	DZ	LG	$J_1$ kgm <sup>2</sup>			$J_2$ kgm <sup>2</sup>
			min.	max.	min.	max.														
88	60	6000	-	35	-	38 <sup>2)</sup>	88	88	55	30	45	100	5	87	51	175	0.0007	0.0014	2LC0110-2AC	2.6
												140		127		215		0.0015		2LC0110-2AC
103	100	5500	-	45	-	48 <sup>2)</sup>	103	76	70	35	45	100	5	87	63	180	0.001	0.0029	2LC0110-3AC	3.8
												140		127		220		0.0032		2LC0110-3AC
118	160	5300	-	50	-	55 <sup>2)</sup>	118	86	80	40	50	100	85	190	190	0.003	0.0059	2LC0110-4AC	4.9	
											60		180		165		280		0.0066	2LC0110-4AC
											50	100	85	200	0.01	2LC0110-5AC	7.3			
											50	140	125	240	0.01	2LC0110-5AC	7.8			
135	240	5100	-	60	-	60 <sup>2)</sup>	135	100	90	50	60	180	5	165	85	290	0.006	0.012	2LC0110-5AC	8.2
											70		200	185		320		0.012		2LC0110-5AC
											80	250	235	380	0.013	2LC0110-5AC	9.0			
											65	100	82	220	0.02	2LC0110-6AC	10.8			
152	360	4900	-	65	-	65 <sup>2)</sup>	152	108	100	55	65	140	122	260	260	0.011	0.02	2LC0110-6AC	11.3	
											65		180		5		162		91	300
											65	200	182	320	0.023	2LC0110-6AC	12.1			
											80	250	232	385	0.024	2LC0110-6AC	12.6			

### Configurable variants <sup>1)</sup>

- ØD1 Without finished bore  
With finished bore
- ØD2 Without finished bore  
With finished bore

<sup>1)</sup> To identify complete item numbers specifying the available finish boring options and – if necessary – further order options, please use our configurators on [flender.com](http://flender.com).

<sup>2)</sup> For bore diameters greater than the following values, the feather key must be at least 3 mm behind the shaft end. Size 88 D2 > 32 mm; size 103 D2 > 42 mm; size 118 D2 > 50 mm; size 135 D2 > 59 mm; size 152 D2 > 64 mm.

↗ For online configuration on [flender.com](http://flender.com), click on the item no.

Size	Rated torque $T_{KN}$ Nm	Speed $n_{Kmax}$ rpm	Dimensions in mm													Mass moment of inertia		Article no. <sup>1)</sup>	Weight $m$ kg					
			Bore with keyway to DIN 6885-1				DA	ND1	ND2	NL1	NL2	S	S2	LZ	DZ	LG	$J_1$ kgm <sup>2</sup>			$J_2$ kgm <sup>2</sup>				
D1	D2		D3		D4													D5			D6		D7	
min.	max.	min.	max.	min.	max.	min.	max.	min.	max.	min.	max.	min.	max.	min.	max.	min.	max.							
172	560	4250	-	70	-	70	172	118	108	60								70	100	81.5	230	0.03	2LC0110-7AC	13.8
																		70	140	121.5	270	0.034	2LC0110-7AC	14.5
																		70	180	161.5	310	0.037	2LC0110-7AC	15.4
																		70	200	181.5	330	0.037	2LC0110-7AC	15.7
																		80	250	231.5	390	0.039	2LC0110-7AC	16.7
194	880	3800	-	80	-	80	194	135	125	70	80							140	121.5	290	0.057	2LC0110-8AC	20	
																		180	161.5	330	0.061	2LC0110-8AC	21	
																		200	181.5	350	0.063	2LC0110-8AC	22	
																		250	231.5	400	0.068	2LC0110-8AC	23	
																		140	118.5	310	0.10	2LC0111-0AC	30	
218	1340	3400	-	85	-	90	218	150	140	80	90							180	158.5	350	0.062	2LC0111-0AC	31	
																		200	178.5	370	0.11	2LC0111-0AC	32	
																		250	228.5	420	0.12	2LC0111-0AC	33	
																		140	118.5	330	0.16	2LC0111-1AC	34	
																		180	158.5	370	0.17	2LC0111-1AC	35	
245	2000	3000	-	90	-	100	245	150	150	90	100							200	178.5	390	0.09	2LC0111-1AC	36	
																		250	228.5	440	0.18	2LC0111-1AC	38	
																		180	152.5	390	0.3	2LC0111-2AC	51	
																		200	172.5	410	0.16	2LC0111-2AC	52	
																		250	222.5	460	0.33	2LC0111-2AC	55	
305	3900	2450	49	110	51	130	305	180	180	110	120	250	8	222.5	215	480	0.28	0.51	2LC0111-3AC	71				
340	5500	2150	49	120	51	140	340	200	200	125	140	250	8	222.5	246	515	0.50	0.85	2LC0111-4AC	101				
380	7700	2000	61	140	51	160	380	230	230	140	150	250	8	220.5	272	540	0.80	1.4	2LC0111-5AC	125				
430	10300	1700	66	150	51	180	430	250	250	160	180	250	8	185.5	311	590	1.4	2.4	2LC0111-6AC	195				
472	13500	1550	80	160	51	190	472	265	265	180	180	250	10	182	354	610	2.1	4.0	2LC0111-7AC	224				

### Configurable variants <sup>1)</sup>

- ØD1 Without finished bore  
With finished bore
- ØD2 Without finished bore  
With finished bore

### Notes

- For dimension U1, see type ADS on page 7/32 and type BDS on page 7/33.
- During assembly, the gap dimension S2 must not exceed the permissible tolerance of +1 mm.
- For sizes 305 to 472 the outer diameter of part 5 and part 7 is smaller than ØDA.
- Weights and mass moments of inertia apply to maximum bores.

### Ordering example

- N-EUPEX HDS coupling, size 103, S = 100 mm
- Part 1: Bore D1 42H7 mm, keyway to DIN 6885-1 and set screw
- Part 5: Bore D2 32H7 mm, keyway to DIN 6885-1 and set screw
- Coupling micro-balanced G6.3 at 1500 rpm in accordance with half parallel key standard

Article no.: 2LC0110-3AC99-0AA0-Z L0X+M0T+W02+Y95  
Plain text to Y95: G=6.3;n=1500rpm

<sup>1)</sup> To identify complete item numbers specifying the available finish boring options and – if necessary – further order options, please use our configurators on [flender.com](https://www.flender.com).

↗ For online configuration on [flender.com](https://www.flender.com), click on the item no.

# SPARE AND WEAR PARTS

## Elastomer flexibles of the N-EUPEX series

NBR elastomer flexibles 80 ShoreA standard type			
Size	Article No. (flexible set for one coupling)	Number of flexibles per set	Weight per set kg
58	2LC0170-0WA00-0AA0	4	0.012
68	2LC0170-1WA00-0AA0	5	0.015
80	2LC0170-2WA00-0AA0	6	0.02
95	2LC0170-3WA00-0AA0	6	0.03
110	2LC0170-4WA00-0AA0	6	0.045
125	2LC0170-5WA00-0AA0	6	0.06
140	2LC0170-6WA00-0AA0	6	0.09
160	2LC0170-7WA00-0AA0	7	0.12
180	2LC0170-8WA00-0AA0	8	0.17
200	2LC0171-0WA00-0AA0	8	0.23
225	2LC0171-1WA00-0AA0	8	0.3
250	2LC0171-2WA00-0AA0	8	0.38
280	2LC0171-3WA00-0AA0	8	0.55
315	2LC0171-4WA00-0AA0	9	0.7
350	2LC0171-5WA00-0AA0	9	0.85
400	2LC0171-6WA00-0AA0	10	1.2
440	2LC0171-7WA00-0AA0	10	1.5
480	2LC0171-8WA00-0AA0	10	2.1
520	2LC0172-0WA00-0AA0	10	2.6
560	2LC0172-1WA00-0AA0	10	3.6
610	2LC0172-2WA00-0AA0	10	4.9
660	2LC0172-3WA00-0AA0	10	6.3
710	2LC0172-4WA00-0AA0	10	7.6

HP elastomer flexibles for type DK/DKS (two-joint)			
Size	Article No. (flexible set for one coupling)	Number of flexibles per set	Weight per set kg
68	2LC0170-1VD00-0AA0	10	0.03
80	2LC0170-2VD00-0AA0	12	0.04
95	2LC0170-3VD00-0AA0	12	0.06
110	2LC0170-4VD00-0AA0	12	0.09
125	2LC0170-5VD00-0AA0	12	0.12
140	2LC0170-6VD00-0AA0	12	0.18
160	2LC0170-7VD00-0AA0	14	0.24
180	2LC0170-8VD00-0AA0	16	0.34
200	2LC0171-0VD00-0AA0	16	0.46
225	2LC0171-1VD00-0AA0	16	0.6
250	2LC0171-2VD00-0AA0	16	0.8
280	2LC0171-3VD00-0AA0	16	1.1

### Notes

- The elastomer flexibles are wear parts. The service life depends on the operating conditions.

## Elastomer flexibles of the N-EUPEX DS series

NBR elastomer flexibles standard type			
Size	Article No. (flexible set for one coupling)	Number of flexibles per set	Weight per set kg
66	2LC0110-0WA00-0AA0	4	0.012
76	2LC0110-1WA00-0AA0	5	0.015
88	2LC0110-2WA00-0AA0	6	0.021
103	2LC0110-3WA00-0AA0	6	0.033
118	2LC0110-4WA00-0AA0	6	0.048
135	2LC0110-5WA00-0AA0	6	0.072
152	2LC0110-6WA00-0AA0	6	0.1
172	2LC0110-7WA00-0AA0	7	0.16
194	2LC0110-8WA00-0AA0	8	0.21
218	2LC0111-0WA00-0AA0	8	0.28
245	2LC0111-1WA00-0AA0	8	0.45
272	2LC0111-2WA00-0AA0	8	0.64
305	2LC0111-3WA00-0AA0	8	0.72
340	2LC0111-4WA00-0AA0	9	0.92
380	2LC0111-5WA00-0AA0	9	1.2
430	2LC0111-6WA00-0AA0	10	1.6
472	2LC0111-7WA00-0AA0	10	2.0
514	2LC0111-8WA00-0AA0	10	2.5
556	2LC0112-0WA00-0AA0	10	3.2

## Notes

- The elastomer flexibles are wear parts. The service life depends on the operating conditions.

## Friction linings of the N-EUPEX type ERN

Friction linings, standard version			
Size	Article No. (set for one coupling)	Number of friction linings per set	Weight per set kg
80	2LC0170-2VK00-0AA0	2	0.05
95	2LC0170-3VK00-0AA0	2	0.06
110	2LC0170-4VK00-0AA0	2	0.06
125	2LC0170-5VK00-0AA0	2	0.10
140	2LC0170-6VK00-0AA0	2	0.12
160	2LC0170-7VK00-0AA0	2	0.12
180	2LC0170-8VK00-0AA0	2	0.23
200	2LC0171-0VK00-0AA0	2	0.34
225	2LC0171-1VK00-0AA0	2	0.34
250	2LC0171-2VK00-0AA0	2	0.60
280	2LC0171-3VK00-0AA0	2	0.66

## Notes

- The friction linings are wear parts. The service life depends on the operating conditions.