

# 11.5 Type SC – Servo worm gearboxes

## 11.5.1 General construction

The SC AdServo gearboxes are based on the proven worm gearboxes of the S-type series. In worm gearboxes, both shafts intersect in a defined distance (A). This centre-to-centre distance is reflected in the specification of the gearbox size. (Example: S 100 – centre-to-centre distance 100 mm)

## 11.5.2 Tothing

A gear set consists of worm shaft and worm gear.

The worm shaft made of carburised steel is hardened, the tothing is ground. The worm gear consists of a high-quality bronze alloy, the tothing is milled.

## 11.5.3 Models

Due to the modular system, different gearbox Models can be configured. The variants differ in the type of the shafts, the rotational direction of the shafts, and the support by bearings.

## 11.5.4 Threaded mounting holes

All sides of the gearboxes are machined. The housing surface on the side 1 and the flange surfaces on the sides 5 and 6 may be used as mounting surfaces. All flanges always have threaded mounting holes.

You have the following available ordering options:

Gearbox size	Ordering options	Threaded mounting holes are in the <u>housing surfaces</u> on the gearbox side	Threaded mounting holes are in the <u>flanges</u> on the gearbox side
040-100	1	1	5, 6
040-100	2	1, 2	5, 6
040-100	3	1, 3	5, 6
040-100	4	1, 4	5, 6
040-100	5	1, 5	5, 6
040-100	6	1, 6	5, 6

Table 11.5.4-1

The standard version has the order code 2.  
Order code example: SC 050 5:1 B0 -1.2-600/0000  
Please enquire other mounting options.

## 11.5.5 Installation position

The installation position is defined by the gearbox side directed downwards during operation and will be indicated by the corresponding numeral. The following is an order code example with the numeral 2. Order code example: SC 050 5:1 B0 -1.2-600/0000

Principally, the gearboxes can be used in all installation positions. The technically most favourable and thus recommended installation position is the installation position 1, in which the worm shaft is horizontal and located at the bottom.

For an optimal technical design of the gearboxes, we always ask to specify the installation position.

The performance data and torques listed in the selection tables are only valid if the gearboxes are used in the installation positions 1, 5 or 6. The values must be reduced by 10%, if the worm shaft is vertical or located at the top (installation position 3, 4 or 2).

## 11.5.6 Shaft designation – allocation to the gearbox sides

The worm shaft is the fast-rotating shaft.

It has the speed  $n_1$  and is identified by  $N_1$ .

The slowly rotating shaft has the speed  $n_2$  and is identified by  $N_2$ .

The worm gear is located on this shaft.

The gearbox sides are identified by the numerals 1 to 6.

For the allocation to the gearbox sides, please refer to the following figure and the Figure 4.3.1-1 Gearbox sides.

## 11.5.7 Rotational direction and gear ratio

As standard, the worm gearboxes are delivered with right-handed worm gear sets.

This results in the rotational directions according to Figure 11.5.6-1. In the special design, delivery with left-handed gear teeth is also possible. Please enquire this.

For the possible gear ratios, please refer to the performance tables. Principally, the actual gear ratio  $I_{ist}$  must be taken into account for the layout. In some cases, this deviates from the nominal gear ratio  $i$ .

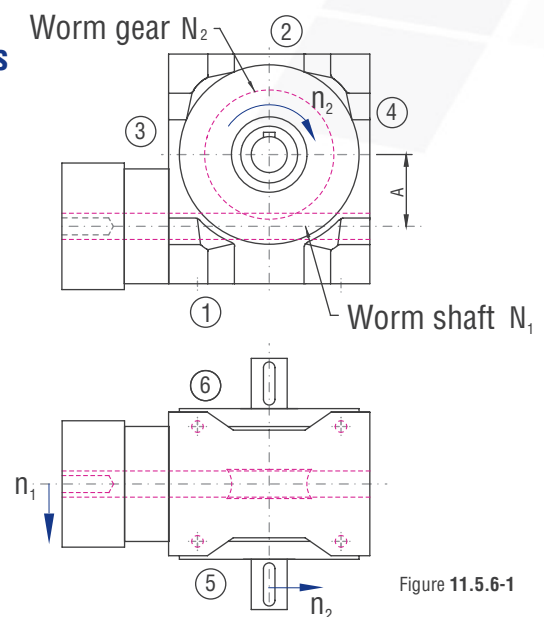

Figure 11.5.6-1

## 11.5.8 Efficiency

The achievable efficiency depends on rotational speed, torque, installation position, sealing, and lubricant type.

### Starting efficiency

The efficiency is always lower during the starting phase and in the cold operating state of the worm gearbox since the lubricating film is not formed until the sliding motion has started. Therefore a higher torque is needed. The starting efficiencies listed below are guidance values and valid for run-in gearboxes. These starting efficiencies must be taken into account for the layout.

Number of threads	Gear ratio range	Starting efficiency	Lead angle
2	26 – 15	0.56 – 0.65	10° – 12°
4	13 – 7.5	0.68 – 0.75	19° – 23°
6	5	0.74 – 0.82	28° – 32°

Table 11.5.8-1

### Operating efficiency

The tooth flanks of worm gearboxes in the as-delivered condition are not yet fully smoothed. This influence is even increased with high gear ratios. Therefore the gearboxes should be run in with approx. 50% of the nominal data, if possible, before they are operated under load. The efficiencies specified in the performance tables relate to the permissible nominal data and are guidance values for run-in gearboxes with standard sealing that have operating temperature.

## 11.5.9 Lubrication

Different conditions for the lubrication of the toothing and the roller bearings will arise depending on gearbox size, installation position, rotational speed and on-period. In order to ensure these optimally, different oil quantities and viscosities are used. These will be defined by ATEK based on your ordering details (rotational speed, on-period, and ambient temperature). They will be reflected in the abbreviation code of the type designation.

Example: SC 125 10:1 C0 -9.1- 200/A1

/A1 means:

	Abbreviation	Explanation	Reference
<b>Letter</b>	A	Oil viscosity 460	Table 11.5.9-1
<b>Numeral</b>	1	with venting	Table 11.5.9-2

The ATEK worm gearboxes are factory-filled with synthetic polyglycol oil and are normally maintenance-free. Oil viscosity and venting option are dependent on the rotational speed

Operating mode: cyclic operation S1

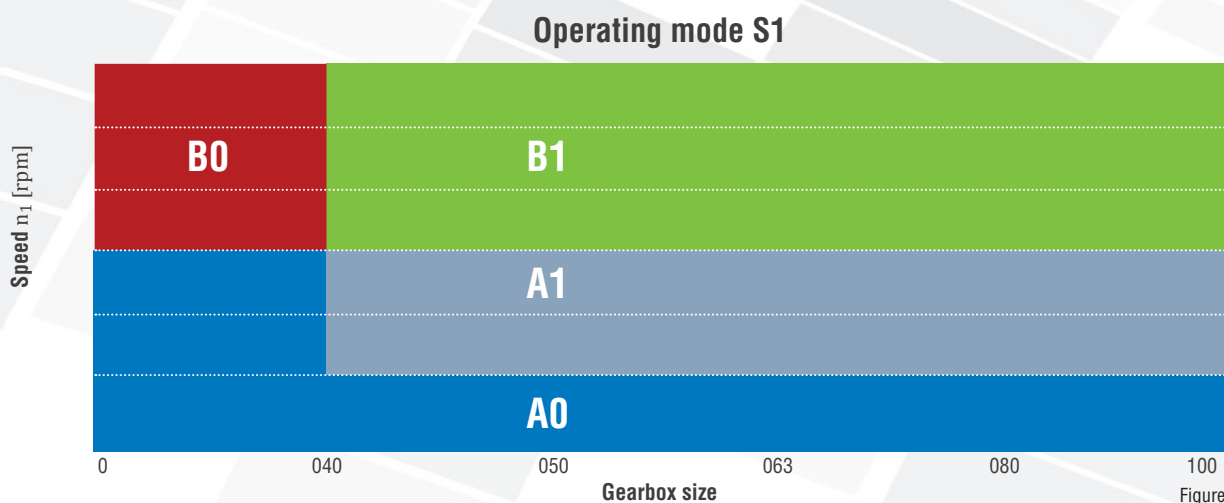

Figure 11.5.9-1

# 11.5 Type SC – Servo worm gearboxes

For the meaning of the abbreviations A through E and 0, 1, please refer to the following tables.  
Oil viscosity table

Letter	Viscosity
A	460
B	220
C	not available
D	Injection lubrication
F	Fluid grease

Table 11.5.9-1

Injection lubrication may be necessary in case of high rotational speeds and large gearboxes. In case of very low rotational speeds, lubrication by fluid grease is also possible. At operating temperatures over 50°C, high pressure will develop through air expansion in the gearbox. Then a permanent pressure compensation must be ensured. To this end, the use of a vent filter is prescribed.

Numeral	Vent filter
0	No
1	Yes

Table 11.5.9-2

## 11.5.10 Vent filter

If venting is required the gearboxes will be delivered with a vent filter. The vent bores will be equipped with screw plugs for transport. The vent filter will be enclosed as a separate item and must be mounted in the intended position prior to commissioning. An elbow may be required. The position will be specified in the order documents. Please refer to the table below for the position of the filter. Here, E4, for example, means: Venting on side 4.

### Installation position

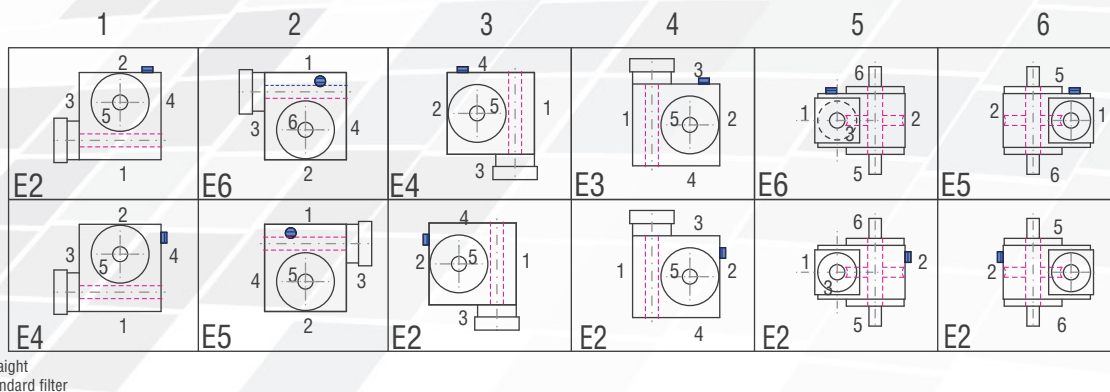

Figure 11.5.10-1

## 11.5.11 Low-backlash construction

For optimal running, the tooth space in the gear set is manufactured larger than the tooth. When the direction of rotation is changed, this results in a rotation angle until the counter-rotating tooth flanks contact each other. This rotation angle is called circumferential backlash.

### Circumferential backlash, measuring method

The circumferential backlash is measured after the drive shaft ( $N_1$ ) has been fixed. A force of around 2% of the nominal torque is applied to the output shaft ( $N_2$ ) in both rotational directions. A tooth backlash will result between the two final positions. This can be measured as rotation angle and is indicated in minutes of arc [arcmin].

### Circumferential backlash, type

All ATEK worm gearboxes can be delivered as low-backlash types. The following values can be set with standard gear sets for the different gearbox sizes:

Ordering option	Gear set	040 – 125
/O000	Standard	$\leq 30$ arcmin
/S2	Standard	$\leq 10$ arcmin
/S1	Standard	$\leq 6$ arcmin
/S0	Special gear set	$\leq 3-6$ arcmin

Table 11.5.11-1

Abbreviation: u.r. – upon request

## 11.5.12 Connection of drive shaft to coupling

For torque transmission, a zero-play coupling is located on the drive shaft.

## 11.5.13 Coupling

Two congruent coupling halves are positively connected by means of a plastic toothed ring under pretensioning. In case of extreme peak tensions and impact loads (emergency shut-off), a damping action is achieved through a slight distortion in the elastic range. The coupling is axially insertable and compensates angle errors as well as misalignments in the radial and axial direction. A later changeover to another motor is easily possible. The motor-side coupling hub is available in the following variants:

KN	KNN	SN
Clamping hub	Clamping hub with groove	Tension ring hub
For motor shafts without parallel key	For motor shafts with parallel key	For motor shafts without parallel key

Depending on the variant KN or KNN/SN, different torques can be transmitted.

### Design of the coupling

Due to the dynamic characteristics of the servo-motors, the permissible acceleration torque and the emergency-stop torque must be considered when designing the servo gearboxes. The correct coupling hub can be selected by means of the table below on the basis of the maximum permissible torques on the motor shaft, acceleration torques ( $T_{1B}$ ) and emergency-stop torques ( $T_{1Not}$ ).

Coupling Size	Hub	Coupling torques allowed [Nm]	Motor shaft diameter [mm]											
			9	11	14	16	19	24	28	32	38	42	45	
K14	KN	$T_{1B}$ [Nm]	5.3	5.6	6.1	6.5								
		$T_{1Not}$ [Nm]	7	9	13	15								
	KNN/SN	$T_{1B}$ [Nm]	10	10	10	10								
		$T_{1Not}$ [Nm]	22	25	25	25								
K19	KN	$T_{1B}$ [Nm]	17	17	17	17	17	17						
		$T_{1Not}$ [Nm]	30	30	32	32	34	34						
	KNN/SN	$T_{1B}$ [Nm]		17	17	17	17							
		$T_{1Not}$ [Nm]		30	32	34	34							
K24	KN	$T_{1B}$ [Nm]		35	36	39	39	43	46					
		$T_{1Not}$ [Nm]		45	45	50	60	65	70					
	KNN/SN	$T_{1B}$ [Nm]		48	48	48	48	48	48					
		$T_{1Not}$ [Nm]			80	100	120	120	120					
K28	KN	$T_{1B}$ [Nm]			80	81	85	91	97	102	109			
		$T_{1Not}$ [Nm]			80	100	130	140	148	156	167			
	KNN/SN	$T_{1B}$ [Nm]				128	128	128	128	128	128			
		$T_{1Not}$ [Nm]				140	240	240	240	240	240			
K38	KN	$T_{1B}$ [Nm]				94	98	104	109	113	122	126	130	
		$T_{1Not}$ [Nm]				120	125	130	136	142	152	158	164	
	KNN/SN	$T_{1B}$ [Nm]						260	260	260	260	260	260	
		$T_{1Not}$ [Nm]							500	500	500	500	500	

Table 11.5.13-1

## 11.5.14 Motor mounting

The servo-motor will be bolted to the motor flange of the gearbox on side 3. The flange number of the motor flange for the respective gearbox size is to be determined in Table 11.5.14-1.

### Motor flange

- ZK: Diameter of centring circle
- LK: Diameter of pitch circles
- L: Length of motor shaft
- d: Diameter of motor shaft
- i: Centring height
- s: Thread

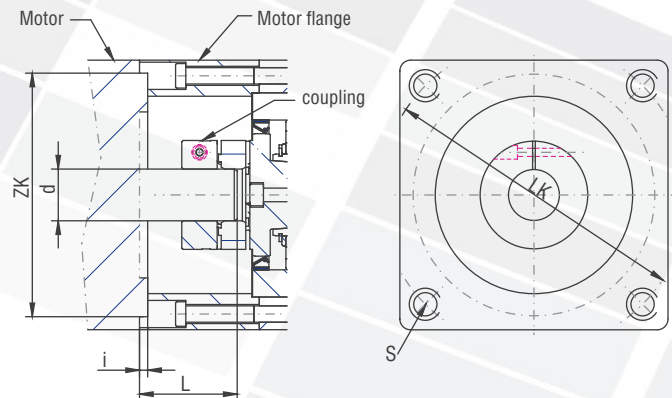

The values for the centring height (i) and the thread sizes (s) can be found on the respective pages. The flange tolerances are dimensioned for servo-motors of tolerance class N.

## 11.5 Type SC – Servo worm gearboxes

The values for the centring height (i) and the thread sizes (s) can be found on the respective pages.  
Fitting dimensions of the servo-motor – gearbox size/flange no. (selection)

d [mm] less than or equal to	L [mm]	LK [mm]	ZK [mm]	Gearbox size	Flange no.
11	23	63	40	040	002
	23	63	40	040	001
	23	75	60	040	102
	23	90	60	040	202
14	30	75	60	040	104
	30	95	50	040	301
	30	90	60	040	201
	30	75	60	040	103
	30	115	95	040	501
	30	100	80	040	401
19	40	165	110	040	802
	40	130	95	040	601
	40	130	110	040	611
	40	145	110	040	701
	40	165	110	050	802
	40	130	95	050	601
	40	95	50	050	301
	40	130	110	050	611
	40	90	60	050	201
	40	75	60	050	103
	40	115	95	050	501
	40	145	110	050	701
	40	100	80	050	401
	40	165	110	063	802
	40	130	95	063	601
	40	95	50	063	301
	40	130	110	063	611
	40	90	60	063	201
	40	75	60	063	103
	40	115	95	063	501
40	145	110	063	701	
40	100	80	063	401	
24	50	165	130	050	811
	50	165	130	063	811
	50	165	110	080	802
	50	165	130	080	811
	50	130	95	080	601
	50	95	50	080	301
	50	130	110	080	611
	50	90	60	080	201
	50	75	60	080	103
	50	115	95	080	501
	50	145	110	080	701
	50	100	80	080	401
32	60	100	80	080	403
	60	130	110	080	616
	60	215	130	080	902
	60	115	95	080	502
	60	215	180	080	911
	60	165	110	100	802
	60	165	130	100	811
	60	130	95	100	601
	60	130	110	100	611
	60	145	110	100	701
	60	100	80	100	403
	60	130	110	100	616
	60	215	130	100	902
	60	115	95	100	502
	60	215	180	100	911
38	80	215	180	080	932

Table 11.5.14-1

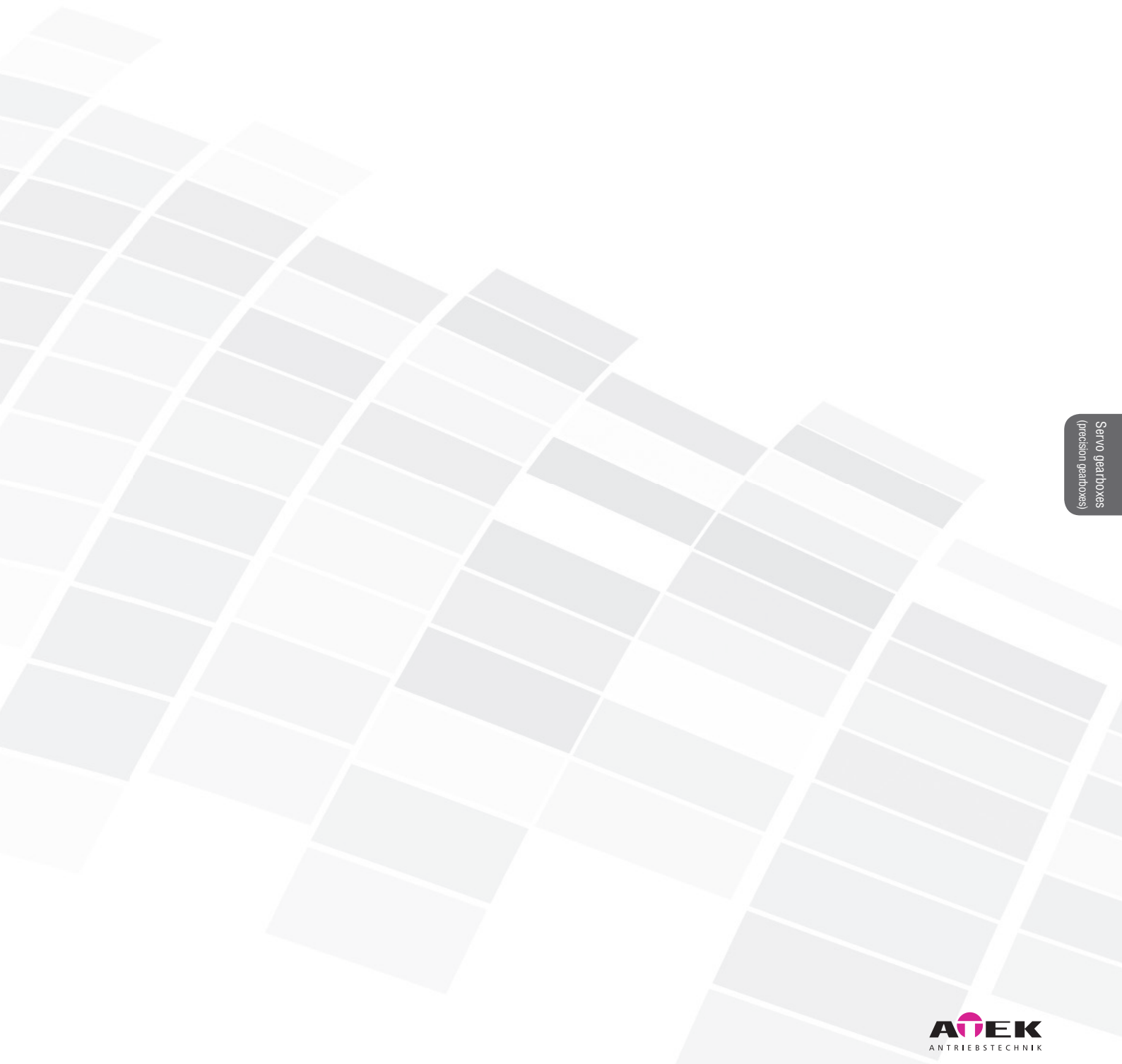

Servo gearboxes  
(precision gearboxes)

# 11.5 Type SC – Servo worm gearboxes

## 11.5.15 Features

- Gear ratios:  $i = 10:1$  to  $20:1$  ( $i > 26$  upon request)
- Maximum acceleration torques up to  $T_{2B} = 1100 \text{ Nm}$
- 5 gearbox sizes with 040 to 100 mm centre-to-centre distance
- Optimised efficiency
- Minimised circumferential backlash (optional)
- Worm gearboxes with square flange, suitable for fitting servo-motors
- Zero-play three-piece claw coupling

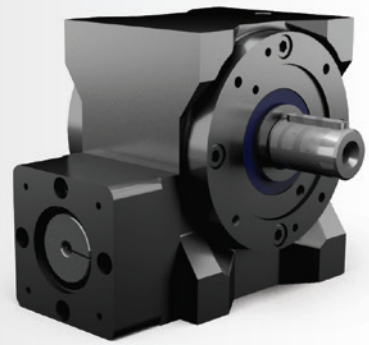

### 11.5.15.1 Models

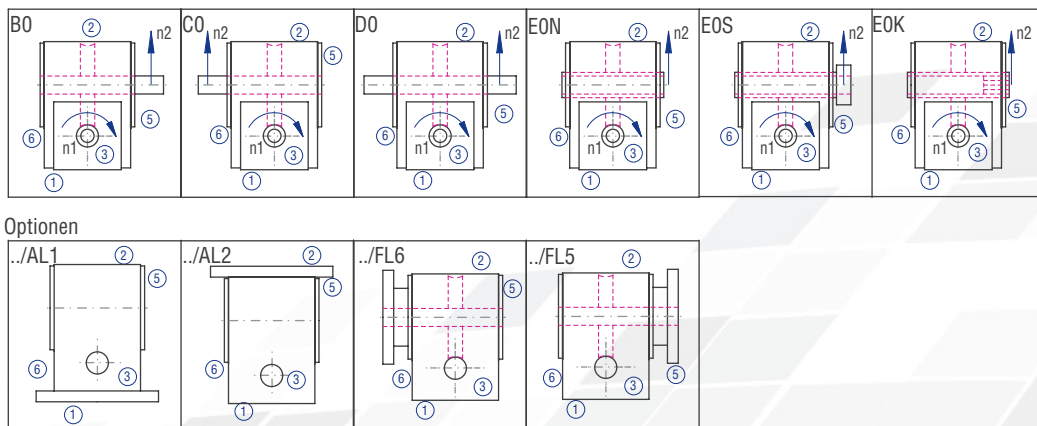

Figure 11.5.15-1; Models

### 11.5.15.2 Gearbox sides

The example shows the Model B0

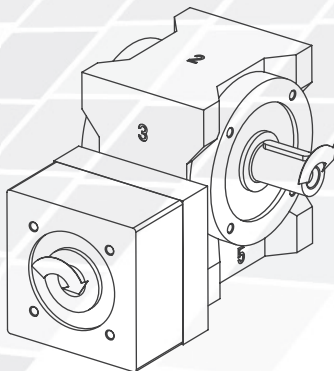

Figure 11.5.15-3; Gearbox sides

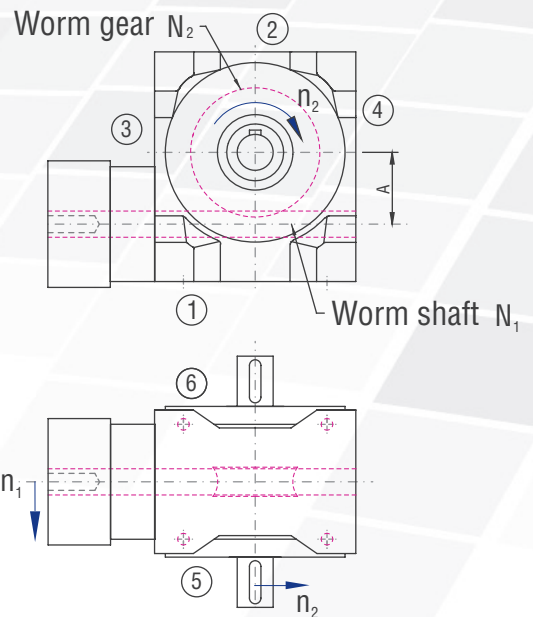

Figure 11.5.15-2; Shaft designations

### 11.5.15.3 Order code

The order code reflects the customer specifications. Example:

Type	Size	Gear ratio	Model	Fixing side	Installation position	Speed $n_2$	Design
SC	050	5:1	B0-	1.	1-	600	/0000
<b>Description</b>	Size; Table 11.5.15-1	Table 11.5.15-1	Figure 11.5.15-1	Side on which fixing is made; Table 11.5.4-1	Side directed downwards; Figure 4.3.1-1 Gearbox sides	Slowly rotating shaft Table 11.5.15-1	Will be determined by ATEK
	V080-		/	14 x 30	No. 301		KN
	Flange			Motor shaft $\varnothing$ x length	Flange no.		See chapter "Coupling"

## 11.5.15.4 Overview of performance data

The performance data and torques listed in the selection tables are only valid if the gearboxes are used in the installation positions 1, 5 or 6. If the worm shaft is vertical or located at the top (installation position 3, 4 or 2), 90% of the values specified must be expected.

Please enquire other gear ratios.

i(-)	n <sub>1</sub> [1/min]	i <sub>ist</sub>	n <sub>2</sub> [1/min]	040	050	063	080	100
				T <sub>2N</sub> [Nm]	T <sub>2N</sub> [Nm]	T <sub>2N</sub> [Nm]	T <sub>2N</sub> [Nm]	T <sub>2N</sub> [Nm]
10:1	4000	38:4	421		70,0			
		39:4	410	32,0		101,0		
		40:4	400				132,0	195,0
	3000	38:4	316		83,0			
		39:4	308	37,0		124,0		
		40:4	300				177,0	257,0
	2400	38:4	253		97,0			
		39:4	246	42,0		148,0		
		40:4	240				222,0	318,0
	1500	38:4	158		110,0			
		39:4	154	48,0		171,0		
		40:4	150				267,0	380,0
20:1	4000	38:2	211		72,0			
		39:2	205	36,0		116,0		
		40:2	200				153,0	236,0
	3000	38:2	158		85,0			
		39:2	154	41,0		141,0		
		40:2	150				203,0	308,0
	2400	38:2	126		98,0			
		39:2	123	46,0		166,0		
		40:2	120				253,0	380,0
	1500	38:2	79		111,0			
		39:2	77	51,0		190,0		
		40:2	75				303,0	452,0

	040	050	063	080	100
T <sub>2B</sub> (S5) [Nm]	50	112	216	408	1006
T <sub>2Not</sub> (S5) [Nm]	77	152	306	625	1090
N <sub>1</sub> max [U/min]	6000	5500	5000	4500	3200
T <sub>2B</sub> (S5) [Nm]	58	133	259	498	1112
T <sub>2Not</sub> (S5) [Nm]	90	179	355	725	1440
N <sub>1</sub> max [U/min]	6500	5500	5000	4500	3200

Table 11.5.15-1



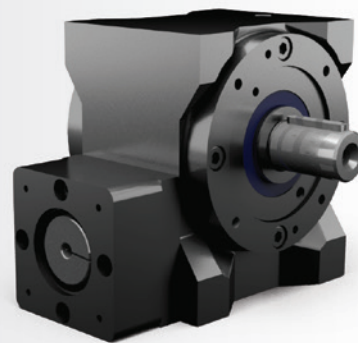

## Characteristics

Characteristic	Standard	Option
<b>Toothing</b>	Hardened and ground worm shaft / bronze worm gear	See chapter 11.5.2
<b>Gear ratio</b>	10:1 to 20:1	
<b>Housing / Flanges</b>	Grey cast iron / aluminium	
<b>Threaded mounting holes</b>	On gearbox side 1 and on the flanges	See chapter 11.5.4
<b>Shaft</b>	Material 1 C45, shaft ends greased Fit with ISO j6 tolerance with parallel keyway: according to DIN 6885 Sheet 1	See chapter 4.6.2
<b>Hollow shaft</b>	Material 1 C45, shafts greased Fit with ISO H7 tolerance with parallel keyway: according to DIN 6885 Sheet 1	See chapter 4.6.3
<b>Radial shaft seal ring</b>	NBR, form A	See chapter 4.8
<b>Ambient temperature</b>	-10°C to +90°C. The values of the performance tables are valid for +20°C	See chapter 4.9.3
<b>Circumferential backlash</b>	< 20 arcmin	See chapter 11.5.11
<b>Protection class</b>	IP 54	See chapter 4.5
<b>Corrosion protection</b>	Prime coat; layer thickness > 40 µm	See chapter 4.4.1
<b>Bearing life L10h</b>	more than 15,000h	See chapter 4.9.1
<b>Oil change intervals</b>	Not required if the oil temperature is kept < 90°C The lifetime of the bearings can be increased by the factor 1.5 if the oil is changed after the first 500 service hours and then every 5000 service hours.	See chapter 11.5.9
<b>Lubricants</b>	Synthetic lubricants	See chapter 11.5.9
<b>Motor flange</b>	Aluminium	See chapter 11.5.14
<b>Coupling</b>	Insertable, flexible claw coupling, suitable for servo-motors For smooth motor shafts      clamping hub For smooth motor shafts      tension ring hub For motor shafts with parallel key clamping hub with groove	KN SN KNN See chapter 11.5.13

## Torques in operating mode S1

I rated I ist	10:1		20:1	
	$n_2$ [1/min]	$T_{2N}$ [Nm]	$n_2$ [1/min]	$T_{2N}$ [Nm]
4000	410	32	205	36
3000	308	37	154	41
2400	246	42	123	46
1500	154	48	77	51

## Torques in operating mode S5

Coupling size	d [mm]	I rated $T_{2N}$ [Nm] $n_{1max}$ [U/min]	10:1		20:1	
			KN	KNN/SN	KN	KNN/SN
K14	9	$T_{2B}$ [Nm]	50,0	50,0	58,0	58,0
		$T_{2NOT}$ [Nm]	68,3	77,0	90,0	90,0
	11	$T_{2B}$ [Nm]	50,0	50,0	58,0	58,0
		$T_{2NOT}$ [Nm]	77,0	77,0	90,0	90,0
	14	$T_{2B}$ [Nm]	50,0	50,0	58,0	58,0
		$T_{2NOT}$ [Nm]	77,0	77,0	90,0	90,0
16	$T_{2B}$ [Nm]	50,0	50,0	58,0	58,0	
	$T_{2NOT}$ [Nm]	77,0	77,0	90,0	90,0	
K19	9	$T_{2B}$ [Nm]	50,0	50,0	58,0	58,0
		$T_{2NOT}$ [Nm]	77,0	77,0	90,0	90,0
	11	$T_{2B}$ [Nm]	50,0	50,0	58,0	58,0
		$T_{2NOT}$ [Nm]	77,0	77,0	90,0	90,0
	14	$T_{2B}$ [Nm]	50,0	50,0	58,0	58,0
		$T_{2NOT}$ [Nm]	77,0	77,0	90,0	90,0
	16	$T_{2B}$ [Nm]	50,0	50,0	58,0	58,0
		$T_{2NOT}$ [Nm]	77,0	77,0	90,0	90,0
	19	$T_{2B}$ [Nm]	50,0	50,0	58,0	58,0
		$T_{2NOT}$ [Nm]	77,0	77,0	90,0	90,0
	24	$T_{2B}$ [Nm]	50,0	50,0	58,0	58,0
		$T_{2NOT}$ [Nm]	77,0	77,0	90,0	90,0

## Permissible radial force $F_{r2}$ and axial force $F_{a2}$ on shaft $N_2$

$n_2$ [rpm]	200		125		75		50		30		10	
$T_2$ [Nm]	$F_r$ [N]	$F_a$ [N]	$F_r$ [N]	$F_a$ [N]	$F_r$ [N]	$F_a$ [N]	$F_r$ [N]	$F_a$ [N]	$F_r$ [N]	$F_a$ [N]	$F_r$ [N]	$F_a$ [N]
< 80	970	485	1250	625	1380	690	1600	800	1800	900	2500	1250

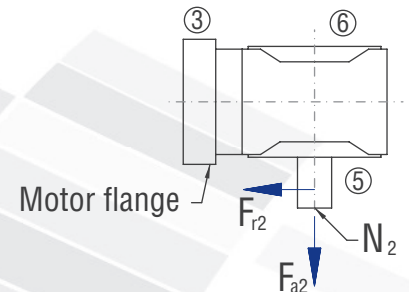

Servo gearboxes  
(precision gearboxes)

## Gearbox inertia moments/mass

Inertia moment  $J_1$  related to the fast-rotating shaft ( $N_1$ )

i rated [-]	Inertia moment [kgcm <sup>2</sup> ]							Mass ca. [kg]
	5:1	7.5:1	10:1	13:1	15:1	20:1	26:1	
$J$ [kgcm <sup>2</sup> ]	0.3307	0.2454	0.1801	0.1458	0.1943	0.1476	0.1268	7

## Inertia moment Coupling J

	Inertia moment [kgcm <sup>2</sup> ]		
	KN J [kgcm <sup>2</sup> ]	KNN J [kgcm <sup>2</sup> ]	SN J [kgcm <sup>2</sup> ]
<b>K14</b>	0.0606	0.0606	0.1446
<b>K19</b>	0.4229	0.4229	0.6349

The mass of the gearbox may deviate depending on the flange size and the gear ratio.

# 11.5.16 Type SC 040 – Servo worm gearboxes

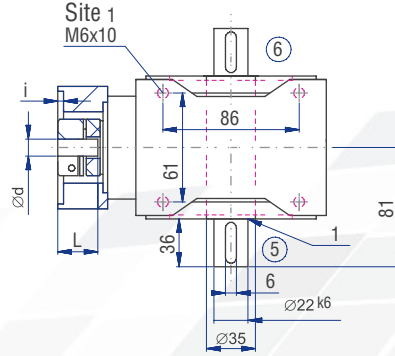
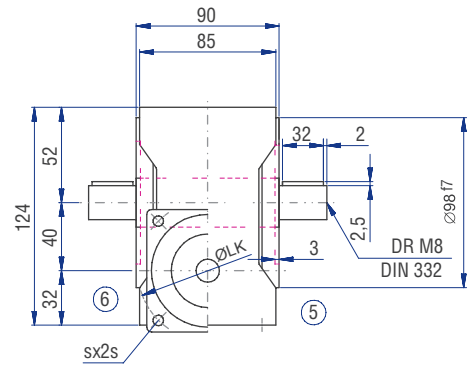
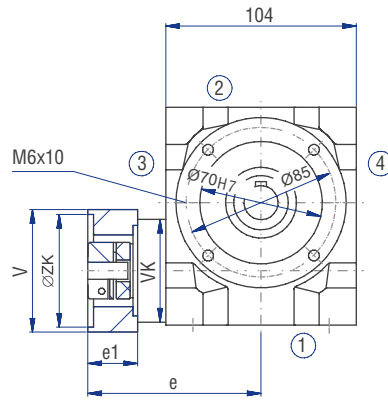
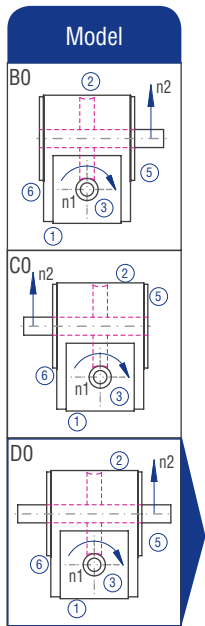

## Implementation VV

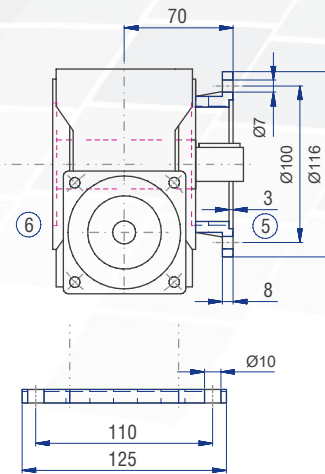
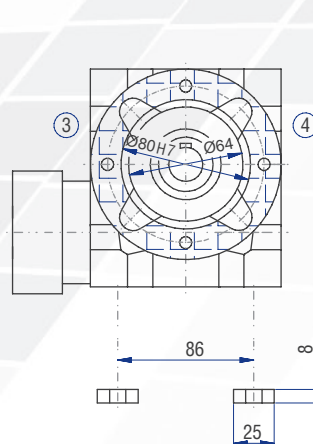
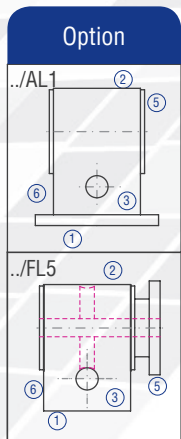
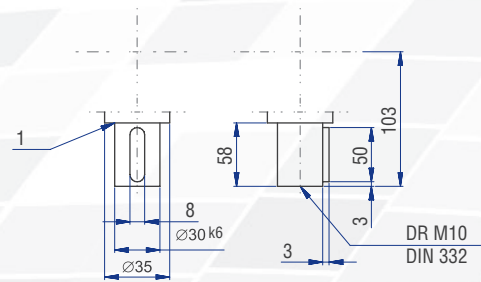

## Motor dimensions

Flange no.	Motor shaft (dxL)	Thread (s)	V [mm]	ZK [mm]	LK [mm]	i [mm]	e [mm]	e1 [mm]
001	11*23	M4	65	40	63	3	93.0	30.0
002	11*23	M5	65	40	63	3	93.0	30.0
102	11*23	M5	65	60	75	3	90.0	26.5
202	11*23	M5	65	60	90	4	90.0	26.5
103	14*30	M6	65	60	75	3	108.5	45.0
104	14*30	M5	65	60	75	3	108.5	45.0
201	14*30	M5	65	60	90	4	108.5	45.0
301	14*30	M6	65	50	95	4	108.5	45.0
401	14*30	M6	65	80	100	4	108.5	45.0
501	14*30	M8	65	95	115	4	108.5	45.0
601	19*40	M8	90	95	130	4	121.0	45.0
611	19*40	M8	90	110	130	5	121.0	45.0
701	19*40	M8	90	110	145	5	121.0	45.0
802	19*40	M10	90	110	165	5	121.0	45.0

The dimensions e and e1 will change for the coupling type "clamping hub with groove" (KNN). Please contact us for consultation!

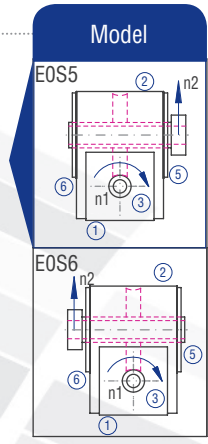
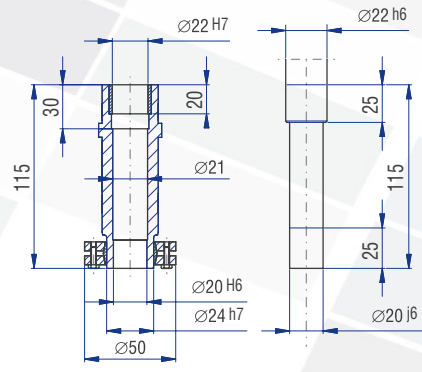
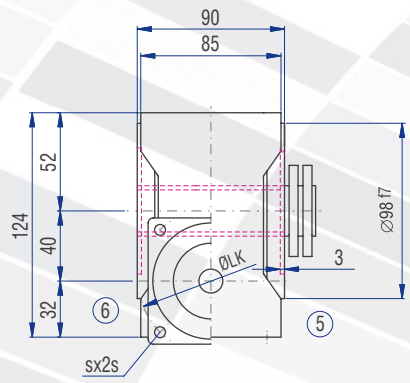
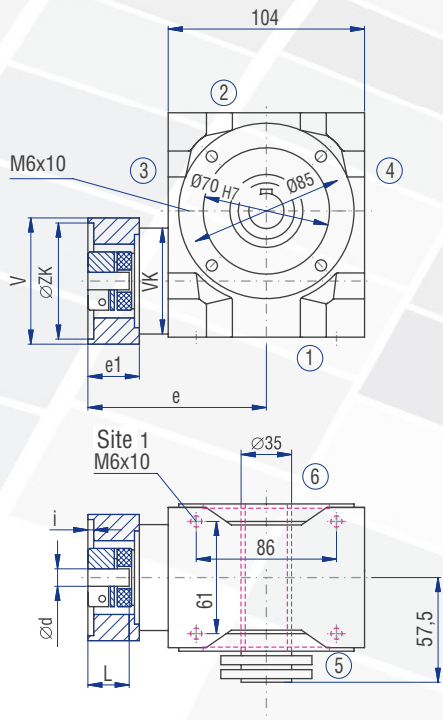
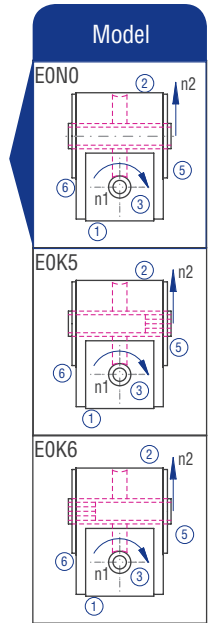
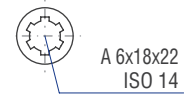
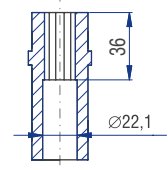
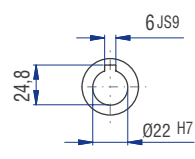
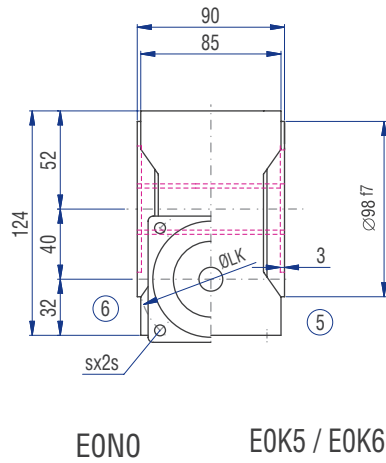
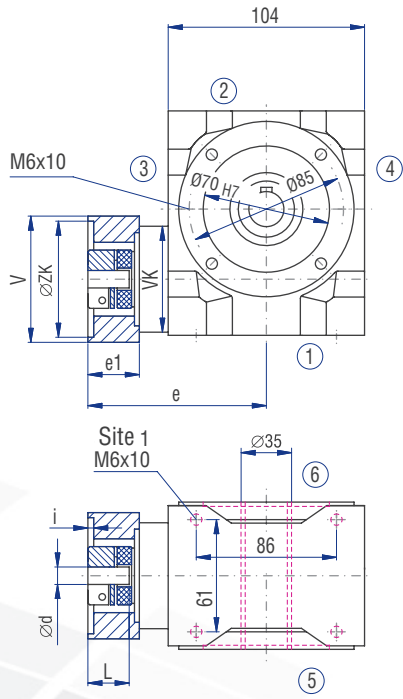

Servo gearboxes  
(precision gearboxes)

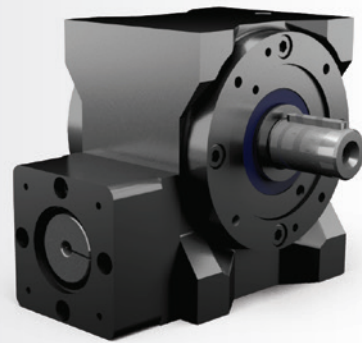

## Characteristics

Characteristic	Standard	Option
<b>Toothing</b>	Hardened and ground worm shaft / bronze worm gear	See chapter 11.5.2
<b>Gear ratio</b>	10:1 to 20:1	
<b>Housing / Flanges</b>	Grey cast iron / aluminium	
<b>Threaded mounting holes</b>	On gearbox side 1 and on the flanges	See chapter 11.5.4
<b>Shaft</b>	Material 1 C45, shaft ends greased Fit with ISO j6 tolerance with parallel keyway: according to DIN 6885 Sheet 1	See chapter 4.6.2
<b>Hollow shaft</b>	Material 1 C45, shafts greased Fit with ISO H7 tolerance with parallel keyway: according to DIN 6885 Sheet 1	See chapter 4.6.3
<b>Radial shaft seal ring</b>	NBR, form A	See chapter 4.8
<b>Ambient temperature</b>	-10°C to +90°C. The values of the performance tables are valid for +20°C	See chapter 4.9.3
<b>Circumferential backlash</b>	< 20 arcmin	See chapter 11.5.11
<b>Protection class</b>	IP 54	See chapter 4.5
<b>Corrosion protection</b>	Prime coat; layer thickness > 40 µm	See chapter 4.4.1
<b>Bearing life L10h</b>	more than 15,000h	See chapter 4.9.1
<b>Oil change intervals</b>	Not required if the oil temperature is kept < 90°C The lifetime of the bearings can be increased by the factor 1.5 if the oil is changed after the first 500 service hours and then every 5000 service hours.	See chapter 11.5.9
<b>Lubricants</b>	Synthetic lubricants	See chapter 11.5.9
<b>Motor flange</b>	Aluminium	See chapter 11.5.14
<b>Coupling</b>	Insertable, flexible claw coupling, suitable for servo-motors For smooth motor shafts      clamping hub      KN For smooth motor shafts      tension ring hub      SN For motor shafts with parallel key clamping hub with groove      KNN	See chapter 11.5.13

## Torques in operating mode S1

I rated I ist	10:1		20:1	
	$n_2$ [1/min]	$T_{2N}$ [Nm]	$n_2$ [1/min]	$T_{2N}$ [Nm]
4000	421	70	211	72
3000	316	83	158	85
2400	253	97	126	98
1500	158	110	79	111

## Torques in operating mode S5

Coupling size	d [mm]	I rated $T_{2N}$ [Nm] $n_{1max}$ [U/min]	10:1		20:1	
			KN	KNN/SN	KN	KNN/SN
K19	9	$T_{2B}$ [Nm]	112,0		133,0	
		$T_{2NOT}$ [Nm]	152,0		179,0	
	11	$T_{2B}$ [Nm]	112,0	112,0	133,0	133,0
		$T_{2NOT}$ [Nm]	152,0	152,0	179,0	179,0
	14	$T_{2B}$ [Nm]	112,0	112,0	133,0	133,0
		$T_{2NOT}$ [Nm]	152,0	152,0	179,0	179,0
	16	$T_{2B}$ [Nm]	112,0	112,0	133,0	133,0
		$T_{2NOT}$ [Nm]	152,0	152,0	179,0	179,0
	19	$T_{2B}$ [Nm]	112,0	112,0	133,0	133,0
		$T_{2NOT}$ [Nm]	152,0	152,0	179,0	179,0
	24	$T_{2B}$ [Nm]	112,0		133,0	
		$T_{2NOT}$ [Nm]	152,0		179,0	
K24	11	$T_{2B}$ [Nm]	112,0	112,0	133,0	133,0
		$T_{2NOT}$ [Nm]	152,0	0,0	179,0	0,0
	14	$T_{2B}$ [Nm]	112,0	112,0	133,0	133,0
		$T_{2NOT}$ [Nm]	152,0	152,0	179,0	179,0
	16	$T_{2B}$ [Nm]	112,0	112,0	133,0	133,0
		$T_{2NOT}$ [Nm]	152,0	152,0	179,0	179,0
	19	$T_{2B}$ [Nm]	112,0	112,0	133,0	133,0
		$T_{2NOT}$ [Nm]	152,0	152,0	179,0	179,0
	24	$T_{2B}$ [Nm]	112,0	112,0	133,0	133,0
		$T_{2NOT}$ [Nm]	152,0	152,0	179,0	179,0
	28	$T_{2B}$ [Nm]	112,0	112,0	133,0	133,0
		$T_{2NOT}$ [Nm]	152,0	152,0	179,0	179,0

## Permissible radial force $F_{r2}$ and axial force $F_{a2}$ on shaft $N_2$

$n_2$ [rpm]	200		125		75		50		30		10	
$T_2$ [Nm]	$F_r$ [N]	$F_a$ [N]	$F_r$ [N]	$F_a$ [N]	$F_r$ [N]	$F_a$ [N]	$F_r$ [N]	$F_a$ [N]	$F_r$ [N]	$F_a$ [N]	$F_r$ [N]	$F_a$ [N]
< 120	2000	1000	2400	1200	2850	1425	3350	1675	4000	2000	4800	2400
> 120	1540	770	1850	925	2190	1095	2580	1290	3080	1540	3700	1850

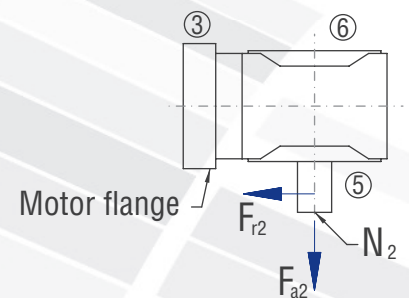

## Gearbox inertia moments/mass

Inertia moment  $J_1$  related to the fast-rotating shaft ( $N_1$ )

i rated [-]	Inertia moment [kgcm <sup>2</sup> ]						
	5:1	7.5:1	10:1	13:1	15:1	20:1	26:1
$J$ [kgcm <sup>2</sup> ]	0.9509	0.7327	0.5820	0.4876	0.6017	0.4996	0.4375

Mass ca. [kg]
13

## Inertia moments Coupling J

	KN	KNN	SN
	J [kgcm <sup>2</sup> ]	J [kgcm <sup>2</sup> ]	J [kgcm <sup>2</sup> ]
K19	0.4229	0.4229	0.6349
K24	1.0910	1.0910	2.7750

The mass of the gearbox may deviate depending on the flange size and the gear ratio.

Servo gearboxes  
(precision gearboxes)

# 11.5.17 Type SC 050 – Servo worm gearboxes

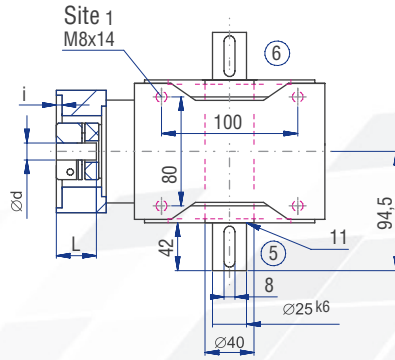
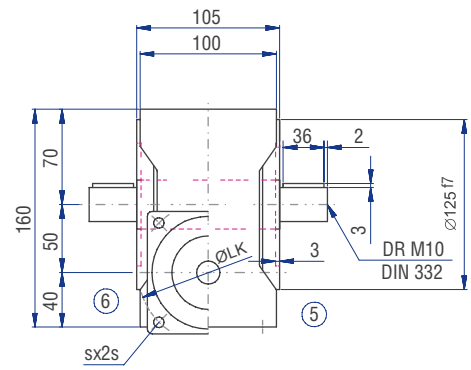
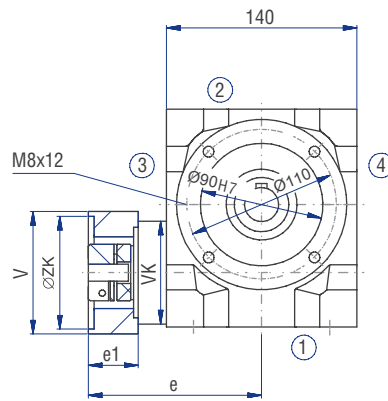
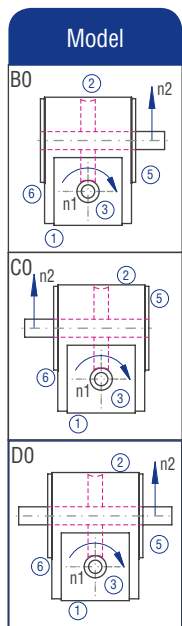

## Implementation VV

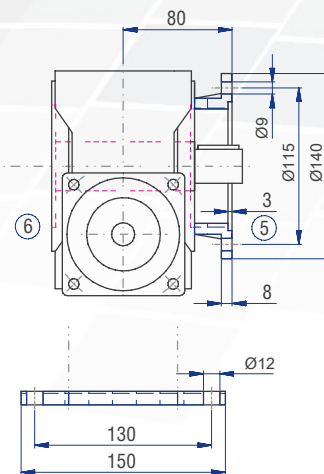
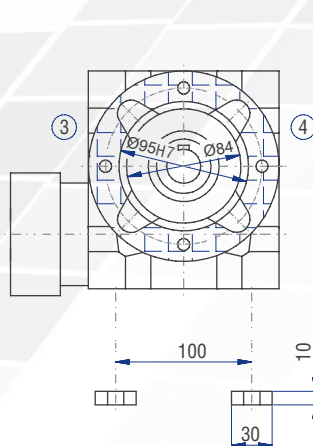
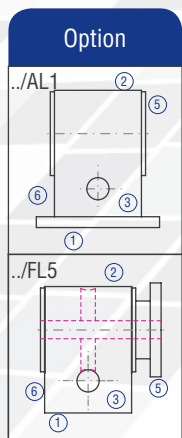
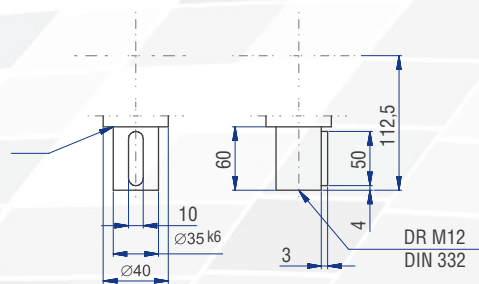

## Motor dimensions

Flange no.	Motor shaft (dxL)	Thread (s)	V [mm]	ZK [mm]	LK [mm]	i [mm]	e [mm]	e1 [mm]
103	19*40	M6	90	60	75	3	141.0	45.0
201	19*40	M5	90	60	90	3	141.0	45.0
301	19*40	M6	90	50	95	4	141.0	45.0
401	19*40	M6	90	80	100	4	141.0	45.0
501	19*40	M8	90	95	115	4	141.0	45.0
601	19*40	M8	90	95	130	4	141.0	45.0
611	19*40	M8	90	110	130	5	141.0	45.0
701	19*40	M8	90	110	145	5	141.0	45.0
802	19*40	M10	90	110	165	5	141.0	45.0
811	24*50	M10	120	130	165	5	155.0	54.0

The dimensions e and e1 will change for the coupling type “clamping hub with groove” (KNN). Please contact us for consultation!

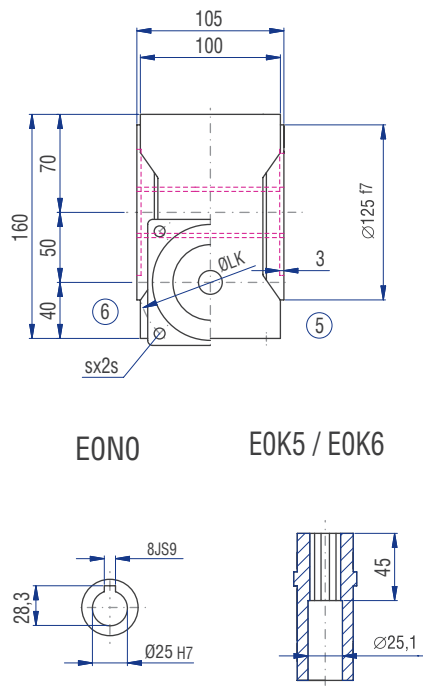
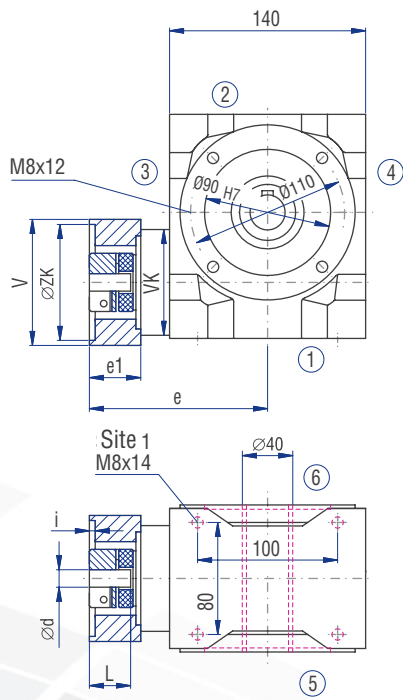

EON0

EOK5 / EOK6

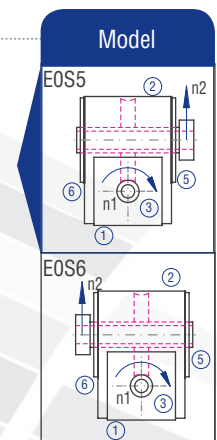
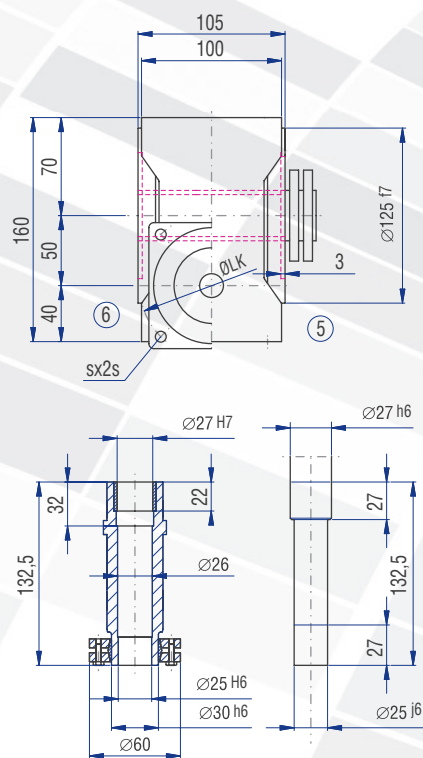
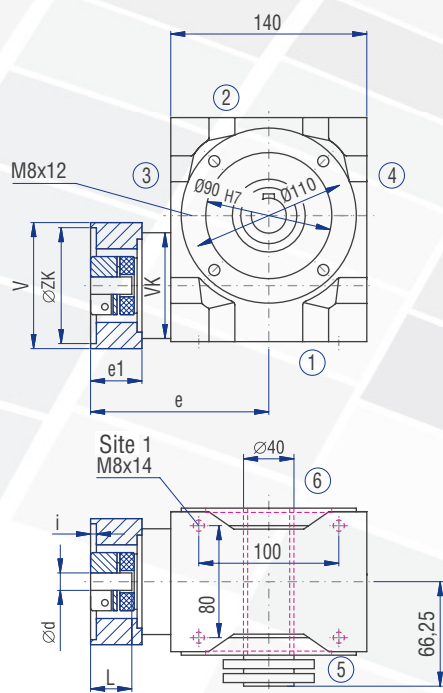
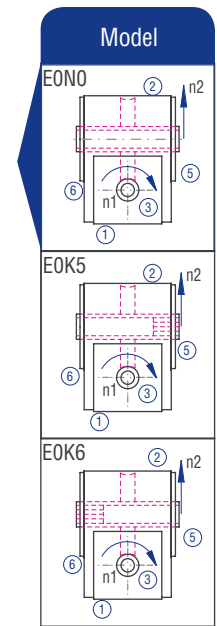
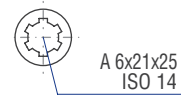

Servo gearboxes  
(precision gearboxes)



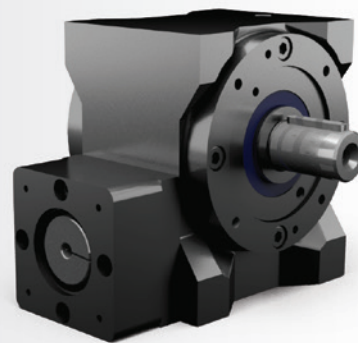

## Characteristics

Characteristic	Standard	Option
<b>Toothing</b>	Hardened and ground worm shaft / bronze worm gear	See chapter 11.5.2
<b>Gear ratio</b>	10:1 to 20:1	
<b>Housing / Flanges</b>	Grey cast iron / aluminium	
<b>Threaded mounting holes</b>	On gearbox side 1 and on the flanges	See chapter 11.5.4
<b>Shaft</b>	Material 1 C45, shaft ends greased Fit with ISO j6 tolerance with parallel keyway: according to DIN 6885 Sheet 1	See chapter 4.6.2
<b>Hollow shaft</b>	Material 1 C45, shafts greased Fit with ISO H7 tolerance with parallel keyway: according to DIN 6885 Sheet 1	See chapter 4.6.3
<b>Radial shaft seal ring</b>	NBR, form A	See chapter 4.8
<b>Ambient temperature</b>	-10°C to +90°C. The values of the performance tables are valid for +20°C	See chapter 4.9.3
<b>Circumferential backlash</b>	< 20 arcmin	See chapter 11.5.11
<b>Protection class</b>	IP 54	See chapter 4.5
<b>Corrosion protection</b>	Prime coat; layer thickness > 40 µm	See chapter 4.4.1
<b>Bearing life L10h</b>	more than 15,000h	See chapter 4.9.1
<b>Oil change intervals</b>	Not required if the oil temperature is kept < 90°C The lifetime of the bearings can be increased by the factor 1.5 if the oil is changed after the first 500 service hours and then every 5000 service hours.	See chapter 11.5.9
<b>Lubricants</b>	Synthetic lubricants	See chapter 11.5.9
<b>Motor flange</b>	Aluminium	See chapter 11.5.14
<b>Coupling</b>	Insertable, flexible claw coupling, suitable for servo-motors For smooth motor shafts      clamping hub      KN For smooth motor shafts      tension ring hub      SN For motor shafts with parallel key clamping hub with groove      KNN	See chapter 11.5.13

Table 9-13

## Torques in operating mode S1

I rated I ist	10:1		20:1	
	$n_2$ [1/min]	$T_{2N}$ [Nm]	$n_2$ [1/min]	$T_{2N}$ [Nm]
4000	410	101	205	116
3000	308	124	154	141
2400	246	148	123	166
1500	154	171	77	190

## Torques in operating mode S5

Coupling size	d [mm]	I rated $T_{2N}$ [Nm] $n_{1max}$ [U/min]	10:1		20:1	
			KN	KNN/SN	KN	KNN/SN
K19	9	$T_{2B}$ [Nm]	165,8		259,0	
		$T_{2NOT}$ [Nm]	292,5		355,0	
	11	$T_{2B}$ [Nm]	165,8	165,8	259,0	259,0
		$T_{2NOT}$ [Nm]	292,5	292,5	355,0	355,0
	14	$T_{2B}$ [Nm]	165,8	165,8	259,0	259,0
		$T_{2NOT}$ [Nm]	306,0	306,0	355,0	355,0
	16	$T_{2B}$ [Nm]	165,8	165,8	259,0	259,0
		$T_{2NOT}$ [Nm]	306,0	306,0	355,0	355,0
	19	$T_{2B}$ [Nm]	165,8	165,8	259,0	259,0
		$T_{2NOT}$ [Nm]	306,0	306,0	355,0	355,0
	24	$T_{2B}$ [Nm]	165,8		259,0	
		$T_{2NOT}$ [Nm]	306,0		355,0	
K24	11	$T_{2B}$ [Nm]	216,0	216,0	259,0	259,0
		$T_{2NOT}$ [Nm]	306,0	0,0	355,0	0,0
	14	$T_{2B}$ [Nm]	216,0	216,0	259,0	259,0
		$T_{2NOT}$ [Nm]	306,0	306,0	355,0	355,0
	16	$T_{2B}$ [Nm]	216,0	216,0	259,0	259,0
		$T_{2NOT}$ [Nm]	306,0	306,0	355,0	355,0
	19	$T_{2B}$ [Nm]	216,0	216,0	259,0	259,0
		$T_{2NOT}$ [Nm]	306,0	306,0	355,0	355,0
	24	$T_{2B}$ [Nm]	216,0	216,0	259,0	259,0
		$T_{2NOT}$ [Nm]	306,0	306,0	355,0	355,0
	28	$T_{2B}$ [Nm]	216,0	216,0	259,0	259,0
		$T_{2NOT}$ [Nm]	306,0	306,0	355,0	355,0

## Permissible radial force $F_{r2}$ and axial force $F_{a2}$ on shaft $N_2$

$n_2$ [rpm]	200		125		75		50		30		10	
$T_2$ [Nm]	$F_r$ [N]	$F_a$ [N]	$F_r$ [N]	$F_a$ [N]	$F_r$ [N]	$F_a$ [N]	$F_r$ [N]	$F_a$ [N]	$F_r$ [N]	$F_a$ [N]	$F_r$ [N]	$F_a$ [N]
< 220	2700	1350	3150	1575	3800	1900	4500	2250	5200	2600	5200	2600
> 220	2080	1040	2420	1210	2920	1460	3460	1730	4000	2000	4000	2000

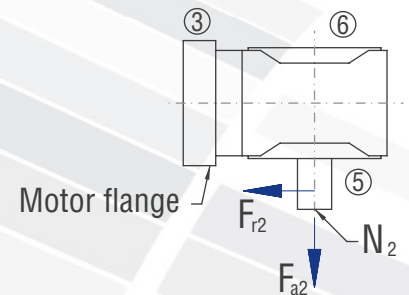

## Gearbox inertia moments/mass

Inertia moment  $J_1$  related to the fast-rotating shaft ( $N_1$ )

i rated [-]	Inertia moment [kgcm <sup>2</sup> ]						
	5:1	7.5:1	10:1	13:1	15:1	20:1	26:1
J [kgcm <sup>2</sup> ]	2.1678	1.6423	1.1366	0.9368	1.3270	0.9445	0.8175

Mass ca. [kg]
20

## Inertia moments Coupling J

	KN	KNN	SN
	J [kgcm <sup>2</sup> ]	J [kgcm <sup>2</sup> ]	J [kgcm <sup>2</sup> ]
K19	0.4229	0.4229	0.6349
K24	1.0910	1.0910	2.7750

The mass of the gearbox may deviate depending on the flange size and the gear ratio.

Servo gearboxes  
(precision gearboxes)

# 11.5.18 Type SC 063 – Servo worm gearboxes

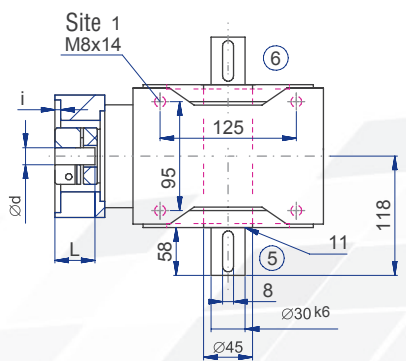
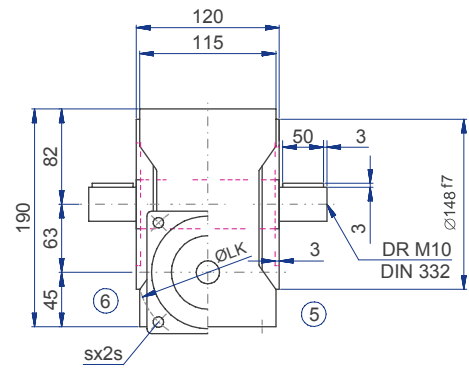
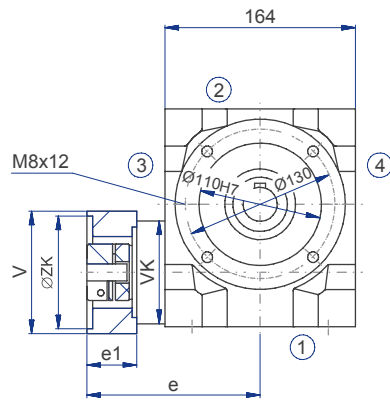
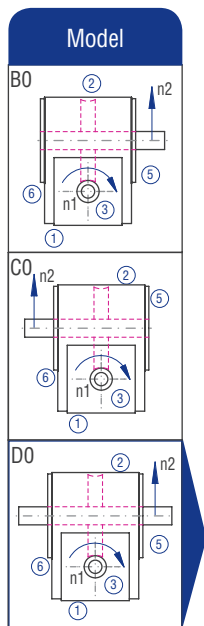

## Implementation VV

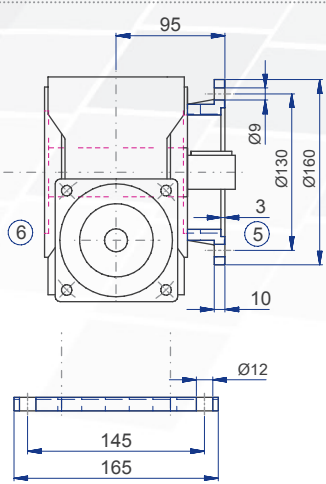
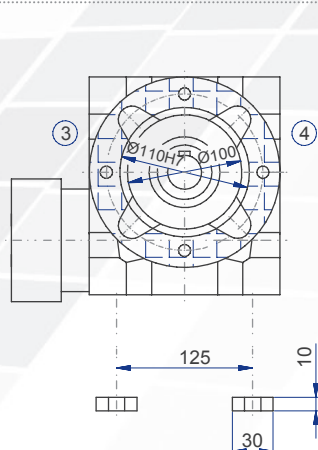
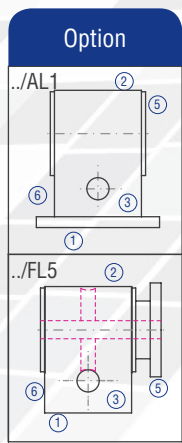
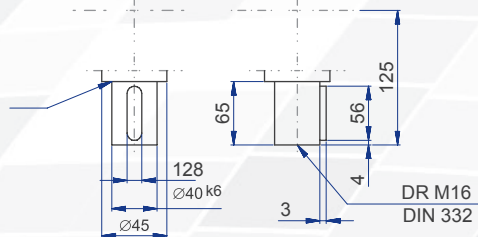

## Motor dimensions

Flange no.	Motor shaft (dxL)	Thread (s)	V [mm]	ZK [mm]	LK [mm]	i [mm]	e [mm]	e1 [mm]
103	19*40	M6	90	60	75	3	154.0	45.0
201	19*40	M5	90	60	90	3	154.0	45.0
301	19*40	M6	90	50	95	4	154.0	45.0
401	19*40	M6	90	80	100	4	154.0	45.0
501	19*40	M8	90	95	115	4	154.0	45.0
601	19*40	M8	90	95	130	4	154.0	45.0
611	19*40	M8	90	110	130	5	154.0	45.0
701	19*40	M8	90	110	145	5	154.0	45.0
802	19*40	M10	90	110	165	5	154.0	45.0
811	24*50	M10	120	130	165	5	177.0	54.0

The dimensions e and e1 will change for the coupling type "clamping hub with groove" (KNN). Please contact us for consultation!



The dimensions of the Models not shown can be figured by mirroring available dimensions.

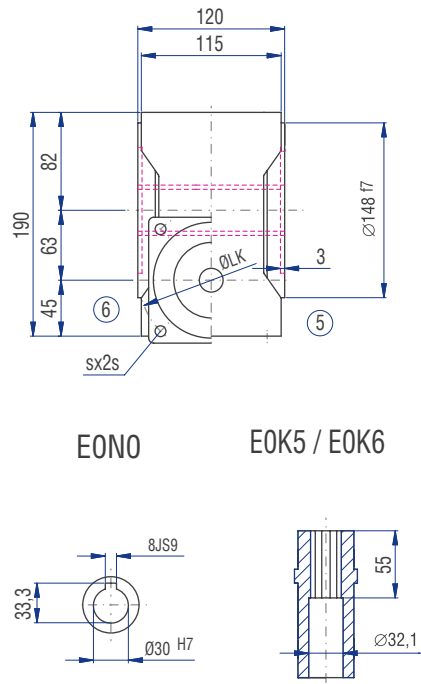
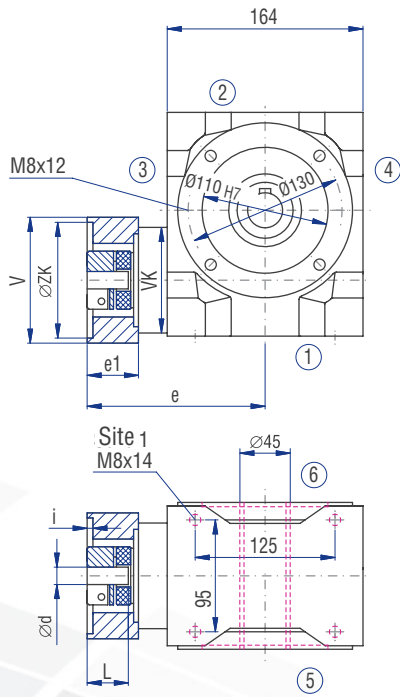

EON0

EOK5 / EOK6

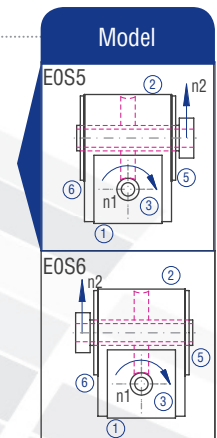
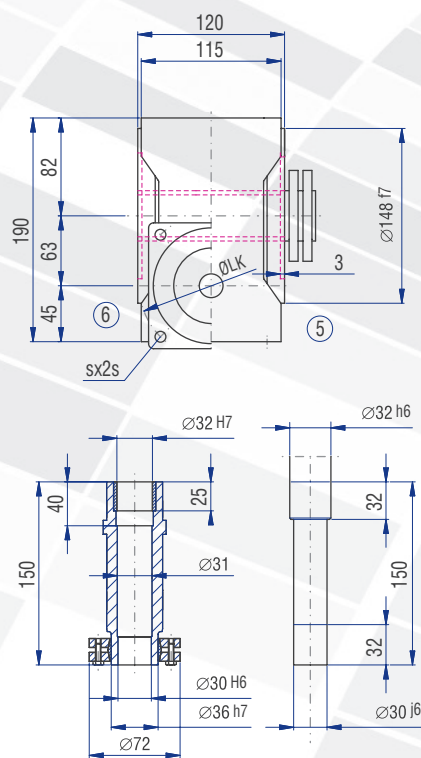
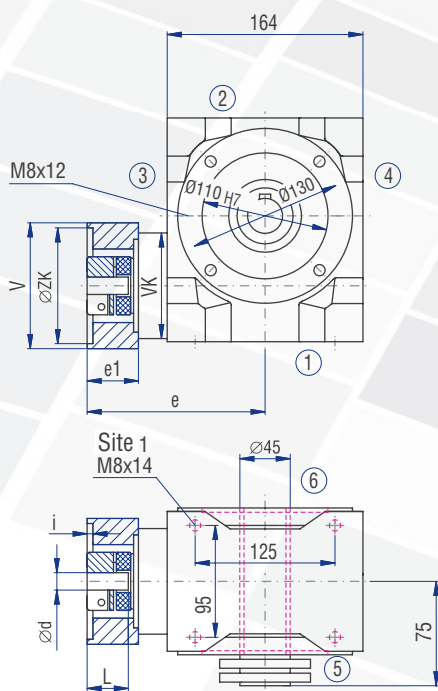
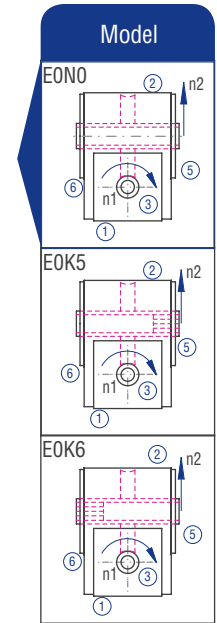
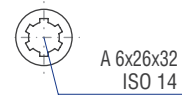

Servo gearboxes  
(precision gearboxes)

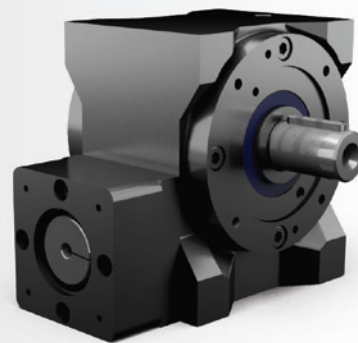

## Characteristics

Characteristic	Standard	Option
<b>Toothing</b>	Hardened and ground worm shaft / bronze worm gear	See chapter 11.5.2
<b>Gear ratio</b>	10:1 to 20:1	
<b>Housing / Flanges</b>	Grey cast iron / aluminium	
<b>Threaded mounting holes</b>	On gearbox side 1 and on the flanges	See chapter 11.5.4
<b>Shaft</b>	Material 1 C45, shaft ends greased Fit with ISO j6 tolerance with parallel keyway: according to DIN 6885 Sheet 1	See chapter 4.6.2
<b>Hollow shaft</b>	Material 1 C45, shafts greased Fit with ISO H7 tolerance with parallel keyway: according to DIN 6885 Sheet 1	See chapter 4.6.3
<b>Radial shaft seal ring</b>	NBR, form A	See chapter 4.8
<b>Ambient temperature</b>	-10°C to +90°C. The values of the performance tables are valid for +20°C	See chapter 4.9.3
<b>Circumferential backlash</b>	< 20 arcmin	See chapter 11.5.11
<b>Protection class</b>	IP 54	See chapter 4.5
<b>Corrosion protection</b>	Prime coat; layer thickness > 40 µm	See chapter 4.4.1
<b>Bearing life L10h</b>	more than 15,000h	See chapter 4.9.1
<b>Oil change intervals</b>	Not required if the oil temperature is kept < 90°C The lifetime of the bearings can be increased by the factor 1.5 if the oil is changed after the first 500 service hours and then every 5000 service hours.	See chapter 11.5.9
<b>Lubricants</b>	Synthetic lubricants	See chapter 11.5.9
<b>Motor flange</b>	Aluminium	See chapter 11.5.14
<b>Coupling</b>	Insertable, flexible claw coupling, suitable for servo-motors For smooth motor shafts      clamping hub      KN For smooth motor shafts      tension ring hub      SN For motor shafts with parallel key clamping hub with groove      KNN	See chapter 11.5.13

## Torques in operating mode S1

I rated I ist	10:1		20:1	
	$n_2$ [1/min]	$T_{2N}$ [Nm]	$n_2$ [1/min]	$T_{2N}$ [Nm]
4000	400	132	200	153
3000	300	177	150	203
2400	240	222	120	253
1500	150	267	75	303

## Torques in operating mode S5

Coupling size	d [mm]	I rated $T_{2N}$ [Nm] $n_{1max}$ [U/min]	10:1		20:1	
			KN	KNN/SN	KN	KNN/SN
K24	11	$T_{2B}$ [Nm]	350,0	408,0	498,0	498,0
		$T_{2NOT}$ [Nm]	450,0	0,0	725,0	0,0
	14	$T_{2B}$ [Nm]	360,0	408,0	498,0	498,0
		$T_{2NOT}$ [Nm]	450,0	625,0	725,0	725,0
	16	$T_{2B}$ [Nm]	390,0	408,0	498,0	498,0
		$T_{2NOT}$ [Nm]	500,0	625,0	725,0	725,0
	19	$T_{2B}$ [Nm]	390,0	408,0	498,0	498,0
		$T_{2NOT}$ [Nm]	600,0	625,0	725,0	725,0
	24	$T_{2B}$ [Nm]	408,0	408,0	498,0	498,0
		$T_{2NOT}$ [Nm]	625,0	625,0	725,0	725,0
	28	$T_{2B}$ [Nm]	408,0	408,0	498,0	498,0
		$T_{2NOT}$ [Nm]	625,0	625,0	725,0	725,0
K28	14	$T_{2B}$ [Nm]	408,0		498,0	
		$T_{2NOT}$ [Nm]	625,0		725,0	
	16	$T_{2B}$ [Nm]	408,0	408,0	498,0	498,0
		$T_{2NOT}$ [Nm]	625,0	625,0	725,0	725,0
	19	$T_{2B}$ [Nm]	408,0	408,0	498,0	498,0
		$T_{2NOT}$ [Nm]	625,0	625,0	725,0	725,0
	24	$T_{2B}$ [Nm]	408,0	408,0	498,0	498,0
		$T_{2NOT}$ [Nm]	625,0	625,0	725,0	725,0
	28	$T_{2B}$ [Nm]	408,0	408,0	498,0	498,0
		$T_{2NOT}$ [Nm]	625,0	625,0	725,0	725,0
	32	$T_{2B}$ [Nm]	408,0	408,0	498,0	498,0
		$T_{2NOT}$ [Nm]	625,0	625,0	725,0	725,0
38	$T_{2B}$ [Nm]	408,0	408,0	498,0	498,0	
	$T_{2NOT}$ [Nm]	625,0	0,0	725,0	0,0	

Servo gearboxes  
(precision gearboxes)

## Permissible radial force $F_{r2}$ and axial force $F_{a2}$ on shaft $N_2$

$n_2$ [rpm]	200		125		75		50		30		10	
$T_2$ [Nm]	$F_r$ [N]	$F_a$ [N]	$F_r$ [N]	$F_a$ [N]	$F_r$ [N]	$F_a$ [N]	$F_r$ [N]	$F_a$ [N]	$F_r$ [N]	$F_a$ [N]	$F_r$ [N]	$F_a$ [N]
< 430	3300	1650	3750	1875	4500	2250	5300	2650	6300	3150	7600	3800
> 430	2640	1320	3000	1500	3600	1800	4240	2120	5040	2520	6080	3040

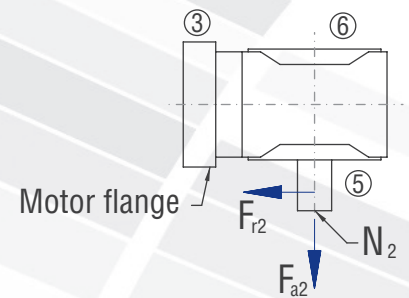

## Gearbox inertia moments/mass

Inertia moment  $J_1$  related to the fast-rotating shaft ( $N_1$ )

i rated [-]	Inertia moment [kgcm <sup>2</sup> ]							Mass ca. [kg]
	5:1	7.5:1	10:1	13:1	15:1	20:1	26:1	
$J$ [kgcm <sup>2</sup> ]	5.8195	4.2167	2.9560	2.2634	3.2550	2.3977	1.9066	30

## Inertia moments Coupling J

	KN	KNN	SN
	J [kgcm <sup>2</sup> ]	J [kgcm <sup>2</sup> ]	J [kgcm <sup>2</sup> ]
K24	1.0910	1.0910	2.7750
K28	4.1710	4.1710	6.4250

The mass of the gearbox may deviate depending on the flange size and the gear ratio.

# 11.5.19 Type SC 080 – Servo worm gearboxes

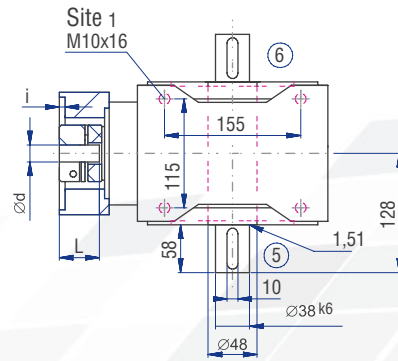
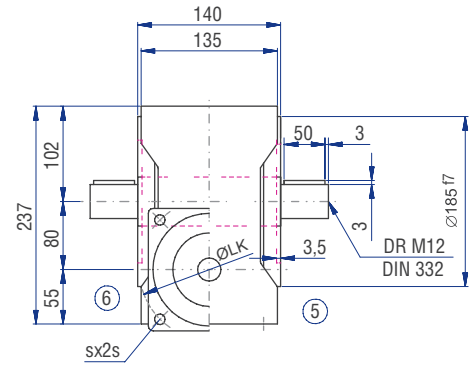
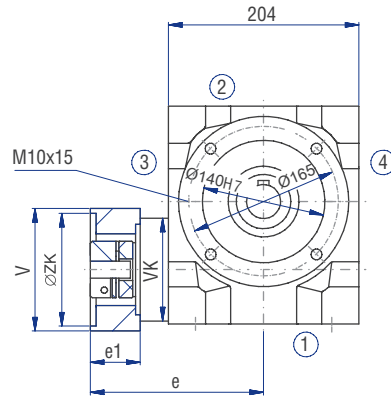
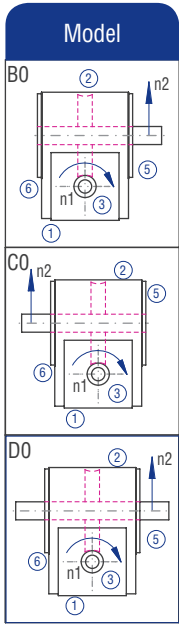

## Implementation VV

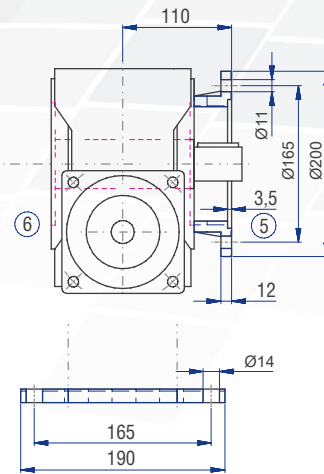
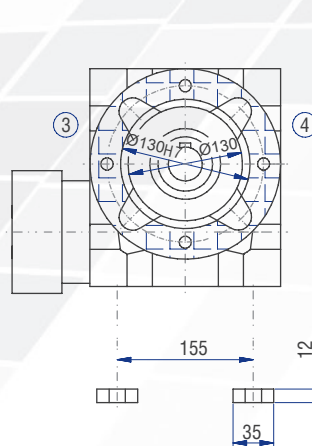
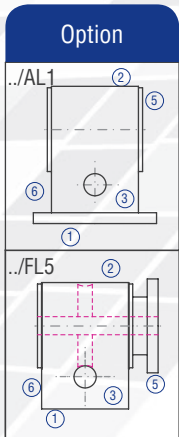
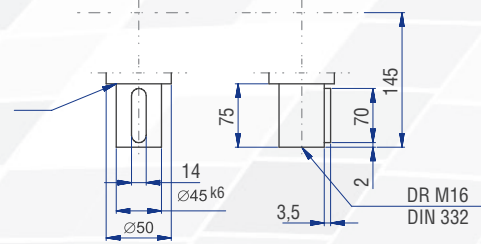

## Motor dimensions

Flange no.	Motor shaft (dxL)	Thread (s)	V [mm]	ZK [mm]	LK [mm]	i [mm]	e [mm]	e1 [mm]
103	24*50	M6	120	60	75	3	192.5	54.0
201	24*50	M5	120	60	90	3	192.5	54.0
301	24*50	M6	120	50	95	4	192.5	54.0
401	24*50	M6	120	80	100	4	192.5	54.0
501	24*50	M8	120	95	115	4	192.5	54.0
601	24*50	M8	120	95	130	4	192.5	54.0
611	24*50	M8	120	110	130	5	192.5	54.0
701	24*50	M8	120	110	145	5	192.5	54.0
802	24*50	M10	120	110	165	5	192.5	54.0
811	24*50	M10	120	130	165	5	192.5	54.0
403	32*60	M6	140	80	100	4	202.5	61.0
502	32*60	M8	140	95	115	4	202.5	61.0
616	32*60	M10	140	110	130	5	202.5	61.0
902	32*60	M12	140	130	215	6	202.5	61.0
911	32*60	M12	140	180	215	6	202.5	61.0
932	38*80	M12	160	180	215	6	241.0	99.5

The dimensions e and e1 will change for the coupling type "clamping hub with groove" (KNN). Please contact us for consultation!

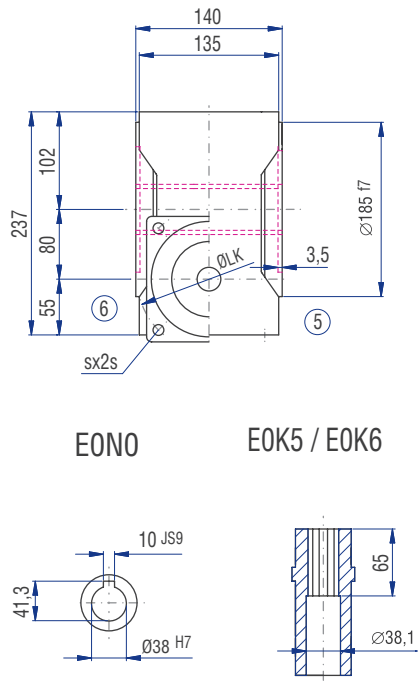
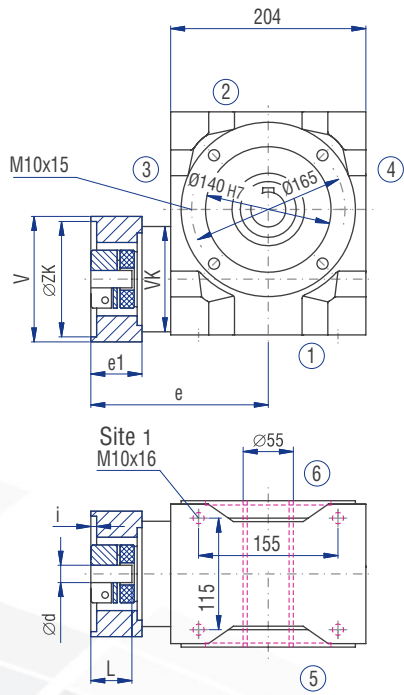

EON0

EOK5 / EOK6

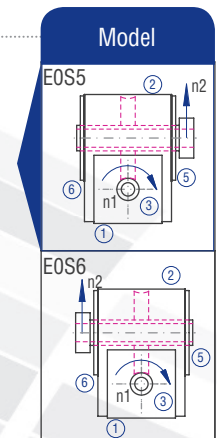
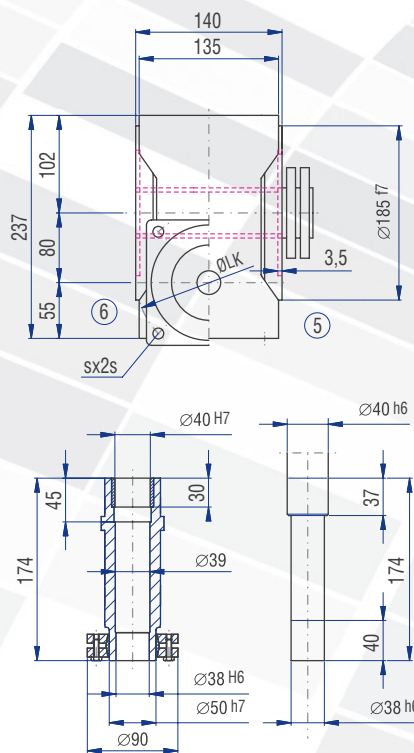
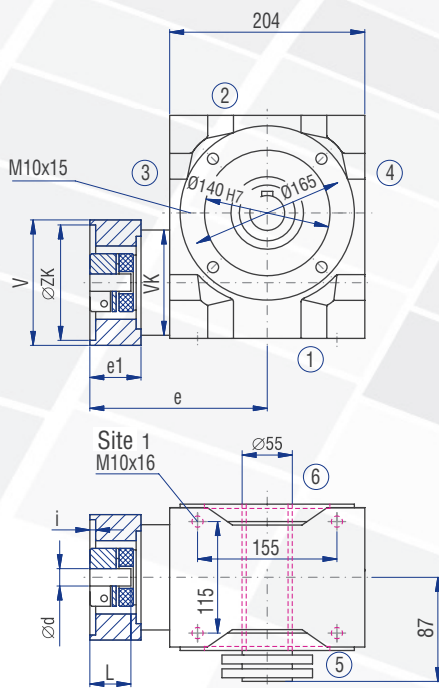
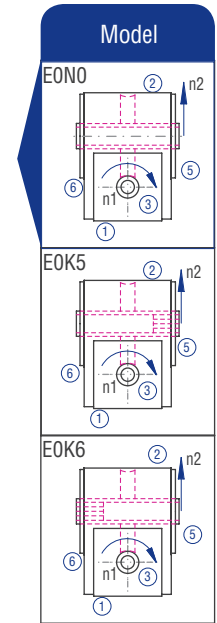
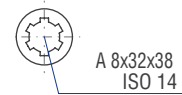

Servo gearboxes  
(precision gearboxes)



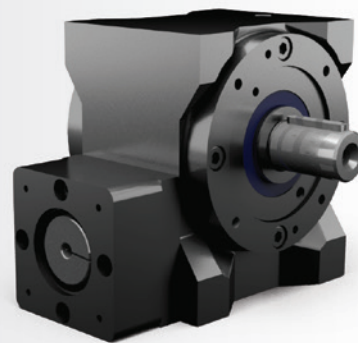

## Characteristics

Characteristic	Standard	Option
<b>Toothing</b>	Hardened and ground worm shaft / bronze worm gear	See chapter 11.5.2
<b>Gear ratio</b>	10:1 to 20:1	
<b>Housing / Flanges</b>	Grey cast iron / aluminium	
<b>Threaded mounting holes</b>	On gearbox side 1 and on the flanges	See chapter 11.5.4
<b>Shaft</b>	Material 1 C45, shaft ends greased Fit with ISO j6 tolerance with parallel keyway: according to DIN 6885 Sheet 1	See chapter 4.6.2
<b>Hollow shaft</b>	Material 1 C45, shafts greased Fit with ISO H7 tolerance with parallel keyway: according to DIN 6885 Sheet 1	See chapter 4.6.3
<b>Radial shaft seal ring</b>	NBR, form A	See chapter 4.8
<b>Ambient temperature</b>	-10°C to +90°C. The values of the performance tables are valid for +20°C	See chapter 4.9.3
<b>Circumferential backlash</b>	< 20 arcmin	See chapter 11.5.11
<b>Protection class</b>	IP 54	See chapter 4.5
<b>Corrosion protection</b>	Prime coat; layer thickness > 40 µm	See chapter 4.4.1
<b>Bearing life L10h</b>	more than 15,000h	See chapter 4.9.1
<b>Oil change intervals</b>	Not required if the oil temperature is kept < 90°C The lifetime of the bearings can be increased by the factor 1.5 if the oil is changed after the first 500 service hours and then every 5000 service hours.	See chapter 11.5.9
<b>Lubricants</b>	Synthetic lubricants	See chapter 11.5.9
<b>Motor flange</b>	Aluminium	See chapter 11.5.14
<b>Coupling</b>	Insertable, flexible claw coupling, suitable for servo-motors For smooth motor shafts      clamping hub      KN For smooth motor shafts      tension ring hub      SN For motor shafts with parallel key clamping hub with groove      KNN	See chapter 11.5.13

## Torques in operating mode S1

I rated I ist	10:1		20:1	
	$n_2$ [1/min]	$T_{2N}$ [Nm]	$n_2$ [1/min]	$T_{2N}$ [Nm]
4000	400	132	200	153
3000	300	177	150	203
2400	240	222	120	253
1500	150	267	75	303

## Torques in operating mode S5

Coupling size	d [mm]	I rated $T_{2N}$ [Nm] $n_{1max}$ [U/min]	10:1		20:1	
			KN	KNN/SN	KN	KNN/SN
K24	11	$T_{2B}$ [Nm]	350,0	408,0	498,0	498,0
		$T_{2NOT}$ [Nm]	450,0	0,0	725,0	0,0
	14	$T_{2B}$ [Nm]	360,0	408,0	498,0	498,0
		$T_{2NOT}$ [Nm]	450,0	625,0	725,0	725,0
	16	$T_{2B}$ [Nm]	390,0	408,0	498,0	498,0
		$T_{2NOT}$ [Nm]	500,0	625,0	725,0	725,0
	19	$T_{2B}$ [Nm]	390,0	408,0	498,0	498,0
		$T_{2NOT}$ [Nm]	600,0	625,0	725,0	725,0
	24	$T_{2B}$ [Nm]	408,0	408,0	498,0	498,0
		$T_{2NOT}$ [Nm]	625,0	625,0	725,0	725,0
	28	$T_{2B}$ [Nm]	408,0	408,0	498,0	498,0
		$T_{2NOT}$ [Nm]	625,0	625,0	725,0	725,0
K28	14	$T_{2B}$ [Nm]	408,0		498,0	
		$T_{2NOT}$ [Nm]	625,0		725,0	
	16	$T_{2B}$ [Nm]	408,0	408,0	498,0	498,0
		$T_{2NOT}$ [Nm]	625,0	625,0	725,0	725,0
	19	$T_{2B}$ [Nm]	408,0	408,0	498,0	498,0
		$T_{2NOT}$ [Nm]	625,0	625,0	725,0	725,0
	24	$T_{2B}$ [Nm]	408,0	408,0	498,0	498,0
		$T_{2NOT}$ [Nm]	625,0	625,0	725,0	725,0
	28	$T_{2B}$ [Nm]	408,0	408,0	498,0	498,0
		$T_{2NOT}$ [Nm]	625,0	625,0	725,0	725,0
	32	$T_{2B}$ [Nm]	408,0	408,0	498,0	498,0
		$T_{2NOT}$ [Nm]	625,0	625,0	725,0	725,0
38	$T_{2B}$ [Nm]	408,0	408,0	498,0	498,0	
	$T_{2NOT}$ [Nm]	625,0	0,0	725,0	0,0	

Servo gearboxes  
(precision gearboxes)

## Permissible radial force $F_{r2}$ and axial force $F_{a2}$ on shaft $N_2$

$n_2$ [rpm]	200		125		75		50		30		10	
$T_2$ [Nm]	$F_r$ [N]	$F_a$ [N]	$F_r$ [N]	$F_a$ [N]	$F_r$ [N]	$F_a$ [N]	$F_r$ [N]	$F_a$ [N]	$F_r$ [N]	$F_a$ [N]	$F_r$ [N]	$F_a$ [N]
< 800	3650	1825	4000	2000	4750	2375	5600	2800	6700	3350	9500	4750
> 800	2920	1460	3200	1600	3800	1900	4480	2240	5360	2680	7600	3800

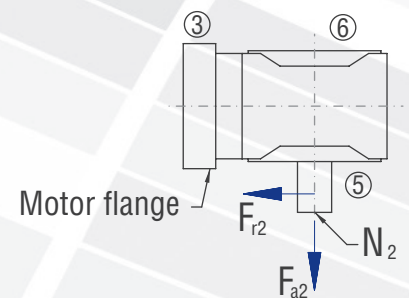

Motor flange

## Gearbox inertia moments/mass

Inertia moment  $J_1$  related to the fast-rotating shaft ( $N_1$ )

i rated [-]	Inertia moment [kgcm <sup>2</sup> ]						
	5:1	7.5:1	10:1	13:1	15:1	20:1	26:1
$J$ [kgcm <sup>2</sup> ]	22.3780	17.8750	14.0300	12.2840	15.1730	12.3740	11.3360

Mass ca. [kg]
53

## Inertia moments Coupling J

K38	KN	KNN	SN
	J [kgcm <sup>2</sup> ]	J [kgcm <sup>2</sup> ]	J [kgcm <sup>2</sup> ]
	4.1710	4.1710	6.4250
	8.4580	8.4580	19.6460

The mass of the gearbox may deviate depending on the flange size and the gear ratio.

# 11.5.20 Type SC 100 – Servo worm gearboxes

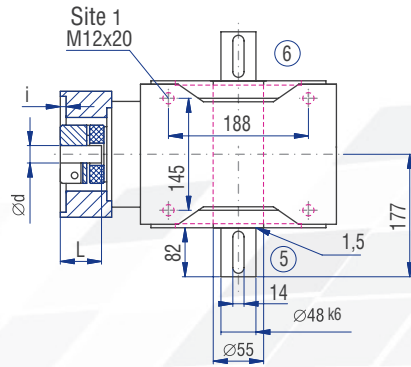
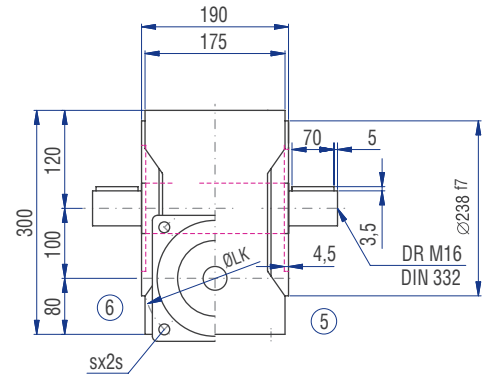
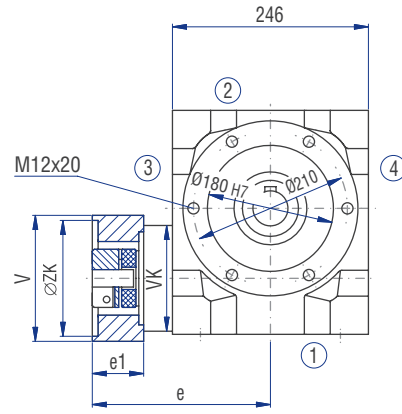
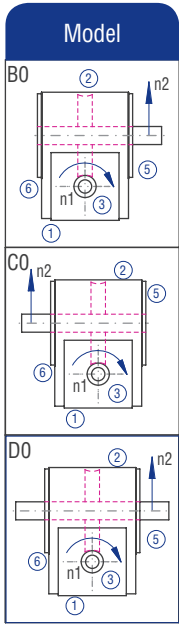

## Implementation VV

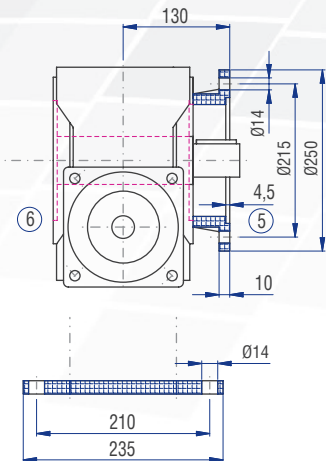
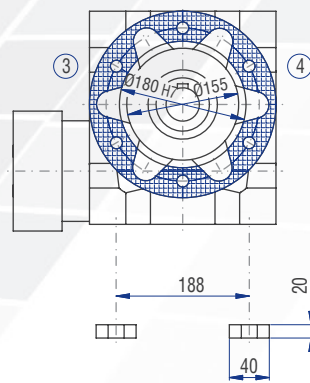
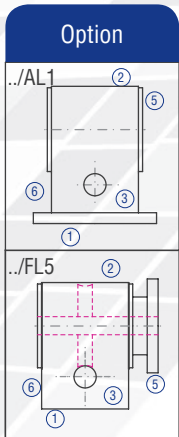
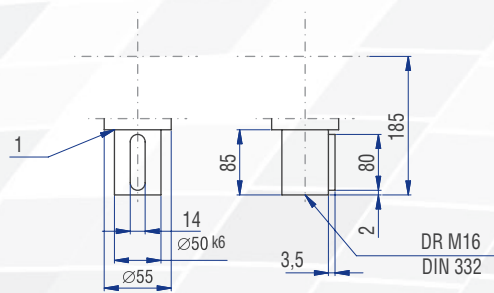

## Motor dimensions

Flange no.	Motor shaft (dxL)	Thread (s)	V [mm]	ZK [mm]	LK [mm]	i [mm]	e [mm]	e1 [mm]
601	32*60	M8	160	95	130	4	242.0	62.0
611	32*60	M8	160	110	130	5	242.0	62.0
701	32*60	M8	160	110	145	5	242.0	62.0
802	32*60	M10	160	110	165	5	242.0	62.0
811	32*60	M10	160	130	165	5	242.0	62.0
403	32*60	M6	160	80	100	4	242.0	62.0
502	32*60	M8	160	95	115	4	242.0	62.0
616	32*60	M10	160	110	130	5	242.0	62.0
902	32*60	M12	160	130	215	6	242.0	62.0
911	32*60	M12	160	180	215	6	242.0	62.0

The dimensions e and e1 will change for the coupling type "clamping hub with groove" (KNN). Please contact us for consultation!

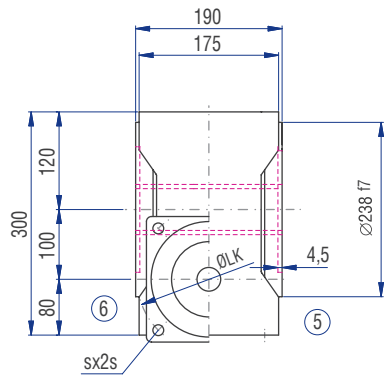
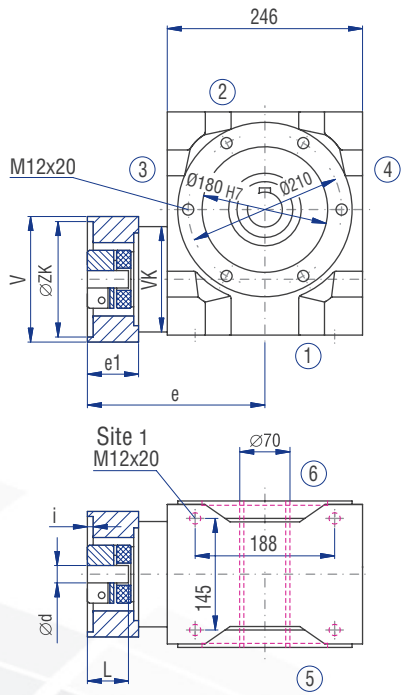

EON0

EOK5 / EOK6

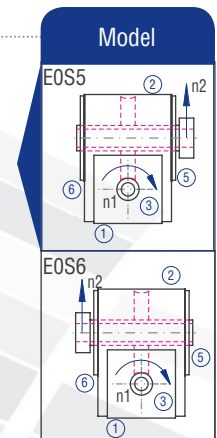
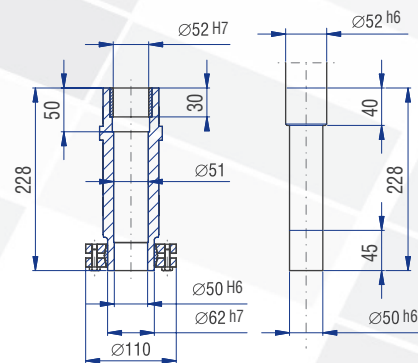
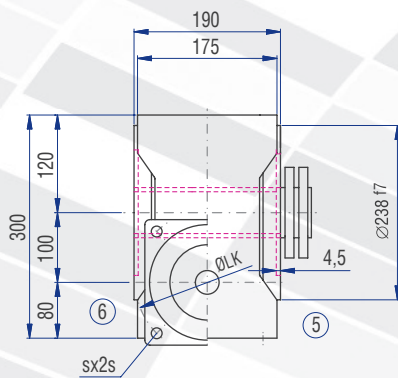
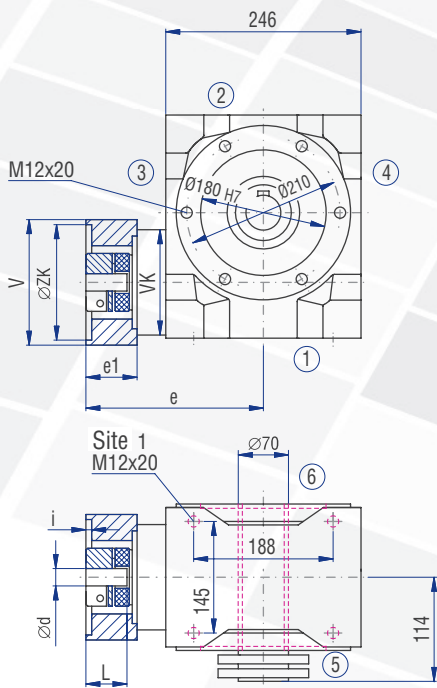
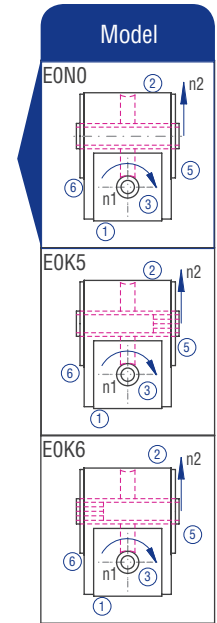
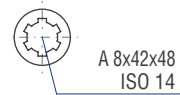
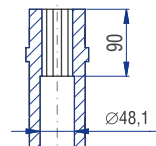
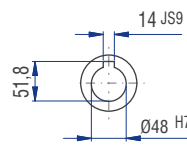

Servo gearboxes  
(precision gearboxes)